

See discussions, stats, and author profiles for this publication at: <https://www.researchgate.net/publication/291587351>

Green Agro-Industry investment for our future

Conference Paper · November 2013

CITATIONS

0

READS

5,824

1 author:



[Onofre S. Corpuz](#)

Cotabato Foundation College of Science and Technology

29 PUBLICATIONS 47 CITATIONS

SEE PROFILE

Some of the authors of this publication are also working on these related projects:



climate change mitigation [View project](#)



**Green Agro - Industry
Investment For Our Future**
International Conference, Yogyakarta, Indonesia, November 12-14, 2013

Organized by:
**Faculty of Agriculture,
Universitas Pembangunan Nasional "Veteran" Yogyakarta**

and supported by:



Proceedings

**International Conference on Green Agro-Industry
(ICGAI)**

Scientific Editors

**Jesusa D. Ortuoste
Sulaiman Hanapi
Endang Gumbira Sa'id
Wimalaratana
Setyo Wardoyo
Ratna Roostika
Partoyo
Mofit Eko Poerwanto
Rukmowati Brotodjojo**

Technical Editors

**Oktavia S. Padmini
Yanisworo W.R
Indah Widowati
R. Agus Widodo**

Chairperson

Sri Wuryani

**FACULTY OF AGRICULTURE
UNIVERSITAS PEMBANGUNAN NASIONAL “VETERAN”
YOGYAKARTA**

2013 ICGAI Committee

Steering & Scientific committee

1. Prof. Sakae Shibusawa – Tokyo University of Agriculture and Technology, Japan
2. Prof. Dr. Nilda Burgos – University of Arkansas, USA
3. Prof. Dr. Lin Qing – Fujian Normal University, China
4. Prof. Paul Holford – University of Western Sydney, Australia
5. Prof. Sri Rahardjo – Universitas Gadjah Mada, Indonesia
6. Prof. Suharto – Universitas Pembangunan Nasional “Veteran” Yogyakarta, Indonesia
7. Prof. Jesusa D. Ortuoste – Sultan Kudarat State University, Philippines
8. Prof. Sulaiman Hanapi – Universitas Malaysia Sarawak, Malaysia
9. Prof. Endang Gumbira Sa'id – Bogor Agricultural University, Indonesia
10. Dr. Wimalaratana - University of Colombo, Sri Lanka
11. Dr. Coen van Ruiten – HAS den Bosch, Netherlands
12. Dr. Rosa S. Rolle – Agricultural and Food Engineering Technologies Service, FAO Agricultural Support Systems Division, Thailand)
13. Dr. Siti Syamsiar – Universitas Pembangunan Nasional “Veteran” Yogyakarta, Indonesia
14. Dr. Setyo Wardoyo – Universitas Pembangunan Nasional “Veteran” Yogyakarta, Indonesia
15. Ratna Roostika, PhD – Universitas Pembangunan Nasional “Veteran” Yogyakarta, Indonesia
16. Partoyo, PhD – Universitas Pembangunan Nasional “Veteran” Yogyakarta, Indonesia

Organizing Committee Members

Chair person	:	Assoc. Prof. Dr. Sri Wuryani
Vice chair person	:	Dr. Rr. Rukmowati Brotodjojo
Secretary	:	Dr. Mofit Eko Poerwanto, Sari Virgawati, Tuti Setyaningrum
Treasure	:	Dyah Arbiwati, Dwi Aulia Puspitaningrum
Proceeding and Paper	:	Dr. Oktavia Sarhesti Padmini, Dr. Yanisworo WR, Indah Widowati, R. Agus Widodo
Program Section	:	Ari Wijayani, Heni Handri Utami, Vini Arumsari, Dr. Budyastuti
Presentation	:	Ellen Rosyelina Sasmita, Dr. Budiarto, Didi Saidi
Food and Beverage	:	Wulandari D.E.R, Heti Herastuti,
Sponsorship	:	Dr. Mustajab Hery Kusnadi, Vandrias Dewantoro
Accommodation and Publication	:	Darban Haryanto, Lanjar Sudarto, Tutut Wirawati, Agus Santosa, Endah Budi Irawati, Endah Wahyurini,

Preface

Over the past decades, rapid growth of global economic has lifted millions of people out of poverty. In line with rising population, rapid urbanization, and industrialization, it has also led to increase consumption of resources and generate of waste almost beyond the limits of the ecological carrying capacity.

The coming decades will likely witness of the increasing pressures on industries to shift to more resource-efficient and low-carbon production processes as part of global efforts to sustain growth, conserve resources and slow down the pace of climate change. Countries and regions that successfully manage this transition will get a better position to exploit the opportunities created by the shift towards a low-carbon world economy. It is green industry's initiation, a pattern of industrial development that is sustainable in economic, environment and social.

Universitas Pembangunan Nasional "Veteran" Yogyakarta in conjunction with its global partners is proud to announce the International Conference on Green Agro-Industry, to be held on November 11-14, 2013, at Yogyakarta, Indonesia. The basic aim of the conference is to contribute to the development of highly productive methods and technologies for the various segments of the agro-industries. This conference is designed to provide a forum for the presentation, discussion and debate on state-of-the-art and emerging technologies in the field of agro based industry and any issues related to sustain the environment.

Finally, we would like to express our gratitude to the Rector UPN "Veteran", Yogyakarta for the financial support, the Dean of the Faculty of Agriculture for hosting, and the Scientific and Steering Committee. We wish to thank the keynote speaker Director of PT Astra Agro Lestari Tbk and Plenary Speakers: Prof. Sakae Shibusawa (Tokyo University of Agriculture and Technology, Japan), Prof. Raj. Khosla, Ph.D. (Colorado State University, USA), Prof. Dr. Nilda Burgos (University of Arkansas, USA) Ir. Toine Hattink (Director of Department of Horticulture, HAS den Bosch, Netherlands) Prof. Dr. Endang Gumbira Sa'id (Bogor Agricultural University, Indonesia) . Nur Iswanto, PhD. (IKAGI, International Society of Sugar Cane Technologists Councillor), Prof. Wijitapure Wimalaratana. (Department of Economics, University of Colombo), Prof. Hassan M. El Shaer (Desert Research Center, Cairo, Egypt), Dr. Mofit Eko Poerwanto (UPN "Veteran" Yogyakarta, Indonesia) as well as participants for their contribution in making the International Conference on Green Agro-Industry.

We wish to thank PT Astra Agro lestari as the major sponsor and all other sponsors for their contribution in making this Conference possible. As a Chairperson, I highly appreciate the great efforts of the members of the organizing committee whose hard work made this seminar a great success.

Yogyakarta, November 11 , 2013

Sri Wuryani

Chairperson, ICGAI 2013

Contents

Table of Contents

Committees
Preface

Keynote Speaker

Managing Green Agro-Industry: Economic, Environmental and Social Consideration. PT Astra Agro Lestari Tbk (**Joko Supriyono**) **K - 1**

Plenary Speakers:

- 1 Eco-friendly agrochemicals practices to support green agro-industry. **Nilda Burgos**. University of Arkansas, USA. **P-1**
- 2 Sustainable Horticulture Supply Chains. **Toine Hattink**. Director of Department of Horticulture, HAS den Bosch, Netherlands. **P-10**
- 3 Zero waste technology in green agro-industry: Special Case for Palm Oil Industrial Cluster. **Endang Gumbira Sa'id** (Bogor Agricultural University, Indonesia) **P-17**
- 4 Integrated Sugar Industry: Maximizing Energy Utilization of the Cane. **Nur Iswanto**. IKAGI, International Society of Sugar Cane Technologists Councillor. **P-30**
- 5 Economic Perspective Of Sustainable Agro Industry. **Wijitapure Wimalaratana**. Department of Economics, University of Colombo **P-39**
- 6 Implementation of precision farming in green agro-industry concept. **Sakae Shibusawa**. Department of Environmental and Agricultural Engineering, Tokyo University of Agriculture and Technology, Fuchu, Japan **P - 45**
- 7 New approaches in Management and Utilization of Agriculture Wastes in the WANA Region. (**Hassan M. El Shaer**) (Desert Research Center, Cairo, Egypt) **P-53**
- 8 Implementation of green agriculture technology for reducing CVPD. **Mofit Eko Poerwanto**. UPN "Veteran" Yogyakarta, Indonesia) **P-65**

Economic and Business

- 1 Micro, Small and Medium-Sized Enterprises of Banana's Variety Products to Support the Green Agro-Industry. (**Heni Handri Utami, Siti Hamidah**) 1
- 2 Impact of Plant Conservation on Additional Income Generation in Rural Gardens: A Case Study of Talawi Mudik Village of West Sumatera. (**Sumilah, Nirmala F. Devy and Hayani**) 8
- 3 The Role of Women in Developing Entrepreneur / Merchandise Case in Maju Makmur Small Group Activity (Sga) Kejajar District, Wonosobo Regency, Central of Java. (**Teguh Kismantoroadji and Indah Widowati**) 16
- 4 Analysis Effect Of Environmental Food Production Toward Consumer's Intermediate Behaviour Product Slice Noodle. (**Novita Erma K.**) 21

Agronomy

- 1 Application of Agricultural Waste to Reduce Inorganic Fertilizer and Improve Sugarcane Plant Resistance to Stem Borer Attack. (**R.R. Rukmowati Brotodjojo, Oktavia S Padmini, Saefudin Saeroji**) 31
- 2 Climatic Factor in Epidemic of Vascular Streak Dieback of Cocoa (**Herry Wirianata, Suprih Wijayani, Elisabeth Nanik K**) 40
- 3 The Effectiveness of Several Dosages of Sour-Sop (*Annona Muricata* L.) Leaves and Seeds Powder for Controlling *Callosobruchus Sp.* and Maintaining the Quality of Mungbean Stored Seeds. (**Ami Suryawati , Chimayatus Solichah**) 45
- 4 Field application of Oberon[®] and Envidor[®] on *oligonychus sacchari* (prostigmata: tetranychidae) and its predator *stethorus punctillum* (Coleoptera: Coccinellidae). (**Amin Nikpay, Masoud Arbabi, Peyman Sharafizadeh, Mahmood Poormahmood**) 54
- 5 Implementation of Mineral Oil for Controlling Aphid and White Rust Disease of Chrysanthemum. (**Mofit Eko Poerwanto & Ari Wijayani**) 60
- 6 The Role of Weeds in the Spread of Vector of Peanut Stripe Virus (PSTV). (**Mofit Eko Poerwanto, Siwi Hardiastuti EK**) 66
- 7 In Vitro and *In Vivo* Digestibility Evaluation of *Bacillus* Phytases in Plant Ingredients and Diets by Tilapia, *Oreochromis Mossambicus* (**Rande B. Dechavez , Augusto E. Serrano Jr.**) 72

8	Isolation and Expression Analysis of Hydroxy Phenyl Pyruvate Reductase (HPPR) Derived from <i>Orthosiphon aristatus</i> (Hairul Azman Roslan, Zuliza Ahmad) ⁸⁷	89
9	Evaluation of the Effect of <i>Azospirillum</i> -like Bacteria on the Growth and Yield of Green Onion (<i>Allium cepa</i> L.). (Carlos E. Lacamento)	96
10	Characterization and Evaluation of Microflora Bacteria on Various Plantation Soils Against <i>Phytophthora Capsici</i> of Black Pepper (<i>Piper Nigrum</i> L.), (Awang Ahmad Sallehin Awang Husaini, Linda Nirwana Caroline, Samuel Lihan, Hairul Azman Roslan, Mohd Hasnain Md Hussain)	106
11	Heterologous Expression of Xylanase Gene from <i>Klebsiella Pneumoniae</i> in <i>E. Coli</i> B121 (De3) for Potential Use in Green Technology. (Suhaila Zainol, Nikson Fatt Ming Chong, Awang Ahmad Sallehin Awang Husaini)	113
12	Genetic Diversity of Fusarium Wilt Resistant Potato Planlet Produced by Gamma Ray Irradiation. (Rahayu Sulistianingsih, Rina Sri Lestari and Ari Wijayani)	118
13	Nutrient Analysis of Palm Empty Fruit Bunch, Palm Fruit Fibers and Sawdust as Media for White Oyster Mushroom Cultivation. (Sulistiyanto. Y , Balfast. Usup. A)	125
14	Growth and Yield of Sweet Potato Varieties Using Organic and Inorganic Fertilizers and Vermitea. (Ana Maria F. Maglalang , Tessie E Navarro)	135
15	Use of Poultry Manure as Carrier for Biofertilizers: Effects on Maize (<i>Zea Mays</i>) Growth. (Tunde Ezekiel Lawal, Olubukola Oluranti Babalola)	147
16	The Effect of Various Fertilizers on the Growth of Oil Palm Seedlings in The Main Nursery. (Pauliz Budi Hastuti , Ni Made Titiaryanti)	154
17	Gibberellic Acid Synthesis in the Developing Seeds of Cocoa (Yohana Theresia Maria Astuti, Kumala Dewi, Santosa, A. Adi Prawoto)	161
18	Alternative Propagation Technology for Rubber (<i>Hevea Brasiliensis</i>). (Onofre S. Corpuz)	169
19	Testing and Evaluation of Upland Rice Varieties in Sultan Kudarat Province (R. Ortuoste , J. Ortuoste)	182
20	Improvement of Wheat (<i>Triticum Aestivum</i> L.) Crop Tolerant in Lowland through Mutation Induction. (Budyastuti Pringgohandoko)	193
21	Utilization of Waste Palm Oil as a Source Soil Organic Matter for Support Green Agroindustry. (S. Setyo Wardoyo)	202

22	Improving Soil Productivity with Biochars (Arnoldus Klau Berek, Nguyen V. Hue)	209
23	Land Management Salak Pondoh (<i>Salacca Edulis Reinw</i>) Especially Based on Altitude at Turi Sleman. (Subroto Padmosudarso)	220
24	Development of Purwaceng (<i>Pimpinella pruatjan</i> Molkenb) to Support Herbs Industry and Soil Conservation in Dieng Plateau, Central Java. (Partoyo, Eko Amiadji Julianto, M. Husain Kasim, Teguh Kismantoroadji, and Indah Widowati)	226
25	Isolation and Characterization of Humic Acid of Various Waste Matterial on Saline Soil and Their Effects to Paddy. (Wanti Mindari, W. Guntoro, Zaenal Kusuma, Syekhfani)	234

Clean Technology

1	LCA Methods on The Treatment of Biomass Residues In a Palm-Oil System. (Edi Iswanto Wiloso, Reinout Heijungs)	243
2	Reducing Ammonia Gas Concentration from Composting of Leftover Food by Natural Zeolite from Japan (Ida Ayu Gede Bintang Madrini, Sakae Shibusawa, Yoichiro Kojima, Shun Hosaka)	254
3	A Study of Soil Adsorption Toward Chromium in Liquid Waste from Tanning Industry (Agung Sahida, Sari Virgawati, AZ. Purwono)	260

Agriculture Engineering

1	Growth and Leaves Digital Image Analysis of Rice Cultivated in Various Levels of Nitrogen Concentration and Brown Planthopper Infestation. (Partoyo, Mofit Eko Purwanto, Sari Virgawati, Frans Richard Kodong, Sri Sumarsih)	270
2	Productivity, Soil Fertility, and Economic Benefit in Changes from Conventional to Organic Rice Farming System at Sragen District. (Oktavia Sarhesti Padmini),	280
3	Utilization of visible-Near Infrared Real-Time Soil Sensor as a Practical Tool for Precision Carbon Farming Practice. (B. S. N. Aliah, S. Shibusawa, M. Kodaira)	288
4	Designing of Ergonomic Soybean Grinder to Increase Industry Productivity (Case Study on Home Industry of “Tempe” In Bantul, Yogyakarta). (Dyah Rachmawati Lucitasari and Deny)	297

- | | | |
|---|---|-----|
| 5 | Organic Farming Technology Using Guano Fertilizer and Mulch in Cultivating String Beans (<i>Phaseolus vulgaris</i> L.)
(Tutut Wirawati and Endah Budi Irawati) | 303 |
|---|---|-----|

Other Topic

- | | | |
|---|---|-----|
| 1 | Study of Growth Hormone Gene Variety Based on Bioinformatics.
(Mariana Rengkuan) | 308 |
| 2 | SWOT Analisis for Integrated Eco-Tourism Development in Strengthening National Resilience (Case Study in Gajah Wong River, Yogyakarta, Indonesia). (Istiana Rahatmawati) | 318 |
| 3 | People Empowerment throught Green Water Resources (Study in Gajah Wong River) (Purbudi Wahyuni) | 327 |

Poster

- | | | |
|----|--|-----|
| 1. | Prospect of Clove Leaf Based Essential Oil Industry in Indonesia: A Case Study of District Samigaluh Kulonprogo Regency (Juarini, Ni Made Suyastiri YP) | 335 |
| 2 | The Analysis of Technological Contribution and Competitiveness of Cokrotela Cake Company Yogyakarta to Support Green Agroindustry. (Sri Wuryani, Budiarto, Ani M. Nurhayati) | 344 |
| 3 | Effect of Varieties and Blanching for Making Cocoyam (<i>Xanthosoma</i> Sp) Flour and Food Product. (S.S. Antarlina , P.E.R. Prahardini, S.S. Antarlina , P.E.R. Prahardini) | 351 |
| 4 | Diversified Food Products of Pumpkin (<i>Cucurbita moschata</i>). (Aniswatul Khamidah , SS. Antarlina) | 359 |
| 5 | Fresh Calyses as Health Drink from Roselle Cultivation in Polybags Utilizing Open Spaces at Home. (Sugeng Priyanto and Wahyu Widodo) | 371 |
| 6 | Growth Performance and Potential Oil Content of Several Basil (<i>Ocimum Basilicum</i> Linn) Variety as Fruit Fly Controller (S. Yuniastuti, L Rosmahani, E Korlina, W. Handayati) | 375 |
| 7 | Survival of Sugarcane White Grub in Treated Soil by Entomopathogenic Fungi (Harjaka T, B.H. Sunarminto, E. Martono) | 381 |
| 8 | Application of Nano Particles in Pest Management Programs - A Review. (Masumeh Ziaee, Fatemeh Hamzavi) | 386 |

9	A Review of Plant Essential Oils as a Component of Integrated Pest Management in Stored Products Protection. (Masumeh Ziaee, Fatemeh Hamzavi)	394
10	Screening of Sweet Potato Genotypes for Water Stress Resistance. (Agnes C. Perey, Belinda A. Tad-awan)	403
11	Yield Potency of Sweet Potato Varieties under Drought Condition in Sandy Land. (Tutut Wirawati, Endah Budi Irawati, Ami Suryawati)	418
12	The Identification of Useful Vegetations on Different Ages of Oil Palm (<i>Elaeis quineensis</i> Jack). (Ety Rosa Setyawati)	424
13	Variation on Colchicine'S Concentrations and Germination Phases to Produce Polyploid Tomato Plant. (Rati Riyati, Nurngaini, Basuki)	433
14	Utilization of Critical Land for Tuber Crops Cultivation as Raw Materials of Agro-Industry (Bargumono, Tuti Setyaningrum)	440
15	Potential of Thermotolerance Isolates Bacteria from the Land that Affected by Merapi Eruption as a Plant Growth Promoting Rhizobacteria (PGPR). (Yanisworo W Ratih, Lelanti P Wiratri)	443
16	The Application of PGPR (<i>Plant Growth Promoting rhizobacteria</i>) on Chili Plant as an Interposed Plant between Salak Plant in Sub-District Srumbung (Ellen R. Sasmita, Sri Sumarsih, Oktavia S. Padmini and Endah B. Irawati)	451
17	A Study of Impact of Brick Industries on Soil Fertility in Potorono Banguntapan Bantul Yogyakarta (R. Agus Widodo, Susila Herlambang)	462
18.	The Potential of Groundwater on Unconfined Aquifer in Jogonalan Area Klaten Central Java. (Lanjar Sudarto)	469
19.	Determination of Depth Groundwater Levels Based on Geophysical with Geoelectric Method Around the Prambanan Temple Region Yogyakarta Province. (Agus Santoso, Sismanto, Ari Setiawan, Subagyo)	475

MANAGING GREEN AGRO-INDUSTRY: ECONOMIC, ENVIRONMENTAL AND SOCIAL CONSIDERATION

Joko Supriyono

General Secretary of Indonesian Palm Oil Association

Email Bandung 27@yahoo.com

ABSTRACT

Increasing global awareness toward the importance of sustainability has triggered green initiation in various sectors including agro-industries. For many years, agriculture has played a role as the world's machine of food production. Intensification and extensification to produce more food may bring environmental consequences. Green initiation for food production which consider economic, environmental, and social aspect is the key to ensure the long lasting food security. Palm oil is the most importance vegetable oil in the world where Indonesia and Malaysia are the biggest producers. Green initiation in palm oil industry is an excellent example to learn and evaluate how the scheme of green industry can be implemented. Indonesia Sustainable Palm Oil (ISPO) scheme is a green initiation launched by the Government of Indonesia to ensure that the production of palm oil is resulted from low-carbon, resource-efficient and zero-waste processes. Our data has far showed that implementation of best management practices under ISPO scheme can maintain high extent of biodiversity, low-carbon cost, and brings benefits for local community. Application of zero-waste policy has resulted in more carbon saving compared with BAU (business as usual). During the process, palm cultivation does not only emit carbon instead of absorbs more carbon from the atmosphere. Establishment of oil palm plantation has created jobs and increased local income. Implication of these findings toward the establishment of green palm oil industry are discussed.

Keywords: Palm oil, ISPO, biodiversity, emission, community

INTRODUCTION

Rapid growth of world's population and global economic, which is followed by rapid urbanization and industrialization, have led to increased consumption of resources and generated waste almost beyond the limits of the ecological carrying capacity. Increasing global awareness toward the importance of sustainability has triggered industries to shift to more resource-efficient and low-carbon production processes as part of global efforts to sustain growth, conserve resources and slow down the pace of climate change.

In the recent years, the term of "Green Industry" has been globally discussed by many people from different community, background and country. It is also frequently associated with the term of "sustainable". United Nations Industrial Development Organization (UNIDO) has launched the Green Industry initiative in order to provide

the international community, national governments and the private sector with a platform for fostering the positive role of industry in achieving sustainable development (Unido 2011). The Green Industry vision grasps the potential for industries to decouple economic growth and revenues from excessive and increasing resource use and pollution. It foresees a world where industrial sectors minimize waste in every form, utilize renewable resources as input materials and fuels, and take every possible precaution to avoid harming workers, communities, climate, or the environment. Green industries will be creative and innovative, constantly developing new ways of improving their economic, environmental and social performance.

In the UNIDO's scheme, *Green Industry* promotes sustainable patterns of production and consumption i.e. patterns that are resource and energy efficient, low-carbon and low waste, non-polluting and safe, and which produce products that are responsibly managed throughout their lifecycle. The *Green Industry* agenda covers the greening of industries, under which all industries continuously improve their resource productivity and environmental performance. It also aims to create green industries, that deliver environmental goods and services in an industrial manner, including, for example, waste management and recycling services, renewable energy technologies, and environmental analytical and advisory services. The greening of industries has become a core determinant of economic competitiveness and sustainable growth. Since resource inputs represent an important production cost for industries, improving efficiency gives industries a competitive advantage. The greening of industries also plays a role in poverty alleviation, through promoting energy security, health and safety, jobs, and reducing costs through increased productivity (Unido 2011).

In Indonesia, the term of green industry is mostly associated with industrial products which are friendly to environment. The Government has seriously responded the importance of green products for better environment, economic and social performance. This can be seen from green industry award program launched by The Ministry of Industry in May 2013 as regulated under the Ministerial Decree **05/M-IND/PER/1/2011**. The award is given every year to industry that has a strong contribution to national economic development, local community empowerment and actively involved in maintaining ecosystem sustainability. The ultimate aim of the program is to trigger industrial sector to be more actively involved in promoting green industry.

A. Green Industry in Agricultural Sector: Why Is it important?

Agricultural industries hold a strategic position since they are the key for the fulfillment of human's basic needs. For many years, agriculture have played major role in providing food for more than seven billion world's population. By 2050, world's population is projected to reach 9.3 billion (35% from the current population). Therefore, agricultural sector has to be enhanced to ensure food availability to feed the increasing world's population. In the other hand, some agricultural commodities such as corn, sunflower, soybean, and palm oil are the source of alternative energy to replace fossil fuel. It can be expected that intensification and exploitation of natural resources would be the main activities to meet the target.

Various technologies have been developed to increase the quantity and quality of food. Unfortunately, during the process, many agricultural activities are capable of

threatening the ecosystem. At the same time the health of ecosystem is also the key to ensure long lasting agriculture productivity. Due to this, the sustainability of agriculture becomes a question for many to seek answers of. Concepts and insights were brought in to develop agriculture in a sustainable way. In this paper, we discuss about green industry's initiation in agricultural sector, a pattern of industrial development that is sustainable in economic, environment and social.

B. Managing Green Agro-Industry: Case study from Palm Oil Industry

Green initiation in palm oil industry is an excellent example to learn and evaluate how the scheme of green industry is possible to be implemented. This is true since palm oil plays major role not only for food security, but also as the most important source for bio-energy (bio-fuel). World demand toward palm oil is highest compared with other vegetable oils. The palm oil also becomes the most promising vegetable oil for biofuel since the productivity is very high with lower size of land required to produce the same amount oil compared soybean and sunflower oil (see Table 1). Land size for oil palm plantation only covers 5 % from the total land used for vegetable oil production, however it contributes about 25,6 % of total vegetable oil production (See Fig 1 and Fig 2). This makes the palm oil more efficient and cheaper.

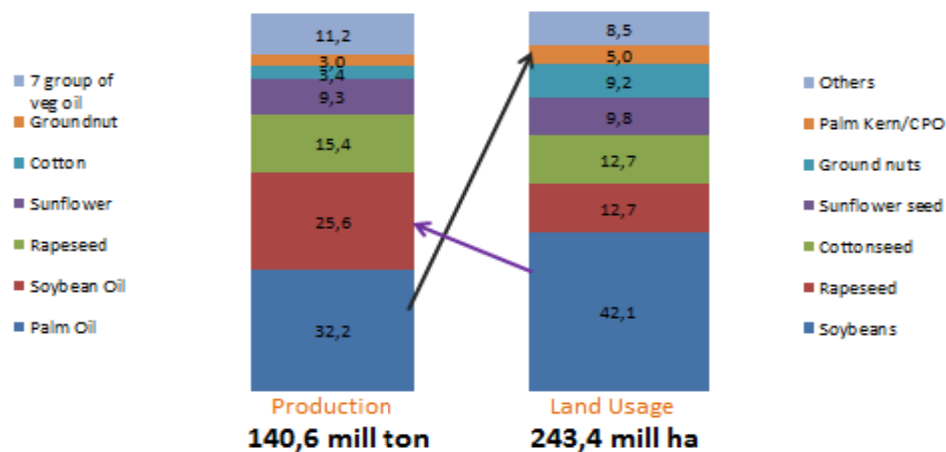

Fig. 1. Production and size of land used for cultivation of several vegetable oils (data extracted from Oilworld 2009).

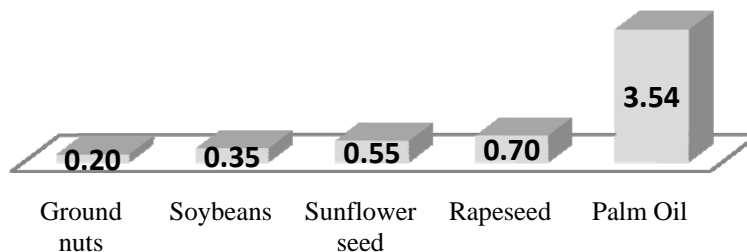

Fig. 2. Oil production of five agricultural commodities (ton/ha/year) (data extracted from oilworld 2009)

Table 1. Life cycle and land size used for cultivation of five agricultural commodities

Crop	Million Ha	Cycle
Ground nuts	20.914	3 months
Soybeans	102.399	3 months
Sunflower seed	23.810	8 months
Rapeseed	59.966	1 year
Palm Oil	12.135	25 years

Among 17 vegetable oils, world consumption of palm oil is the biggest by reaching 59% of world consumed vegetable oils followed by soyabean, sunflower and rapeseed respectively (Fig 2). China, European Union, and India were the three major consumers of palm oil by absorbing 40% world palm oil import (Fig 2). Vegetable oil consumption is expected to significantly increase become 234 million ton in 2020 from 179, 181 million ton in 2011 (see Fig 4). This means that about 55 million ton of vegetable oil should be produced during 9 years to fulfill the need

Since oil palm is only well grown in tropical region, producers mostly coming from tropical countries. Indonesia is the world's top producer of palm oil by contributing 47% of world palm oil supply in 2010, followed by Malaysia which contributed about 37% (see Fig 3). Palm Oil Industry in Indonesia is not only important for economic development, but it is also important for poverty alleviation. It is true since about 22,79% of Indonesian people live under poor threshold. Palm oil industry offers a glimmer of hope for Indonesian people to live better with better livelihood.

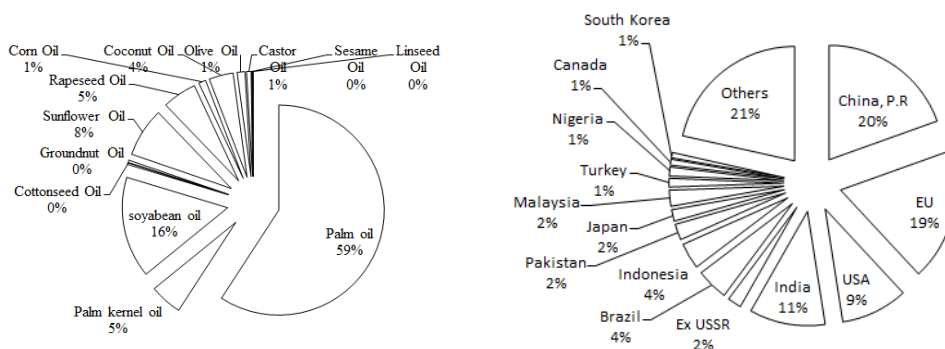

Fig. 2. Proportion of world import of 17 vegetable oils 2010 (left) and palm oil importers (right) (data extracted from Indonesian palm oil statistics 2010).

C. Government Regulations to Support Green Palm Oil Industry

The development of palm oil industries in Indonesia is regulated by Government regulations which mostly support the spirit, concept and phylosophy of Green Industry. This means that The Government has carefully considered the importance of sustainability and the essence of green concept. Below are some examples of how government has placed substantial foundation for oil palm plantation development.

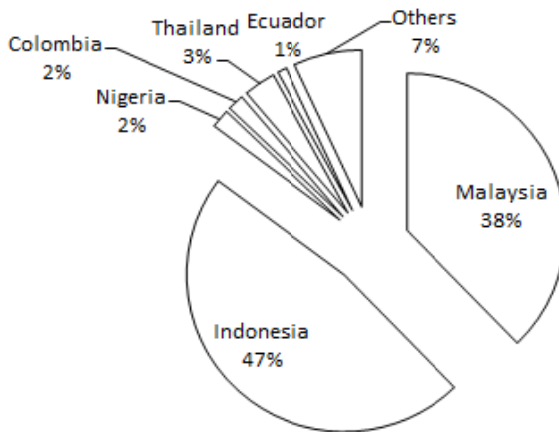

Fig 3. World major producers of palm oil in 2010 (data extracted from Indonesian palm oil statistics 2010)

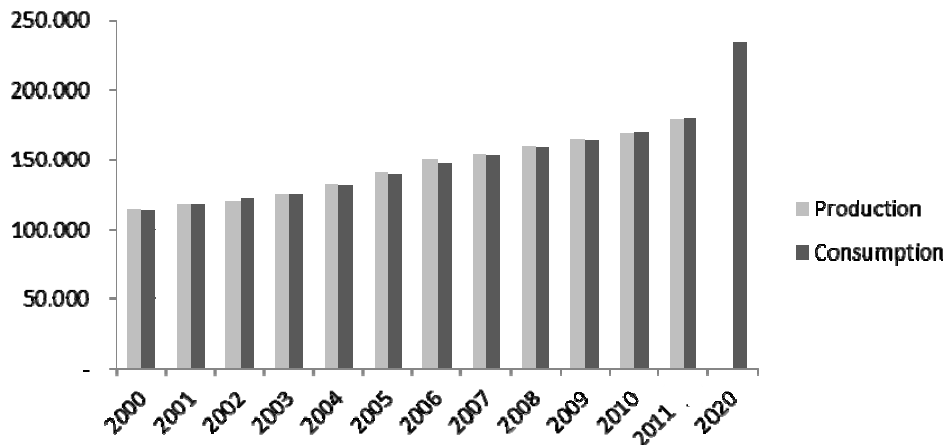

Fig. 4. World 17 Oil and Fats Balance

D. Land Transformation for Oil Palm and Deforestation

In Indonesia, approximately 70% of total land is for forest area and the rest is used for non forest area. Establishment of oil palm plantation could only be happened in non forest area (APL) since forest area is only used for forest protection and biodiversity conservation. (See *Undang-Undang Nomor 18 Tahun 2004 tentang Perkebunan; Keputusan Menteri Pertanian Nomor 357/Kpts/HK.350/2002 Tentang Pedoman Perizinan Usaha Perkebunan; Keputusan Menteri Kehutanan dan Perkebunan Nomor 891/kpts-II/1999 tentang Penunjukan Kawasan Hutan dan Perairan; Undang-Undang Nomor 41 Tahun 1999 tentang Kehutanan; Undang-Undang Nomor 26 Tahun 2007 tentang Penataan Ruang; Undang-undang Nomor 5 Tahun 1960 tentang Peraturan Dasar Pokok-Pokok Agraria; PP No 10 Thn 2010 tentang tata cara perubahan peruntukan dan fungsi kawasan hutan; Keputusan Menteri Kehutanan dan Perkebunan No 376/kpts-ii/1998 tentang kriteria penyediaan areal hutan untuk perkebunan budidaya kelapa sawit*

Unfortunately, expansion of oil palm plantation is frequently judged as the main cause of deforestation (Koh & Wilcove 2007; Koh 2008; Yaap *et al.* 2010; Koh *et al.* 2011; Foster *et al.* 2011). Since oil palm plantation in Indonesia only used about 9,2 million ha or approximately less than 5% of total land in Indonesia (see Table 2), this is not possible to judge oil palm development responsible for massive deforestation. Based on landsat image analysis between 1990 and 2010, showed that the establishment of oil palm plantation in Indonesia was mostly from non forested area, and only 3% of forested area transformed into oil palm plantation (Gunarso *et al.* 2012). This fact shows that the development of oil palm plantation is not substantially related to massive deforestation as reported in many publications.

Table 2. Landuse distribution in Indonesia
(data extracted from Ditjend Planology 2011)

Land Use	Ha	%
Conservation Forest	21.780.626,14	11,5
Protected Forest	30.539.822,36	16,1
Limited Production Forest	27.967.604,50	14,7
Production Forest	30.810.790,34	16,2
Convertible Production Forest	17.924.534,81	9,5
Total Forest Area	129.023.378,15	68,0
Area Penggunaan Lain (APL) (non forest area)	60.613.324,85	32,0
Total Land Area	189.636.703,00	
Total Plantation	20.530.404	10,8
Total Oil Palm plantation (2011)	9.230.072	4,87

E. Best Practices in Oil Palm Management Related to Environment Quality

Oil palm plantation has to be managed under the direction of Government regulation. Land clearing has to be conducted with minimum risk to land fire by applying zero burning policy as regulated under PP No 4 Thn 2001 *tentang pengendalian kerusakan dan atau pencemaran lingkungan hidup yang berkaitan dengan kebakaran hutan dan lahan*. Every single company has to develop program related to environment protection and management which cover several steps including planing, utilization, control, maintainance, surveilance, and law enforcement as regulated by *UU No 32 thn 2009 tentang perlindungan dan pengelolaan lingkungan hidup*. In this scheme, liquid waste, air and water pollution resulted during the process would be the main concern and should be carefully managed to minimize environmental impact and maintain better environment quality.

F. Biodiversity Conservation: What the Data Say?

Biodiversity conservation in Indonesia is regulated by law. It can be seen from various government regulations regulating how biodiversity has to be managed and conserved (See *Undang-Undang Nomor 5 Tahun 1990 tentang Konservasi Sumberdaya Alam Hayati dan Ekosistemnya*; *Undang-Undang Nomor 5 Tahun 1994 tentang ratifikasi United Nations Convention on Biological Diversity*; *Undang-undang Nomor 23 tahun 1997*; *Peraturan Pemerintah Nomor 7 Tahun 1999 tentang Perlindungan Jenis Tumbuhan dan Satwa Liar*;).

Unfortunately, establishment of oil palm plantation is frequently related to biodiversity loss (Koh & Wilcove 2007; Koh 2008; Yaap *et. al* 2010; Koh *et al.* 2011; Foster *et al.* 2011). In many studies, oil palm plantations are frequently seen as a single habitat with uniform tree species and shape, which have a much less complex structure (see Yaap *et al.* 2010), but not seen as a landscape which contain various habitat types. In fact, many oil palm concessions in Indonesia, contain patches of natural habitats that could be a home for many endangered species. This is true since remaining natural habitats such as swamp, karst, riparian, mangrove etc are frequently still remain in the concession, and not converted become oil palm plantation. Some forest species may interact with oil palm plantation and vice versa.

A study conducted in oil palm plantation in Central Kalimantan showed that many forest bird species interact with oil palm plantation. This study evaluated the interaction of birds among secondary forest, swamp forest and oil palm plantation. The two-dimensional scaling plot based on Sørensen indices comparing samples of individual point counts from the three different habitat types indicates, that there is a spatial species turnover among three different habitats (see Fig 4). Based on this MDS (multidimensional scalling), it can be seen that some forest species interact with oil palm plantations, and some of which remain in the natural habitats.

In that case, oil palm companies could play an active role in promoting environmentally friendly oil palm management. In fact many oil palm plantations have successfully developed conservation program that is capable of maintaining high extent of biodiversity under their concession (See Table 3). A study conducted in oil palm landscape in East Kalimantan identified that there are six hornbill species inhabiting the oil palm landscape from eight hornbill species that have ever been reported to exist in Kalimantan (see Table 4). ***This study has shown that implementation of sustainable management has successfully maintained ecosystem quality.***

Table 3. Biodiversity profile from five oil palm plantations

Concession	Location	Conservation area (ha)	Biodiversity Profile		
			Tree Species	Mamals	Bird
Concession A	Central Kalimantan	699,9	123	15	190
Concession B	East Kalimantan	1406	117	29	120
Concession C	East Kalimantan	2017	154	44	128
Concession D	Riau	62,66	73	7	56
Concession E	West Sulawesi	258	108	4	63

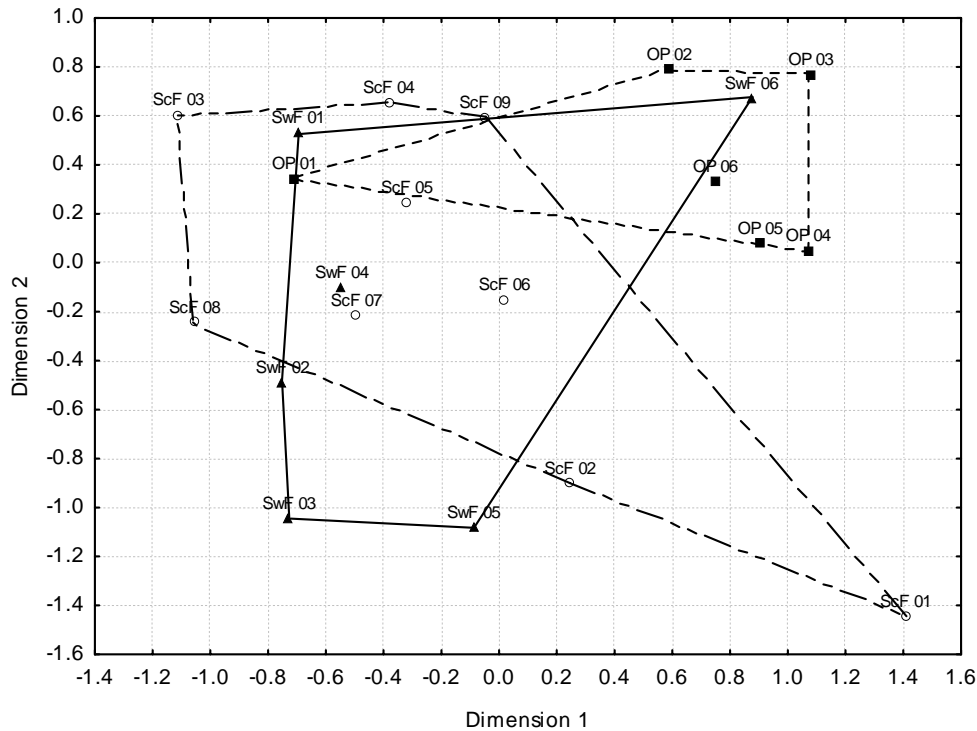

Fig 4. Two-dimensional scaling plot based on Soerensen indices for measuring similarity of species composition between single sampling sites. Connecting lines indicates defined groups of habitats. (Secondary Forest = ScF 01-09; Secondary Swamp Forest = SwF 01-06; Oil Palm Plantation = OP 01-06)

Table 4. Sex ratio and encounter probability of hornbill community inhabiting oil palm landscape in Consession C, East Kalimantan

Species	Observed Plots	Range of Encounter probability	Highest number of individual encountered in one plot	Sex Ratio Female
<i>B. rhinoceros</i>	60	6,7-20 %	21	0,41
<i>A. Albirostris</i>	60	21,67-30 %	15	0,33
<i>A. malayanus</i>	60	20-28,3 %	12	0,39
<i>A. corrugatus</i>	60	8,3-18,3 %	10	0,48
<i>R. vigil</i>	60	5-8,3 %	4	0,42
<i>A. undulatus</i>	60	0-8,3 %	16	0,31

G. Green House Gas (GHG) Emission: Between Rumor and Fact

In many electronic media, palm oil industries are frequently judged as main contributor of carbon emission. However, based on case study from 12 oil palm companies, indicates that carbon emission is lower compared carbon sequestration. The average of carbon emission from 12 plantations was found to be 0,63 ton CO₂/ton cpo-pko product/year or 6,65 ton CO₂/Ha/year. Since palm oil industry is biomass-based

industry, it does not only emit carbon instead of absorbing more carbon from the atmosphere during the process of cultivation in average about 30,28 ton CO₂/Ha/year (unpublished). The source of emission during the production process is coming from three components: (1) fossil fuel combustion, (2) agrochemicals (3) palm oil mill effluent (POME). POME is the highest source of emission by contributing more than 83% carbon emission from palm oil production. GHG mitigation is also supported by Government Regulation as it is expressed in *Presidential Decree No 61 Thn 2011, National Action Planning on Green House Gass Emission Reduction*.

H. Zero Waste Policy and Energy-Efficient

Zero waste policy is applied to minimize environment impact. Liquid waste is used for land application or organic fertilizer as part of compost ingredient. Fiber and shell are used for fuel to replace fossil fuel. Since fiber and shell are the result of carbon absorption, therefore carbon emitted from the combustion is not included in the carbon calculation or equivalent to zero. A case study from 12 plantations, utilization of fiber and shell to replace fossil fuel as business as usual (BAU) has resulted in saving emission about 508,53 ton CO₂-eq/year in average (See Table 5). Application of zero waste policy has brought palm oil industry to become industry with more energy-efficient and low-carbon cost.

Table 5. Emission saving from the replacement of fossil fuel (business as usual) by fiber and shell

No.	Conses sion.	Fiber +Shell usage to replace fossil fuel (ton)	Fossil fuel usage as BAU (L)	Emission Saving (ton CO ₂ -eq/year)
1	A	48,362	430,980	411.97
2	B	312,644	373,314	356.85
3	C	168,828	285,681	273.08
4	D	191,195	851,224	813.68
5	E	123,579	212,307	202.94
6	F	124,694	1,295,289	1,238.15
7	G	195,938	158,476	151.49
8	H	209,084	685,147	654.93
9	I	127,562	370,432	354.09
10	J	151,237	958,127	915.86
11	K	198,328	399,271	381.66
12	L	94,416	363,658	347.62

I. Palm Oil Industry and Community Welfare

Increasing growth of palm oil industries has brought benefits for local community by creating jobs for more than 2,8 million families or more than 5 million people in the field. From all people working in plantations, about 57% of them working in plantations owned by smallholder (See Fig 5). The benefits are not limited to the amount of income earned, but some facilities including water, electricity, housing, schools, and children care are provided for not only the worker but their families

included. The number of people benefited from the plantation will be bigger through multiplier effects (benefits not directly linked with palm oil industry).

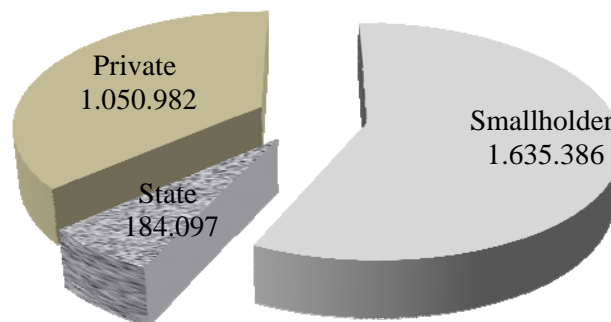

Fig. 5. Number of people working for plantation as main livelihood

The Government has also supported local community through plasma-nucleus scheme, where local community is involved to manage about 20% of the plantation, and about 2 ha will be given to participating single family. The participating company has provided assistance and trainings for participating families. Another scheme is local partnership voluntary developed by some companies with local independent smallholders where the program is implemented in their own land. The program is established to double the positive impact of plantation development toward local community. Both programs have successfully helped local community to raise their income (See Fig 6 and Fig 7). The partnership program does not only provide the capital for local community, but also assists them to manage their plantation in a better way. Result indicated that monthly income of joining farmers increased by year to year (Fig 7).

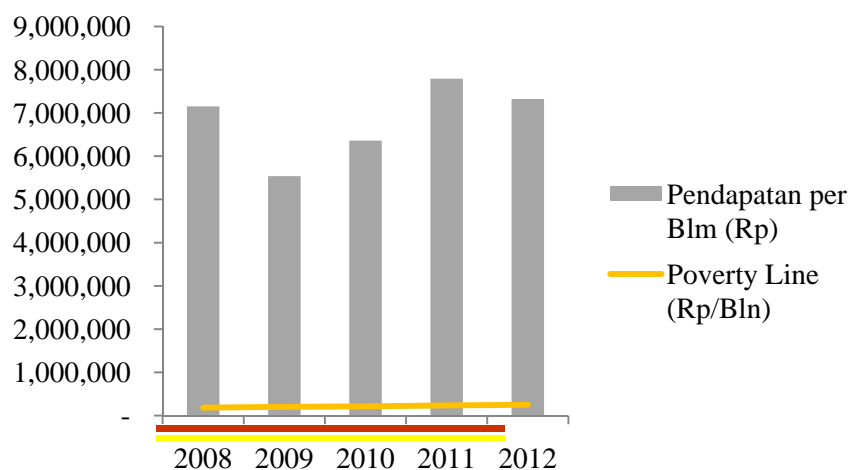

Fig 6. Monthly income earned by plasma farmers. The common international poverty line / poverty threshold (\$1,25 a day) or IDR 400.000 /month. Indonesia poverty line / poverty threshold IDR 248.000 /month (year 2012)

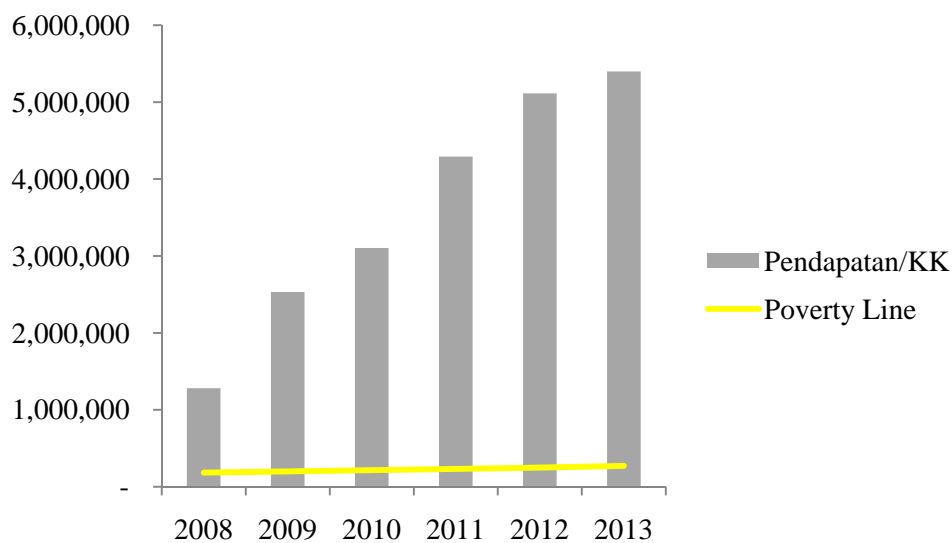

Fig 7. Montly income of farmer joining the partnership program.

J. Indonesian Sustainable Palm Oil Scheme

Sustainable issue of palm oil production has been discussed in the last 10 years. Officially the Government of Indonesia has launched Indonesian Sustainable Palm Oil (ISPO) system in 2011 as a policy adopted by the Ministry of Agriculture with the aim to improve the competitiveness of the Indonesian palm oil at the global market and contribute to the objective set by the President of the Republic of Indonesia to reduce greenhouse gases emissions and draw attention to environmental issues.

The system is regulated under Ministerial Decree No 19/Permentan/OT.140/3/2011. The ISPO scheme represents all system in Indonesia as regulated in various government regulations. In the other word, ISPO scheme is a compilation of all related government regulations. Every single company has to follow the scheme and the certificate would only be given for company who has fulfilled 100% principles and criteria under ISPO scheme. The ISPO scheme is comprehensive system by evaluating and reviewing overall aspects of palm oil production process including legal aspects of consession, best management system (labour, cultivation, etc), and corporate social responsibility and environment/ecosystem management. There are seven priciples, 41 criteria, and 127 indicators required to be fulfilled by company to get certified (See ISPO scheme under Ministerial Decree). The seven principles need to be met by proposing company are:

1. Consession permit and estate management
2. Implementation of the Guidance for Cultivation Techique and palm oil manufacture
3. Environment Management and Monitoring
4. Labour Responsibility
5. Social and Community Responsibility
6. Empowerment of local economic
7. Improvement of Sustainable Bussiness.

CONCLUSION

Substantially, Government of Indonesia has designed green system in every aspects of development especially for agriculture as it is expressed in various Government regulations. Implementation of green industry concept in palm oil industry is a good example to be learned since it holds a strategic role for food security, poverty alleviation, and economic development. At the same time, since palm oil production needs large scale land for cultivation, possible environment and social impact should be carefully managed. The ISPO scheme is the green system launched by the Government of Indonesia represent the substance of all related regulations. Implementation of ISPO would be the key as a green scheme to ensure the sustainability of palm oil production, ecosystem health and local community welfare.

REFERENCES

- Ministry of Agriculture. 2012. Indonesian Palm Oil Statistic. Jakarta: Ministry of Agriculture.
- Foster WA, Snaddon JL, Turner EC, Fayle TTM, Cockerill TD, Ellwod MDF, Broad GR, Chung AYC, Eggleton P, Khen CV, Yusah KM. 2011. Establishing the evidence base maintaining biodiversity and ecosystem function in the oil palm landscapes of South East Asia. *Phill. Trans. R. Soc.B.* 366:3277-3291. Doi: 10.1098/rstb.2011.0041
- Gunarso P, Hartoyo ME, Nugroho Y, Ristiana NI, Maharani, RS. 2012. Analisis Penutupan Lahan dan Perubahannya Menjadi Kebun Kelapa Sawit di Indonesia Tahun 1990-2010 (*Studi Kasus di 5 Pulau Besar di Indonesia*). [Report]: Bogor.
- Koh LP, Wilcove DS. 2007. Cashing in palm oil for conservation. *Nature.* 440: 993-994
- Koh LP. 2008. Can oil palm plantations be made more hospitable for forest butterflies and birds?. *Journal of applied ecology.* 45:1002-1009
- Koh LP. 2008. Birds Defends oil palm from herbivorous insect. *Ecological Application* 18(4):821-825
- Koh LP, Miettinen J, Liew SC, Ghazoul J. 2011. Remotely sensed evidence of tropical peatland conversion to oil palm. *PNAS* 108:5127-5232.
- UNIDO. 2011. UNIDO Green Industry, policy for supporting green industry. Vienna: Austria.
- Yaap B, Struebig MJ, Paoli G, Koh LP. 2010. Mitigating the biodiversity impacts of oil palm development. *CAB Reviews: Perspectives in Agriculture, Veterinary, Nutrition, and Natural resources.*

ECO-FRIENDLY AGROCHEMICAL PRACTICES TO SUPPORT GREEN AGRO-INDUSTRY

Nilda R. Burgos
Department of Crop, Soil, and Environmental Sciences
University of Arkansas, Fayetteville, USA

ABSTRACT

Green agro-industry is a crucial aspect of sustainable agriculture, which entails the use of eco-friendly pesticides. The green chemistry movement, initiated in North America and Europe and now also in a few developing countries, is expected to contribute significantly toward sustainable agro-industry. The agrichemical industry is producing synthetic pesticides that are less risky for the environment and non-target organisms not only to comply with stricter regulatory requirements, but also to be better stewards of our ecology and natural resources. The recent generation of pesticides is deemed more environmentally friendly than older chemistries. Naturally-derived pesticide choices for organic food production is also expanding, albeit slowly. The rapidly expanding knowledge base on plant genomics and gene function is showing great promise in helping us move toward 'green agriculture'. Gene silencing technology could produce insect- and disease-resistant plants and could combat herbicide-resistant weeds. There are great possibilities in the horizon for eco-friendly agrochemical tools.

WHAT IS GREEN TECHNOLOGY?

Green technology evokes images of pristine waters, clean air, productive soils, and lush vegetation. Green technology is a dynamic process that aims to achieve all these, by generating technologies that are least impactful and most regenerative to natural resources, organisms and environment in general. It encompasses sustainability, source reduction, innovation, and viability (<http://www.green-technology.org/>). Defined broadly, sustainability is the practice of harnessing resources today in a way that allows the same resources to be available to future generations. Sustainable development is development that meets the needs of the present without compromising the ability of future generations to meet their own needs (The UN Brundtland Commission, 1987). With respect to agriculture, this means producing enough food and fiber without depleting and polluting water resources, denuding forests, degrading and eroding soils, nor eliminating biodiversity. Embedded in the pursuit and practice of sustainable agriculture is the harmonization of the environment, social equity, and economic demands (UN, 2005; Adams 2006). Achieving this entails the integration of many aspects including waste minimization; developing new technologies that reduce our reliance on non-renewable fossil fuels, which powers agricultural mechanization; and technologies that produce less toxic agricultural chemicals. Sustainability entails practices to be viable in the long term with respect to economics and societal and environmental impact. Globally, the most critical issue that green technology addresses

is the efficient and viable generation of renewable energy. One aspect, which is of utmost significance to agriculture, is green chemistry. Large-scale food production requires pesticides, or chemicals that can kill disease-causing organisms, insect pests, and weedy plants. The world clamors for green agriculture. Green agriculture needs green pesticides. To date, many synthetic agriculture pesticides have favorable environmental profiles because of stricter registration criteria.

'GREENING' AGRICULTURE THROUGH GREEN CHEMISTRY

The US Environmental Protection Agency (US EPA) has launched a Green Chemistry Program (www.epa.gov/greenchemistry/), also equated to sustainable chemistry, in the early 1990s. The US EPA defines it as the design of chemical products and processes that reduce or eliminate the use or generation of hazardous substances (Anastas and Warner 2000). The goal is to use chemical products without causing pollution. Green chemistry abides by twelve basic principles among which are: waste prevention and minimization, design of safer chemical syntheses process, design of less toxic chemicals and use of safer solvents, increasing energy efficiency, and use of renewable feedstocks, among others (Anastas and Warner 2000). In 2011, it was forecasted that the chemical industry will save \$65.5 billion by 2020 through developments in green chemistry and that green chemistry will create market opportunities approaching \$100 billion (www.navigantresearch.com/). Many countries around the world now have green chemistry programs. The practice of green chemistry principally revolves around technological applications related to phytoremediation, waste water treatment, analytical tools, medical applications, nanotechnology applications, and development of alternative energy sources among others (Su et al. 2014; Zaidi et al. 2014). Although agricultural applications are less dramatic in scale, this global awareness and government support for green chemistry bodes well for the greening of agriculture. Because green chemistry espouses the production of less toxic compounds, this means that both the government and industry are working toward synthesis of safer pesticidal compounds and safer pesticide formulations.

LOW-RISK PESTICIDES

The use of pesticides carries a certain level of risk either to organisms and/or the environment. Risk can be immediate or can be discerned only over the long term. Immediate risk is easier to assess and is a preliminary determinant of toxicity or risk categorization while long-term risk is not yet known. Toxicity to humans and other terrestrial organisms, toxicity to aquatic life, mobility in soil or air, and persistence are major variables in risk assessment. The risk level is a product of pesticide toxicity and duration of exposure. The relative risk of a small subset of pesticides commonly used today is shown in Table 1. Of these, the only pesticide deemed not to carry any risk is *Bacillus subtilis* (for disease control), based on the variables mentioned previously. Insecticides with neem extract as active ingredient (biopesticide) do not have any risk for movement or persistence in soil, but are rated to carry intermediate risk to birds and bees and low-level risk to aquatic life and humans. In the US, minimum-risk pesticides

are exempt from registration with the EPA. Insecticides generally carry higher level of risk compared with fungicides and herbicides. For example, the synthetic herbicides fluazifop and glyphosate are classified as low-risk pesticides. The US EPA is implementing stricter pesticide regulations for registration such that old compounds that do not meet current registration criteria are no longer commercialized. Thus, pesticides today are generally more environmentally friendly.

BENEFITS OF GREEN CHEMISTRY

Foremost is the anticipated reduction of pollutants, resulting in cleaner air and water (www.epa.gov/greenchemistry/). This would result from the minimization of input materials, efficient and less toxic manufacturing processes, minimization of waste, and production of chemicals that are not toxic to animals and do not persist in the environment. Exposure of workers to hazardous materials will be reduced and society will enjoy safer food. Pesticides would have minimal or no impact on the environment. Green chemistry will also boost the economy because of increased efficiency in manufacturing, increased throughput, improved sales, elimination of expensive clean-up or remediation processes, and reduced reliance on nonrenewable petroleum products.

ORGANIC ALTERNATIVES: ARE THEY ALL 'GREEN'?

To be considered as an organic alternative in the USA, a pesticide must be approved first by the Organic Material Review Institute (OMRI). The review institute is a nonprofit organization that determines which input products are allowed for use in organic production and processing. The USDA National Organic Program regulates that only OMRI-approved products can be used by certified organic food growers. Several compounds are approved (www.omri.org), including some biopesticides. For this paper, biopesticide refers to pesticidal compounds derived from naturally occurring substances in microbes, plants, or genetically engineered plant protectants such as the *Bt* toxin expressed in insect-resistant crops. To date, the list includes about 260 fertilizer products, 150 insecticidal formulations, 40 fungicides, and 71 herbicides. Fertilizers include leguminous and various plant materials, guano, fish components, bones, chicken litter, and others. Insecticides include various products containing soap (the majority), sulfur- and copper-based formulations, Bt-based products, Neem oil/extracts, and limonene. Fungicides also include copper- sulfur- and neem(or other plant) extract- and soap-containing products, which control both insects and diseases; microbial products; hydrogen peroxide; sodium carbonate peroxyhydrate; potassium bicarbonate; potassium silicate; peracetic acid; fermentation products, and trichoderma. Herbicidal products contain either limonene, soap, boric acid, ferric/ferrous materials, citric acid, clove oil, copper sulfate, or non synthetic herbicidal compounds. It should be noted that some of these organic pesticides such as copper-based products (<http://pmep.cce.cornell.edu/profiles/extoxnet/carbaryl-dicrotophos/copper-sulfate-ext.html>) carry high phytotoxic risk to organisms or, could accumulate in soils with detrimental effects. Other products such as peracetic acid (<http://toxnet.nlm.nih.gov/cgi-bin/sis/search/a?dbs+hsdb:@term+@DOCNO+1106>), and sodium carbonate

peroxyhydrate

(<http://dnr.wi.gov/lakes/plants/factsheets/SodiumCarbonatePeroxyhydrateFactsheet.pdf>)

have not been thoroughly studied with respect to concentrations used for pest control nor tested at these levels for side-effects animals and humans.

Organically approved herbicidal products are generally non-selective, without residual activity in soil (postemergence activity only), less effective than synthetic herbicidal compounds, and applied at high spray volumes such as indicated in a limonene-based formulation (<http://www.norganics.com/label/GMSpecimenLabel.pdf>). These products can be used only prior to planting the crop, or directed to the crop base (postemergence-directed) to avoid crop injury. Natural toxins (allelochemicals) from plants or microbes are good candidates for commercial biopesticide formulations because these could be broad spectrum, although obtaining a herbicidal compound with soil activity would be a rare possibility. Although not classified as 'organic' pesticides, glufosinate (from microbe), mesotrione (from plant), azoxystrobin (from fungus) are examples of pesticides derived from natural sources and then commercially synthesized. To obtain an 'organic' label, a pesticide must still be naturally produced, such as being purified from microbial cultures. One example of this is the natural toxin, ophiobolin A derived from cultures of *Helminthosporium gramineum* Rabenh (Duan et al. 2006; Zhang et al. 2007). Ophiobolin A is both fungicidal and herbicidal. In field testing, it controls the causal agent for rice sheath blight, *Rhizoctoniasolani* (Duan et al. 2006). A 2.5% mixture of the crude toxin reduced fresh biomass of *Echinochloa crus-galli* about 75% in the field. It also shows activity on other rice weeds including monochoria (*Monochoriavaginalis*), false loosestrife (*Ludwigiprostrata*), Indian rotala (*Rotalaindica*), and sedge (*Cyperusdifformis*) (Zhang et al. 2007). Ophiobolin A is not toxic to brassica, corn, cotton, rice, and wheat (Zhang et al. 2007). Preliminary field studies show compatibility of ophiobolin A with rice herbicides (Liuqing Yu, Weed Scientist, China National Rice Research Institute, pers. communication) which allows for further broadening of weed control spectrum and increasing overall weed control efficacy. However, before this compound gains registration approval, it also must pass regulatory requirements to define its potential impact on non-target organisms (including humans) and the environment. Many allelochemicals cannot pass the regulatory criteria.

There are few effective bioherbicides. One example is Collego® (recent trade name, LockDown™), which was developed by researchers at the University of Arkansas-Fayetteville, USA in the early 1980s in collaboration with Upjohn Company (Tebeest and Templeton 1985). COLLEGO® is used to manage northern joint vetch, *Aeschynomene evirginica* (L.). B.S.P. a leguminous weed in rice and soybean crops in the US mid-south - Arkansas, Mississippi, and Louisiana. It is a formulation of fungal spores of *Colletotrichum gloeosporioides* [Penz.] Sacc.f. spp. *aeschynomene* (Coelomycetes). COLLEGO® is a wettable powder of dried spores sold in three components: (1) the spore powder, (2) a hydrating liquid, and (3) activated charcoal to clean spray tanks. The fungal spore suspension is sprayed in rice fields by ground or aerial applicators, preferably when foliage is moist or humidity is high. The fungus causes anthracnose disease that can kill both seedling and mature *A. virginica* plants. It is generally >90% effective. A major limitation of this type of technology, which limits its market share, is its specificity – it can control only one species. The same could be said about other biocontrol agents such as the application of fungal spores of *Alternaria*

sp. to control another rice weed *Sphenocleazeylanica* (Mabbayad and Watson 2007), or using insects to control a weedy species (Gayton and Miller 2012; Kok, 2001).

Thus, there are tradeoffs that growers have to consider. Overall, there are OMRI-approved chemical alternatives for insect and disease control that are as effective as the synthetic standards, but there is a dearth of more effective/broad-spectrum OMRI-approved herbicides. Although current organic alternatives for weed control are generally not as effective as synthetic herbicides, these alternatives offer relief to otherwise labor-intensive and costly mechanical- or hand-weeding.

THE IR-4 BIOPESTICIDES AND ORGANIC SUPPORT PROGRAM

The US-based, IR-4 Project facilitates registration of biopesticides for specialty crops and minor uses (<http://ir4.rutgers.edu/biopesticides.html>) in collaboration with the US EPA. Although not many compounds arrive at this stage, there have been some notable achievements. One is the registration of a biofungicide derived from giant knotweed (*Reynoutriasachalinensis*) in 2005 under the trade name Milsana®. It is as effective as synthetic fungicide products on the same disease spectrum infecting a wide array of crops including citrus, vegetables, leafy greens, tree fruits, grape vines, nuts and ornamentals. This biofungicide is now marketed by Marrone Bioinnovations, Inc. under the trade name Regalia® and is awarded the 'Best New Biopesticide' in 2010. Information about other biopesticides are available in the IR-4 (<http://ir4.rutgers.edu/Biopesticides/LabelDatabase/biopesticides2.cfm>).

It is generally believed that food crops produced only with biopesticides are risk-free. This is not always true. Unless the biopesticide has been tested for their potential impact to humans and the environment, we cannot say for certain that such compound is risk-free. In fact, the use of sulfur-based products to control diseases carries some risk to humans and aquatic life (Table 1). The same is true for the natural insecticide containing *Bacillus thuringensis* (Bt) or neem extract and the organically approved herbicide acetic acid.

GENE SILENCING PESTICIDES

Recent advances in science and technology have made possible the development of a novel pest control (disease, insect, weed) technology, through applications of the gene silencing phenomena. Gene-silencing pesticide targets a specific pest species, without harming others (Baum et al. 2007; Huang et al. 2006; Mao et al. 2007; Qu et al. 2007). Gene silencing is one of the outcomes of epigenetic processes of gene regulation, when the message coded for by RNA is not translated to a protein. Silencing could occur during (Park et al. 1996) or after protein transcription (Lindbo et al. 1993; Napoli et al. 1990). Post-transcriptional, sequence-specific gene silencing is triggered by double-stranded RNA (dsRNA), which destroys mRNA in a process commonly known as RNA interference, or RNAi (Baulcombe 2004, 2005; Hannon 2002). In the presence of

dsRNA and a Dicer enzyme, small RNAs [microRNA (miRNA), small interfering RNA (siRNA)] are produced. The mechanism of RNA interference was first elucidated by Fire et al. (1998). Soon it was learned that small RNA molecules can bind to mRNA and can prevent protein production (Hammond et al. 2000). Pest control applications of gene-silencing technology include feeding a target insect pest (e.g. *Diabrotica virgifera*, western corn rootworm) with dsRNA, resulting in larval stunting and mortality; or genetically engineering plants to express pest-specific dsRNA to reduce insect or disease infestation (Baum et al. 2007). Silencing a cytochrome P450 gene (*CYP6AE14*), which allows *Helicoverpa armigera* (cotton bollworm) to detoxify gossypol from ingested cotton tissue, by feeding the bollworm with cotton tissue expressing dsRNA specific to *CYP6AE14*, drastically reduced transcript levels of *CYP6AE14* and reduced larval growth (Mao et al. 2007). The efficacy of ingesting dsRNA on silencing a specific gene in a pest was first discovered with nematodes (*Caenorhabditis elegans*) (Timmons and Fire 1998). Similarly, Huang et al. (2006) demonstrated that genetically engineering *Arabidopsis thaliana* to express dsRNA of a root knot nematode parasitism gene, *16D10*, silenced the parasitism gene and conferred broad resistance to four major root knot nematode species. This type of wide range resistance is not naturally found in crop plants. The same principle has been used to confer plant resistance to viral infection (Qu et al. 2007).

A novel application of the gene silencing technology is reversal of resistance to pesticides. To combat glyphosate-resistant weeds, Monsanto has developed BioDIRECT™ technology. This involves spraying plants with a mixture of dsRNA specific to the glyphosate target gene, *EPSPS* (5-enolpyruvylshikimate-3-phosphate synthase)

(<http://www.monsanto.com/products/pages/biodirect-ag-biologicals.aspx>). Field testing of this technology was first conducted in the USA in 2011 and demonstrated that glyphosate-resistant *Amaranthus palmeri* (Palmer amaranth) became sensitive to glyphosate when topically treated with EPSPS-specific dsRNA (D. Sammons, Monsanto Co., personal communication).

The debate is on whether gene silencing pesticides are eco-friendly or, or minimum-risk tools for green agro-industry. Off-target effects are possible due to partial homology of miRNA to other genetic regions, causing cleavage of mRNA (Bartel 2004). Because this is a relatively new field of science, little is known about the stability and off-target effects of gene silencing.

REFERENCES

- Anastas, P. T. and Warner, J.C. 2000. Green Chemistry: Theory and Practice. Oxford University Press, USA. 152 pp.
- Adams, W.M. 2006. "[The Future of Sustainability: Re-thinking Environment and Development in the Twenty-first Century.](#)" Report of the IUCN Renowned Thinkers Meeting, 29–31 January 2006. Retrieved on: 2009-02-16.
- Bartel, D.P. 2004. MicroRNAs: genomics, biogenesis, mechanism, and function. Cell 116:281-297.
- Baulcombe, D. 2004. RNA silencing in plants. Nature 431:356-363
- Baulcombe, D. 2005. RNA silencing. Trends Biochem. Sci. 30:290-293.

- Baum, J.A., Bogaert, T., Clinton, W., Heck, G.R., Feldman, P., Ilagan, O. Johnson, S. Plaetinck, G., Munyikwa, T., Vaughn, T., and Roberts, J., 2007. Control of coleopteran insect pests through RNA interference. *Nature Biotechnol.* 25(11):1322-1326.
- Dalal-Clayton, Barry and Sadler, Barry 2009. *Sustainability Appraisal. A Sourcebook and Reference Guide to International Experience*. London: Earthscan. [ISBN 978-1-84407-357-3](#).
- Duan, G., Zhang, Z., Zhang, J., Zhou, Y., Yu, L. and Yuan, Q. 2006. Evaluation of crude toxin and metabolite produced by *Helminthosporiumgramineum* Rabenh for the control of rice sheath blight in paddy fields. *Crop Prot.* doi:10.1016/j.cropro.2006.09.014
- Fire, A., Xu, S., Montgomery, M.K., Kostas, S.A., Driver, S.E., and Mello, C.C. 1998. Potent and specific genetic interference by double-stranded RNA in *Caenorhabditiselegans*. *Nature.* 391:806-811.
- Gayton, D. and Miller, V. 2012. Impact of biological control on two knapweed species in British Columbia. *J Ecosys. and Manag.* 13(3):1–14.
- Hammond, S. Bernstein, E. Beach, D.m and Hannon, G. 2000. An RNA-directed nuclease mediates post-transcriptional gene silencing in *Drosophila* cells. *Nature.* 404(6775):293-296.
- Hannon, G. J. 2002. RNA interference. *Nature* 418:244-251.
- [Hofer, U.](#) ; [Butel, D.](#) ; [Campagna, C.](#) ; [Gorrochategui, A.](#) ; [Mills, C.](#) ; [Raffel, H.](#) ; [Tatnell, J.](#) 2005. Challenges and solutions for annual grass weed management in small grain cereals in Europe. [Proc. 13th EWRS Symposium, Bari, Italy, 19-23 June 2005](#), unpaginated.
- Huang, G., Allen, R., Davis, E.L., Baum, T.J., and Hussey, R.S. 2006. Engineering broad root-knot resistance in transgenic plants by RNAi silencing of a conserved and essential root-knot nematode parasitism gene. *PNAS.* 103(39):14302-14306.
- Kok, L.T. 2001. Classical biological control of nodding and plumeless thistles. *Biol. Control* 21, 206–213.
- Lindbo, J., Silva-Rosales, L., Proebsting, W. and Dougherty, W. 1993. Induction of a highly specific antiviral state in transgenic plants: Implications for regulation of gene expression and virus resistance. *Plant Cell.* 5:1749-1759.
- Mabbayad, M. O. and A. K. Watson. 1995. Biological control of gooseweed (*Sphenocleazeylanica* Gaertn.) with an *Alternaria* sp. *Crop Prot.* 14(5):429-433.
- Mao, Y.B., Cai, W.J., Wang, J.W., Hong, G.J., Tao, X.Y., Wang, L.J., Huang, Y.P., and Chen, X.Y. 2007. Silencing a cotton bollworm P450 monooxygenase gene by plant-mediated RNAi impairs larval tolerance of gossypol. *Nature Biotechnol.* 25(11):1307-1313.
- Napoli, C. Lemieux, C. and Jorgensen, R. 1990. Introduction of a chimeric chalcone synthase gene into petunia results in reversible co-expression of homologous genes *in trans*. *Plant Cell.* 2:279-289.

- Park, Y-D., Moscone, E.A., Iglesias, V.A., Vaucheret, H., Matzke, A.J.M., and Matzke, M.A. 1996. Gene silencing mediated by promoter homology occurs at the level of transcription and results in meiotically heritable alterations in methylation and gene activity. *Plant J.* 9:183-194.
- Qu, J., Ye, J., and Fang, R. 2007. Artificial microRNA-mediated virus resistance in plants. *J Virol.* 81(12):6690-6699.
- Senior, I.J. 1998. Uses of plant gene silencing. *Biotechnol. and Genet. Eng'g. Rev.* 15(1):79-120, DOI:[10.1080/02648725.1998.10647953](https://doi.org/10.1080/02648725.1998.10647953)
- [Su, Y.](#), [Xie, Y.](#), [Hou, X.](#), [Lv, Y.](#) 2014. Recent Advances in Analytical Applications of Nanomaterials in Liquid-Phase Chemiluminescence. *Applied Spectroscopy Reviews.* 49(3):201-232.
- TeBeest, D. O., and G. E. Templeton. 1985. Mycoherbicides: Progress in the biological control of weeds. *Plant Dis.* 69:6-10.
- Timmons, L. and Fire, A. 1998. Specific interference by ingested dsRNA. *Nature.* 395:854.
- United Nations General Assembly (March 20, 1987). "[Report of the World Commission on Environment and Development: Our Common Future](#); Transmitted to the General Assembly as an Annex to document A/42/427 - Development and International Co-operation: Environment; Our Common Future, Chapter 2: [Towards Sustainable Development; Paragraph 1](#)". [United Nations General Assembly](#). <http://www.un-documents.net/ocf-02.htm>. Accessed: Sept. 29, 2013
- [United Nations General Assembly](#). 2005. [2005 World Summit Outcome](#), Resolution A/60/1, adopted by the General Assembly, 15 September 2005. http://data.unaids.org/Topics/UniversalAccess/worldsummitoutcome_resolution_24oct2005_en.pdf Accessed: Sept. 29, 2013
- [Zaidi, N.S.](#), [Sohaili, J.](#), [Muda, K.](#) and [Sillanpää, M.](#) 2014. Magnetic field application and its potential in water and wastewater treatment systems. *Separation & Purification Reviews.* 43(3):206-240.
- Zhang, Z. B., Burgos, N. R. , Zhang, J. P. and Yu, L. Q. 2007. Biological control agent for rice weeds from protoplast fusion between *Curvularialunata* and *Helminthosporiumgramineum*. *Weed Sci.* 55:599–605.

Table 1. Toxicological comparison of selected pesticides.
Adapted from Product Toxicity Comparisons.^a Accessible at
<http://www.austintexas.gov/sites/default/files/files/Watershed/growgreen/products.pdf>

Pest target category	Active ingredient	Human toxicity		Aquatic life	birds, bees, vertebrates	Mobility in soil	Persistence in soil
		Acute	Chronic				
diseases	<i>Bacillus subtilis</i>	0	0	0	0	0	0
diseases	mycobutanil	X	XX	XXX	XXX	X	X
diseases	sulfur	X	?	X	0	0	N/A
diseases	tebuconazol	X	0	XX	0	X	X
insects	<i>Bacillus thuringensis</i>	X	0	X	X	0	0
insects	bifenthrin	X	?	XXX	XX	0	X
insects	carbaryl	X	XX	XXX	XXX	XX	XX
insects	fatty acid soap	X	?	X	0	0	0
insects	imidacloprid	X	?	XXX	XX	XX	XX
insects	lamda-cyhalothrin	XX	X	XX	XX	X	XX
insects	malathion	X	?	XX	XXX	0	X
insects	neem extract	X	?	X	XX	0	0
insects	permethrin	X	XX	XXX	XXX	0	X
insects	spinosad	X	?	XX	XX	0	X
weeds	acetic acid	XXX	?	X	0	0	0
weeds	atrazine	X	XX	XX	0	XXX	XX
weeds	fluazifop	0	?	X	0	0	0
weeds	glyphosate	X	?	X	0	X	0
weeds	imazaquin	X	?	X	0	XXX	XX
weeds	pendimethalin	X	0	XX	X	0	XX
weeds	triclopyr	X	X	XX	X	X	0
weeds	trifluralin	X	?	XXX	X	0	X

^aToxicity level: 0 = low; X = moderate; XX = high; XXX = highest; N/A = not applicable; ? = not known

SUSTAINABLE HORTICULTURE SUPPLY CHAINS

T. Hattink

Department of Horticulture, HAS University of Applied Sciences,

Den Bosch, the Netherlands

t.hattink@has.nl

ABSTRACT

A secure world food supply requires the transition of our agro-food system towards maximum sustainability of production and supply chains. This article describes some specific characteristics of supply chains in horticulture, and attempts to assess whether they make potential candidates for improvements in sustainability. Furthermore, this article also addresses the technical possibilities of an existing plant-growing system in conditions where there is an abundance of renewable energy.

INTRODUCTION

This contribution is not the result of specific research on the topic, but is a reflection on current thinking on the subject of sustainable supply chains in horticulture. The perspective is that of a Director of Studies at an agricultural university in the Netherlands, which offers traditional programmes in Horticulture and Agribusiness alongside a new curriculum, designed specifically to address the challenge of improving the sustainability of food supply chains.

Since it was founded in 2012, this new programme, entitled International Food and Agribusiness, has attracted over 60 enthusiastic students from countries as far afield as South East Asia and South America. In spite of their diverse backgrounds, each one shares a commitment to the subject and a passion to making a real contribution to tackling the issues covered, whether as an engineer, and entrepreneur or as an international consultant. These students will have to be prepared to work in an international setting, as most of the supply chains cover several countries and continents. In fact, most of the food that is consumed in the Netherlands is produced elsewhere. Interestingly the reverse is also true, with the Netherlands being the world's second largest exporter of food products.

A Major Challenge

Safeguarding world food supply is becoming a major challenge. Scarcity of land and depletion of resources are limiting productivity, and causing the cost of food production to rise. Combined with the growing demand for agricultural resources, especially for protein-rich diets which are highly input intensive, this is leading to unprecedented challenges for our food system." Two times more with two times less" is the current saying in the Netherlands, referring to the challenge for the coming decades to produce twice the quality of agricultural commodities from only half the input.

This is a challenge for which there is no simple solution. It involves addressing the technical challenges in plant breeding, crop production, post harvesting and logistics. It is about reducing food waste and food losses. But it is also about power balances in supply chains, between buyers and sellers. It is also about a country's ability to feed its population, and we have seen governments react with food pricing policies that have removed incentives for farmers to invest in their production. It is about an individual's choice regarding what they want to eat, but at the same time consideration of how this personal choice affects others across the globe. Dutch scientist, writer and former assistant Director General of the FAO, Louise Fresco writes, "the impact of all the choices we make with respect to food resonates across the globe" [1].

B. Sustainable Supply Chains

Using the Brundtland definition, sustainable food supply chains would be those supply chains in which actors are able to manage the production and flow of food, taking into account the 3 dimensions of sustainable development (People, Planet, Profit) in a way that the ability of future generations to provide for their food is not compromised [2]. To put this definition into practice means for individual actors, as well as for the chain as a whole, to address these challenges:

1. how to measure the impact of the chain on environmental, economic and societal factors in an integrated way
2. which managerial, logistic and technical improvements have to be implemented to achieve a lower negative environmental and social impact
3. how to organise a cooperative structure and a transaction model within the supply chain that provide the coordination needed for an outcome in which all actors benefit

In literature, evidence can be found for the hypothesis that successful sustainable supply chains combine the same managerial, logistics and technical qualities that would have made them equally successful as traditional (non-sustainable) supply chains, but that in addition

1. the management of the organisations involved shares a deep-rooted belief in the benefits to be gained for their companies in addressing the sustainability issue
2. they succeeded in adopting a cooperative model in which all actors in the supply chain work closely together and are involved in each other's business, and even in each other's operations

Pagell and Wu [3] mention the 'reconceptualisation' by firms in successful sustainable supply chains, of who exactly is part of their supply chain, leading firms to use the skills and networks of NGOs and other stakeholder groups.

C. The Case Of Energy

Before addressing some specifics of sustainable supply chains in horticulture, it is interesting to consider that what we refer to as the 'food security challenge', may not really about food at all. To avoid wasting valuable effort and resources in attempts to fix something that is not broken, it is important to clarify this point. *The issue may not be one of a food system problem, but rather of an energy problem.*

Energy and food production systems are interlinked in at least two ways:

1. the use of land across the globe is being constantly reassessed for use for energy or for food production. And with the Western consumers' ability to pay more for one tank of gas than African refugees can pay for their carbon uptake for a whole year (which is about the same energy equivalent), it is an uneven struggle
2. food production depends heavily on the input of expensive fossil fuels, and often involves the problems of countries with little foreign currency

It seems that as long as the energy crisis is unresolved, world food security will remain highly uncertain. But there is a positive side to this discussion: in a future with cheap and renewable energy, derived from efficient solar cells for example, it may be possible to address the food challenge in high-tech installations in which LED lighting and zero-waste recycling safeguard food production. HAS University of Applied Sciences is involved in developing such technology, using 8 climate chambers, in which all the growing parameters are carefully controlled. The ideas behind this approach are as follows:

1. In regular plant production systems, plant growth is probably limited by most growing parameters, sunlight being certainly one. In these systems, only 25% of the time available is used effectively by the plant for photosynthesis (Figure 1, irradiance rates between 50-488 $\mu\text{mol}/\text{m}^2\cdot\text{s}$). The remaining 75% of the time, there is little or no light available ($<50 \mu\text{mol}/\text{m}^2\cdot\text{s}$), or there is excessive heat-stress during the daytime ($>488 \mu\text{mol}/\text{m}^2\cdot\text{s}$).
2. In closed plant production systems, 100% controlled, and with the application of optimum wave lengths through LED lights, plant growth is limited solely by the crop's own genetic disposition.
3. In open plant production systems, water and nutrients uptake is only a very small proportion of what is applied.
4. Controlled systems can lead to a 90% reduction in water usage, 100% efficiency in nutrient application, more controllable metabolic processes and consequently healthier products. Crop protection products are no longer needed, because of an elimination of diseases.

In controlled systems, as a result of optimal photosynthesis, dry matter production can be about 200 g/m² fresh weight per day for leafy vegetables, compared to an average of 50 -100 grams per day in normal production systems measured over a year (Figure 2) [4].

hour of the day	Jan	Feb	Mar	Apr	May	June	July	Aug	Sep	Oct	Nov	Dec
1	0	0	0	0	0	0	0	0	0	0	0	0
2	0	0	0	0	0	0	0	0	0	0	0	0
3	0	0	0	0	0	0	0	0	0	0	0	0
4	0	0	0	0	0	6	0	0	0	0	0	0
5	0	0	0	0	30	72	42	6	0	0	0	0
6	0	0	0	48	155	227	161	72	12	0	0	0
7	0	0	36	191	346	412	340	239	113	18	0	0
8	0	30	155	388	561	627	526	442	293	119	18	0
9	36	137	388	573	758	824	699	633	502	269	102	36
10	125	281	478	729	926	973	860	788	657	418	203	125
11	221	400	603	818	1027	1099	950	890	770	514	281	197
12	275	466	657	896	1075	1165	1027	968	824	543	305	239
13	287	478	657	878	1057	1177	1009	979	806	538	293	233
14	245	424	603	836	985	1105	973	926	729	478	227	179
15	155	334	508	723	878	985	878	830	621	358	137	90
16	60	191	370	567	729	848	747	687	448	203	48	24
17	6	66	209	376	543	639	591	496	257	60	6	0
18	0	6	60	197	340	442	514	281	90	6	0	0
19	0	0	0	48	149	239	203	96	6	0	0	0
20	0	0	0	0	24	78	54	12	0	0	0	0
21	0	0	0	0	0	6	0	0	0	0	0	0
22	0	0	0	0	0	0	0	0	0	0	0	0
23	0	0	0	0	0	0	0	0	0	0	0	0
24	0	0	0	0	0	0	0	0	0	0	0	0

Fig 1. Radiation in a standard Dutch greenhouse ($\mu\text{mol}/\text{m}^2\cdot\text{s}$ per hour of the day)

Crop	Fresh crop production in g m^{-2} per day	Dry matter production in grams per mol PAR-light
Lettuce, <i>Lactuca sativa</i>	190	1.20
Rucola, <i>Erucola sativa</i>	93	0.42
Dill, <i>Anethum graveolens</i>	158	1.20
Basil, <i>Ocimum basilicum</i>	105	0.60

Fig. 2. Fresh crop production in climate chamber

Challenges of the controlled system are, of course, the investments needed, as well as the energy costs. Technically, pollination is also an issue. The systems are already used by breeders, to shorten their development time for new cultivars, and by companies to produce seed or young plants. For some leafy vegetables and herbs, this solution is already competitive and in commercial use in Japan, where retail prices are much higher than in the Netherlands. For grains, tubers and fodder crops it may never be an option.

There are those who believe that, within a few years, this technology will be used by retail stores in large cities to offer a fresh supply of safe vegetables daily. What consumers will have to overcome is the notion that they want their relationship with nature to be reflected in the food they eat i.e. not coming from something that looks like a factory. But there is one consolation at the moment, namely the high numbers of consumers that are struggling with their diet, and want their food to be as healthy and safe as possible, which of course is easier to achieve in a controlled environment. And developments like this can bring agricultural production back into cities, which may further help shape consumer attitudes towards healthy and fresh food

D. Sustainable Supply Chains In Horticulture: A Quick-Scan

So what are the implications for sustainable supply chains in horticulture? What are their specific characteristics? What challenges and what perspectives can we identify? The framework used in this quick scan looks at some important identifiers of supply chains and tries to determine whether the specific attributes in horticulture make them a hopeless case for improving sustainability, or represent a promising starting point for improvement.

The two most important criteria used to determine the chance of the success or failure of a supply chain will be

- the return on investment, to be expected from improvements in the supply chain
- the need for the dominating enterprise to cooperate throughout the chain to capitalise this return on investment

1. Perishable goods

There is the huge problem of food losses throughout the chain. In some fresh supply chains about 50% of a harvest can be lost in collecting, storing, shipping and distribution. A challenge that certainly needs addressing in many countries is the problems small-scale producers face in getting their fresh products to market in time. Over the past century in the Netherlands, people have been able to develop farmer-owned cooperatives. And this is where all the progress has been achieved. Dutch cooperatives in dairy, meat and flower distribution are among the leading enterprises in the world.

Cooperation in any form brings in the leverage needed to solve this problem. Most actors in a supply chain share a common interest to keep cost-inflating losses to a minimum. The perishable nature of fruit and vegetables makes them unattractive to speculate with. So there is no fundamental problem to overcome in this respect. Nevertheless, practical challenges abound.

2. Differentiating product attributes

We are currently seeing a two-way development in agro-food business in Europe with, on the one hand, multinationals and conglomerates operating in a way that almost seems to deny the concepts of distance, boundaries and nations and, on the other hand, the development of local-for-local production, based on added value.

The fruit and vegetable segment is one of added value. Fruit and vegetables bring something extra to a meal, or to a moment. We are, therefore, talking about products whose attributes are often carefully considered by consumers before buying. It is also a segment with a great deal of variety: a wide choice for producers and retailers, offered by a relatively large number of growers, and with relatively high-tech production methods and post-harvest handling.

And this gives way to the possibility of obtaining a price premium for products that distinguish themselves, at least for part of the consumer market. So, in an effort to make chains more sustainable, which demands investments, certainly in the earlier stages,

there is the promise that the price difference will be paid by consumers at the end of the chain, and not simply form an additional cost for the other actors.

Some challenges here are:

- a. for growers to address the issue of good productivity under low input conditions
- b. for producers to safeguard maximum quality and safety, especially if brands are to be established
- c. for retailers to market these attributes together with other attributes such as taste or local origin
- d. for the chain as a whole to find transaction models where all actors in a chain benefit

There is a successful example in the Netherlands, where a vegetable breeder and a retailer combined their efforts to launch new vegetable cultivars and worked together with a limited number of producers. Three years ago, the same breeder took this initiative to China, aiming to expand the business there, working closely with retailers and growers.

3. The chain is retail driven

Other than in staple foods, where supply chains are mostly dominated by traders, most vegetable and fruit markets are retail driven and often local. And it is here that we can see some theoretical advantages, because retailers are able to differentiate between products and pay the producer a price bonus for efforts to improve sustainability. The Carrefours of this world have a reason to pay attention to public opinion, and a rise or fall of 2% in the numbers of visitors to their hypermarkets because of the company's sustainability policy, will certainly affect operations.

These companies really know their customers. And they are smart advertisers. So if they can get a nation to buy 64 different kinds of cookies, they should be able to encourage them to opt for fresh, healthy and honest products - and to pay for it. However, in reality we are only seeing minor improvements. Retailers look uncertain, unaware of their influence and responsibility. It is likely that they will increasingly attract the indignation of the public and government in the near future. Currently, a Dutch activist group is being rather successful in naming and shaming retailers on national radio for their lack of concern for welfare of the chicken they sell.

4. Coordination mechanisms

There is the advantage of large retailers being able to introduce coordination mechanisms in supply chains to improve sustainability, which would otherwise be too complex. Thousands of small, unorganised producers of fruit and vegetables cannot conduct market research or launch market campaigns. They cannot introduce standards and controlling systems for sustainability, and are coping too much with today's reality to be able to think 5 or 10 years in future. But retailers like Tesco can, and they do. In the Netherlands, we are seeing large retailers starting to move and take the initiative. It may be slow, but it is a start.

CONCLUSION

One might think that in a world with a shortage of food and land, farmers would be the lucky ones, being able to squeeze out a decent living from the difference between the cost of production and the market price. But often in a chain with unequal power balances, this is not the case.

Hopefully, this contribution has succeeded in making the point that some fundamental attributes of fresh food supply chains give reason to believe that improving sustainability may bring rewards to entrepreneurs operating in this chain. Our concern here should be with the small farmers, so efforts of governments and the energy of researchers should aim to make a genuine contribution to the opportunities for small farmers to continue farming, and to participate in supply chains with decent returns for their business. Without doubt, it is with the primary producers that most of the scarce resources for fresh products are invested. This is, therefore, the place where the majority of the investments in sustainability will need to be made, and it is here that we must look for the reward in the form of the Sustainable Horticulture Supply Chains we so much need.

REFERENCES

- Fresco, L. O.: Hamburgers in het paradijs, Bert Bakker, 2012, p 11
- World Commission on Environment and Development: Our Common Future. Oxford University Press, 1987, p. 27
- Pagell, M. and Wu, Z.: building a more complete theory of sustainable supply chain management using case studies of 10 exemplars. *Journal of Supply Chain Management*, 45: pp 37–56
- Besten, den, J.: Results of climate chamber research, unpubl. 2013

ZERO WASTE TECHNOLOGY IN GREEN AGRO-INDUSTRY: SPECIAL CASE FOR PALM OIL INDUSTRIAL CLUSTER

E. Gumbira-Sa'id⁽¹⁾
(Professor in Agroindustrial Technology)
Chairman of The Indonesian Oil Palm Society (MAKSI))
Donald Siahaan⁽²⁾, Sapta Raharja⁽¹⁾, A.S. Fahmil Qowim⁽¹⁾, Sarono⁽¹⁾,
Lya Agustina³ and J.R. Amelia¹

Dep. Agroindustrial Technology, Fateta, Bogor Agricultural University⁽¹⁾, Indonesian Oil
Palm Research Institute⁽²⁾ and University of Lambung Mangkurat⁽³⁾

(*) Invited paper for International Conference On Green Agro-Industry
(ICGAI), Yogyakarta, Indonesia 11- 14 November 2013.

INTRODUCTION AND THEORITICAL BACKGROUND

Agriculture is one of the most important sector to support human life. Agroindustry also has important roles in producing food, feed, building materials, pharma and nutraceuticals, as well as energy. Indonesian government has been developing oil palm plantation since early 1960's and the industry has now been growing strongly. Today oil palm becomes one of the Indonesian prior commodities, and it is getting more important to safe agricultural produces, to increase quality and added value of the consumer needs products. Sustainability of palm oil is crucial if this versatile crop is to become the leading vegetable oil in this world (Tan, 2009). Due to global challenges in the area of vegetable oils compotition and trade, sustainable oil palm agroindustry development in Indonesia is important , as well as the development of zero waste technology within the agroindustry boundary.

Large scale production of an agroindustry discharges excessive amount of agricultural waste of different kind and forms. These agro industrial wastes mainly consist of organic matters which, through clean technology can be recycled by integrated waste utilization or simply returned to the place of their origin. In this article some of Indonesian palm oil industrial cluster wastes are reviewed. Palm oil industrial clusters in Indonesia have been developed since 2006 in three locations, namely Sei Mangkei, Dumai-Kuala Enok and Maloy (Pahan *et al.*, 2011).

Agro industrial wastes can be managed to be recycled, or be transformed into other products, which have value added. These options for Agro industrial wasteprocessing are reduce, reuse, recycle and recove. Clean technology can be implemented to minimize the waste, thereby increasing productivity and reducing the unit cost of product. The basic guidance for zero waste technology are:

- Maximizing the raw materials of agricultural produces (harvest)
- Converting commodity (ies) to various higher value products – avoid to produce only one product from one commodity
- Always considering the optimum pathway of conversion based on the values of products mapped on the “Three of Industry”
- Considering the by-products as raw material for other products development

- Considering the use of Life Cycle Assessment (LCA).

On the hand, there are several options of agricultural harvest yield to consumers products, such as the followings:

- Preservation: utilizing salts, sundrying, low temperatures (chilling etc.)
- Processing (size reduction, pasteurization, sterilization, freezing,
- Packaging (canning/bottling, vacuum packing etc.) and Labelling
- Utilizing microbial and enzymatic processes (bioprocessing)
- Thermal Heating and Processing: for solid biomass (wood panel, charcoal, carbon active etc.)

There are several agricultural products that have high economic importance to Indonesian society, which could be classified into several groups, as follows:

- a) For Currency Earnings: Oil palm, Rubber, Cacao, Coffee, Tea, Wood, Pulp and paper, Rattan, Fish and Mollusc, Seaweed, Pineapples, Herbs.
- b) For Domestic Needs: Paddy (Rice), Sugarcane, Soybean, Cassava, Corn, Cows (meat and milk), Buffalo, Sheep/Ram, Chicken, Ducks, Fresh Water Fish, Fruits and Vegetables.

On the other hand there are a couple of Materials sources for conversion technology, as follows:

- The Whole agricultural produce of harvest
- The by-products or wastes of agroindustrial conversion (chips, cuts, shredded, remnant, reject portions, off-odor, off-size, etc.)
- Could be in the forms of solid, liquid, and gaseous, or mixtures of all

I. ZERO WASTE TECHNOLOGY IN OIL PALM INDUSTRY: RECOMMENDATION FOR PALM OIL INDUSTRIAL CLUSTERS (POIC)

Oil palm industry in Indonesia has grown rapidly during the last decade. Palm oil is becoming a more important raw material for many products. Compared to other oil plants cultivated in Europe, palm oil has several advantages, such as remarkably higher annual oil yield and lower production costs. Palm oil is used in various food products, such as cooking and frying oils, margarine, frying fats, shortenings, vanaspati (vegetable ghee), non-dairy creamer, ice cream, cookies, crackers, cake mixes, icing, instant noodles, biscuits (Ministry of Industry, 2009). Palm oil is also used for non-food products important applications such as diesel, engine lubricants, base for cosmetics and related products (Butler, 2006). The palm oil downstream products are shown in Figure 1, while the added value increase presented in Table 1.

The principal activities of the oleo chemical sub segment are the manufacturing and sales of fatty acids, glycerin, soap noodles and fatty esters. These versatile products are used in a wide variety of applications, including manufacturing of detergents, surfactants, shampoo, soaps, cosmetics, pharmaceutical products, food additives and plastics. Today, palm oil is an important source for edible oils, as raw material for

cosmetics and detergents and more recently for biodiesel production (Wicke, 2008; de Vries, 2010, Lim, 2010).

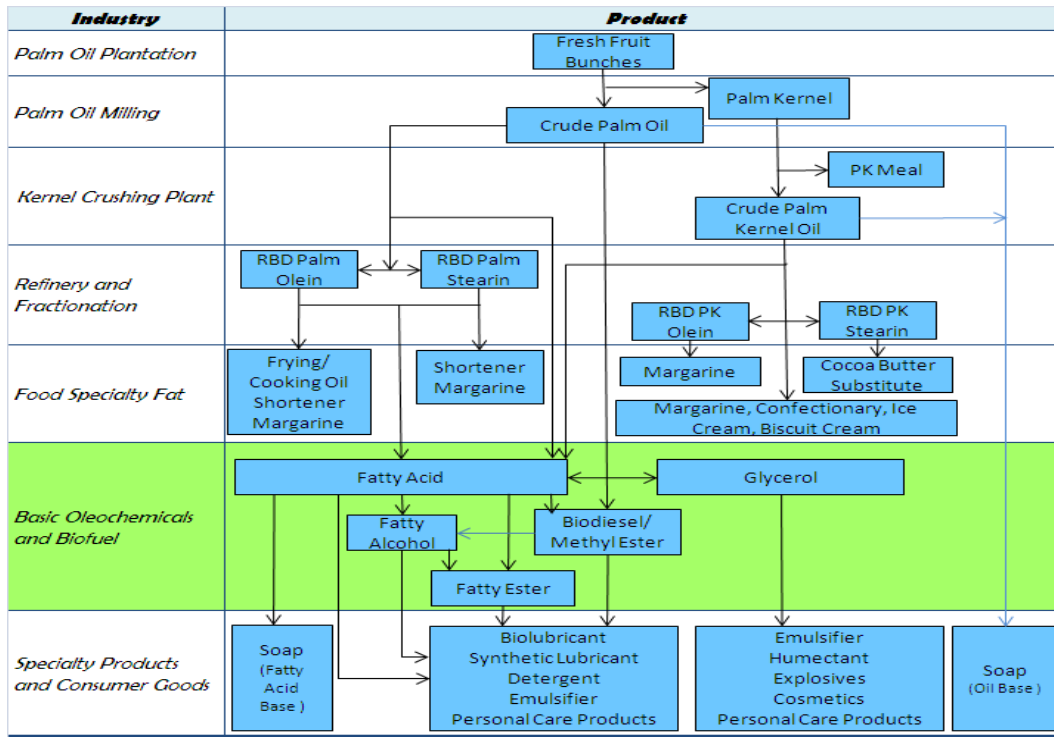

Figure 1. Palm Oil and Related Industries (Lie, 2013)

Table 1. The Increase in Added Value of The Downstream Products of Palm Oil

No	PRODUCTS	PRICE USD/ton	ADDED VALUE (CPO/CPKO)
1	CPO	1.168	0 % (basis)
2	CPKO	1.322	14%
3	Cooking Oil (packed/bulk)	1.575	35%
4	Margarine/Shortening	1.732	48%
5	Confectionaries *)	1.850	39%
6	Methyl Ester	2.123	82%
7	Fatty Acids	2.820	141%
8	Fatty Alcohol *)	4.200	217%
9	Surfactans	5.450	366%
10	Cosmetiks **)	8.230	522%

Price as per April 2012 calculation based on % mass with the conversion factor based on CPKO

**) Raw materials for Cosmetics. Ministry of Industry (2012).

1.1. The Raw Materials for Operating Industries in The Palm Oil Industrial Clusters.

Based on the report of Gumbira-Sa'id, *et al.*(2012), some materials to be used in palm oil industrial clusters are listed below.

- 1) Palm Oil Mill (75 tons FFB/h): Fresh Fruit Bunches of oil palm
- 2) PKO Plant (400 tons /day): Oil palm kernels
- 3) Feed Mill: Oil Palm leaves, cake etc.
- 4) Integrated Biodiesel Plant (600 000 tons/ year) and Phyto nutrients Plant: CPO
- 5) Oleochemistry (Fatty Alcohol) (90000 tons/ year): PKO
- 6) Refinery (Frying Oil) (600.000 tons/year): CPO
- 7) Electricity Power Plant: Oil Palm Based Solid materials
- 8) CPO Bunkers: CPO, Cooking oil etc.
- 9) Waste Water Treatment Plant and Methane Capture Facilities: Palm Oil Mill Effluents (POME)

There are at least eight types of industries (Table 2) that have been and will be operating in each palm oil industrial cluster, namely CPO Mill, PKO Plant, Feed Mill, Integrated Biodiesel Plant and Phyto nutrients Plant, Oleochemicals (Fatty Alcohol), Refinery (Frying Oil), Electricity Power Plant From Oil Palm Based Solid materials, CPO Bunkers, and Waste Water Treatment Plant and Methane Capture Facilities.

Furthermore, wastes from the palm oil industry lead to severe environmental problems in future and should be utilized as resources to develop bio-economy and market the carbon neutral products. The concept of eco industrial cluster will support the industrial players and the government as responsible actors in developing agroindustry. Some of the potential socio-impacts benefits from the establishment of palm oil industrial clusters are (i) job opportunities, (ii) clean and renewable energy, (iii) reduction in energy cost, (iv) Increase of Electricity Supply Coverage.

Table 2. The Type Of Industries to be Operated in The Three Palm Oil Industrial Clusters

POIC SEI MANGKEI (NORTH SUMATERA)	POIC DUMAI – PELINTUNG (RIAU)	POIC MALOY (EAST KALIMANTAN)
1) Palm Oil Mill (75 tons FFB/h)	(1) Palm Oil Mill (75 tons FFB/h)	1) Palm Oil Mill (75 tons FFB/h)
2) PKO Plant (400 tons /day)	(2) PKO Plant (400 tons/day)	2) PKO Plant (400 tons/day)
3) Feed Mill	(3) Biodiesel Plant	3) Biodiesel Plant
4) Small and Medium Scale Industries	(4) Refinery (Frying Oil)	4) Refinery (Frying Oil)
5) Integrated Biodiesel Plant (600 000 tons/ year) & Phyto nutrients Plant	(5) Methane capture facilities	5) Electricity Power Plant From Oil Palm Based Solid materials
6) Oleochemistry (Fatty Alcohol) (90000 tons/ year)	(6) Anorganic Fertilizer Plant	6) Biosurfactant Plant
7) Refinery (Frying Oil) (600.000 tons/year)	(7) Methyl Esther Distillation Plant	7) Soap and Cosmetics Plant
8) Electricity Power Plant From Oil Palm Based Solid materials	(8) Feed Mill	8) Fatty Acid Plant
9) CPO Bunkers	(9) Electricity Power Plant From Oil Palm Based Solid materials	9) Glycerine Purification Plant
10) Waste Water Treatment Plant and Methane Capture Facilities	(10) Spent Earth Extraction Plant	10) Margarine, Shortening, Red Frying Oil, and Ghee Manufacturing Plant.
	(11) Liquid Smoke Plant	11) CPO Bunkers.
	(12) CPO Bunkers.	

1.2. Palm Oil Biomass Utilization

In the palm oil value chain activities, there is 1 surplus of waste which has a high value benefits, especially in the case for empty fruit bunches (EFB) biomass utilization. On the other hand, fibre and kernel shells could also be used to produce steam and electricity for the boiler. The boiler ash and EFB could be returned as fertilizers in the plantation.

There are advantages in the use of biomass. Biomass is a renewable resource that has a steady and abundant supply, especially those biomass resources that are by-products of agricultural activity. As raw materials, biomass wastes have attractive potentials for large-scale industries and community-level enterprises. Furthermore with the global campaign to combat climate change, Indonesian oil palm industry are now looking for alternative sources of energy to minimize green house gas (GHG) emissions. Figure 2 shows the utilization of oil palm biomass proposed by The Indonesian Oil Palm Research Institute (2012).



Figure 2. The Utilization of Oil Palm Biomass
Source: IOPRI (2012); Gumbira-Sa'id (2013)

Composting is a viable means of transforming various organic wastes into products that can be used safely and beneficially as biofertilizers. Furthermore, oil palm mill generally can handle about 100 metric tonnes (mt) of fresh fruit bunches daily. At the mills where oil extraction takes place, solid residues and liquid wastes are generated. The solid residues, mainly empty fruit bunches (EFB), are more than 20% of the fresh fruit weight (Ma et al., 1993; Kamarudin et al., 1997). EFB is a common material used in composting. In general, composting was carried out using combinations of EFB and POME or manure. More than 500 kg (around 0.5 m³) of liquid wastes, mainly in the form of palm oil mill effluent (POME), are discharged during the processing of 1.0 mt of fresh fruit bunches (Ma et al., 1996). Composting of EFB has been extended to farmers by IOPRI. One of them is CV BinaTani Sejahtera. Figure 3 shows composting process EFB and figure 4 shows composting process by IOPRI.

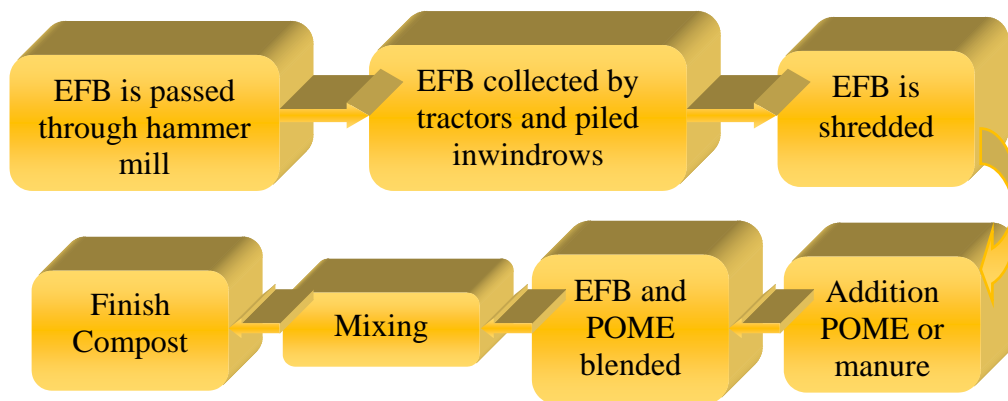

Figure 3. Composting Process (Hamdan et al., 1998).

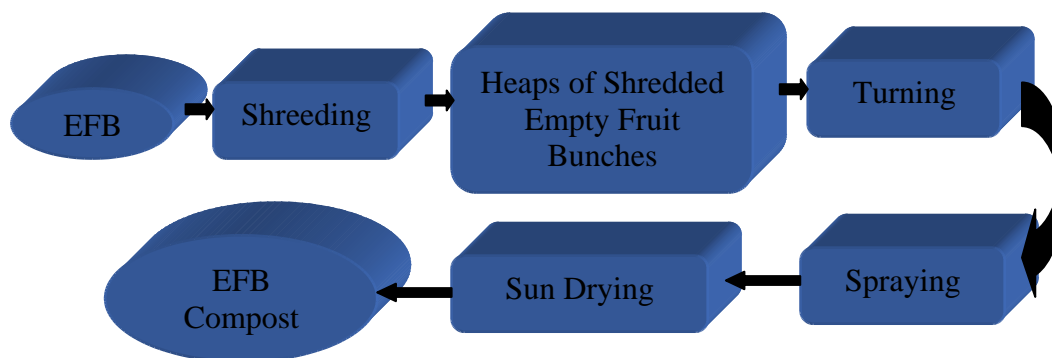

Figure 4. Compost Production Process by IOPRI (2012)

The pulp and paper industry preferred use of coniferous and deciduous trees for papermaking because their cellulose fibers in the pulp make durable paper. With improvements in pulp processing technology, fibers of almost any non-wood of plants species can be used for paper pulp. Substituting this lignocellulosic material can reduce the burden on forest while supporting the natural biodiversity (Singh, et al., 2013). Oil palm industries produce an enormous quantity of lignocellulosic biomass, such as oil palm frond (OPF), and oil palm trunks (OPT). OPF pruned when collecting the fruit bunches; the stalk part contains carbohydrates as well as lignocellulose. OPT Discarded for replantation after 25~30 years of the oil production. OPF and OPT as alternative source of cellulose based material to produce pulp and paper.

Particle board is an engineered material that can be classified as a composite panel. It has been widely utilized in many industrial and domestic applications for structural components in furniture or architecture, and it is in high demand as a building material (Nadhari, *et al.*, 2013). Manufacturing of flat particleboard from oil palm biomass was envisaged a long time ago. Oil palm trunk (OPT) has a high starch content (12,19-17,15%) and sugar content. Sugar content in OPT consists of glucose, xylose, and arabinose. OPT could probably help the self-bonding in binderless particleboard (Hashim et al., 2011). Research on the use of OPT in the manufacture of particle board

has been conducted by *Nadhari et al.* in 2013. Figure 4 shows Manufacture of particleboard from OPT.

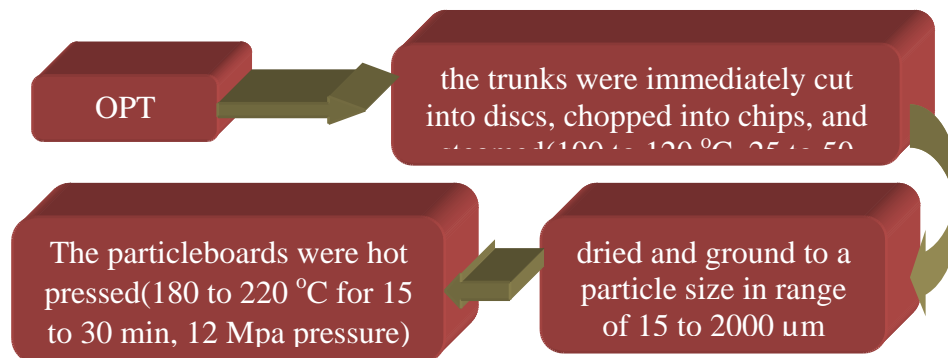

Figure 4. Manufacture of particleboards From OPT (Nadhari, et al., 2013)

1.3. Down-Stream Industries: The Reasons to Utilize Spent Bleaching Earth (SBE).

Bleaching earth is used to produce better quality of oil by removing colouring substances and trace elements in vegetable oil. Meanwhile, spent Bleaching Earth (SBE) is a solid waste material generated as a part of refining process in the vegetable oil industry. In Indonesia, bleaching earth is regenerated from palm oil refining industry. Furthermore, Indonesia is the biggest country as the palm oil producer. Rapid increase in global population has caused an increase in palm oil production; hence, spent bleaching earth (SBE) disposal problems constitute a significant economic waste and an environmental problem. SBE is potentially harmful to the environment due to off-odor and susceptible to fire-burning. On the other hand, bentonite is not renewable, so that its use has to be maximized. The management of SBE should use reduce, reuse, recycle and recovery.

The regeneration of SBE could be the solution to be eco-friendly technology or even cleaner production. Therefore, it becomes an advantage to use SBE which is abundant in its availability and easy to find at the single palm oil refinery. The regeneration of SBE must be preceded by eliminating residual oil contained in SBE. It can be done by performing the extraction process by utilizing the oil content as materials for biodiesel through *in situ* trans-esterification process. On the other hand, bleaching process leaves SBE which still contains residual palm oil by 20% by weight (AS Fahmi, 2013) or even 40% (Taylor 1999).

The utilization of oil contained in the spent earth has also been examined and developed not only in Indonesia but also in Malaysia. The utilization of residual oil in the SBE also meets the standards of economic viability (Alhamed and Al Zahrani, 1999). It shows that by the amount of oil recovered from SBE (based on 30% of oil absorbed in SBE): 36 000 t. Recovery of residual oil from SBE offers revenue of RM 90 million to the palm oil processing industry (Kheanget *all.*, 2007). The recovery process of residual oil is shown in the below (Figure 5).

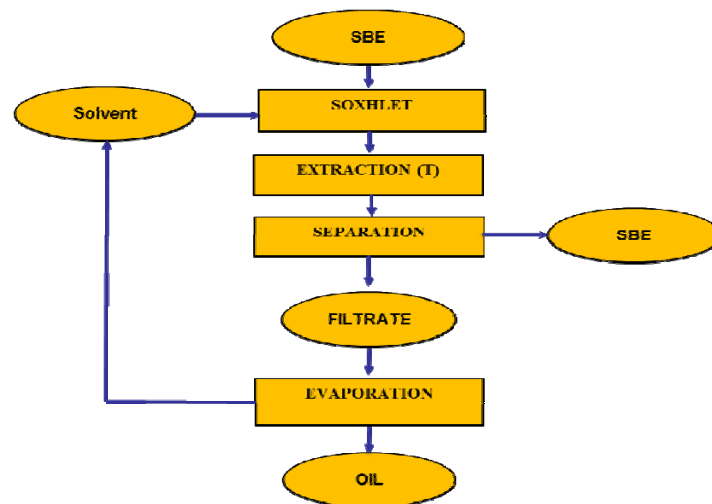

Figure 5. Process Recovery of Palm Oil Contained in SBE

On the other hand, utilization of the SBE residual oil can also be carried through *in situ* trans-esterification process, to produce biodiesel. The utilization of residual oil in spent bleaching earth into biodiesel is considered more efficient, due to most commercial biodiesels are produced from edible vegetable oils which are expensive. The competition for palm oil between food, feedstock for chemicals and biodiesel has put palm oil in the limelight and resulted in an extremely controversial debate around the world (de Vries, 2008; Verwer, 2008). By conducting *in situ* trans-esterification, the residual oil contained in SBE could be utilized as biodiesel without performing oil extraction. The flow process of biodiesel production by *in situ* trans-esterification is shown below (Figure 6)

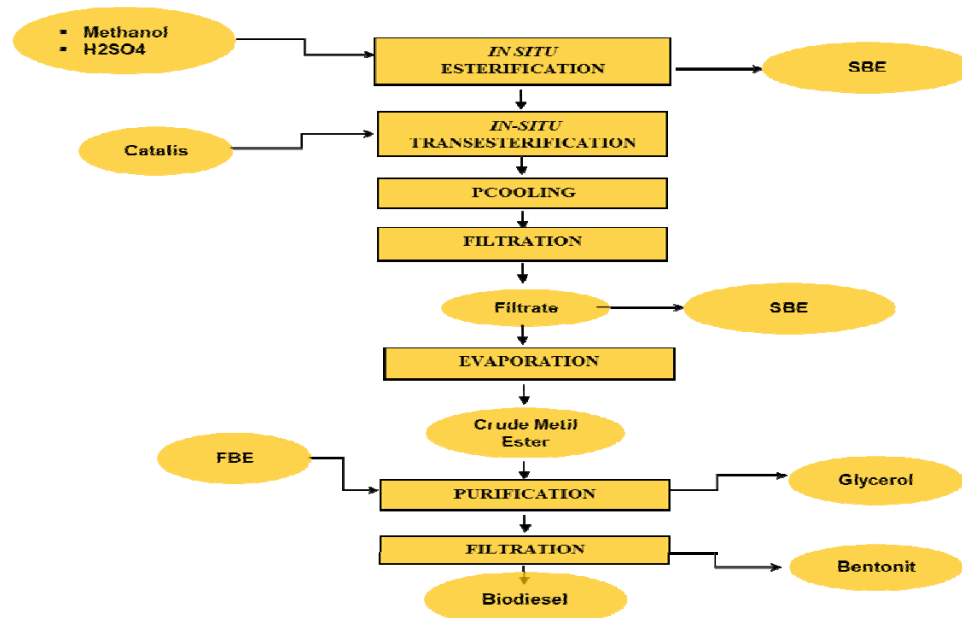

Figure 6. Biodiesel Production from Residual Oil Contained in SBE

The Application of SBE as an Adsorbent in Biodiesel Purification

The de oiled SBE regenerated from biodiesel production could be used as an adsorbent material which can be used not only in the refining process but also in the biodiesel purification. The de oiled spent bleaching earth may be reused in bleaching, either directly or after activation with acids (Alhamed and Zahrani, 2002). Activation is atreatment of the adsorbent aiming at enlarging the surface are a by breaking hydrocarbonbonds or oxidize the surface molecules, so that enlarging the surface area and the effect on the absorption. By activation process, SBE can be used as new adsorbent (fresh bleaching earth).

II. UTILIZATION OF POME: REDUCING GHG EMISSION AND CREATING ECONOMIC BENEFITS

Palm Oil processing gives rise to highly polluting waste-water, known as Palm Oil Mill Effluent (POME). POME is a wastewater generated by palm oil processing mills and consists of various suspended components. POME has a very high Biochemical Oxygen Demand (BOD) and Chemical Oxygen Demand (COD). Anaerobic digestion is widely adopted in the industry as a primary treatment for POME. It is not only used as a waste treatment process, but also produces a methane-rich biogas which can be used to generate heat and/or electricity. Figure 7 shows flow process of POME handling. The process of anaerobic digestion consists of three step. They are hydrolysis, conversion of decomposed matter to organic acids (acidogenesis), and acids are converted to methane gas (methanogenesis). Figure 8 shows the mechanism of anaerobic fermentation process.

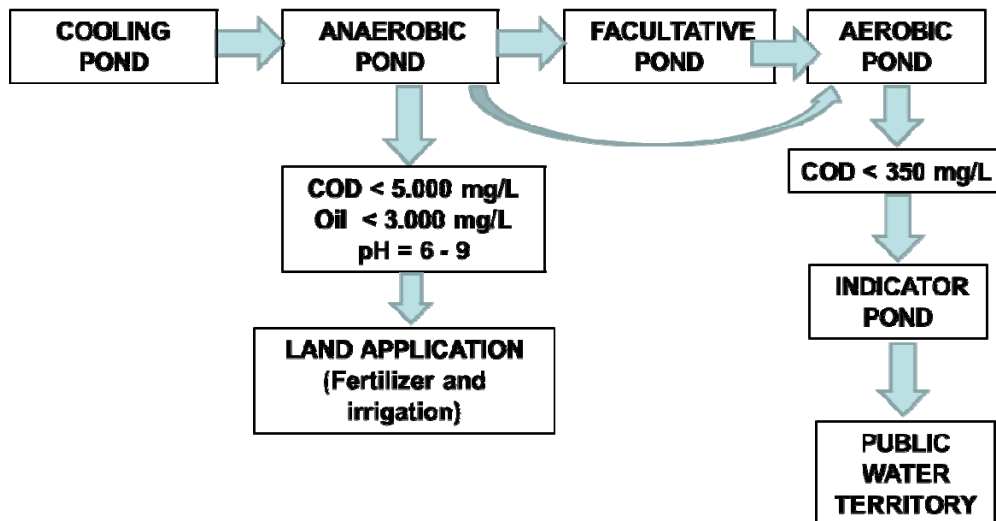

Figure 7. The Flow Process of Pome Handling

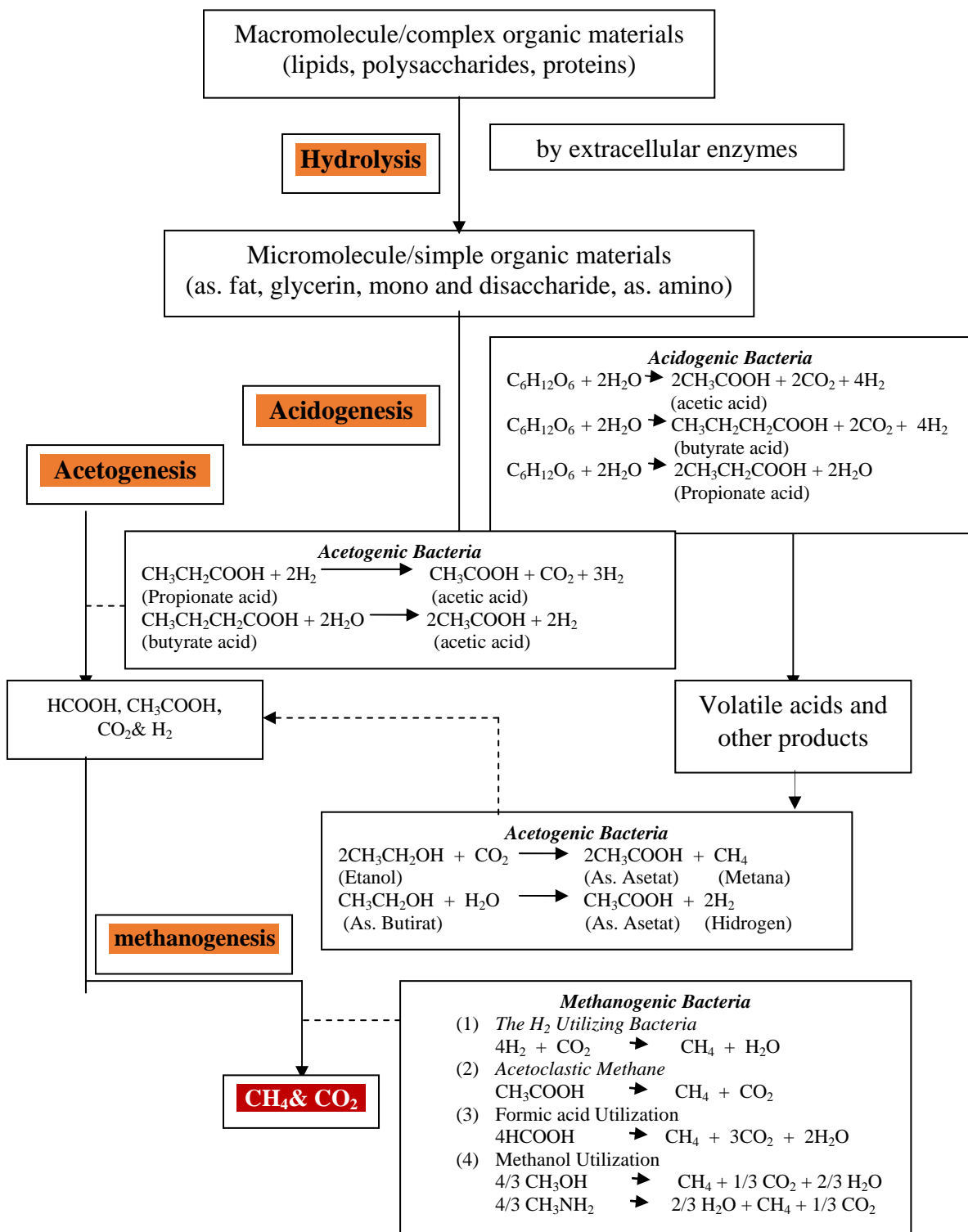

Figure 8. The Mechanism of Anaerobic Fermentation Process
(Grady and Lim, 1980)

 BIOGAS 	
• Normal	: 55-70% CH ₄
• For Energy	: ≥ 85% CH ₄ (Kapdi et al. 2004)
 ENERGY IN 1 m³ BIOGAS 	
• Electricity	: 2,0 kWh
• Thermal	: 3,2 kWh (Sist 1994 in Gumbira-Sa'id 1994)
 CONVERSION MACHINERIES 	
• Gas engine	
• Gas turbine (Heat & Power co-generation)	
• Microturbine	
• Fuel cell	(Khanal 2008)

Tabel 3. Biogas energy conversion

1 m ³ of biogas energy	Utilization
comparable to the light 60-100 W for 6 hours	Lighting*
comparable to 1.25 kwh electricity	Electricity*
0,62 liter	Fuel Substitute**
0,52 liter	Kerosen
	Solar

Source: *) Kristoferson and Bolkaders (1991) in Haryati (2006)

***) Ditgen PPHP Departement of Agriculture RI (2009)

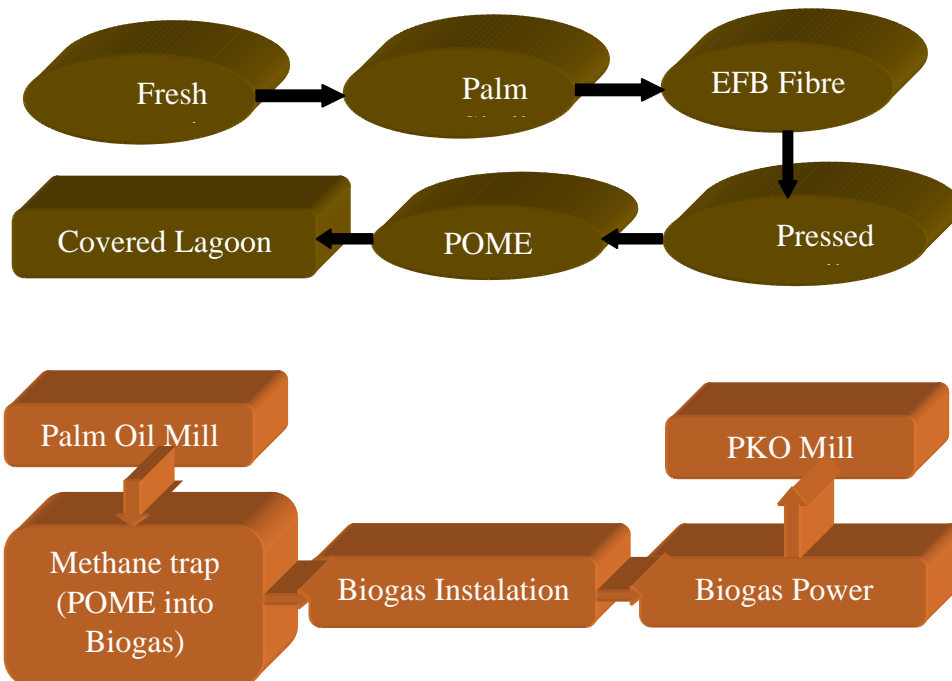

Figure 10. The Flow Process to Utilize Biogas for Power Plant in Tandun.

ACKNOWLEDGEMENTS

The authors would like to thank:

1. Directorate General of Higher Education, Ministry of Education and Culture, The Republic of Indonesia for financial assistance through Pemprinas MP3EI Year 2013 (Study of The Readiness of Palm Oil Industrial Clusters in Achieving The Mission of MP3EI).
2. Directorate General of Agro-Industry Ministry of Industry and The Working Groups of Palm Oil Industrial Clusters in North Sumatera, Riau and East Kalimantan Provinces for data, Information and consultancy.

REFERENCES

- de Vries, S. C. (2008). "The bio-fuel debate and fossil energy use in palm oil production: a critique of Reijnders and Huijbregts 2007." *Journal of Cleaner Production* 16(17): 1926-1927.
- Ditgen PPHP DepartemenPertanian RI. 2009. Biogas SkalaRumahTangga, Program Bio EnergiPedesaan (BEP). Direktorat Pengolahan Hasil Pertanian-Ditjen PPHP DepartemanPertanian RI. Jakarta.
- Grady Jr. C.P.L. and Lim H.C. 1980. *Biological Wastewater Treatment, Theory and Applications*. Marcel Dekker Inc. New York.
- Haryati, T. 2006. Biogas: LimbahPeternakan Yang MenjadiSumberEnergiAlternatif. *Wartazoa*. 16 (3): 160-169.
- Hashim, R., Wan Noor Aidawati Wan Nadhari, Othman Sulaiman, Fumio Kawamura, SalimHiziroglu, Masatoshi Sato, Tomoko Sugimoto, Tay Guan Seng, Ryohei Tanaka. 2011. Characterization of Raw Materials and Manufactured Binderless Particleboard from Oil Palm Biomass. *Elsevier Volume 32, Issue 1, January 2011, Pages 246–254*.
- Kamarudin H, Mohamad H, Arifin D, Johari S. 1997. An Estimated Availability of Oil Palm Biomass in Malaysia. *PORIM Occ. Paper Palm Oil Res. Inst. Malaysia*.
- Ma AN, Cheah SA, Chow MC (1993). Current status of palm oilprocessing waste management. In: *Waste Managaement inMalaysia: Current Status and Prospects for Bioremediation*. YeohB.G. et al. (Eds.), pp. 111-136.
- Nadhari, WNAW.,Hashim, R., Sulaiman, O., Sato, M., Sugimoto, T., Selamat, M.E. 2013. Utilization of Oil Plam Trunk Waste for Manufacturing of Binderless Particle board:Optimization Study. *BioResources* 8(2), 1675-1696
- Pahan, I., Gumbira-Sa'id, E., Tambunan, M., Asmono, D., Suroso, A.I. (2011). The future of palm oil industrial cluster of Riau Region-Indonesia. *European Journal of Social Sciences*, 24 (3), pp.421-431.
- Singh Pooja, Othman Sulaiman, Rokiah Hashim, Leh Cheu Peng, Rajeev Pratap Singh. 2013. Using Biomass Residues From Oil Palm Industry As a Raw Material For Pulp and Paper Industry: Potential Benefits and Threat To The Environment. *Environment, Development and Sustainability*. Springer. April 2013, Volume 15, Issue 2, pp 367-383

- Tan, KT, Lee, KT, Mohamed, AR and Bhatia, S (2009) Palm oil: Addressing issues and towards sustainable development. *Renewable and Sustainable Energy Reviews* 13(2):420-427.
- Verwer, C; van der Meer, P.; Nabuurs, G.-J. (2008). Review of carbon flux estimates and other GHG emissions from oil palm cultivation on Tropical peatlands. Wageningen, Alterra Wageningen.

INTEGRATED SUGAR INDUSTRY: MAXIMIZING ENERGY UTILIZATION OF THE CANE

Nur Iswanto

ISSCT Councillor, Jl. Jembatan Merah No. 3 – 11, Surabaya, Indonesia

* nur_iswanto@yahoo.com

ABSTRACT

The main goals of the paper is to presenting the energy potency of sugar cane both in terms of utilization of its fiber to produce power or use its constituent 'sugar' as an important energy food and also as source of feedstock to produce ethanol. In many major sugar-producing countries, like Brazil, India, and Thailand, sugar mills contribute significantly into national electric power supply through cogeneration projects. In implementing the projects, energy consumption of the mill should be reduced, and power generation to be maximized. Technology and equipment to achieve these objectives are presented. Due to depletion in fossil fuel reserve and rising in fuel price, utilization of fuel-grade bioethanol has become current topic worldwide. Some countries has setup mandatory program to blend ethanol with gasoline for transportation purpose. With lower production cost compared to ethanol from other feedstock, ethanol from molasses has gone through different routes. It is now common that cane juice is directly converted into ethanol. Ethanol distilleries also offered additional advantageous. Spent wash can be utilized as liquid or solid fertilizer, and in the same time to produce electricity via anaerobic bio-digesting and gas engine. In the green field projects worldwide, new sugar industry complexes incorporate sugar mill, cogeneration plant, and ethanol distillery. These improve economic viability of the project significantly. The concept also will be implemented immediately in Indonesia.

Keywords: sugar, cane, cogeneration, ethanol, energy.

INTRODUCTION

Sugar is well known for its importance as food, sweetener, and medicine for mankind. History tells us that by A.D. 500, sugar crystals were produced in India, and sugar crystallization from cane as the secret science has spread to Persia and other regions since after. Sugar industry has been a traditional industry and in many countries like Indonesia, was setup during the second half of the 19th century. And this particularly is relevant in respect to tropical countries/regions that are having plenty of sun shine and adequate rainfall. However, apparently sugar industry has the potential to be the industry of the future as well. Sugar cane crop offers the best way of harnessing solar energy and converts the energy into sugars and cellulosic components, known as fiber.

The rising prices of fossil fuels such as crude oil, natural gas, and coal, and depletion in their reserves, have been major concerns around the world. The widening gap between energy demand and source of energy, particularly, are major cause of worry for the future. The steady reductions in non-renewable sources of energy, and also

environment concern have added to importance in intensifying effort to find and to utilize green energy, including biomass and biofuel like ethanol.

Since several years ago, sugar industry in countries like Brazil, Reunion Island, Mauritius, India, and Australia has taken lead to produce not only sugar, but energy as well. Each ton of sugar cane (dry basis) has the similar energy content with 1.2 barrels crude oil (Kent, 2010), both in terms of utilization of its fiber to produce power or use its constituent sugars as an important energy food and also as raw material to produce ethanol. And therefore, sugar cane could also be called as 'Energy Cane', or in more popular term in Brazil as 'Sucro Energia'.

A. Sugar Manufacturing

In sugar mill, the incoming cane is crushed to extract the juice that contains sugars as well as non-sugars (impurities) in milling tandem or diffuser. Typically, sugar cane contains 70% juice. The mixed juice is then clarified to remove its non-sucrose components, mostly inorganic materials, by applying heat and milk of lime. These non-sucrose components are removed as filter cake. The clarified juice is evaporated to reach solid concentration near saturated point in multiple effect evaporators to obtain syrup. Crystallization process of syrup occurs in heated pans by removing the remaining water under vacuum condition. Masecuite, which is coming out from vacuum pan, is sent to centrifugal to separate sugar crystals from molasses. Molasses is utilized as feedstock to manufacture fuel grade or industrial grade ethanol in distillery. Other down stream products could also be derived from molasses or ethanol, like mono sodium glutamate, lysine, and acetic acid.

Generally, sugar mill produces either direct consumption sugar (plantation white sugar) or raw sugar. The latest one shall go into further step, which is refining process, to produce refined sugar. Countries like Brazil, India, and Thailand produce plantation white sugar, raw sugar, and refined sugar as well. While Australia only manufacture raw sugar and refined sugar.

The remaining fibrous material from extraction process of approximately 30% cane, called bagasse, is transferred to boiler and used as fuel to generate steam. Live steam is expanded in Turbo – Alternator unit to generate electric power to meet energy requirement in sugar mill operation. Exhaust steam (back pressure) that near its saturated temperature is employed as heating medium in heat exchanger units, such as juice heater, evaporator, and vacuum pan. The cycle of generating power and then heating sources is generally referred as cogeneration. In term of energy sufficiency, sugar industry is one of few industries that its feedstock also containing fuel (bagasse) to meet its energy demands. In addition, sugar cane bagasse could also be employed as raw material in manufacturing other products like, pulp, paper, and particleboard.

Thus, there is a wide range of co-products or down streams from sugar cane, particularly those derived from bagasse and molasses. The two are worldwide reach excellent economic viability, which are generating electric power from bagasse and producing fuel-grade ethanol from molasses.

B. Cogeneration In Sugar Mill

The level of energy demand in sugar mill operation is generally measured by the quantity of steam consumption per ton of cane crushed. The typical figure of energy consumption in Indonesian sugar industry, in Java particularly, is approximately 550 - 600 kg steam/ton cane, or steam % cane is 55 - 60%. This number is achieved in mill that employs single stage steam turbines as main primary drives in milling tandem, pumps and blowers/compressors. From experience, the figure could be much higher for the small and old mills that are operating steam engines.

Initially, saving bagasse and steam in sugar mill had not been economically attractive. Excess steam has been blown or vented to atmosphere, and surplus bagasse was problem, in particular when space and facilities for storage are the issue. Even though sugar mills could sell bagasse, the price however is not appealing. In Indonesia, we have witnessed 'mountains of bagasse' exist in some sugar mills in Lampung.

The situation has turned to be more conducive when the price of electric power increased to US\$ 70/MWh in countries like Brazil and India, where hydrocarbon fuel unable to meet national energy demand. Selling electric power to national grid or directly to end consumers will be generating decent income for sugar industry. This situation helps in country like India where sugar price is tightly controlled by government, and cane price is more political agenda than economic issue. Diversifying their business by also selling electric power helps sugar mills to survive and become more profitable. In addition, carbon-trading scheme under Kyoto Protocol provides additional incentive.

Brazil, India, Australia, Thailand, Mauritius, Reunion Island, Columbia, and some other major sugar producing countries had embarked the program to generate and export electric power from sugar industry, namely cogeneration projects. These countries have successfully setup a large number of such facilities with the latest technology in the last 10 years. In 2007/2008 Brazil produced 1,800 MW from its sugar industry, and targeted to generate 14,400 MW in 2020/2021 from sugar mills (Oliverio and Ferreira, 2010). In 2009, it was reported that the total installed cogeneration capacity of sugar mills in India was 1,280 MW. This capacity has the potency to increase to 10,500 MW, from which up to more than 6000 MW of exportable surplus (Avram-Waganoff *et al.*, 2010)

From technology point of view, maximizing power generation and saving process steam enable sugar mill to export its excess power of 100 – 125 kWh/ton cane (Morgenroth and Pfau, 2010). In order to achieve this objective, the steam consumption should be minimized, and the authors also suggested steam % cane in the range of 26 – 32 % as the benchmark for modern sugar mills. For a sugar mill with crushing capacity of 12,000 tones cane per day (TCD), or 500 tons cane per hour (TCH) for instance, the potential electric power to export is 50 – 62.5 MW/hour. With sufficient bagasse or other fuels to operate in 300 days/year (160 to 200 days during crushing season, and 100 to 140 days during off season), the mill has potency to sell electric power of 360,000 MWh – 450,000 MWh/year, or 360 – 450 GWh/year.

To accomplish these objectives, well-designed new mill in green field project or well-planned up-gradation program of the existing mills shall be carried out, which are including:

1. Maximizing power generation

Up to present time, most of sugar mills in Indonesia employ low-pressure boilers to generate steam, and expand the steam in back pressure turbo-generators to produce electricity. Low efficiency steam drives, such as single stage steam turbines are also under operation. The typical boiler pressure is 20 – 25 Bar, with the absent in heat recovery systems such as pre-heater, economizer, and superheater. In these situations, the quantity of bagasse consumption as fuel in boiler is high, and steam consumption is also high. The average steam rate of 12 tons steam/MWh is usually recorded by backpressure turbogenerators, and 20 tons steam/MWh is the typical rate for single stage steam turbine.

However, it is also common to find colonial era fire-tube boilers and steam engines in many mills in Java. These old fashioned and inefficient fire-tube boilers produce steam with pressure of 5 – 7 Bars. The typical steam consumption of steam engine is much more than 20 tons/MWh. Unsurprisingly, this situation leads to fuel deficit in sugar mill operation.

Now days, the new constructed sugar mills and brown field cogeneration projects worldwide are moving toward higher-pressure boilers. Boilers with pressure of 65 Bar, 87 Bar, or even 105/110 Bar with steam temperature of 540 °C are now available in the market. These boilers could be supplied by some major EPC contractors, like ISGEC (India) and Dedini (Brazil). In addition, extraction-cum-condensing steam turbines with steam rate of less than 4 tons/MWh are also available. The combination of these higher-pressure-higher temperature boilers and condensing-extraction turbines improves thermodynamic cycle efficiency in sugar mill operation. From thermodynamic point of view, in Rankine cycle particularly, better efficiency is achieved with the higher temperature of steam. As the results, more power could be produced with the same quantity of steam, which in many cases at least 3 times larger.

It was reported in ISSCT Co-products Workshop held in Coimbatore (India) in 2009, for instance, fully electrified sugar mill with 65 Bar steam boiler and extraction condensing turbine, capable to export 112 kWh/ton cane crushed. And with 110 Bar boiler, the excess power to export to grid could be more than 125 kWh/ton cane (Avram-Waganoff *et al.*, 2010). Subarmanian and Awasthi (2010) presented a table to compare the benefits of employing high- pressure boilers, which are including:

- a. Higher steam/fuel ratio.
- b. Lower specific steam consumption.
- c. Higher power generated per ton of bagasse.

Better and more efficient thermodynamic cycle in sugar mill operation causes improvement in power generating from available bagasse, and saving bagasse as well. However, like other power-generating project, one of main key success factor for cogeneration in sugar mill is the quality and availability of fuel. Bagasse quality is associated with its caloric value, which has negative relationship with moisture content and residual sugar content in bagasse. Good extraction in milling tandem or diffuser could produce good quality bagasse with moisture content of less than 49% and thus caloric value of more than 2,000 kCal/kg. This bagasse may generate steam between 2.0 to 2.2 tones steam/ton bagasse.

Depends on its fiber content, typical bagasse quantity produced in sugar mill is approximately 26 to 34% cane. Cane trash, including cane top and cane leaves, is also considered as valuable source of additional fuel for boiler. Several boilers manufactures design combined-fuel or multi-firing capacity of furnace to allow boilers utilizing other biomasses, like wood dust, straw, rice husk, or even coal and gases. This obviously ensures the power plant/cogeneration to operate and produce electricity in year round with higher power output, in particular during off-season. Higher power output during off-season is obtained since no captive power is required to run sugar mill.

The new direction that sugar cane to become 'energy cane' has modified the way to evaluate sugar cane quality. Corcodel and Roussel (2010) suggested that cane energy content and energy yield per hectare or per tone of cane, are now major parameters in Reunion Island. The authors also reported that Reunion Island sugar industry has been developing new varieties of sugar cane that containing high sugar and high fiber as well.

In addition, cane trash also offers the benefits as biofuel. Before, pre-harvesting as well as post-harvesting burnings are common practices in sugar industry. With its high potential energy content, cane trash increases the value of cane crop against other crops. Kurt Woytuik (2006) reported that dry-basis cane trash has caloric value of 3845–4375 kcal/kg. Burning cane trash (burnt cane) releases harmful greenhouse gases like N₂O, CH₄ and CO₂ in addition to CO. Under cogeneration program, green cane harvesting is now a common practice worldwide.

2. Saving energy and steam consumptions

Minimizing energy consumption during sugar mill operation is the same importance with maximizing power generation from bagasse in cogeneration program. Some authors, such as Oliviero and Fereira (2010), and Morgenroth and Pfau (2010), and Kent (2010) have suggested technology and equipment to employ in reducing energy consumption as well as in maximizing energy conservation. To sum up, these authors suggested the following:

- a. Diffuser plus dewatering mills or 6-mill tandem.
- b. Direct contact juice heaters with vapour.
- c. Falling film tubular evaporator.
- d. Five or six effect evaporators.
- e. Vapour bleeding from all effects of evaporators.
- f. All vacuum pans heated with vapour from evaporators, not exhaust steam.
- g. Maximise heat recovery from condensate.
- h. Utilise flash vapour as heating medium.
- i. High G-factor of continuous centrifugal.
- j. High-level process automation.

In order to decrease heat inputs in steam generating, Subarmanian and Awasthi (2010) suggested installing high pressure feed water heaters using bleed steam from turbine to increase feed water temperature to approximately 220 °C before entering economizer. Significant advantages could also be achieved in reducing auxiliary power consumption by using variable frequency electric drives in boiler as well other parts of sugar mill. In

addition, minimizing the use of exhaust steam as heating medium via heat recovery system means more live steam could have gone through condensing route, instead of backpressure, to generate more power in extraction cum condensing steam turbine. Thus steam consumption of less than 30% cane and excess electric power of 125 kWh/ton cane could be achieved.

C. Production Of Fuel Grade Ethanol

Due to the Oil Crisis in 1973, and the rising in fuel cost as the consequence, in 1975 Government of Brazil established the National Alcohol Program, called the Proalcool (Programa Nacional do Álcool). The intention of the program is to incorporate ethanol into Brazilian Energy Matrix, especially in transportation by blending ethanol with gasoline, or further by replacing gasoline (Oliverio and Boscariol, 2013). Now days, 90% of total cars produced in the country are flexi fuel cars, which can use 100% gasoline, blended gasoline and ethanol, and 100% ethanol as the fuel.

Proalcool program is considered as the most significant renewable energy program in the world for substitution of fossil fuels with biofuels, created a steady demand and established the needs for its use, particularly in transportation sector. With government support, private investment and then competitive production, the program led to better sustainability in the sugarcane industry.

Many countries now have introduced mandatory program to blend ethanol and gasoline. India, Thailand, Singapore, and Australia, for instance, have introduced E 10 fuel for cars, which is blending 10% of ethanol and 90% of gasoline.

In addition, the cost in fuel grade ethanol production from molasses is much cheaper than from other feedstocks, like corn and cassava. Brazilian sugar industry produces ethanol with half cost of the ethanol cost from corn (Avram-Waganoff *et al.*, 2010). The authors pointed out that this cost advantageous is due to higher productivity of ethanol/hectare, which are 6,000 L/Ha for cane-based ethanol, and 3,000 L/Ha for ethanol from corn. For country like Indonesia, employing feedstock likes corn and cassava will raise concern in food security.

With further rising fuel costs and demand for fossil fuel, Brazilian sugar industry is moving toward to new concept in production ethanol. Previously, sugar mill had only one product, which was sugar, and then distillery was integrated. Molasses was solely raw material in manufacturing ethanol. However, now days, many of sugar mills in Brazil are also pumping cane juice to the adjacent distillery. More portion of cane juice is converted into ethanol when ethanol price increases. And in the near future, Brazilian sugar industry will be converting a major portion of its sugar cane crop into ethanol (Oliverio and Boscariol, 2013). Generally, 10 L ethanol/ton cane is produced via molasses, and 75 – 80 L/ton cane could be manufactured if cane juice is directly used as raw material. In term of processing wise, it is easier to produce ethanol via direct fermentation of molasses or cane juice.

Manufacturing ethanol directly from cane juice is now also a common practice. During the Pre-Congress Tour prior to ISSCT Congress XXVII (2010), in Veracruz, Mexico, the participants were touring to a distillery which has capacity of 100 kL/Day. During the visit, molasses was the raw material. But on site, a mill tandem, boiler and powerhouse were under construction. In the new concept, the mill will crush incoming

sugar cane, and the extracted cane juice would be sent directly to distillery. As usual, bagasse would be fuel for the boiler. Oliverio and Boscariol (2013) presented that the new generation of mill in Brazil, like the Água Emendada Mill in Goiás (Brazil) will focus on production bioethanol and bioelectricity from cane, no longer sugar.

D. Other Potency From Ethanol Distillery

In ethanol manufacturing, however, environmental issue is very critical and sensitive, in particular regarding to the liquid waste, which is generally called spent wash or vinasse. A typical 10:1 ratio of vinasse to ethanol is common, which means for an ethanol distillery of 100 kL/day, the volume of vinasse produced could be about 1,000 m³/day or even more. This dark coloured liquid with high concentration of solid will release stinking gases after a few days of aerobic fermentation process in open and ambient conditions. These characteristics of vinasse obviously will never meet any environment standard and regulation.

Apparently, in addition to its organic compound, this spent wash still contains a significant quantity of inorganics like potassium, nitrogen, and phosphate. These compounds are previously added to molasses as nutrients for the yeast that converts sugars into ethanol. And it turns out that these inorganics are macronutrients for cane crop as well. In countries like Brazil and Australia, spent wash (vinasse, stillage or called dunder in Australia) is applied directly as liquid fertilizer to soil.

In India and Thailand, the new technology is applied, and vinasse is gone through anaerobic bio-digesting process. The remaining organic compounds of vinasse are converted into methane gas. This gas is then utilized as fuel in gas engine to generate electricity. The installation can be seen for instance in Korat Industry, Thailand, and some vendors, like Praj Industries Ltd., and Global Water Engineering, could supply the technology. For the typical 100 kL/D ethanol distillery, the methane gas obtained from anaerobic bio-digesting facility capable to generate 4 MW electric powers via combustion process in gas engine. This is more than enough to supply the captive power required to run the distillery and its supporting facilities. Manufacturers like Jenbacher (GE) could provide the gas engine.

The less harmful remaining liquid can be applied directly as liquid fertilizer or mixed with filter cake and fly ash (from boiler) prior to be utilized as solid fertilizer or bio-composting. Through the latest method, macronutrients as well as compost can be input to soil. This can be done since sugar mill typically produced filter cake and fly ash 4-4.5 % cane and 1.5% cane, respectively.

E. Model For Integrated Sugar Industry

The world sugar price have been very volatile in the last few years and therefore for a sustainable operations it is extremely relevant now to set up integrated sugar cluster in such that it is possible to earn excellent return on capital investment. Now, the new green field projects worldwide adopt the integration concept with zero discharge, that incorporating ethanol distillery and cogeneration project into sugar mill. With only one platform, the integrated sugar complex could produce sugar, power, ethanol, liquid and solid fertilizers.

PT. Perkebunan Nusantara X (Persero) is one of state owned enterprises in sugar business in Indonesia. The company is now developing a plan to construct integrated sugar cluster in Madura Island. The implementation program has been setup to develop at least 12,000 Ha cane crop area, 1 sugar mill with the capacity of 5,000 TCD, expandable to 7,500 TCD, 30 MW cogeneration plant, and a 60 KLPD ethanol distillery integrated with anaerobic bio-digesting and gas engine facility to produce electricity, liquid fertilizer and solid fertilizer. Under internal study, this integrated model improves significantly the economic viability of the project. Furthermore, one platform that simultaneously produces sugar, electric power, ethanol, and vinasse that replacing chemical fertilizers, will indeed guarantee better sustainability of the industry, both commercially and environmentally as well.

CONCLUSION

In recent years, sugar industry has been transforming from traditional and old industry into future industry.

With depletion in fossil fuels reserve and increasing demands for renewable bioenergy, the sugar industry offers solution via ethanol from molasses and cane juice, and bioelectricity from bagasse.

Transforming the industry into 'sucro-energy' by maximizing energy utilization of sugar cane, also improves economic viability and environmental sustainability of the industry.

Integrated sugar complexes are now implemented for green sugar mill projects worldwide. And Indonesian sugar industry is moving toward to embrace the trend.

ACKNOWLEDGEMENT

The author would like to express sincere gratitude to Mr. Jeewan Jyoti Bhagat, the former President of Sugar Technology Association of India (STAI), and currently the Managing Director of Sugar Technology Mission Project Limited (STMPL), India, for inputs and discussion during the preparation of this paper.

REFERENCES

- Avram-Waganoff, P., Inkson, M.B., and Lavarack, B. P. 2010. "Report: ISSCT Co-products workshop 2009.
- Corcodel, L., Roussel, C. 2010. 'Energy content: a new approach to cane evaluation, ISSCT Conference 2010
- Kent, G.A. 2010. 'Design, manufacturing and maintenance of sugar mill equipment: ISSCT engineering workshop 2008 summary report, ISSCT Conference 2010
- Morgenroth, B., and Pfau, S. 2010. 'Factory concepts for very low steam demand and status of implementation, ISSCT Conference 2010

- Oliverio, J.L., and Ferreira, F.M. 2010. 'Cogeneration – a new source of income for sugar and ethanol mills or bioelectricity – a new business, ISSCT Conference 2010.
- Oliverio, J.L., and Boscarol, F.C. 2013. 'Expansion of the sucro-energy industry and the new greenfield projects in Brazil from the view of the equipment industry' ISSCT Conference 2013
- Subarmanian, A.K., and Awasthi, S. 2010. 'High pressure multi fuel fired boilers for co-generation' ISSCT Conference 2010
- Woytiuk, K. 2006. Sugar cane trash processing for heat and power production. Masters thesis, Lulea University of Technology, Available from:
<http://epubl.ltu.se/1653-0187/2006/57/LTU-PB-EX-0657-SE.pdf>

ECONOMIC PERSPECTIVE OF SUSTAINABLE AGRO INDUSTRY

Wijitapure Wimalaratana

Department of Economics, University of Colombo

INTRODUCTION

Any economy, as a long standing tradition, is divided into three major sectors as agriculture, industry and services. Historical evidences suggest that the economic development in many countries started with the high performance of agriculture and later on turned to industry and finally ended up with services. The relative importance of these three sectors shifts from agriculture through industry and services along with the economic development and this transformation is described as a structural change of a society. The importance of human settlements (dwelling patterns) shift from agro based rural areas to industry and services based urban centers along with this transformation. The sources of income and employment as well as government revenue, international transactions, social wellbeing of a society depend on the performance of these three sectors. The level of Gross Domestic Product (GDP) and economic growth, widely used two economic indicators of the modern world, reflect the performance of agriculture, industry, and services of a country.

Agro industry has evolved from primitive practices in the olden days to the modern automated systems over long period of time of the human history. Scale of production as well as the specialization of product has changed in the past along with the expansion of the market, advancement of the technology and evolution of the organizational pattern. The natural factors maintained the sustainability of the agro industry like many other human activities in the olden days as the human being had an extremely limited capacity to go beyond the laws of the nature. The man has managed to break the upper limit of the production imposed by the nature along with technological advancement. The scarcity of agricultural products has been replaced by abundance, access security has taken the place access insecurity, and the sameness of products has been replaced by variety even though there are disparities in geographical distribution of these changes.

A. Agriculture

The scope of agriculture encompasses through farming, livestock, poultry, fishing, hunting and forestry. Similarly, the area covered by agricultural products varies from foods and beverages for human consumption to fodder, fiber and other industrial inputs, landscaping, and aesthetic appealing of the forest and countryside. The quantity, quality and continuity of supply of these products are decided by natural diversity and human dexterity. The availability and accessibility of all products have improved with the advancement of the human civilization in the past, so that the local production is not a critical factor for food security, if sufficient income is generated from other sectors of the economy.

A few key historical turning points are taken into account when the development path of agricultural sector is examined. The Neolithic revolution in some 10,000 to 5000 years ago paved the way for permanent human settlements with the domestication of animals and plants instead of nomadic life and depending on forests for hunting, harvesting and other sort of food gathering (Weisdorf 2005). Under the medieval green revolution, Arabic and other Muslim traders diffused new crops and cultivation techniques, mainly within their trading areas, during 8th to 12th centuries. This practice raised the agricultural production and diversity while improving the living standards of people to some extent (Idrisi 2005). Western agricultural revolution during 15th to 19th centuries, increased the farm size, introduced new cultivation methods, new inputs including fertilizer and manures, new seeds and breeds, commercial cultivation, modern farm management, and agro based industries (Apostolides et al 2008). The green revolution in between late 1940s and early 1970s raised the agricultural productivity and production as a result of high yielding seed varieties, new agricultural inputs like fertilizers and mechanization of the production process (Gaud 1968). It was the most successful achievement against the world hunger even though there were some weaknesses, especially in the sphere of environmental degradation. The growing production owing to these changes created more opportunities for agro based industries than ever before. Since 1990s the world agriculture is experiencing the impact of biotech revolution; genetically modified crops are being cultivated as a result of this revolution. Under biotech revolution, new crops immune to diseases, pests, hostile weather conditions are being introduced while certain crops carry special nutrients and pharmaceutical agents (Committee on Agriculture 2012).

B. Agro industry

Industries are broadly classified into two on the bases of raw material sources as agro based and mineral based industries. Industry connected with agricultural raw materials is basically considered as the agro industry. Agro based industry is once again divided into two as food and non food industries. Agro industry transforms products originating from cultivation, forestry and fisheries (FAO 1997). It is a component of manufacturing sector where value is added to agricultural raw materials through processing and handling. Agro industries carry high multiplier effects in an economy in terms of job creation and value addition through its forward and backward linkages (Silva and Baker 2009). Agro industry is a part of the broad concept of agribusiness that consists of suppliers of inputs to the agricultural, fisheries, and forestry and distributors of food and non food outputs from agro industry (Henson and Cranfield 2009). Agro industry broadly covers the post harvest activities involved in the transformation, preservation and preparation of agricultural products either for intermediary or final consumption (Wilkinson and Rocha 2009).

Agri-business includes farming (crop production), agro input supply, packaging, distribution, processing industries, and marketing (retail and wholesale). Agro processing industries are classified as upstream and downstream industries. Rice and flour milling, leather tanning, cotton ginning, oil pressing, saw milling and fish canning are brought under upstream while bread, biscuit and noodle making, textile spinning and weaving, paper production, clothing and footwear manufacturing come under downstream industries. Intermediate products made in the initial processing of

agricultural materials are further manufactured by downstream industries (FAO 1997). The production process may range from craft through intermediate and highly sophisticated method depending on the level of technology and organizational structure.

Agro industries are useful in enhancing economic benefits of a country. The development of competitive agro-industries is vital for creating employment and generating income opportunities, as well as enhancing the quality of and demand for farm products (UNIDO 2009).

Agro-industries have the capacity to create employment opportunities not only in farming but also in off-farm activities such as handling, packaging, processing, transporting and marketing of food and agricultural products. In addition to that agro-industries carry a significant global impact on economic development and poverty reduction, in both urban and rural communities. However, the full potential of agro-industries as an engine for economic development has not yet been realized in many developing countries (FAO 2008).

C Prospects and Challenges of Agriculture and Agro industries

The UN member states agreed to launch a process to develop a set of sustainable development goals (SDGs) at the United Nations Conference on sustainable development (Rio+20) held in Rio de Janeiro in 2012. Accordingly, a comprehensive path toward sustainable development consists of three interrelated dimension as environmental, economic and social. In promoting sustainability of agricultural production and food security, the production systems operate and constraints they face have to be taken into account in a prudent manner. In particular, land degradation, competition for land, loss of biodiversity, natural resource management, and climate change and the role and needs of small-scale farmers, including rural women are important factors in this endeavor (UN 2013b).

World's agriculture and related economic activities are engulfed with multitudes of issues. It is maintained that nearly 870 million people of the 7.1 billion people in the world, were suffering from chronic undernourishment in 2010-2012 time period. Almost all the hungry people numbering 852 million live in developing countries. It is equivalent to 15 percent of the population of developing counties. In addition to that, there are 16 million people undernourished in developed countries as well (FAO 2012).

The consumption of major agricultural products will go up in the future due to growing population, higher incomes, and urbanization and changing diets, especially in developing countries. The demand for agricultural products in emerging economies with a huge population such as China and India would exacerbate the situation further even though agricultural products in those countries growing to cushion the impact to some extent (OECD-FAO 2013).

It is estimated that there are 5 billions hectares available for food supply worldwide, 1.5 billion of them are used for crops and 3.5 billion as grassland, grazing land and highly utilized steppe. Nearly 2 billion hectares are degraded due to intensive and improper use, with continued degradation amounting to an annual loss of \$400 billion per year. Nearly 80 to 90 per cent of the 868 million food-insecure people in the world reside in regions with strongly degraded or severely depleted soil (UN 2013b).

Agro processing is an important component of the agriculture sector in any country. Even though it contributes to overall agricultural development, agro processing can also give rise to undesirable environmental side-effects. It can create environmental pollution or hazards in various ways: the discharge of organic or hazardous wastes into water supplies; the emission of dust or gases that affect air quality and produce toxic substances; and the use of dangerous machinery that can put the safety and health of workers at risk (FAO 1997). Agro industries grow over time along with the rising production, changing requirements and technological advancement. The rapid growth of agro industries in developing countries poses risks in terms of equity, sustainability and inclusiveness. Agro industries would be sustainable only if they are competitive in terms of costs, prices, operational efficiencies, product offers and other associated parameters and only if the prices they are able to pay farmers are remunerative for those farmers (Silva and Baker 2009).

New agricultural technology should be appropriate to environmental, economic, social and cultural setup of resource poor small scale farmers, while ensuring that farm products are fairly and reasonably priced for supporting small holders for sustainable farming. Vulnerability and marginalization of small scale farmers are high, if there is no sufficient diversification at the farm level. It is essential to develop scale-neutral technologies grounded in the realities of marginalized farmers. Even though women make up high per cent of the agricultural labor force in sub Saharan Africa, East Asia and many developing countries, they do not have equal access to productive inputs and services, such as land, livestock, education, labor, financial services and technology (UN 2013b). The adoption of new capital intensive technologies leads to reduce employment and create negative impact on income distribution (Henson and Cranfield 2009).

Ongoing trend of climatic change pose an increased pressure on soil, water cycles, crop and livestock products. More frequent extreme weather conditions accelerate soil erosion and run-off. Similarly, growing temperature level increase the turnover rates of organic matters affecting negatively for soil composition and water holding capacity while affecting the health of plants, animals, and farmers, increasing pests and reducing water supply pose a great threat to increase desertification and land degradation. In addition to that, increased ozone levels would harm key crops and cause negative impacts on the nutritional quality of various foods. Massive investments are essential in roads, irrigation efficiency and expansion and agricultural research to cushion the impacts of changing climatic change (UN 2013b).

Increases and transformation of agricultural production and agro industrialization have profound implications on land usage bringing even more marginal lands, potentially sensitive lands into cultivation possibly creating environment to deforestation, desertification and loss of biodiversity; similarly, the environment impact of agro industrialization can induce changes in type and level of agro chemical usage. The agro industrialization can have critical impact on availability and quality of water, especially in developing countries. Agro industrialization carries a profound impact on the level of energy uses and potentially detrimental environmental effects associated with waste from the agro processing sector (Henson and Cranfield 2009).

Agro industries would complicate the situation further, if prudent initiatives are not taken timely. In order to minimize the impact of agro-industrial residues on the

environment, administrative tools to limit such releases must be introduced and amended to meet the need of new challenges. The legislation prohibiting the discharge of residues into the environment is a direct intuitive in this endeavor. Such incentives as soft loans to invest in control measures can be coupled with legal provisions. Similarly, economic disincentives as penalizing of polluting industries could also be introduced. Further more pollution entitlement shares and permissible limits (including trade permits); taxes on inputs or resource use rather than on the level of pollutants; subsidies to invest in environmentally friendly technologies; fees to cover the costs of removing pollutants, etc can be introduced as complementary initiatives (FAO 1997).

The world agricultural production is expected to grow 1.5% annually over the coming decade, compared with annual growth of 2.1% between 2003 and 2012. The growing resource constraints including limited expansion of agricultural lands, rising production costs and the increasing environmental pressures are the main factors behind this trend. Prices of crop and livestock products will remain above the historical averages over the medium term due to slower production growth and strong demand, including for bio fuels (OECD-FAO 2013).

The scope of sustainable development encompasses the economically, socially and environmentally sustainable future for the planet and for present and future generations while freeing humanity from poverty and hunger. In promoting agriculture, a resilient food system must be supported by actors along the entire value chain, including farmers, the input and processing industries, retailers and consumers (UN 2013b).

CONCLUSION

It is widely discussed that production shortfalls, low stock files in major food producing and consuming countries, price volatility, climatic vagaries and trade disruption would check the stability and sustainability of the agricultural sector including agro industries. The food crisis in 2008 created a number of socioeconomic and political confusions in many parts of the world, especially in developing countries. Agro industry would prosper, if the entire agricultural sector performs well. As opposed to policy-driven as it was in the past, agricultural sector virtually anywhere in the world is turning into market-driven sector, so that the sector is susceptible for regular fluctuations in production, distribution, consumption among different geopolitical areas in the world.

Agriculture has been the oldest vocation in all societies since time immemorial; it is still the centre of gravity of livelihoods, culture, social values, and politics in many countries. Allocation of resources for agriculture (cultivation, harvesting, packaging, transporting, storage, marketing and agro industry), policy designing and policy implementation have been engulfed with chronic and complicated problems at regional, national and global level. A sustainable agricultural setup is essential to maintain the medium and long-term delicate socioeconomic equilibrium the world.

REFERENCES

Apostolides, Alexander, Stephen Broadberry, Bruce Campbell, Mark Overton, Bas van Leeuwen (2008), *English Agricultural Output and Labor Productivity, 1250-1850*, <http://www.basvanleeuwen.net/bestanden/agriclongrun1250to1850.pdf>,

- Committee on Agriculture 2011-2012 (2012), *Cultivation of Genetically Modified Food Crops: Prospects and Effects*, Report No. 37, Lok Sabha Secretariats, New Delhi.
- FAO (2012), *The State of Food Insecurity in the World 2012*
<http://www.fao.org/docrep/016/i3027e/i3027e00.htm>
- FAO (1997), *The State of Food and Agriculture*,
<http://www.fao.org/docrep/w5800e/w5800e12.htm>
- Gaud, William S. (1968), *The Green Revolution: Accomplishments and Apprehensions*, The Society for International Development, Washington, DC.
<http://www.agbioworld.org/biotech-info/topics/borlaug/borlaug-green.html>
- Henson, Spencer and John Cranfield (2009) 'Building the Political Case for Agro Industries and Agribusiness in Developing Countries', in Silva, Carlos A. da, Doyle Baker, Andrew W. Shepherd, Chakib Jenane and Sergio Miranda-da-Cruz (Eds.), *Agro Industries for Development*, CAB International and FAO.
- Hunger Notes (2013), *2013 World Hunger and Poverty Facts and Statistics*,
<http://www.worldhunger.org/articles/Learn/world%20hunger%20facts%202002.htm>
- Idrisi, Zohor (2005), *The Muslim Agricultural Revolution and its Influence on Europe*, Foundation for Science, Technology and Civilization, Manchester, UK.
- OECD-FAO (2013), *Agriculture Outlook 2013-2022*,
<http://www.oecd.org/site/oecd-faoagriculturaloutlook/oecd-fao-expect-slower-global-agricultural-production-growth.htm>
- Silva Carlos A. da and Doyle Baker (2009) 'Introduction' in Silva, Carlos A. da, Doyle Baker, Andrew W. Shepherd, Chakib Jenane and Sergio Miranda-da-Cruz (Eds.), *Agro Industries for Development*, CAB International and FAO.
- Weisdorf, Jacob L (2005), 'From Foraging to Farming: Explaining the Neolithic Revolution', *Journal of Economic Surveys*, Vol.19, No.4, Blackwell Publishing Ltd, Oxford.
- Wilkinson, John and Rudi Rocha (2009), 'Agro Industry Trends, Patterns and Development Impacts', in Silva, Carlos A. da, Doyle Baker, Andrew W. Shepherd, Chakib Jenane and Sergio Miranda-da-Cruz (Eds.), *Agro Industries for Development*, CAB International and FAO.
- Wimalaratana, W (2011) *Agriculture and Rural Development in Sri Lanka: S.M.P. Senanayake Felicitation volume* (Ed.), Department of Economics, University of Colombo.
- UN (2013a), *Summary of the Expert Group Meeting on Science and Sustainable Development Goals*, UN Headquarters 20-21 March, 2013.
- UN (2013b), *Sustainable Development-Agricultural Technology for Development*, General Assembly, 19 August 2013.
- UNIDO, *Industrial Development Report*, 2009.

IMPLEMENTATION OF PRECISION FARMING IN GREEN AGRO-INDUSTRY CONCEPT

Sakae Shibusawa

Department of Environmental and Agricultural Engineering, Tokyo University of Agriculture and Technology, Fuchu, Japan

Tel: +81-42-367-5762, Email: sshibu@cc.tuat.ac.jp

ABSTRACT

My interest has been focusing on trends and prospects on precision agriculture (PA) in a point of view of Asian countries during the years. This time focuses on a risk management approach of GAP, that is, good agricultural practices which are well organized into the GLOBAL G.A.P. structure. A key issue is the one-step-up and one-step-down strategy which offers the traceable farm management with recording. Practice of precision agriculture implies evidence-based farm management using spatio-temporal variability records in cultivation, resulted in information-oriented fields and information-added produce. Both strategies of precision agriculture and GLOBAL G.A.P. can be embedded in a single action of farm management. This paper was presented at the 5th ACPA, Korea.

Keywords: traceability, evidence-based, management, technology package

INTRODUCTION

A short review found phrases on community-based and small farms at the executive meeting in Suwon 2003, on-going practices by learning groups at the 1st ACPA in Toyohashi 2005, branded-produce strategy at the 2nd ACPA in Pyeongtaek 2007, thinking process in decision at the 3rd ACPA in Beijing 2009, and at the 4th ACPA in Obihiro 2011 an agro-wisdom robotics strategy (Shibusawa 2004, 2011). The issues above have been partly implemented in public-funded projects for research or business purposes.

On the other hand dangerous works have been existed in agriculture with 400 victims by farm work accidents every year, followed by food safety issues and environment issues, in addition to restoring projects from the East-Japan catastrophe (Shibusawa 2012a). This has led us to concentrate into a strategy of agro-architecture which is implying the re-construction of all of the agriculture. One of the keen issues is a risk management approach of GAP good agricultural practice. The GLOBAL G. A. P. statement is a worldwide farm management strategy of integrated farm assurance, food safety practice HACCP-based, cost of compliance, and integrity of farm assurance. The one-step-up and -down strategy offers a key protocol of traceable farm management (Baerdemaeker 2012). The GLOBAL G. A. P. rules should be implemented while taking account local legislation into. The G. A. P. growers have to find best collaborators from a pool of suppliers, wholesalers and retailers to create best food chains.

In 2010 Japan had a package of domestic regulations as a guideline for G. A. P. promotion, which was a table of control points and critical compliance on food safety, environmental conservation and workers protection, administrated by Agricultural Production Bureau, Ministry of Agriculture, Fishery and Forestry. The guideline covers all crops of fresh vegetables, rice edible, wheat edible, fruits edible, tea, forage crops, other edible crops, other non-edible crops, and mushrooms, except for livestock farming and aquaculture(Shibusawa 2012b).

Recording is the fundamental action of the G. A. P. Everybody knows that precision agriculture involves evidence-based farm management accompanied with records on cultivation, resulted in information-oriented fields and information-added produce. This is why this article will discuss on matching between the G. A. P. and PA.

A.Two Faces Of Good Agricultural Practice

The FAO COAG 2003 GAP paper stated that Good Agricultural Practices (G.A.P.) are practices that address environmental, economic and social sustainability for on-farm processes, and result in safe and quality food and non-food agricultural products. On the other hand precision agriculture (PA) provides a thinking process such as (1) describing the facts and evidence with spatio-temporal coordinates to understand the variability of the field, (2) making decision and action in correct time and location, (3) recording the results of actions, and (4) reviewing the approaches, followed by field-base GIS. It is easy to combine the G.A.P. strategy and precision agriculture approach, as shown in Fig. 1. The PA approach provides the information on profit and risks to farmers and the GAP strategy provides compliance to retailers from the single action of evidence-based farm management.

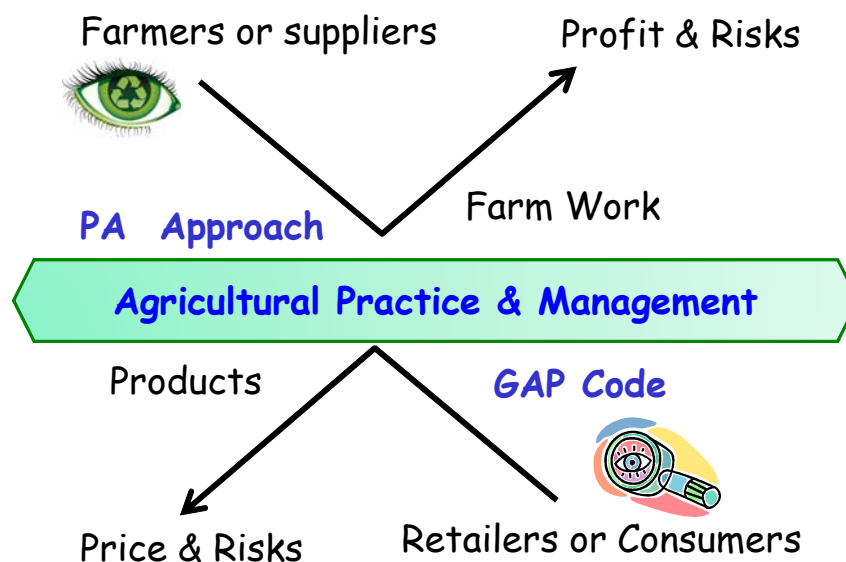

Figure 1. Two faces of farm practices

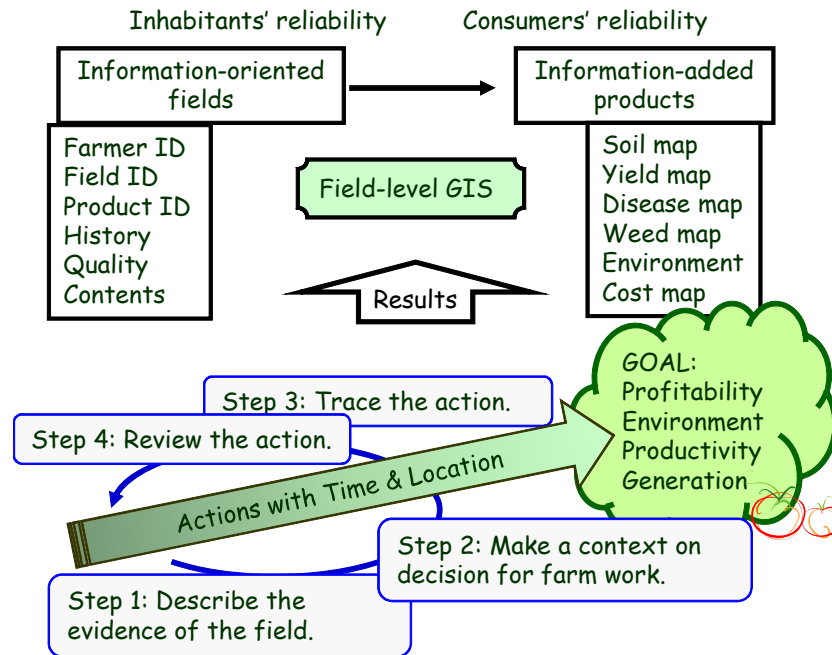

Figure 2. Traceable Farm Management of Precision Agriculture.

B. Actions In Precision Agriculture

1. Recording

What is a merit when precision agriculture is introduced? Depending on country or cultivating crops, though one reply is what the actions create information-oriented fields and information-added products by logical process of traceability (Fig. 2).

The recording creates a field-level GIS of big size data which is applicable to decision support of farmers. McCown (2005) reported that a number of decision support systems developed were not used in farmer's practice but used as a learning tool. He also emphasized the differences between objective knowledge embedded in a decision support system and the subjective knowledge which normally guides the actions of farmers in familiar situations, local, personal, and social environment. Consequently who makes decision is an important factor for the GIS application.

2. Community-Based

Managing the hierarchical variability: within- and between-field, and among-farmers variability leads us to organize a learning group of wisdom farmers and a technology platform of companies under rural constraints (Shibusawa 2004). An agricultural corporation, Aguri Co., Ltd., has experienced a new scheme of precision paddy management. With the data collected from the fields with more than 5-year organic management using the real-time soil sensor, they have kept quality and yields of production, in addition to increases in total carbon and total nitrogen of soil. The produce is all sold by direct contract to customers and the fertilizer was made from organic city garbage. A lot of paddy fields have been rented from neighboring aged

formers. With this context AGURI is conducting Carbon-farming (Shibusawa et al. 2012).

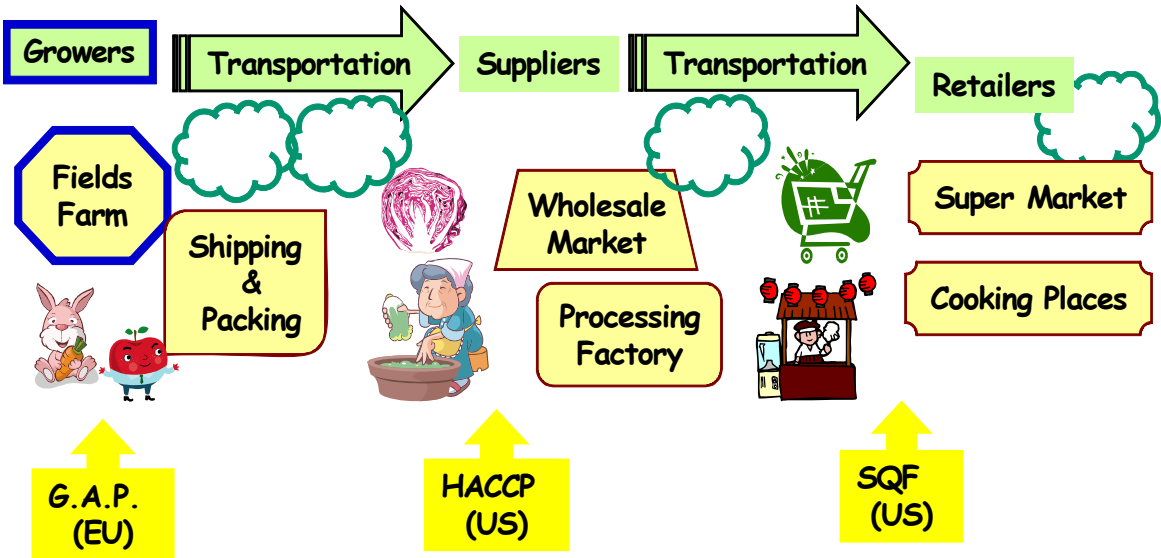

Figure 4. History-Losing Points in Food Chain.

3. Responsibility Of Food Chain

When precision agriculture and G.A.P. strategy is introduced, the traceability is performed on the farm. If consumers request the traceable produce to the PA growers, they have to also ask all stakeholders of the food chain for keeping risk management on every step, since there are many control points of food chain as shown in Fig. 4.

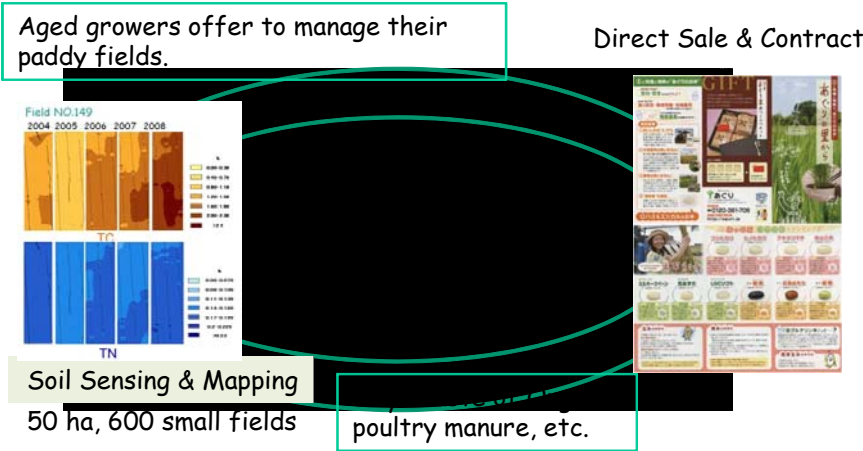

Figure 3. Sustainable Paddy Management towards Carbon Farming by AGURI co

C. Structure Of Global G.A.P.

1. Good Practices

Three terms are introduced here: GLOBAL G.A.P., HACCP and SQF.

a. GLOBAL.G.A.P.

The introductory statement of GLOBAL G.A.P. says as follow:

- (1) GLOBALG.A.P. is a private sector body to set out voluntary standards for the certificate of agricultural (including Aquaculture) products around the globe.
- (2) GLOBALGAP is a global scheme and a reference for Good Agricultural Practice (G. A. P.), which is managed by the GLOBALGAP Secretariat.
- (3) FoodPLUS GmbH a non-profit industry owned and governed organization, legally represents the GLOBALGAP Secretariat.
- (4) GLOBALGAP is an equal partnership of agricultural producers and retailers that want to establish certification standards and procedures for the Good Agricultural Practices.
- (5) GLOBALGAP provides the standards and framework for independent, recognized third party certification on farm production processes based on EN45011 or ISO/IEC Guide 65.
- (6) GLOBALGAP Integrated Farm Assurance standards is a pre-farm gate standard that covers the whole agricultural production process of the certified product from before the plant in the ground (origin and production material control points) or from when the animal enters the production process to non-processed and product (no processing, manufacturing or slaughtering is covered). The objective of GLOBALGAP certification is to form part of the verification of Good Practices along the whole production chain.
- (7) GLOBALGAP is a business-to-business tool and is therefore not directly visible to the final consumers.
- (8) The GLOBALGAP logo and Trademark have restricted use.

b. HACCP

HACCP stands for Hazard Analysis and Critical Control Point required for implementing ISO 22000 or SQF Food Safety Management System. HACCP is based on seven principles: (1) Conduct a Hazard Analysis, (2) Identify the Critical Control Points, (3) Establish Critical Limits, (4) Establish Monitoring Procedures, (5) Establish Corrective Actions, (6) Establish Record Keeping Procedures, (7) Establish Verification Procedures.

c. SQF

SQF is recognized by retailers and foodservice providers worldwide who require a rigorous, credible food safety management system. Using the SQF certification program

will help reduce assessment inconsistencies and costs of multiple assessment standards. The SQF Program is recognized by the Global Food Safety Initiative (GFSI).

The SQF institute has also given a definition of G.A.P. as Good Agricultural Practices means practices on farms which define the essential elements for the development of the best practice for production, incorporating integrated crop management, integrated pest management, and the integrated agricultural hygiene.

D. Structure Of Global G.A.P.

The mission and the decision making system of the GLOBAL G.A.P. was illustrated in Fig. 5. GLOBALGAP must always be implemented while taking local legislation into account. It is stated in the normative documents that relevant local legislation takes precedence over GLOBALGAP. There are also specific reference to local legislation in several Control Points and Compliance Criteria. National Technical Working Group has responsibility for the issues. The control points and the GLOBAL G.A.P. system are also illustrated in Fig. 6.

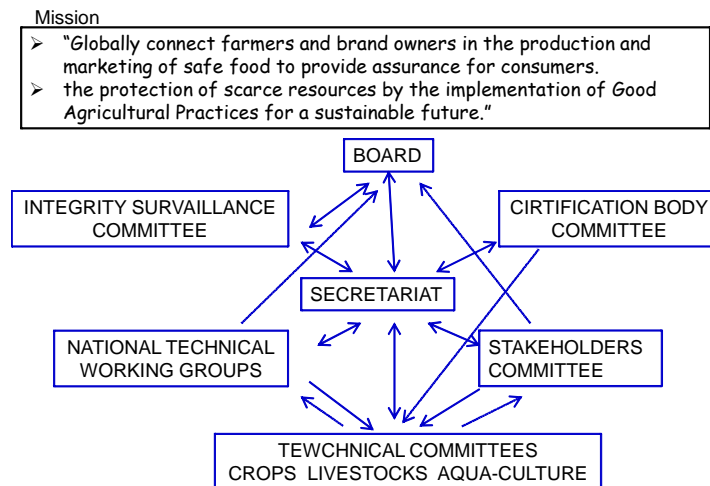

Figure 5. Mission and Decision Making System of GLOBALG.A.P

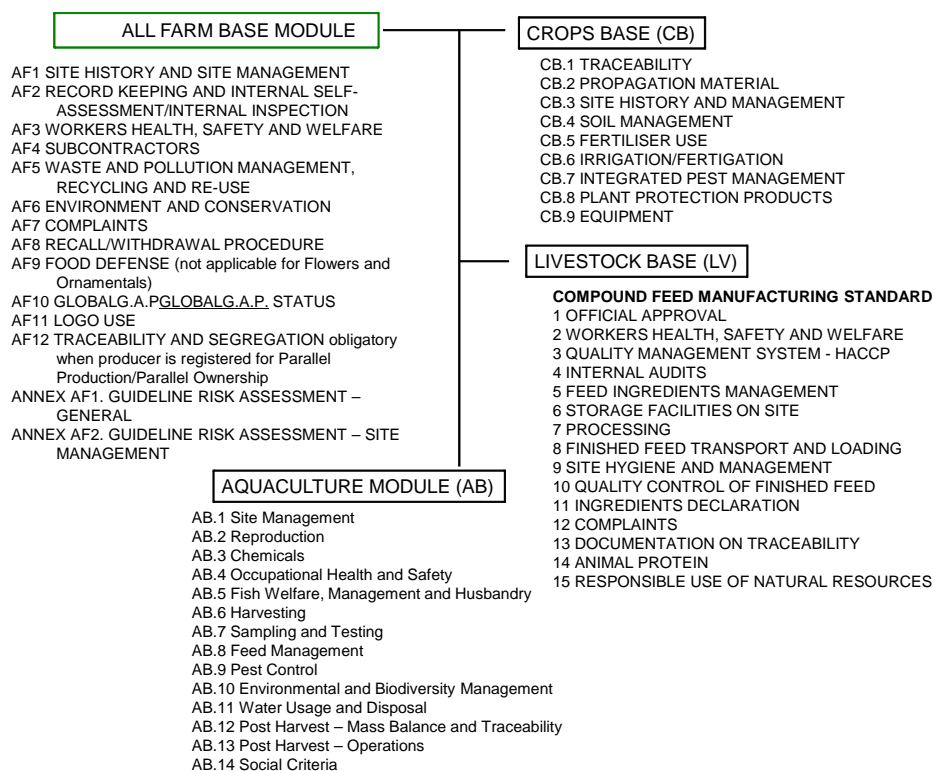

Figure 6. Control Points and Structure of the GLOBALG.A.P. system

CONCLUSIONS

Good Agricultural Practices are implemented by practices in precision agriculture. Technology development should meet the need of strategies of both G.A.P. and PA.

REFERENCES

- Baerdemaeker J. D. 2012. Precision agriculture technology and robotics for good agricultural practices. Presented at *International Symposium on GAP oriented Farm and Food Management*, ChonAn city, Korea. KSAM.
- Shibusawa, S. 2004. Paradigm of value-driven and community-based precision farming. *Int. J. Agricultural Resources, Governance and Ecology*, 3 (3/4) 299-309
- Shibusawa, S. 2011. An Idea of Agro-wisdom Robotics for Precision Agriculture. In (on CD-ROM) *Proc. 4th ACPA*, Obihiro, Japan.
- Shibusawa, S. 2012a. Precision restoring approach to the east Japan catastrophe - Actions of JSAM -. In (on CD-ROM) *Proc. 6th ISMAB*, Jeonju, Korea. CIAM/KSAM/JSAM.
- Shibusawa, S. 2012b. Good agricultural practice (GAP) requires precision farm management. Presented at *International Symposium on GAP oriented Farm and Food Management*, ChonAn city, Korea. KSAM.

Shibusawa, S., Kodaira, M, Li, Y., Oomori, T., Siti Noor Aliah, B. 2012. A scheme of precision carbon farming for paddy. In (on CD-ROM) *Proc. 11th ICPA*, Indianapolis, USA.

McCown R. L. 2005. New thinking about farmer decision makers. In *The Farmer's Decision*, 11-44, Ed. J. L. Hatfield, Soil and Water Conservation Society.

NEW APPROACHES IN MANAGEMENT AND UTILIZATION OF AGRICULTURE WASTES IN THE WANA REGION

Hassan M. El Shaer
Desert Research Center,
1 Matahaf El Martaria Str. P.O. Box 11753, Mataria , Cairo, Egypt
Email: hshaer49@hotmail.com

ABSTRACT

West Asia and North Africa (WANA) Region is characterized by high population growth, degraded and fragile natural ecosystems as consequences of climate change. Exploitation of non- conventional resources such as agriculture wastes or residues (all field crops and agro- industrial by-products) for economic agricultural and industrial products is increasingly needed. Many countries have realized, in the last decade, the advantages of agricultural residues (AGR) on the economy, industry and environment. This article aims at casting lights on potential management and usages of common agriculture residues (wastes) in WANA region. It focuses on identification of potential AR and common utilization technologies. Constraints and strategies for management and utilization are also discussed. More than 440 million tons of AGR (on dry weight basis) are produced in the region. Its quantities, types and technologies varied among the WANA countries. Most of AGR are either burned or utilized in an inefficient way , mainly as animal feeds and composting. Scientists and decision makers have expressed their interest in using such materials to produce industrial and agricultural products. At least ten main technologies for AGR utilization were identified. Fully exploitation of AGR would be expected to foster the development of small scale agro-industries, create new job opportunities, and provide new arable lands in addition keeping the environment clean and unpolluted. In conclusion, agriculture residues have to be considered as valuable renewable materials since many privileges could be achieved through proper management and utilization technologies.

Keywords: *agriculture residues, feeds, food, compost, renewable energy*

INTRODUCTION

West Asia and North Africa (WANA) Region is characterized by high population growth and erratic weather conditions, limited area of arable lands, with fragile natural resources base for agriculture and acute water shortage at present. Agriculture plays an important role in the economies of most of the countries. Despite the fact that WANA region is the most water-scarce and dry region worldwide, many countries across the region are highly dependent on agriculture. Large quantities of agriculture residues(AGR) such as field crop residues and agro- industrial by- products are produced annually and are vastly underutilized. The need for food to cope with the increased population, the limited and exhausted available lands and climate change impact necessitate a rational utilization of such AGR. On the other hands, many countries in the

region are suffering from shortage of raw materials which are very necessary for agriculture and industrial purposes. Such renewable materials could be generated from recycling of AGR. For instances, utilization of AGR as compost may contribute to expansion of arable lands through its use for reclamation of soil, and reduce irrigation requirements (El-Shimi *et al* 1992 & Sadik *et al* 2010). Moreover, when AGR are used as animal feeds, it will improve animal production and decrease the cost of animal products (El Shaer 2004 and Al Tonobey & El Shaer 2010). A recent study conducted by FAO/RNE (2007) on agricultural residues in the region revealed that there is more than 440 million ton of AGR on dry matter weight basis. Pakistan, Turkey, Iran and Egypt have the highest AGR available in the Region. The same study reported that the total amount of AGR available in the whole Arab world amounts to 155 million tons representing 35% of the total AGR in the Region. Egypt produces the highest AGR in the Arab world. However, most of these residues are not fully explored ; AGR is either burned in the field or utilized humbly for animal feeds, charcoal and composting production (Abdel-Maksoud 1999 & El Shaer 2004). AGR could have an important role in bridging the food gap in many WANA countries when is fully exploited. AGR potentially could be utilized for several agriculture and industrial materials production in rural and peri-urban areas (Wadhwa et al 2013). The paper focuses on classification, advantages, general constraints of AGR utilization and common technologies for utilization. The proposed strategies for utilization of AGR are, also, briefed.

AGRICULTURAL RESIDUES DEFINITION AND CLASSIFICATION

Agricultural residues are the secondary product of most of agricultural activities such as vegetative parts left after harvesting vegetables, fruit tree pruning and wastes from food processing and agro-industries plants which include; stalks, stovers, straws, bagasse, or beet molasses, hulls, oil filtered cakes, fruit and vegetable residues, and fruit trees pruning, date palm and date residues, in addition to agro-industries wastes such as tomato and potato wastes, rice bran, hulls, husks, and cotton seeds.

AGR may be classified differently according to the source of their extraction as follows:

1. Fields and gardens (e.g. residues of field crops and products of pruning of fruit trees)
2. Food and agro-industrial wastes (including agricultural fiber processing plants; bagasse in sugar mills, tomato and potato wastes, rice hulls and husks and cotton seeds extraction and other oil processing plants, etc).
3. Fruit and vegetable markets (refused low quality of fruits and vegetables).
4. Municipal wastes; house hold, restaurants and hotel organic residues.

The concerned AGR in this article include: field crops, fruit residues (pruning, harvesting, processing, packing, etc), landscaping residues and agro-industrial wastes.

A. Advantages and Significance of The Utilization of Agricultural Residues:

It is worth mentioning that recent concerns about increased cost and reduced availability of fossil fuels, feed, food and other raw materials, improved human nutrition, and environmental degradation have prompted scientists to re-evaluate the current agricultural by products management and utilization. The awareness of the economic value of AGR is increasing nowadays all over the world.

The benefits that can be derived from the utilization of agricultural residues would be:

1. Provide opportunity for new clean environment friendly source of energy
2. Fostering organic agriculture thus promote agriculture products exportation.
3. Reduce lands used for fodder production, thus provide more land for food production.
4. Creation of new small agro-industries in the rural and peri-urban areas.
5. Utilization of the available AGR for fiber board woods production instead of importing wood from abroad.
6. Creation of new job opportunities particularly for women in the rural areas.
7. Reducing the costs of animal and poultry feedstuffs thus increasing animal and poultry products at reasonable prices.
8. Manufacture of bio-fertilizers at economic costs.

The significances of agricultural residues could be briefed in the following points:

1. They are available in most rural areas which means that all local communities have their own share in these residues and future activities.
2. AGR are annually renewable material resources and are reasonably cheap.
3. AGR are easily accessible; don't need sophisticated equipments for their extraction.
4. There is a base for innovative technologies for AGR utilization stemmed from the familiarity with accumulated knowledge and technical heritage on available AGR.
5. The economic use of AGR preserves the environment by eliminating the use of pesticides to combat against rodents, and pests (e.g., cotton pink worm).
6. Attention of public, private sectors and research institutions to AGR could inspire the innovation and development of endogenous knowledge of local communities.

B. Economic Return Of Investment In AGR Utilization

Burning waste field crops is one of the main causes of environmental pollution. Such problems should be alleviated by raising economic interest in the recycling of these "waste" materials to generate extra income for the farmers. By demonstrating the added economic benefits of utilizing agriculture waste materials, economic modernization and diversification could be promoted to reduce poverty by offering an added income-earning opportunity to local farmers. However, utilization of such AGR materials should reduce the need to import more expensive food, feed, bio-fuel and building materials (Abo-Hegazi, 2004). The economic and environmental benefits derived from recycling and utilization of AGR can help to offset high costs of fuel, fertilizers, animal feeds, etc, in addition to alleviating the pollution problems. These economic benefits could show a promising approach for recycling AGR. However, as mentioned previously, several commodities or products would be generated from different models of AGR utilization such as: compost, clean energy animal and poultry feed, food (mushroom), wood, charcoal, active carbon, ethanol, bakers and fodder yeasts and CO₂ and other chemicals, bales of straw for building, paper pulp, substitute for cement in building operations (Abdel-Maksoud 1999 & El Shaer 2004 & Hamdi 2004 & Wadhwa et al 2013). The economic return of investments in AGR utilization is varied and depending on the type of AGR conversion and its products. Results showed that for every one Egyptian Pound (LE) invested in compost, 2.8 LE are gained. In case of biogas, every one pound invested gained 3.15 LE. For silage, every pound invested gained 20 – 28 LE (Abdel-Maksoud 1999).

C. Technologies & Utilization Of Agricultural Residues:

At Least ten main technologies for utilization of agricultural residues have been identified in WANA region. They are used at different stages of development, i.e. some technologies are developed and applied, others are at a pilot stage and some are still under R&D (Hamdi 2004). The most important and common ones are:

1. Fodder usage; feed blocks, silage, biological treated feed materials.
2. Composting with conventional and organic products.
3. Mushroom production
4. Fuel and energy (charcoal, electricity, biogas).
5. Structural use (roofing, walls, building material, gypsum- fiber- boards)
6. Industrial materials: used in construction and wood working industries.
7. Chemical industrial producing products substituting wood and/or plastics (fiber board, pulp, wood plastic composites, fiber –reinforced plastics, bioplastics).
8. Furniture items, interior fittings and parquet.
9. Light goods and utensils (stationary items, packing material and packages)
10. Fermentation products (yeast, ethanol, vinegar ...etc)

The most beneficial technologies for AGR utilization could be summarized as follows:

1. Utilizing Rice Straw Or Rice Husks For Manufacturing Bricks

Various percentages of mixture of either loam and sand or cement and sand were utilized for producing bricks after the addition of variable amounts of 1-2 mm in length of rice straw or rice husks then dried. Some of resulted bricks of loam (Tafla) were burned to produce burned (or red) bricks while bricks of the cement were kept without burning (Gomaa et al 1998 & Abo-Hegazi 2004). The bricks included rice waste were in good quality; seemed to be more lighter weight than that of non waste addition.

2. Production of Silica Gel

Production of silica gel silicates from the rice hulls and straws are very promising. El Mahdy et al (2004) reported that silica gel has been widely used in edible oil refining and frying oil treatment as an alternative to caustic soda addition, as pharmaceutical products, detergents, adhesives, chromatographic techniques and ceramics. The produced silica gel not only alleviates the problem's associated with rice hull or straw disposal but also generates a high profit margin, value added product and creating a profitable new industry in rural localities in Egypt .

3. Wood Production

Utilization of AGR for the production of woods, as substitutes for the imported wood would save millions of Dollars, in addition provides new avenues of the investments. Wood has some accordance in chemical analysis with some AGR. For instances, Abo-Hegazi (2004) reported that that rice straw contain from 46-59% cellulose, 11-15% lignin, 21-25% pentosan but that of wheat contain 48%-57% cellulose, 16-17% lignin,

28% pentosan' and barley straw contains 44-49% cellulose, 16-19% lignin, 23%-32% pentosan. Bagasse content of the same materials are: 46%, 20% and 25%, respectively. Corn stalks contains 38%, 34% and 20% from the same materials respectively. Wood, in general, contains approximately 58-67% cellulose, 20-34% lignin and 11-27% pentosan. Panel board, MDF and HDF woods can be produced by getting rid of some substances (such as leaves which have a very low content of cell fibers and a high content of silicates), then appropriate binders and small amounts of additives such as paraffin wax combined with pressure under heating followed by trimming of the resulted boards (Abo-Hegazi 2004). Properties of MDF and HDF were almost similar to that originated from wood-wastes or bagasse.

4. Organic Growing Media Production

The use of compacted rice straw bales as an organic growing media in green houses and open field production is a new approach in the region. It has been developed to control soil born pests and diseases as well as weeds instead of methyl bromide. Green house trials were successfully carried out using this technique to produce better fruit quality and higher yields of cucumber, pepper cantaloupe and strawberries. The application of these methods in open field provides the opportunity in particular for the utilization in the new agriculture desert areas to produce high quality crops and to promote organic cultivation. The organic recycled materials could be used as a cultivation media or an alternative to peat moss that has to be imported (El- Shimi et al 1992).

5. Compost Production

Composting is a method of converting AGR into dried, non-odoriferous, through aerobic bacterial activities, fertilizer. AGR can be composted and used to replace a significant part of the mineral nitrogen fertilization with nitrogen recovery of 6–22 percent (El- Shimi et al 1992& Sadik et al 2010). Compost provides the plant with required nutrients and provides the soil with nitrogen, phosphorus and potassium, trace elements and humus. Compost improves the soil physical and chemical and properties of the soil. It increases its water holding capacity and the cation exchange capacity as well (Sadik et al 2010). The long-term compost applications improved the nitrogen status of the soil over the years (Tits et al 2012).

6. Bio-Ethanol

Recently bio-ethanol is a world demand to overcome the depletion of fossil fuels and their ever increasing prices. In addition, it minimizes the global warming, creates job and increases welfare for the rural community through a better life style. Ethanol is an oxygenated fuel that contains 35% oxygen, which reduces NO_x emissions from combustion (Hamdi & Wafaa M. Amer, 2007). They also pointed out that some of AGR resources can either be used directly as an untreated material for microbial growth or be used by appropriate treatment with enzymes for bioenergy production. The products generated from perishable wastes can be in liquid or gaseous forms of biofuels. Amongst various wastes used for ethanol production, potato peels, apple pomace, waste

apples (Tahir and Sarwar, 2012), banana peel, banana waste, beet waste, beet pomace and peach wastes have shown encouraging results (Dhabekar and Chandak 2010).

7. Bio-Gas

Bio-gas is the result of microbial degradation of lignocelluloses materials (i.e., agriculture residues, animal excreta, mushroom spent, etc.) under anaerobic conditions in a liquid medium. Many systems have been developed to produce bio-gas such as the Chinese and Indian models. Small and large scale digesters made of polyethylene have been developed. The main product is bio-gas which is used for heat, cooking, light and/or electricity generation in rural areas. Another product is the slurry which contains sludge that could be dried and pulverized and used as a soil fertilizer (El-Shimi et al 1992) or could be used as a part of feed ingredients at a ratio of 30% for small ruminants (El Shaer 1994). Bio-gas manure is free from the offensive odour normally associated with manure pits/heaps. Bio-gas can be used to power internal combustion engines and to substitute for diesel oil in small electric generators.

8. Charcoal production

Charcoal is a carbonaceous solid with a fixed carbon content of 70% or more. It is usually manufactured from hardwoods or other dense biomass by pyrolysis. Charcoal is used as a fuel for heating and barbecue. It is also employed as a reductant for metal ores and other industrial purposes. In the developed countries efficient processes are employed for charcoal production in big industrial kilns, retorts and portable steel kilns. Meanwhile in the developing world inefficient processes are widely used for charcoal production (Gomaa et al 1998). Because of pollution associated with the inefficient conversion of biomass to charcoal, this charcoal fuel cycle is among the most greenhouse-gas intensive energy source employed by mankind. Traditionally, in Egypt such inefficient process is widely spread in the rural areas. A new efficient and developed process is highly recommended for solving such problems (Gomaa 2004).

9. Mushroom Production

Straws, wood and animal manure have been used for mushroom production. Mushroom has is very nutritious food ingredient which high protein content on a dry weight basis as compared with other food (El-Shimi 2004). Major mushroom varieties are *Agaricus* (button mushroom), heat-loving mushroom *Volvariella volvacea* (straw mushroom) and *Pleurotus sajor-caju* (oyster mushroom). The two latter mushrooms can grow on AGR and do not require strict controlled growing conditions (El-Nawawy 1998). Hassan (2000) reported that mushrooms (*P. ostreatus* and *A.bisporus*) protein contain all essential amino acids totaling 26- 28 g/ 100g protein. The limiting amino acids in mushrooms are methionine and cystin, while lysine is the dominant amino acids in almost mushroom types, thus mushrooms considered ideal supplement for other lysine-deficit protein such as cereal protein (Hassan 2000). The spent is the major residues of mushroom production; it is the material remaining after harvesting mushroom that can be used for : 1) Upgrading animal feed, 2) A substrate to generate biogas, 3) A substrate

for paper manufacture, 4) A substrate for *Agaricus* mushroom and 5) A substrate to increase soil fertility due to humic and folic acids content.

10. Animal and Poultry Feed Production

Most of AGR are considered good quality feeds since it might be offered to animals directly or after especial processing methods to improve their utilization and economic value. Green AGR can be directly fed to animals. Dried residues, e.g., hulls of rice, faba beans, lentils, soybean, ground nuts, cotton seed, and sunflower seeds can be added at the rate of 5 % of the ration of livestock (El Shaer 2004). Pulverized straws of wheat, sugar cane, maize, all vegetable and fruit residues are also used as feed; wheat bran can be used up to 20 % safely. Some AGR should be treated before feeding. However, approaches for improving AGR feeding value can be summarized as follows:

- a) Physical and mechanical methods such as grinding, crashing and pelleting,
- b) Chemical methods as alkali hydrolysis or ammonia or urea treatments, etc.,
- c) Biological methods (fungi, bacteria) or anaerobic fermentation method (ensiling),
- d) The use of substances which regulate the ruminal digestive processes,
- e) Feed block processing method, and F) Combinations of the above.

However, the treatments used for upgrading the quality of the AGR as feed materials and the research approaches need to consider the potentiality of adoption by the farmers.

The most common processing method in WANA region are :

- a. **Silage:** Silage is an anaerobic fermentation process where fresh AGR would be ensiled with other feed ingredients in a silo. The ensiling process has many advantages, mainly: to improve the nutritive value and consumption of the ensiled materials as well as save this feed for critical time, particularly during the feed shortage (Badurdeen et al 1994 and Ben Salem & Nefzaoui 2003). For instances, ensiling rice straw (whether treated or not) with berseem (*Trifolium alexandrinum*) resulted in a clear improvement in the performance and daily live weight gain of fattening sheep (El Shaer et al 1992 & El Shaer 2004).
- b. **Ammoniation with ammonia or urea :** Ammoniation of AGR with ammonia or urea is an important process to increase the protein contents and to improve the feed consumption and nutritive values of agriculture residues, in particular the crop residues (Sansoucy 1986 and Kakkar & Sukhvir 1993. The reaction must take place in a closed environment, it may take 8 weeks in winter and less in summer (El Shaer 2004).
- c. **Feed blocks :** Feed blocks are a solidified mixture of agro-industrial by-products and other field crops mixed with some other feed ingredients. They are considered as catalyst supplement allowing balanced supply of nutrients, e.g, energy, nitrogen, minerals and vitamins (Sudana & Leng 1986 and Salman 2004). The majority of fruit and vegetable wastes like tomato pomace, bottle gourd pomace, citrus pulp, carrot pulp, baby corn husk and forage, cabbage and pea pods, pineapple waste, olive cake, date seeds and pineapple bran, etc. are highly fermentable and perishable, mainly because of high moisture, total soluble sugars and crude protein contents. There are no standard formulas for blocks, since ingredients choice is related to available substrates and local means of farmers. Nevertheless, some

specific characteristics of ingredients are to be considered in relation to their respective roles. In most cases, blocks include urea, molasses, a binding agent (cement, clay, lime), a fibrous substrate and salt. Minerals, some other by-products, drugs, vitamins are sometimes added (Ben Salem & Nefzaoui 2003 and El Shaer 2004).

- d. Physical and dehydration treatments:** Grinding and/or pelleting and dehydration lead to a reduction in particle size and density. Associated with these changes, an increase in voluntary intake, a reduction in digestibility and increase in the efficiency of the utilization of metabolizable energy are obtained. Grinding led to an increase of 25% in voluntary intake, of 98% in daily live weight gain and of 36% improvement in conversion efficiency (El Shaer et al 1994 & El Shaer 2004). A study was conducted, in KSA, to evaluate the effect of dehydration treatments of five types of AGR, as feeds, on chemical and microbiological analysis and nutritive value (Al Tonobey & El Shaer 2010). These materials were namely: 1- Landscape mowing grasses (LMG), 2- Mixed ornamental plants residues (MOPR), 3- Olive trees pruning (OTP), 4- Citrus tree pruning (CTP), 5- Date trees pruning (DTP), 6- Horse stable grasses residues (HSGR) and 7- Green houses by-products (GHBP). The results indicated that all AGR feed ingredients appeared to be nutritious since they contained enough concentration of nutrients to cover animal nutritional requirements. Crude protein content varied among the feed ingredients and ranged from 6.53% (CTP) to 19.77% (LMG). Heating treatment, generally, did not affect ($P > 0.05$) all nutrients concentration nor microbiological parameters of all tested feed ingredients. All AGR feed materials were safely fed to animals without any health hazards and compatible to conventional feeds.

11. Edible oils

The fat in mango seed kernel is a promising source of edible oil, Guava (*Psidium guajava* L., Myrtaceae) seeds, usually discarded during processing of juice and pulp, contain 5–13% oil rich in essential fatty acids (Adsule & Kadam 1995). The passion fruit seed oil is rich in unsaturated fatty acids (87.6%) and has free radical scavenging activity (Cassia et al 2012).

12. Pigments

Tomato peel is a rich source of carotenoids such as lycopene (Knoblich et al 2005). It may be beneficial in curing cancer, coronary heart disease and other chronic conditions. The addition of tomato peel to meat products can result in a healthier product due to both the lycopene and fibre present in this by-product of tomato processing. Carrot pomace is also a good source of carotenoids (Zhang & Hamazu, 2004). Anthocyanin pigments in banana bracts (leaves below calyx) and beet root pulp were evaluated for their potential application as natural food colorants.

GENERAL CONSTRAINT ENCOUNTERING UTILIZATION OF AGR

The tremendous increase in the quantum and diversity of waste materials generated by human activities has focused the spotlight on waste disposal methods. Generally, the

greater the economic prosperity and the higher percentage of urban population, the greater the amount of waste produced. Reduction in the volume and mass of wastes is a crucial issue due to limited availability of final disposal sites in almost all parts of the world. There is, no doubt, an obvious need to reduce, reuse and recycle AGR to solve such problems. Several problems that could limit the utilization of AGR such as:

1. Bulkiness of by-products, seasonal availability of AGR and their availability in scattered areas which make its collection and transportation cumbersome.
2. Poor infrastructure and high cost of transportation.
3. Lack of database about quantities seasonality, availability, location, type of AGR and method of utilization and institution involved
4. Lack of research programmes and strategies for utilization of these residues.
5. Lack of experience in a special AGR utilization technology.
6. Lack of cooperation between local institutions and communities in a country on one hand and industry and research base specialized in AGR utilization on other hand.
7. Lack of cooperation between countries which permits transfer of information and technologies from one country to the other.
8. In-adequate national scientific R&D to generate technologies of AGR utilization to be adopted.

PROPOSED STRATEGIES FOR AGR UTILIZATION IN WANA REGION

There is a necessity to work out a strategy at national and regional levels to foster the utilization of AGR and to encourage the collaboration of the leading countries for better utilization. The following elements may help in developing the strategies required:

1. Transfer and implement existing technologies of AGR utilization from leading countries where the technology is established.
2. Strengthening the existing centers in each country to build in scientific and technological capabilities for utilization of AGR through three approaches:
 - a. Dissemination of established technologies among private sector and training concerned personnel in AGR availability and utilization
 - b. Increase public awareness about utilization of AGR handling and utilization.
 - c. Establish web site for AGR production, consumption and utilization.
3. The governments should adopt short, medium and long term policies to ensure sustainability of AGR utilization.
4. Establishment of data base for AGR to compile information on AGR available; quantities, type, seasons and current methods of utilization and disposal, institution involved in R&D and those engaged in implementation.
5. Facing and solving constraints in utilization of AGR in rural areas in the region.

CONCLUSIONS

With urbanization and introduction of modern facilities, agricultural residues start to accumulate beyond the farmer's capacity to be utilized. These residues represent a part of great investments made in agricultural activities, in terms of capital, water and human effort. Agricultural residues should be considered as an additional (secondary) product

of agricultural activity: a wealth of lignocelluloses materials that could provide the material base of a new industrial revolution that could emerge from rural areas in the developing countries, in particular WANA region countries. The rediscovery of agricultural residues as local cheap renewable materials should inspire imagination and innovations for the development of local communities and building of endogenous scientific and technical capabilities along the path of applied research on the industrial use of these materials.

REFERENCES

- Abdel-Maksoud, S. (1999) Economic return of some AGR utilization. In : Sixth Report on Rural development through integrated waste management project.. Soil, Water, and Environment Res. Institute, ARC, Egypt.
- Abo-Hegazi, A. M.T. (2004).Integrated management of an environmental element and beneficial utilization of agricultural plant wastes, Proc. of FAO Expert Consultation on the Utilization of Agricultural Residues. Cairo, Egypt, 6-8 June, 2004, pp. 11-14.
- Adsule, R.N. & Kadam, S.S.(1995). Guava. In D.K. Salunkhe & S.S. Kadam, eds. Handbook of Fruit Science and Technology, pp. 419–433.
- Al Tonobey, H. and El Shaer, H.M. (2010). Utilization of agriculture residues as animal feeds for fattening sheep in Saudi Arabia. In: C.A. Brebbia (ed.),WIT press, The Sustainable World, WIT Transactions on Ecology and the Environment, Vol. 142 : 409- 420.
- Badurdeen, A. L., Ibrahim, M. N. M., Ranawana, S. S. E. 1994. Methods to improve utilisation of rice straw. III. Effect of urea ammonia treatment and urea molasses blocks supplementation on intake, digestibility, rumen and blood parameters. Asian Australian Journal of Animal Sciences. 7 (3), 363-372.
- Ben Salem H., Nefzaoui, A. 2003. Feed blocks s alternative feed supplements for sheep and goats. Small Ruminant Research 49, 275-288.
- Cassia Roberta Malacrida & Neuza Jorge. 2012. Yellow passion fruit seed oil (Passiflora edulis f. flavicarpa): physical and chemical characteristics. Brazilian Archives of Biology and Technology, 55 no. 1.
- Dhabekar, A. & Chandak, A. 2010. Utilization of banana peels and beet waste for alcohol production. Asiatic Journal of Biotechnology Research, 1: 8–13.
- El-Mahdy, L.D., Rezk , L. F. and Nazmy, S. (2004). Silica gel from rice hulls and rice straw ash. Proceedings of FAO Expert Consultation on the Utilization of Agricultural Residues. Cairo, Egypt, 6- 8 June, 2004, pp. 131- 132.
- El- Nawawy, A. (1998). Utilization of mushroom spent compost. FAO-RNEI/ UNESCO/ARC Regional training course on mushroom production, Cairo , Egypt, 15-19 November, 1998.
- El Shaer, H.M. 2004. Utilization of agriculture residues for animal feed. Proceedings of FAO Expert Consultation on the Utilization of Agricultural Residues. Cairo, Egypt, 6- 8 June, 2004, pp. 15 -28, 2004.

- El Shaer, H.M. (1994). Renewable resources for energy and feed supplements from animal wastes." Final Report ". N A R P – USAID Project No. B.1.17, Cairo, Egypt.
- El Shaer, H.M., Salem, O.A. and Khamis, H.S. (1992). Fattening sheep on diets of the broiler litter ensiled with green berseem (*Trifolium alexandrinum*, L). 2- Animal performance and carcass traits. Egyptian J. Anim. Prod. 29 : 263- 272.
- El-Shimi, S.A., El – Housini, M, Ali, B, El – Shinnawi, M.M. (1992). Biogas generation from food processing wastes, journal of resource conservation, and recycling, vol.6.
- FAO/ RNE (2007). Utilization of agricultural residues - Emphasis on biofuels. Proceedings of the 2nd consultation Cairo, Egypt, 29 October - 1 November 2007. ISPN 978-92- 5- 106203- 6 (FAO, 2009).
- Gomaa, H. (2004). Charcoal production from agriculture residues (Egypt). Proceedings of FAO Expert Consultation on the Utilization of Agricultural Residues. Cairo, Egypt, 6- 8 June, 2004, pp. 79 - 98.
- Gomaa, H., Abdul Hameed, E & Naiema Awad (1998). Economic and environmental impacts of cotton stalks briquetting in Egypt. Afro-Asian Fourth Conference for Energy/ Cairo/ December 12th-15th, 1998.
- Hamdi, Y. A. (2004). An overview of organic agriculture. Proc. of FAO Expert Consultation on the Utilization of Agricultural Residues. Cairo, Egypt, 6- 8 June, 2004, pp. 29 -44.
- Hamdi, Y & Wafaa M. Amer ,(2007). Bio-ethanol from Cellulose: An Egyptian vision. Proceedings of FAO Expert Consultation on the Utilization of Agricultural Residues. Cairo, Egypt, 29 Oct.- 1 Nove. 2007, pp. 1-10.
- Hassan , F.R.H. (2000). Studies on the bioconversion of some agricultural wastes using Pleurotus and Agaricus mushrooms. Ph.D Thesis, Fac. of Agric., Cairo Univ., Egypt.
- Kakkar, V. K., Sukhvir, K.(1993). The value of urea molasses liquid diets in ruminants. Agricultural Revue 14 (2), 109-120.
- Knoblich, M., Anderson, B. & Latshaw, D. (2005). Analysis of tomato peel and seed byproducts and their use as a source of carotenoids. Journal of the Science of Food and Agriculture, 85: 1166–1170.
- Salman, A.(2004). New Approach in Development of Feed Blocks Technology in the WANA Region. Proceedings of FAO Expert Consultation on the Utilization of Agricultural Residues. Cairo, Egypt, 6- 8 June, 2004, pp. 57 - 78.
- Sadik M.W, El Shaer, H.M. and Yakot, H.H. (2010). Recycling of Agriculture and Animal Farm Wastes into Compost Using Compost Activator in Saudi Arabia. J. Int. Environmental Application & Science, Vol. 5 (3): 397- 403.
- Sansoucy, R.(1986). Manufacture of molasses-urea blocks. World Animal Revue 57: 40-48.

- Sudana, I. B., Leng, R. A. (1986). Effect of supplementing a wheat straw diet with urea or urea-molasses block and/or cotton seed meal on intake and live-weight change of lambs. *Animal Feed Science and Technology* 16, 25-35.
- Tahir, A. & Sarwar, S. (2012). Effect of cultural condition on production of ethanol from rotten apple waste by *Saccharomyces cerevisiae* straining. *Canadian Journal of Applied Science*,2: 187–195.
- Tits, M., Elsen, A., Bries, J. & Vandendriessche, H.(2012). Short-term and long-term effects of vegetable, fruit and garden waste compost applications in an arable crop rotation in Flanders. *Plant and Soil*, DOI 10.1007/s11104-012-1318-0.
- Wadhwa, M., Bakshi M. P. S. and Makkar H. P.S. (2013). In: Utilization of fruit and vegetable wastes as livestock feed and as substrates for generation of other value-added products. ISBN 978-92-5-107631-6(print)-RAP Publication 2013/04, FAO.
- Zhang, D. & Hamauzu, Y. (2004). Phenolic compounds and their antioxidant properties in different tissues of carrots. *Food Agriculture and Environment*, 2: 95–100.

IMPLEMENTATION OF GREEN AGRICULTURE TECHNOLOGY FOR REDUCING CVPD INCIDENCE

Mofit Eko Poerwanto^{1*}

¹ Department of Agro-technology, Faculty of Agriculture
Universitas Pembangunan Nasional "Veteran" Yogyakarta
Jl. SWK 104 Condong Catur Yogyakarta, Indonesia, 55285

* Corresponding author: mofit.eko@upnyk.ac.id

ABSTRACT

Indonesia is the world citrus producer with more than two hundreds varieties of citrus. Most of citrus orchards have been destroyed by Citrus vein phloem degeneration (CVPD). CVPD is the most impediment disease in citrus production in the world. It mainly vectored by *Diaphorina citri* Kuwayama. Intensive application of insecticides was ineffective and also costly. Comprehensive strategy for reducing CVPD is being conducted and evaluated by the integration of planting disease free trees, and controlling disease vector (*D. citri*). The vector control consists of guava intercropping, alternative host sanitation, planting area isolation, and mineral oil application. The strategy would decrease the infection of CVPD by reducing the inoculum titer, eliminating contacts between disease inoculum with the vector, and decreasing infective vector population.

Keywords: Citrus, disease free trees, *D. citri*, guava intercropping, mineral oils

INTRUDUCTION

Indonesia is currently the second world citrus producer after China with more than 210 varieties of citrus. The citrus production in 1995 was 143,059 ton, and it decreased to 91,469 ton in 1996. The production increased into 696,422 ton in 1997 and decreased sharply into 449, 552 ton in 1999. Recently, citrus production in Indonesia has developed rapidly. In 2007, the production increased to 2,625,884 ton. In 2008, the production decreased again into 2,467,632 ton and in 2010 were 2,032,665 ton due to the orchard extension. However, the production dropped again into 1,611,784 ton in 2012 (BPS, 2013). Fluctuation on citrus production was mainly caused by Citrus vein phloem degeneration (CVPD). The disease caused 50 million citrus trees lost both in South Asia and South East Asia (Gonzales, 1987). CVPD was first reported in Indonesia in 1964 (Semangun, 1991). Severe epidemics of the disease occurred in the 1960s, especially in Java and Sumatera where at least 3 million trees were destroyed. It was informed that the disease has destroyed 9 million out of 42.8 million total citrus-trees in Indonesia in 1990, with economic loss was about 35 billion rupiah per year (Nurhadi, 1991). Many highly productive plantations where yields were 20 ton per ha decreased sharply into 8.6-15 ton per ha per annum (Irawan *et al.*, 2003). A citrus rehabilitation program based on the synthetic pesticide approach to eradicate vector and disease was initiated in the

mid 1980s. However, the citrus trees in Indonesia have not been free of CVPD (Bove *et al.*, 2006). CVPD continues to be the major impediment to citriculture in Indonesia. Currently, green agriculture approach started to be applied to reduce CVPD incident instead of synthetic pesticide. Green agriculture is agricultural practices that are involved the “green technology” in the production. It is considering of biological diversity; is keeping harmony and unity of nature and economy during the course of agricultural development; and is producing of pollution-free and nuisance-free products (Zhongdong, 2002).

A. CVPD

CVPD, also recognised as Huanglongbing or greening disease, was firstly found and produced a serious problem in the Chaozhou/Shantou region of Guangdong in the mid 1930s (Lin, 1956). The disease epidemic was found in some Asian countries (Tirtawidjaja *et al.*, 1965; Garnier & Bové, 2000; Weinert *et al.*, 2004), and in the Arabian Peninsula (Bové & Garnier, 1984). It was also found in Africa, Mauritius and Réunion (Garnier *et al.*, 1996), United States of America (Florida and Louisiana), Cuba (Martínez *et al.*, 2008), and Brazil (Teixeira *et al.*, 2005).

At the initial stage trees develop mottle leaves in one or few branches similar to that caused by the lack of zinc (Dwiastuti *et al.*, 2003). Leaves become smaller and bunchy. The fruits become bitter and sour and the sugar concentration decreases. CVPD agent is a fastidious or unculturable Gram-negative bacterium with the proposed name ‘*Liberibacter asiaticus*’ and ‘*Liberibacter africanus*’ for Asian and African types, respectively (Nakashima *et al.*, 1998). The latent period in citrus plants before symptoms is expressed ranges from four months to one year or more. Once the citrus plant has been infected, it will die in two to four years (Su & Huang, 1990).

CVPD is not transmitted by seeds, but is naturally transmitted through vegetative propagation and by insect vector (Subandiyah *et al.*, 2000). ‘*Candidatus L. africanus*’ is transmitted by insect vector of *Trypiza erythrae* while ‘*Candidatus L. asiaticus*’ and ‘*Candidatus L. americanus*’ are transmitted by *D. citri* (Bove, 2006). Only adult psyllids and the 4-5th instar nymphs are able to acquire the pathogen (Capoor *et al.*, 1974; Xu *et al.*, 1988). Once the psyllid vector acquires the pathogens, it can transmit them throughout its life span. However, it cannot transfer the virulence to its progeny via eggs (Xu *et al.*, 1991; Hung *et al.*, 2004).

B. Control Strategy

The impact of citrus production intensification has led to heavy use of pesticides for reducing pest populations, and spread of the pest-carrying pathogens. Most emphasis has been placed on contact and systemic synthetic insecticides to kill insect pest eggs, nymphs or adults, but use of these and other chemicals merely slow inevitable death of trees from the pest and disease attack. The negative side-effects relating to the use of synthetic chemicals include the destruction of predators and parasitoids, rapid development of resistance to insecticides, resurgences in pest densities, and risks to farm workers and environmental quality (Westigard *et al.*, 1986). The systemic insecticide, imidacloprid, is effectively controlled the pest, however the whole part of plant will contaminated by its active ingredient (Mendel *et al.*, 2000). Infected adult

psyllids can also transmit the pathogen while acquiring lethal doses of insecticide (Beattie & Barkley, 2009). Very limited emphasis has been placed on strategies to reduce feeding, oviposition and ingress of psyllids into orchards by altering the behaviour of adults. Integrated strategy for controlling CVPD can be developed by using disease free trees, mineral oil application, guava intercropping, alternative host sanitation, and planting area isolation. It also contributed in reducing highly poisoned pesticides contamination in ecosystem, especially in the area of citrus orchards.

1. Disease free trees

Citrus plants that are free from CVPD are the main materials for combating CVPD infection in new citrus orchard. The main source of grafting materials of Indonesian citrus is at Tlekung. Varieties are cleaned-up using standard Shoot Tip Grafting (STG) techniques and regrafted to produce Foundation Blocks (FB) as the primary sources of budwood. Confirmation of CVPD infection is regularly conducted. The system for the distribution of virus-free budwood and stocks for FBs to the grower is so long that risks of reinfection cannot be avoided. Phytosanitary quality in the citrus nursery is the crucial and critical part in supplying CVPD free trees (Supriyanto & Whittle, 1991). The citrus orchard will be kept free from CVPD infection by the lack of its inoculums. Characteristic symptom of CVPD infection was found 29 months after planting of CVPD free trees. It was due to the infestation of its vector nine months before (Poerwanto, 2010).

2. Planting area isolation

It had been reported that plant odours (volatile) vary substantially, depending on species, cultivar, growing conditions, age and plant parts (Takabayashi *et al.*, 1994), and it plays an important role in host plant selection by herbivorous insects (Bichao *et al.*, 2005). Establishing new citrus orchard in the isolated area will delay the *D. citri* infestation and CVPD infection. It takes longer time for citrus plant odours to be detected by *D. citri* and attract its colony to infest. Initial colony of *D. citri* was found 20 months after planting at new citrus orchard in an isolated area, far from the established citrus orchard and was surrounded by paddy's field. Five months more was needed for the colony of *D. citri* to colonized 100% citrus plants in one block. The colonization of *D. citri* in other blocks started from one plant spread to other plants at the same block before migrating to other nearby blocks (Poerwanto, 2010). The spread is very slow because the flight ability of psyllid is limited to 0.5-2 km when searching for a host; dispersal over 90 km is, or may be, possible in strong winds, such as those associated with cyclones (Halbert *et al.*, 2008).

3. Alternative host sanitation

The hosts of CVPD agent are not only citrus, but also *Catharanthus roseus* (periwinkle), *Cuscuta campestris* and ornamental plants, such as orange jasmine (*Murraya exotica*, *Murraya paniculata*) also. *D. citri* colonies are also found on *Murraya paniculata*, *Murraya exotica*, and *Berberis koenigii* all year round (Tsai *et al.*, 2002). Four of 16 species of weeds in citrus orchards are able to be the alternative host.

There are *Alternanthera philoeroides*, *Amaranthus spinosus*, *Ludwigia perrenis*, and *Boerhavia erecta* (Hardiastuti & Poerwanto, 2011).

D. citri was able to survive a maximum of eight days with the mean longevity of 5.91 ± 0.251 days on the broadleaf weed *B. erecta*, but was not able to complete one life cycle. The ability to survive in non host plants indicated the existence of nutrients content in the weed that resembles its host plant nutrient content or the existence of certain substances that could stimulate *D. citri* to stay for feeding (Hardiastuti & Poerwanto, 2011). The substances could be a various compounds of alcohol and aldehyde from the leaves of which were specific and volatile used by insect to find its host plant (Visser, 1986). However, the type and number of nutrient content was not as complete as in the host plant for surviving and completing its life cycle. Similar results were also obtained by Sudiono and Purnomo (2008) in Gemini virus insect vectors (*Bemecia tabaci*), and Hardiastono (2001) on Peanut Stripe Virus (PStV). *B. tabaci* were able to live on broadleaf weed *Ageratum conyzoides*. The weeds also serve as a source of inoculum since they were able to be infected by Gemini virus.

The implications of those survivorships of *D. citri* in ornamental plants and some weed species is the presence of alternative host for *D. citri* when citrus plant is not available as a food source, either because there are no plants or when plants are treated with pesticides. The existence of alternative host will cause the population of *D. citri* is available throughout the season and serve as initial population for the next generation population. The role of *D. citri* as a propagative vector of CVPD pathogen will also make the disease inoculums always available throughout the season in field (Hardiastuti and Poerwanto, 2011). Alternative host sanitation could be an effective control measures against CVPD on citrus plant, since the disease transmission is highly dependent on the availability of disease inoculums and insect vector population in the field.

4. Guava intercropping

Based on observations by Vietnamese ACIAR researcher team, it is suggested that citrus groves intercropped with guava trees was free from *D. citri* invasion and low incidence of CVPD-infected trees (Beattie *et al.*, 2006). Certain volatile compounds in guava leaf could be developed as repellents for citrus psylla. Guava fruits and leaves produce a wide range of volatile compounds, such as sesquiterpenes (Sagrero-Nieves *et al.*, 1994; Ogunwande *et al.*, 2003), aldehydes and alcohols (Idstein & Schreier, 1985; Begum *et al.*, 2004; Soares *et al.*, 2007). Some of these aldehydes and alcohols are the so called 'green leaf volatiles' that have been shown to have repellent effects on insects (Jang & Light, 1991).

The present study revealed that the repellent action of guava against citrus psylla is dose-dependent, with very low doses having little effect on citrus psylla. This result indicates that to control citrus CVPD by intercropped guava trees in citrus groves, sufficient numbers of guava trees are needed to keep the dosage of volatile compounds emitted from guava at an effective level in the entire grove (Zaka, *et al.* 2010). In China, observations revealed that even in the presence of guava trees scattered inside or around the groves, citrus psylla populations are high. This could be due to the fact that the guava trees present did not release enough active volatile compounds (Beattie *et al.*, 2006). Intercropping guava among the young citrus plants with ratio of guava: citrus

population is 1:8, resulted no *D. citri* population and CVPD symptom found in the orchard, whilst CVPD symptoms (was confirmed with PCR) and 0.4 imago of *D. citri* with 0.3 nymph colony and 0.1 egg colony per plant were found in the orchard 100-1000 meters apart away planted of 50-200 citrus trees of 3-6 years old (Pustika *et al.* 2008). In Vietnam, it was suggested that guava trees are intercropped prior to citrus at a ratio of one guava tree to one citrus tree (Beattie *et al.*, 2006).

5. Oils application

Taverner (2002) has reviewed the toxic effects of mineral oils and listed several routes of potential mortality with mineral oils usage in addition to smothering effects. They included: fumigant action, narcosis, nervous disruption, corrosion of insect tissues, cell disruption, and desiccation. Two recurring themes are evident in the literature regarding the use of petroleum-derived spray oils in integrated pest and disease management programs. First, a mineral oil is non-selective but has short residual activity. Those mineral oils are less phytotoxic to the plant and do not induce any carcinogenic effect to human (Beattie, 2010; personal communication). Second, a mineral oil gives minimal disruption of beneficials (Childers, 2002). A third, and very important benefit of using mineral oils, is that no arthropod resistance development is known with the use of petroleum oil spray applications.

Mineral oils are highly refined mineral oils derived from crude petroleum oils. They are paraffinic ($\geq 60\%$ of carbon atoms occur in chains). Horticultural Mineral Oils (HMOs) are called narrow-range petroleum spray oils and Agricultural Mineral Oils (AMOs) are called broad-range petroleum spray oils. Common median *n*Cy values of HMOs are *n*C21 and *n*C23. For AMOs they are *n*C23, *n*C24 and *n*C25 (Agnello, 2002; Beattie, 2009).

Oils have behavioural effects on insect pest. The use of oils was effectively reduced pest population as oviposition and feeding deterrence. The oil film could provide a barrier by physical disruption of epicuticular lipids and masking of feeding and oviposition stimulants preventing the insect from locating, accepting or using the host plant. Application of mineral oils could also increase the release of volatiles which were used as olfactory cues. The volatiles were naturally released in response to feeding by herbivorous insect (Xue *et al.*, 2009).

Application of oils for citrus pests is ranged from 0.4% to 0.5% sprays at 5-14 day intervals within flush cycles (Poerwanto *et al.*, 2008, 2010). They reduced 56.7% - 61.3% proportions of psyllids attracted to citrus (Poerwanto *et al.*, 2008). *D. citri* gravid female rejected to lay their eggs on citrus treated with mineral oils (Rae *et al.*, 1997). Responses of adult *D. citri* to mineral oil deposits are olfactory and related to detection by antennal receptors of oil volatiles and/or plant volatiles (Poerwanto *et al.*, 2012). This outcome indicates that application of the oils to the mandarin leaves may have: (a) suppressed release of attractant host plant volatiles; (b) masked attractant host plant volatiles; (c) led to the release of repellent volatiles from leaves; and/or (d) to adults being repelled by oil volatiles (Poerwanto *et al.*, 2008; 2012). Oils application also attract parasitoid (Poerwanto & Brotodjojo, 2011) and predator insect (Poerwanto, 2010) giving multiple control measure to *D. citri*.

CONCLUSION

CVPD incidence reduction should be comprehensively conducted by implementing green agriculture technology instead of synthetic pesticide. It should be started by seeking new area for establishing citrus orchard. The area should be far enough from citrus orchard and free from alternative hosts of CVPD and its vector. Second step is interplanting guava among citrus plants followed by using mineral oils when the vector colony was found. Last but not least is keeping the orchard always clean of weeds which could be used as alternative host by vector.

ACKNOWLEDGMENTS

I gratefully acknowledge the Australian Centre for International Agricultural Research, Horticultural Research (ACIAR HORT/02/043), Directorate of Higher Education Ministry of Education and Culture, and LPPM UPN “Veteran” Yogyakarta for financial support.

REFERENCES

- Agnello AM. 2002. Petroleum-derived spray oils: chemistry, history, refining and formulation. *In* Beattie, GAC., Watson, DM., Stevens, ML., Rae and Spooner-Hart eds. Spray oils beyond 2000 sustainable pest and disease management. University of Western Sydney. pp.2-18.
- Beattie G.A.C., Holford P., Mabblerley D.J., Haigh A.M., Bayer R. and Broadbent P. (2006) Aspects and insights of Australia–Asia collaborative research on huanglongbing. Proceedings of an International Workshop for Prevention of Citrus Greening Diseases in Severely Infested Areas, 7–9 December 2006, Ishigaki, Japan (Multilateral Research Network for Food and Agricultural Safety. Japanese Ministry of Agriculture, Forestry and Fisheries; Tokyo, Japan). pp. 47–64.
- Beattie GAC. 2009. Plant protection 300643 (HT 301A). Biorational chemicals: Use of mineral oils in citrus and rose IPDM. Centre for plants and the environment. University of Western Sydney.
- Beattie GAC., Barkley P. 2009. Huanglongbing and its vectors: A pest-specific contingency plan for the citrus and nursery and garden industries (Version 2), February 2009. Sydney: Horticulture Australia Ltd. 272 pp.
- Begum, S., Hassan, S.I., Ali, S.N. and Siddiqui, B.S. (2004) Chemical constituents from the leaves of *Pisidium guajava*. *Natural Product Research*, 18, 135–140.
- Bichao H, Borg-Karlson AK, Araujo J, Mustaparta H. 2005. Five types of olfactory receptor neurons in the strawberry blossom weevil *Anthonomus rubi*: selective responses to inducible host-plant volatiles. *Chemical Senses*. 30: 153-170
- Bové JM. 2006. Huanglongbing: a destructive, newly-emerging, century-old disease of citrus. *Journal of Plant Pathology*. 88, 7-37.

- BPS. 2013. Fruits production in Indonesia, 1995 - 2012. http://www.bps.go.id/tab_sub/view.php?kat=3&tabel=1&daftar=1&id_subyek=55¬ab=5 . Accessed October 2013. In bahasa
- Capoor SP, Rao DG, Viswanath SM. 1974. Greening disease of citrus in the Deccan Trap country and its relationship with the vector *Diaphorina citri* Kuwayama. *In*: Weathers LG, Cohen M (eds), Proceedings of the Sixth Conference of the International Organization of Citrus Virologists, Mbabane, Swaziland, 21-28 August 1972. Richmond: University of California, Division of Agricultural Sciences. pp. 43-49.
- Childers, C. C. 2002. Practical use of horticultural mineral oils in integrated pest and disease management programs and their impact on natural enemies. *In* Beattie, GAC., Watson, DM., Stevens, ML., Rae and Spooner-Hart eds. Spray oils beyond 2000 sustainable pest and disease management. University of Western Sydney. pp. 332-348.
- Dwiasuti ME, Triwiratno A, Suhariyono. 2003. Introduction of CVPD on citrus. Citrusindo Citrus Indonesia. Lolit Jeruk Vol 3. In bahasa
- Garnier M, Bové JM. 2000. Huanglongbing in Cambodia, Laos and Myanmar. *In*: da Graça JV, Lee RF, Yokomi RK (eds), Proceedings of the Fourteenth Conference of the International Organization of Citrus Virologists, Campinas, Sao Paulo, Brazil, 13-18 September 1998. Riverside: International Organization of Citrus Virologists, University of California: Riverside. pp. 378-380.
- Garnier M, Jagoueix S, Toorawa P, Grisoni M, Mallessard R, Dookun A, Saumtally S, Autrey JC, Bové JM. 1996. Both huanglongbing (greening) liberobacter species are present in Mauritius and Reunion. *In*: da Graça JV, Moreno P, Yokomi RK (eds), Proceedings of the Thirteenth Conference of the International Organization of Citrus Virologists, Fuzhou, Fujian, China, 16-23 November 1995. Riverside: International Organization of Citrus Virologists, University of California, Riverside. pp. 392-394.
- Gonzales CI. 1987. Symptoms of leaf mottling disease on Phillipine citrus cultivars. Regional Workshop on Citrus Greening huanglongbing disease Held in China with the cooperation of the Fujian Academy of Agricultural Sciences and the Ministry of Agriculture Beijing.
- Halbert S, Manjunath K, Roka F, Brodie M. 2008. Huanglongbing (citrus greening) in Florida, 2008. *In*: Ku TY, Pham THH (eds), Proceedings of FFTC-PPRI-NIFTS Joint Workshop on Management of Citrus Greening and Virus Diseases for the Rehabilitation of Citrus Industry in the ASPAC, Plant Protection Research Institute, Hà Nội, Việt Nam, 8-12 September 2008. pp. 58-67.

- Hardiastono T. 2001. The Potency of broad leaf weeds of peanut (*Arachis hypogaea* L.) as alternative hosts of peanut stripe virus (PStV). *Habitat*. 12: 139-146. In bahasa
- Hardiastuti S, Poerwanto ME. 2010. Preference of CVPD vector (*Diaphorina citri*) on various citrus dominant weeds. Prosiding Seminar nasional ketahanan pangan dan energi. Yogyakarta 2 Desember 2010. III51-54. In bahasa
- Hung TH, Hung SC, Chen C, Hsu MH, Su HJ. 2004. Detection by PCR of *Candidatus Liberibacter asiaticus*, the bacterium causing citrus huanglongbing in vector psyllids: application to the study of vector-pathogen relationships. *Plant Pathology* 53: 96-102.
- Idstein, H. and Schreier, P. (1985) Volatile constituents from guava (*Psidium guajava* L.) fruit. *Journal of Agricultural and Food Chemistry*, 33, 138–143.
- Irawan IGP, Sulistyowati L, Wijaya IN. 2003. CVPD disease in citrus plant (biotechnology base analysis). Dirjen Perlindungan Hortikultura.
- Jang, E.B. and Light, D.M. (1991) Behavioral responses of female oriental fruit flies to the odor of papayas at three ripeness stages in a laboratory flight tunnel (Diptera: Tephritidae). *Journal of Insect Behaviour*, 4, 751–762.
- Martínez Y, Llauger R, Batista L, Luis M, Iglesia A, Collazo C, Peña I, Casín JC, Cueto J, Tablada LM. 2008. First report of *Candidatus 'Liberibacter asiaticus'* associated with huanglongbing in Cuba. *New Disease Reports*. <http://www.bspp.org.uk/ndr/jan2009/2008-50.asp>.
- Mendel, RM., Bayer, UR. Fuhr, F. 2000. Xylem transport of the pesticide imidacloprid in citrus. *Proceeding of second conference of subtropical fruits ISHS*. M. Blanke & J. Pohlen (eds).
- Nakashima K, Ohitsu Y, Prommintara M. 1998. Detection of Citrus Organism in Citrus Plants and Psylla *Diaphorina citri* in Thailand. *Annals of the Phytopathological Society of Japan*. 64: 153-159.
- Nurhadi. 1991. Status of some pests of sweet orange and mandarin orange. *Jurnal Hortikultura*. 1: 49-56. In bahasa
- Ogunwande, I.A., Olawore, N.O., Adeleke, K.A., Ekundayo, O. and Koenig, W.A. (2003) Chemical composition of the leaf volatile oil of *Psidium guajava* L. growing in Nigeria. *Flavour and Fragrance Journal*, 8, 36–138.
- Poerwanto ME, Trisyono YA, Subandiyah S, Martono E, Holford P, Beattie GAC. 2008. Effect of mineral oils on host selection behaviour of *Diaphorina citri*. *Indonesian Journal of Plant Protection*. 14: 23-28.
- Poerwanto ME, Trisyono YA, Subandiyah S, Martono E, Holford P, Beattie GAC. 2012. Olfactory Responses of the Asiatic Citrus Psyllid (*Diaphorina citri*) to Mineral Oil-Treated Mandarin Leaves. *American Journal of Agricultural and Biological Sciences* 7 (1): 50-55
- Poerwanto ME. 2010. The impact of mineral oils to the feeding and oviposition behaviour of *Diaphorina citri* Kuwayama. *Disertation*. Gadjah Mada University. 110 pp.

- Poerwanto, ME., Brotodjojo, RR. 2011. Response of generalist parasitoid *Trichogramma japonicum* toward citrus leaves volatile. Prosiding strategi reduksi dan adaptasi perubahan iklim dalam bidang pertanian. Yogyakarta 29 Oktober 2011. 19-28. In bahasa
- Pustika AB, Poerwanto ME, Subandiyah S, & Beattie GAC. 2008. *Diaphorina citri* and CVPD incidence on citrus intercropping with guava. Prosiding Seminar jeruk 2007. Yogyakarta 13-14 Juni 2007. 371-376. In bahasa
- Rae Dj, Liang WG, Watson DM, Beattie GAC, Huang MD. 1997. Evaluation of petroleum spray oils for control of the Asian citrus psylla, *Diaphorina citri* Kuwayama (Hemiptera: Psyllidae) in China. International Journal of Pest Management. 43: 71-75.
- Sagrero-Nieves, L., Bartley, J.P. and Provis-Schwede, A. (1994) Supercritical fluid extraction of the volatile components from the leaves of *Psidium guajava* L. (guava). Flavour and Fragrance Journal, 9, 135–137.
- Semangun H. 1991. Horticultural diseases in Indonesia. Gadjah Mada Univ Press. 666 p. In bahasa
- Soares, F.D., Pereira, T., Marques, M.O.M. and Monteiro, A.R. (2007) Volatile and non-volatile composition of the white guava fruit (*Psidium guajava*) at different stages of maturity. Food Chemistry, 100, 15–21.
- Su HJ, AL, Huang. 1990. The Nature of Likubin Organism, Life Cycle, Morphology and Possible Strains. Proc. 4th Conf. UN Devel. Prog. Food Agric. Org. Regional Project for Citrus Greening Control. 106-110.
- Subandiyah S, Iwanami T, Tsuyumu S, Ieki H. 2000. Comparison of 16S rDNA and 16S/23S intergenic region sequences among citrus greening organisms in Asia. Plant Disease. 84:15-18.
- Sudiono, Purnomo. 2008. Hosts study of *Bemisia tabaci* Genn. in vegetable production center tanggamus. Jurnal Penelitian Terapan. 8: 103-108. In bahasa
- Supriyanto, A., Whittle, AM. 1991. Citrus rehabilitation in Indonesia. Proceeding of Eleventh IOCV Conference. Riverside CA. 409-413
- Takabayashi J, Dicke M, Posthumus MA. 1994. Volatile herbivore-induced terpenoids in plant-mite interactions: variation caused by biotic and abiotic factors. Journal of Chemical Ecology 20: 1329-1354
- Taverner, P. 2002. Drowning or just waving? A perspective on the ways petroleum-derived oils kill arthropod pests of plants. In Beattie, GAC., Watson, DM., Stevens, ML., Rae and Spooner-Hart eds. Spray oils beyond 2000 sustainable pest and disease management. University of Western Sydney. pp. 78-87.
- Teixeira, DC, Ayers J, Danet L, Jagoueix-Eveillard S, Saillard C, Bové JM. 2005. First report of a huanglongbing-like disease of citrus in São Paulo State, Brazil and association of a new *Liberibacter* species, '*Candidatus* *Liberibacter americanus*', with the disease. Plant Disease 89: 107.
- Tirtawidjaja S, Hadiwidjaja T, Lasheen AM. 1965. Citrus vein-phloem degeneration virus, a possible cause of citrus chlorosis in Java. Proceedings of the American Society of Horticultural Science 86: 235–243.

- Tsai JH, Wang JJ, Liu YH. 2002. Seasonal abundance of the asian citrus psyllid, *Diaphorina citri* (Homoptera: psyllidae) in southern florida. Florida Entomol. 85: 446-451.
- Visser JH. 1986. Host odour perception in herbivores insects. Annual Reviews of Entomology. 31, 121-144
- Weinert MP, Jacobson SC, Grimshaw JF, Bellis GA, Stephens PM, Gunua TG, Kame MF, Davis RI. 2004. Detection of huanglongbing (citrus greening disease) in Timor Leste (East Timor) and in Papua New Guinea. Australasian Plant Pathology 33: 135-136.
- Westigard PH, Gut LJ, Liss WJ. 1986. Selective control program for the pear pests complex in southern Oregon. Journal of Economic Entomology. 79: 250-257.
- Xu CF, Wang DX, Ke C. 1991. A report of implementation of integrated control of citrus huanglungbin, aiming at renovating old infected orchard in epidemic zone and protecting new noninfected orchard in non-epidemic zone. *In*: Ke C, Osman SB (eds), Proceedings of the Sixth International Asia Pacific Workshop on Integrated Citrus Health Management, Kuala Lumpur, Malaysia, 24–30 June 1991. pp. 55-61.
- Xu CF, Xia YH, Li KB, Ke C. 1988. Studies on the law of transmission of citrus huanglungbin by psyllid, *Diaphorina citri* and the distribution of the pathogen. Journal of the Fujian Academy of Agricultural Science 3(2): 57-62.
- Xue, Y., Beattie, GAC., Meats, A, Spooner-Hart, Herron, GA. 2009. Relative toxicity of nC24 agricultural mineral oil to *Tetranychus urticae* Koch (Acari: Tetranychidae) and *Phytoseiulus persimilis* Athias-Henriot (Acari: Phytoseiidae) and its possible relationship to egg ultrastructureae. Australian Journal of Entomology 48, 251–257
- Zaka SM, Zeng XN, Holford P, Beattie GAC. 2010. Repellent effect of guava leaf volatiles on settlement of adults of citrus psylla, *Diaphorina citri* Kuwayama, on citrus. Insect Science. 17: 39-45
- Zhongdong, WU. 2002. Study on china green agriculture development strategy. <http://www.seiofbluemountain.com/upload/product/201010/2010dthy01a14.pdf>. Accessed October 2013

MICRO, SMALL AND MEDIUM-SIZED ENTERPRISES OF BANANA'S VARIETY PRODUCTS TO SUPPORT THE GREEN AGRO - INDUSTRY

Heni Handri Utami¹⁾ and Siti Hamidah¹⁾

¹⁾ Study Program of Agribisnis Faculty of Agriculture UPN "Veteran" Yogyakarta

Email: henihandri@yahoo.com and shamidah81@yahoo.co.id

ABSTRACT

In Indonesia SMEs are the backbone of the Indonesian economy, and they are about 52 million by 2011. SMEs contribute for 60% of GDP and absorb 97% of the labor force. The improvement of SMEs is based on the development of natural resources and human resources at the SMEs location. In Indonesia bananas are always available throughout the year and can be planted around the house where the SMEs do the activity, or cultivated commercially in the form of a banana plantation. SMEs that produce processed banana is developed towards zero waste technique, it means all parts of the plant are used to be processed into useful products. This will support green agro-industry. All parts of the banana plant, the cups, the stems, the leaves, the flowers and the fruits can be processed into various products. Banana cups can be processed into crackers. Rods can be processed into banana crackers, chips and shredded. While the flowers can be processed into banana chips, banana shredded and "rendang" (a spicy dish). Banana leaves can be used as food wrapping. The untreated residue will be processed for organic fertilizer. The SMEs that produces those processed bananas is supporting green agro-industry.

Keywords: *SMEs, processed banana products, green agro-industry*

INTRODUCTION

Besides as supporting commodity of food stability, bananas in Indonesia also have a potential to be agro-business commodity. This potential is described through its highest total plantation area and production compared to any other fruit in Indonesia, and it also provides 50% of total national food production (Anonymous, 2002). Bananas are available throughout the year so that the production continuity with the raw material of bananas is more secured. Industry in agro-business sector usually faces a problem of raw material supply continuity. As we know that agricultural products cannot stay fresh for a long duration (vulnerable). Thus, it should open up the business opportunity for the creative community.

Besides can be consumed as a fresh fruit, bananas can also be processed either for home industry such as chips, *getuk*, and *sale*, or giant industry such as flour, puree, and jam, that can stimulate the growth of downstream agro-business. Downstream agro-business will be developed by empowering home industry and medium or large-sized industry

(domestic and foreign investor). For years, people just make use of banana fruit. With a little bit of creativity and a touch of precise technology, every part of the banana plant from its pseudo-stem, its inflorescence, its corm, its leaf, and even its peel can be processed into various banana products that have economic value, so that all parts of banana plant can be utilized.

A. Banana's Variety Products

All parts of the banana plant, the cups, the stems, the leaves, the flowers and the fruits can be processed into various products.

1. Banana fruit is usually consumed in the fresh form or simply cooked into fried banana, boiled banana or roasted banana.

One technique to maintain the banana fruit's storability is by a further process. The process will increase the banana fruit's durability, and provide various tastes from the banana product. The banana fruit that is not possible to be served as a fresh fruit because of its small size or flawed peel can still be processed into various products which have delicious tastes and appealing looks.

- a. Raw banana fruit can be processed into: Flour, Starch, Chips, and Sauce/Chili Sauce
Banana flour is a product which has a good business opportunity in the development of local food resources. Banana fruit is good to be processed into flour because the main component of banana fruit is carbohydrate (around 17.2 – 38%). Basically, all types of raw banana fruit can be processed into flour, but the color will be varied depends on the ripe level of the fruit, the fruit type, and the processing method. Banana fruit *kepok* has the best flour color which is white. Banana flour can be a good substitute for wheat flour that can be processed into baby porridge, banana cake, banana eggrolls, etc.
 - b. Ripe banana fruit can be processed into: Fruit Essence, Fruit Syrup, *Sale*, Jam, Wine, Chips, *Dodol*, *Pure*, Jelly, Ice Cream, and Candy.
2. Banana inflorescence, which is only wasted or used as a vegetable combination, can be processed into shredded banana inflorescence and dry banana inflorescence chili sauce
 3. Banana corm, which is never seen as a product, with a precise technology can be processed into banana corm chips.
 4. Banana peel can also be processed into banana crackers, banana peel ice, and banana noodle so that it will have a bigger additional value.
 5. Banana leaf can be used as food layer or food wrapper.
 6. Banana false stem can be used for crafting raw materials such as bag, purse, etc.
 7. The waste from banana plant processing can also be processed into useful product, for example as livestock and fish food, or organic fertilizer. These livestock food

and organic fertilizer can be used for plant, livestock, and fish cultivation business matter.

According to the description about various alternatives of banana plant processing, it can be concluded that all parts of banana plant can be used. So therefore, a diagram that describes the banana plant industry can be figured, see image 1.

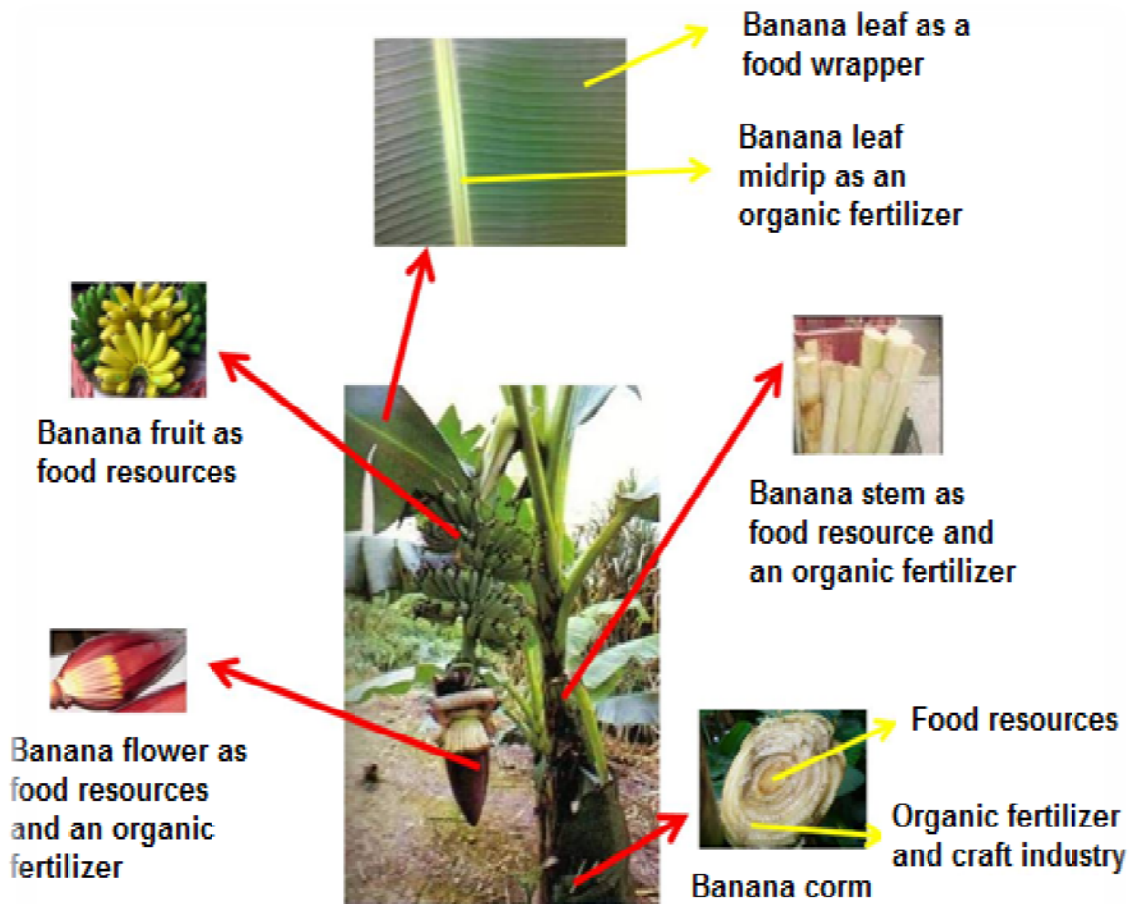

Figure 1. The Banana Plant Industry Diagram

B. Micro, Small And Medium-Sized Enterprises

Either in the developing countries or in the highly developed countries such as in Europe, United States, and Japan, Small and Medium-Sized Enterprise (SME) plays an important role, especially as one of the initiating forces of the economic and export growth, also as an innovation source. In the beginning, small and medium-sized enterprise in Indonesia was the important source of working opportunity and the main initiating force in the economic development of rural area, outside agricultural sector. But now, in the era of free trade and the globalization process that is more incentive,

Small and Medium-Sized Enterprise is very much expected to be one of the improvement sources for non-oil and gas export (Tambunan, 2002).

Even in modern economy, SME still has a big opportunity to survive or rapidly grow if the business makes types of product whose production process does not have economic scale and contain a simple technology.

Until the period of 1998, the amount of Small-Sized Agro-Industry Food Processing in Indonesia is 542,441 units, absorbing up to 4,112,129 labor force, with investment value of 2,830,767 million rupiahs, raw material value up to 6,574,637 million rupiahs, and production value of 12,053,950 million rupiahs (Baroroh and Hanafiah, 2004 in Soekartawi, 2005).

In the development, the total amount of Micro, Small and Medium-Sized Enterprise in Indonesia tends to increase, as well as its ability to absorb labor force. The development of micro, small and medium-sized enterprise, also large-sized enterprise in the year of 2011-2012 is shown on table 1.

Table 1. The Development of Micro, Small and Medium-Sized Enterprise and Large-Sized Enterprise in the year of 2011-2012

No	Indicator	Unit	Year 2011*)		Year 2012**)		The development in 2011-2012	
			Amount	Segment (%)	Amount	Segment (%)	Amount	(%)
1	Business Unit (A+B)	unit	55,211,39		56,539,560		1,328,163	2.41
	A. UMKM	unit	55,206,44	99.99	56,534,59	99.99	1,328,147	2.41
	Micro	unit	54,559,96	98.82	55,856,17	98.79	1,296,207	2.38
	Small	unit	602,19	1.09	629,41	1.11	27,223	4.52
	Medium	unit	44,28	0.08	48,99	0.09	4,717	10.65
	B. Large Enterprise	unit	4,95	0.01	4,96	0.01	16	0.32
2	Labor Force (A+B)	person	104,613,68		110,808,15		6,194,473	5.92
	1. UMKM	person	101,722,45	97.24	107,657,50	97.16	5,935,051	5.83
	Micro	person	94,957,79	90.77	99,859,51	90.12	4,901,720	5.16
	Small	person	3,919,99	3.75	4,535,97	4.09	615,977	15.71
	Medium	person	2,844,66	2.72	3,262,02	2.94	417,354	14.67
	2. Large Enterprise	person	2,891,22	2.76	3,150,64	2.84	259,422	8.97

Notice:

*) Temporary Number

***) Prediction Number

Source: Ministry of Cooperative and Micro, Small and Medium-Sized Enterprise, 2012

Micro enterprise places itself in the largest market segment and also in the biggest labor force employment amount among the others. The development of medium-sized

enterprise amount from 2011 until 2012 is high enough, around 10.65%. This describes that Micro, Small and Medium-Sized Enterprise needs to be developed because it can

absorb more labor force and also can give contribution up to 60% from Gross Domestic Product. Hence, the challenge is to integrate the micro and small-sized enterprise so that it can operate more efficiently and continuously, also support the green agro-industry.

In Indonesia SMEs are the backbone of the Indonesian economy, and they are about 52 million by 2011. SMEs contribute for 60% of GDP and absorb 97% of the labor force. The improvement of SMEs is based on the development of natural resources and human resources at the SMEs location. In Indonesia bananas are always available throughout the year and can be planted around the house where the SMEs do the activity, or cultivated commercially in the form of a banana plantation.

According to research conducted by Budiyanto (2012) in Lumajang, Malang, and Blitar showed that: 1) there is profile diversity on the banana production, distribution, consumption, and local wisdom role, 2) the optimization of local wisdom role can be the main focus on the development of banana-based food stability effort, and 3) several important and strategic components in the banana-based food stability development model through revitalization of local wisdom value and farmer community department strengthening are: a) the local wisdom (strengthen the use of local-based food resources, woman role, community/religion leaders role, mutual cooperation, friendly & harmony, food self-sufficient village, green agriculture, multicultural agriculture, and community based planning), b) the role of Agricultural Technology Institute, or any other department (pilot projecting development, capital access, assistance, and strengthening the system of production-distribution-marketing-consumption).

C. The Green Agro-Industry

Agro-industry is an industry whose raw material comes from agricultural product. The study of agro-industry in this context is focused on the food processing management. Agro-industry is one of the sub-systems in the agro-business system that has proven in giving contribution towards the agricultural development in Indonesia, which are: (1) increase the income of agro-business actor, (2) absorb labor force, (3) increase the foreign exchange income, and (4) stimulate other industries growth (Soekartawi, 2000; Soekartawi, 2005).

According to Andersen and Lorch (2001) in Soekartawi (2005), agro-industry has a strong correlation with perennially problem of poverty, food stability and security. Together with experts from International Food Policy Research Institute (IFPRI), they initiate the program “2020 Vision for Food, Agriculture and the Environment”. The Indonesian Government also launches a program named “Gerakan Industrialisasi Pertanian di Pedesaan 2020” (GERINDA 2020), an action program that is expected to be able to overcome the economic problems that can employ community economic empowering, both in urban area and rural area, either in large-sized, medium-sized or small-sized enterprise. This happens because agro-industry (1) can highly absorb labor force, considering that the characteristic of rural agro-industry which is labor-intensive, (2) use local resources so that it can increase the additional value, benefit, and income, (3) can produce high quality product, so that it can improve the national foreign exchange, (4) increase the circulation of money in the society that will effect on

increasing the community purchasing power, (5) cannot be developed exclusively, will raise and develop other supporting activities.

The Concept of Sustainable Agro-Industry Development is an Agro-Industry Development that is constructed and developed by focusing on management aspects and natural resources conservation. All technology used and also related department are directed to fulfill the human importance nowadays and in the future. The technology used is suitable with the supporting power of natural resources, there is no environment degradation, economically benefits, and socially can be accepted by the community (Soekartawi, 1988; FAO, 1989; Sajise, 1996 in Sorkartawi, 2005). Based on this concept, the characteristics of Sustainable Agro-Industry are: (1) the productivity and the benefit can be maintained or improved in a relatively long period,(2) the agricultural resources that can produce Agro-industry raw materials can be well-preserved,(3) the negative effect from the exploitation of natural resources and Agro-industry can be minimized.

Soekartawi (2005) proposed that in order to develop Agro-industry, these things are needed to be implemented: (1) adjustment towards global change, (2) increase the growth through innovation, investment, and trade, (3) remove the factors that obstruct the growth, (4) increase the efficiency in every factor that influences the Agro-industry Development, (5) increase the managerial quality through human resources quality improvement, (6) able to be autonomous by not suspended to any other side.

The Concept of Sustainable Agro-Industry Development needs to be supported by an efficient agro-industry that puts forward the concept of zero waste. There are several advantage from agro-industry that applies the concept of zero waste which are:

1. Environment preservation

Meaning that the zero waste agro-industry will pay more attention to its production process and its waste management so that it does not harm the environment. This will bring on the positive image for the agro-industry. In the case of banana agro-industry for example, all parts of the banana plant, the cups, the stems, the leaves, the flowers and the fruits can be processed into various products. Banana cups can be processed into crackers. Rods can be processed into banana crackers, chips and shredded. While the flowers can be processed into banana chips, banana shredded and “rendang” (a spicy dish). Banana leaves can be used as food wrapping. The untreated residue will be processed for organic fertilizer. Although produce processed banana is developed towards zero waste technique, it means all parts of the plant are used to be processed into useful products. The SMEs that produces those processed bananas is supporting green agro-industry.

2. People Perception

By applying zero waste, it means that the agro-industry is moving towards green agro-industry where the chemical substance that is safe for the human health and able to reduce the pollutant is used. This will influence the people perception towards the

products, which is safe and good for the human health and environment. This people perception will give a positive effect on the product brand strengthening

3. Competitive Advantage

The application of zero waste that supports the green agro-industry can be a good competitive advantage for the agro-industry to dominate the market competition.

In Indonesia, there are so many micro and small-sized enterprises but they are still not well-integrated, meaning that the one who uses banana inflorescence as raw material, the one who uses banana fruit as raw material, and so on are still individually processed. The challenge that will be faced by Indonesian agro-industry in moving towards green agro-industry is to integrate the micro and small-sized enterprises all together to be able to apply zero waste agro-industry. In the banana production central area for example, the farmers are grouped into the group who cultivates banana plant, the group who processes banana inflorescence, the group who processes banana fruit, the group who processes banana stem into food, the group who process banana stem into craft, and the group who produces organic fertilizer. If these production groups can be well-integrated, the zero waste that supports green agro-industry will be achieved.

CONCLUSIONS

Micro, small and medium-sized enterprises can process all parts of banana plant into various products by applying zero waste concept and finally to support the green agro-industry.

The challenge that will be faced by Indonesian agro-industry in moving towards green agro-industry is to integrate the micro and small-sized enterprises all together to be able to apply zero waste agro-industry.

REFERENCES

- Budiyanto, Moch. Arief. 2012. *Model Pengembangan Ketahanan Pangan Berbasis Pisang melalui Revitalisasi Nilai Kearifan Local*.
<http://citation.itb.ac.id/viewdoc/summary>
- Gunawan, Tata. 2013. *Manfaat Buah Pisang Untuk Kesehatan Tubuh*.
<http://tanamanobat-herbal.blogspot.com/2013/01>. Diakses pada 03 April 2013
- Soekartawi. 2001. *Pengantar Agroindustri*. Jakarta: Raja Grafindo Persada.
- _____. 2005. *Agroindustri dalam Perspektif Sosial Ekonomi*. Jakarta: Raja GrafindoPersada.
- Suyanti dan Ahmad Supriyadi. 2010. *Pisang: Budi Daya, Pengolahan, dan Prospek Pasar Edisi Revisi*. Jakarta: Penebar Swadaya.
- Tambunan, Tulus TH. 2002. *Usaha Kecil dan Menengah di Indonesia, Beberapa Isu Penting* Jakarta: Salemba Empat.
- John.2013. *Immediate Benefits Of Being A Zerowaste Company*. John's Refuse & Recycling, LLC. www.johnsrefuse.com. Diunduh tanggal 12 September 2013.

IMPACT OF PLANT CONSERVATION ON ADDITIONAL INCOME GENERATION IN RURAL GARDENS: A CASE STUDY OF TALAWI MUDIK VILLAGE OF WEST SUMATERA

Sumilah, Nirmala F. Devy And Hayani

Institute for Agricultural Technology of West Sumatra

Jl. Raya Padang-Solok, KM. 40 Sukarami, West Sumatra

Email: Sumilah_utomo@yahoo.com

ABSTRACT

Since two years ago, the government, in this case the Ministry of Agriculture, made a program called 'Region Sustainable Food House' (KRPL / The Region of Sustainable Food House). This program maximizes the used of home garden land to be planted with food crops, such as vegetables, fruits, and medicinal plants. The home garden is traditionally a very important piece of land for rural Households of Indonesia, especially at rural areas, covering an area of about 50 to 200 m². It is a place for people to live in but it also produces a variety of foods and other things for home use, income and conservation plant, if it is managed properly. Indonesian government in 2012 received an award from the FAO on the success of the program KRPL, roommates is to reduce hunger and malnutrition. This study was conducted at Talawi Homecoming Village, Talawi sub district of Sawahlunto city, West Sumatra, from December 2011-December 2012. The objective was to evaluate the type and number of plants are conserved in each sample household, Determine the economic value of home garden crops and the effect of KRPL program implementation to the public response. The results showed that household majority still choose to plant vegetables around their garden, with a number of types of vegetables grown were 25, with an average number of plants were 7-8 every household. In another hand, the food crops (maize, cassava, sweet potato) species were limited, but the average ownership per house hold was higher, ie 10-11 plants. Obtained from the data is up to December 2012, it found that the average estimate of the economic value of existing food crops in the home garden household were for both cash and consume as much as 69.86% and 30.14%, respectively. However, most of the vegetables one was for daily need (87.94%) and the rest were sold (12.06%). This KRPL activity had an average savings percentage donated to the participating Households by 14% of their expenditure. The commodities that can donate income or savings were red chili and onion. This program Began in December 2011 with only 10 initial of participants and at the end of year 2012, they Increased up to 590%.

Keywords: home garden, plant conservation

INTRODUCTION

In general homestead in Indonesia is a very important part of the overall land ownership. According to FAO (2013) and Mazumdar and Mazumdar (2012) can be

defined as the homestead farm system that combines the functions of social, spiritual and economic. At a social function, the yard is an area that can be used for meetings, children's playground and park. While the economy means that the function is an agro-ecosystem yard area that can be used to produce a variety of food sources, energy materials, and fiber (Calvet-Mir *et al.*, 2012) so that it can be used to supplement income by planting crops, medicinal and tree- trees as well as a way of raising animals and fish. According to Davies *et al.* (2009) the yard is also a resource for biodiversity and important sites for conservation in situ within ecozones (Trinh *et al.*, 2003).

According to the minister (in Riri, 2013) yards that can be used to grow crops \pm 10 million hectares. Seeing the potential for such extensive yard area, since two years ago, the government, in this case the Ministry of Agriculture, a program Region Sustainable Food House (KRPL). This program maximizes the slightest homestead land to be planted with food crops, such as vegetables, fruits, and medicinal plants; program was implemented to support the food security program. The success of this program is appreciated by the FAO (2013) by giving the award "Outstanding Progress Award in Fighting Hunger and undernourishment" to Indonesia because Indonesia could also meet the first target of the global development agenda (MDGs / Millennium Development Goals (MDGs) in which the first goal of the MDGs is that in 2015 every state will be able to reduce poverty and hunger by half of the initial conditions in 1990. program is also expected to meet the Recommended Daily Intake of Energy (AKE) availability, which was originally 2,200 kcal / person / day to 2,400 kcal / person / day and consumption of 2,000 kcal / person / day to 2,150 kcal / person / day (Anonimus, 2012).

In West Sumatera yard wide reach 84 247 ha of land spread over 12 districts and 7 cities. Whereas in Sawahlunto own, dedicated residential land / yard area Km² 12:05 (Bappeda and Sumatra BPS, 2011). Considerable potential this is one potential source provider of food that has nutritional value and high economic value, such as vegetable and fruit crops. Guarantee that yard with well, fruit + vegetable consumption is expected to increase which also increases the expectation of food patterns (PPH) community (Ariani, 2010), as did the people Sumbar, because according to the DKP (2009), in Indonesian provinces with a prevalence highly food insecure <10% in the year 2008 in addition to Bali one of which is the province of West Sumatra (7.4%).

The purpose of this activity is to assess the distribution of crops in home gardens as well as savings in the household expenditure in Sawahlunto, West Sumatra after the application of Model Region Sustainable Food House (MKRPL).

METHODS

Assessment activities carried on in Hamlet KWT Manih Lansek Sago, Homecoming Talawi Village District Talawi, Sawahlunto starting November 2011 s/d in December 2012. Assessment is done through several stages, namely implementation in selected locations MKRPL implementation, evaluation and development of evaluation participants and the distribution of plants of economic value of the crop.

Approach method for characterizing regional sustainable food model development is done through desk study and field survey by the method of PRA (Participatory Rural Appraisal) and structured survey on a sample implementation of this activity is done

with the involvement of the target group members KWT Lansek Manih and technology assistance by researchers, extension workers and offices/agencies. Developmental evaluation is done by calculating the RPL participants participation MKRPL members from the beginning and end of the activity, evaluation of the economic value of the plant is done by calculating the economic value of the crop every member, both plants are consumed or sold.

Parameter/observed data is a commodity that has been developed and introduced in their yards, the amount of household food expenditure per month before and after applying MKRPL. Data were analyzed descriptively, tabulation (% , ratio, on average).

RESULTS AND DISCUSSION

A. Characterization of M-KRPL Development Area

Characterization of M-KRPL development areas through desk study, field surveys by the method of PRA (Participatory Rural Appraisal. Obtained from the results of this activity that Talawi Villages Village Homecoming is one of seven village in District Talawi Sawahlunto. Broad Village reaches 876 ha, comprising 4 Pillars of Citizens (RW). residential land area reaches 15% of the area of the village. population numbered 75 families or 2587 people.

By strata, implementing community wide yard MKRPL in Talawi Homecoming activities Sawahlunto (33 members) can be grouped into 4, namely a) very narrow grounds (no yard) b) narrow grounds (area <120 m²), c) moderate yard (wide 120-400 m²) and d) extensive grounds (area> 400 m²) (Table 1.).

Table 1. Extensive grounds KWT participants Lansek Manih MKRPL development activities in Talawi Sawahlunto

No.	Level	% HF
1.	Very narrow grounds (no yard)	20 %
2.	Yard narrow (<120 m ²)	20 %
3.	Yard medium (120-400 m ²)	20 %
4.	Yard wide (> 400 m ²)	40 %

Design commonly applied is planting vegetables on the shelves, polybags and beds for each plant morphology that have short and tall. To implement the design, MKRPL members were shelves and polybag for planting.

B. Evaluation of Development of Participants

Sago MKRPL activities in Hamlet, Village Talawi Homecoming, Sub-Sawahlunto Talawi began in December 2011 with only 10 initial participants who are members Dasa RT Lansek Manih Pensions. At the beginning of the year (February 2012), Dasa Wisma developing activities that formed the Women Farmers Group (KWT) called KWT Lansek Manih consisting of 18 people, so it automatically increases the activities of participants to 18 people. Success in the field of activity of KWT RPL candidates replicated by other groups of women farmers consisting of 16 people, and supported by the Head of Hamlet in October 2012 Sago Region Sustainable Food Houses initiated by

the addition of as many as 35 public participants (Figure 1a.), So in general M-KRPL percentage of participants until the end of December 2012 rose to 590% (Figure 1b.)

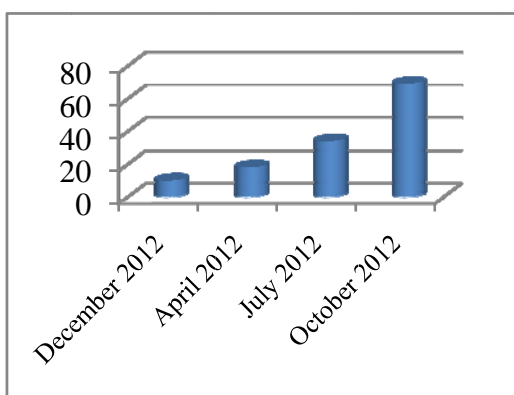

figure 1a. The number of participants MKRPL

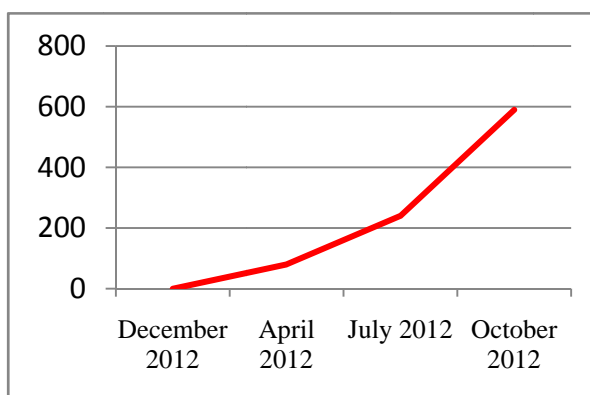

figure 1b. Developments% of participants MKRPL

C. The Type And Number of Plants That Are of Interest Members of RPL

Until the end of December 2012 found that the majority of participants still choose to plant vegetables around his yard, with a number of types of vegetables grown totaled 25 with an average number of plants reaching 7-8 plants / RT. As for the food crops (maize, cassava, sweet potato) species were planted very limited (6 types), but the average ownership per family is 10-11 plants / RT (Figure 2).

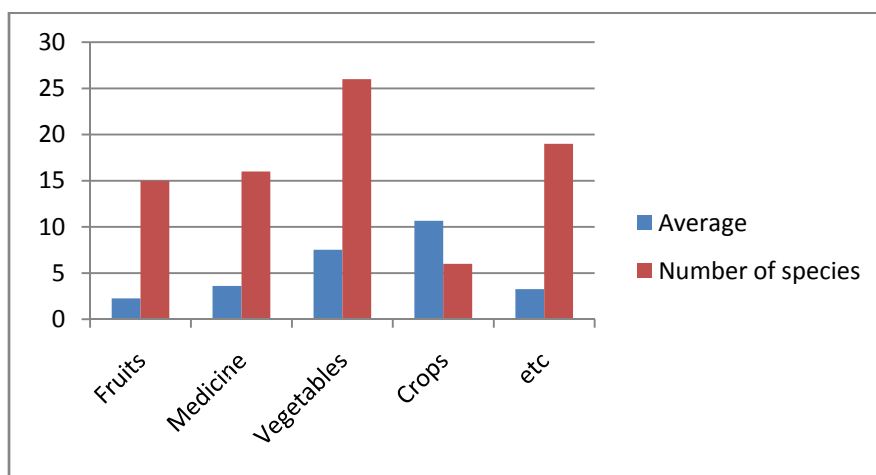

Figure 2. Number of crop species and the average number of plants / RT are cultivated in their yards Sago MKRPL Hamlet, Village District Talawi Homecoming Talawi Sawahlunto.

While the vegetable plants, three main types of participants are predominantly cultivated by red chilli (chillies curly), eggplant and celery (Figure 3). that are characteristic of the Minang cuisine.

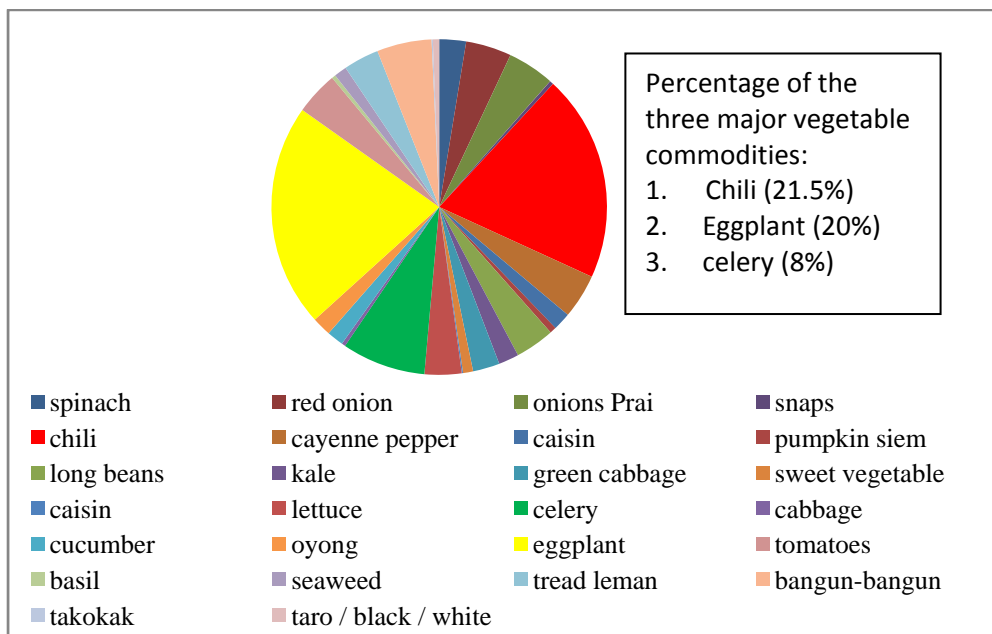

Figure 3. Percent types of vegetables are cultivated by participants MKRPL Talawi Homecoming Village, District Talawi Sawahlunto

In addition because of the need, in general commodity vegetables and fruits commonly cultivated in home gardens because it is relatively easily cultivated in a limited area. Commodities are widely grown in the rack, polybags and secondhand containers that are not used. From the many studies done on the function of the yard, and Isendahl Barthel (2013) to conclude that the use of the yard and the farm environment has contributed to the high long-term food security during the era of energy scarcity

Purchasing power of some segments of society are limited, especially for the allocation of the need for food is a cause of non-fulfillment of a balanced nutrition food. On the other hand, the opportunity to produce a particular food source independently by the household is available. Utilization of agricultural land to the cultivation yard optimally is one alternative for households to obtain food security, improving nutrition, increasing outpouring of productive forces, neighborhoods and health improvements all of which leads to an increase in income and standard of living (welfare) people of the region. With the requirement of vegetables in every household, decreasing purchasing power negatively affecting the decline of animal and vegetable food purchases + fruit would be solved (Ariani, 2010).

RPL participants' responses to the type of crop area of land / strata (Figure 5.) Shows that the exploitation of the stratum 2 types of vegetables is higher than level 1, 3 and 4. Vegetables very well responded by the participants MKRPL commodity fruits while second place.

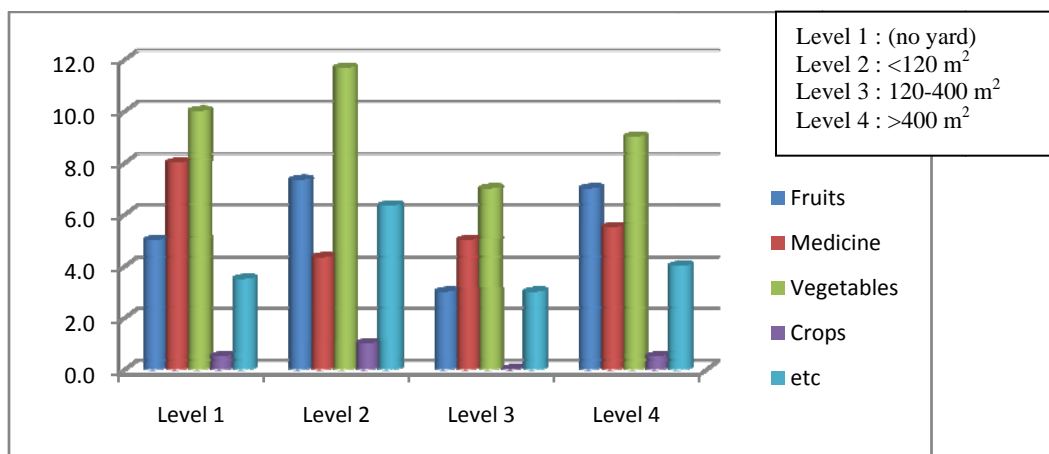

Figure 4. RPL participants' responses to the type of crop area of land / level Talawi Homecoming Village District Talawi Sawahlunto

D. Economic Value Planting

From the data analysis, found that the average estimated percent of the economic value of the existing group of food plants in the yard for the sale and consumption respectively 69.86% and 30.14%. As for the vegetable group, inversely proportional to their utilization of food crops, where as much as 87.94% to meet the needs of the rest of the new rumahtangganya sold (12:06%) (Figure 5a. And 5b.).

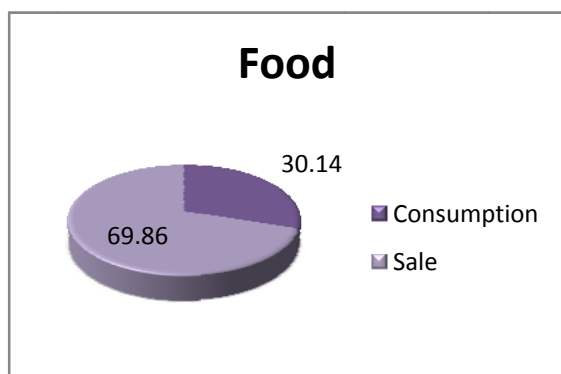

Figure 5a. The percentage utilization of food commodities for economic RT

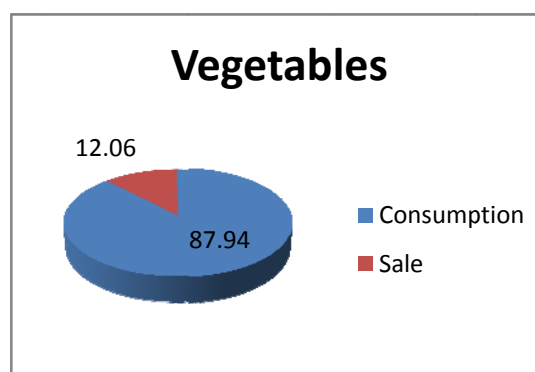

Figure 5b. The percentage utilization of vegetable commodities for economic RT

Of the recapitulation of sales and products consumed by households, found that the presence of MKRPL activity, the average member of KWT Lansek Manih resulted in savings of household expenditure per month (particularly on family food expenditure) amounted to 14% of expenditures previously (Figure 6). Commodities that can donate income or savings include red pepper and red onion.

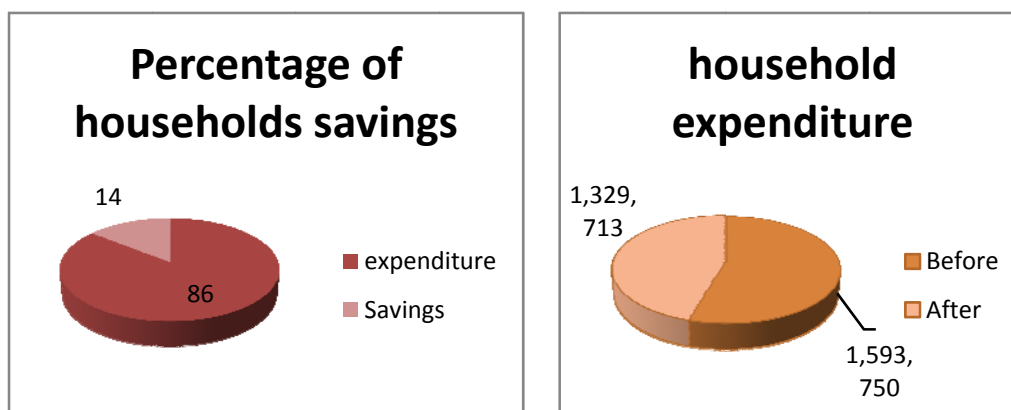

Figure 6a. Saving an average percentage of participating households MKRPL

Figure 6b. Average expenditure of participating households MKRPL

Adequate food availability at the macro level (national, provincial and district / city) is an important factor but it is not sufficient to ensure the availability and consumption of adequate food at the household and individual level. By striving for their own food needs, will reduce the low availability and food consumption at household level that may occur due to problems in the distribution and household economic access to food (DKP, 2009).

CONCLUSION

1. In the village of Homecoming Talawi Sawahlunto M-KRPL percentage of participants until the end of December rose to 590%. Three major vegetable commodities that are in demand by participants MKRPL red chilli (21.5%), eggplant (20%) and celery (8%)
2. RPL activities of MK-2012 in KWT lansek Manih have donated an average savings percentage of participating households by 14%, which can be donated commodities revenue or savings include red pepper and red onion.

ACKNOWLEDGEMENTS

Thanks are conveyed to Farida Artati, Rum Herayitno and Fadli Anwar and all those who have helped.

REFERENCES

- Anonimous, 2012. Widyakarya National Food and Nutrition (WNPG) X in 2012 with the theme: "Strengthening Food Security and Nutrition Improvement Independence and Community-Based Local Wisdom". www.wnpg.org
- Ariani, M. 2010. Analysis of food consumption level of the community to support the achievement of food diversification. *Indon Nutrition* 33 (1) :20-28

- Bappeda and BPS West Sumatra, 2011. West Sumatra in the figure in 2011. Bappeda and the Central Bureau of Statistics of West Sumatra province. Padang.
- Barthel, S. and C. Isendahl. 2013. Urban gardens, agriculture, and water management: Sources of resilience for long-term food security in cities. *Ecological Economics* 86: 224-234
- Calvet-Mir, L., E. Gómez-Baggethun and V. Reyes-García. 2012. Analysis Beyond food production: Ecosystem services provided by home garden s. A case study in Vall Fosca, Catalan Pyrenees, Northeastern Spain. *Ecological Economics* 74: 153-160
- Davies, Z.G. , R. A. Fuller, A. Loram,, K. N. Irvine, V. Sims and K. J. Gaston. , 2009. A national scale inventory of resource provision for biodiversity within domestic gardens. *BIOLOGICAL CONSERVATION* 142: 761-771.
- Food Security Council, 2009. Draft-4. Indonesia hold food and nutrition. 55 pp
- Indriani, R. 2013. Indonesia will not be short of food. Taken from <http://www.beritasatu.com/nusantara/121383>
- Mazumdar, S. and Sanjoy Mazumdar. 2012. Immigrant home gardens: Places of religion, culture, ecology, and family. *Landscape and Urban Planning* 105: 258-265
- Trinh, L.N., J.W. Watson, N.N. Hue, N.N. De, N.V. Minh, P. Chu, B.R. Sthapit and P.B. Eyzaguirre. , 2003. Agrobiodiversity conservation and development in Vietnamese home gardens. *Agriculture, Ecosystems and Environment* 97: 317-344

THE ROLE OF WOMEN IN DEVELOPING ENTREPRENEUR / MERCHANDISE CASE IN MAJU MAKMUR SMALL GROUP ACTIVITY (SGA) KEJAJAR DISTRICT, WONOSOBO REGENCY, CENTRAL OF JAVA

Teguh Kismantoroadji and Indah Widowati
Agribusiness Study Program, Faculty of Agriculture, UPN "Veteran" Yogyakarta
Jalan SWK 104 Condongcatur Sleman Yogyakarta 55283
e mail : kismantoroadji@gmail.com dan widowati2010@gmail.com

ABSTRACT

The purpose of research is to find out to see how the development of entrepreneurs in Maju Makmur Small Group Activity (SGA) lasts . The research methodology used was qualitative research with in-depth interviewing administrators Maju Makmur Small Group Activity (SGA). Results showed that women successfully develop entrepreneurship in Maju Makmur Small Group Activity (SGA) and the resulting product, able to be sold in a variety of areas at competitive prices .

Keywords : Women, entrepreneurship, Small Group Activity (SGA)

INTRODUCTION

Dynamics of entrepreneurial development in a country can not be separated from the participation and role of women. Minniti, *et al.*, (2005 , *in* Teak 2009), found that the participation of women as entrepreneurs have been rising sharply over the last decade and turned increasingly significant both in the developed and developing countries. However, a growing number of women business owners (women- owned business) remains systematically lower than that of men.

Women's participation in the activities of the business establishment were also lower, in which men doubled frequency compared with women. The proportion of the worse in developing countries, due to the participation of men nearly 75% (Minniti and Arenius , 2003 *in* Teak , 2009). The inequality above is supported by Wilson (2007 *in* Jati , 2009), which states that women's ownership of the business in Asia, Africa, Eastern Europe, and Latin America only 25%, with the rest owned by men .

The presence of women entrepreneurs in the Micro, Small, and Medium Enterprises (SMEs) are the economic realities of the majority of Indonesian people. The role of women micro entrepreneurs in the Indonesian economy slowly turns increasingly to be "keeper" of the people 's economy . SME ownership data show in detail that as many as 44.29% of micro enterprises run by women, as well as in the small business sector as much as 10.28% (CBS, 2005, *in* Jati , 2009). Meanwhile, State Minister for Women Empowerment report (October, 2007, *in* Jati , 2009) states that 60% of the 41 million

micro and small entrepreneurs in Indonesia are women .

That's why researchers are interested to elevate the role of women in developing entrepreneurship in Maju Makmur Small Group Activity (SGA) Kejajar District, Wonosobo Regency, Central of Java. The purpose of research is to see how the development of entrepreneurs in Maju Makmur Small Group Activity (SGA) going forward ?

LITERATURE REVIEW

The involvement of women in entrepreneurship, a study of several researchers, including Ardhanari (2007), which examined the profile and barriers women entrepreneurs in Indonesia to develop. Findings are very interesting because it mentioned barriers women entrepreneurs are caused by personal characteristics of the workload due to the dual role of a woman and structural characteristics, the barriers to access to capital (and collateral requirements) and access to markets where women have lower access to marketing information. It was concluded that barriers to the development of women entrepreneurs is the result of gender stereotypes (gender stereotypes) between women and men in a patriarchal environment .

Wilson *et al.* (2007) research emphasis on personal factors (personality characteristic), namely self -efficacy. Research results provide data that women have self-efficacy and self-confidence are lower than men in mathematics, finance, decision making, and problem solving. Though this is a major factor related to the skills and expertise of men and even become determinant in driving the success as an entrepreneur. Aligned with Kickkul *et al.* (2004) which states that self-efficacy of men is higher than women. In fact, self -efficacy is an important factor for entrepreneurs to develop and master the skills needed and will ultimately have an impact on career success .

Another researcher, Engko (2006) conclude that there is a significant positive relationship between the level of self-efficacy and individual performance. If a person who has high self-efficacy will have a better performance boost in all areas of employment, including career choices (intentions) as an entrepreneur. Self-efficacy will increase optimism for someone to always turn out better and keep trying to reach a certain goal .

Zulminarni (2004) found that an important factor influencing the development of entrepreneurship is the human factor which include : personality business, education, environment, experience, and ability to earn money, social values, culture, and the opportunities are determined by the environmental, economic stimuli such as market opportunities, profits, demand is elastic, the business climate and government regulations. Biological Assessment (2007) found that entrepreneurial personality is a major factor, followed thereafter ability factors, technological factors, and other factors. Personality trait most widely discussed by experts in terms of entrepreneurship, is a creative and innovative nature.

Based on the above, the study/review the establishment or development of entrepreneurship (entrepreneurship) with a variety of theoretical approaches need to be developed. From these studies are expected to be generated by a new idea or innovation is "strategy formation/development of entrepreneurial spirit (entrepreneurship)" in order to develop the quality of human resources in Indonesia, particularly the role of

women.

METHODOLOGY

The focus of this study is the disclosure process and the interpretation of meaning. In this study, held assumption that women and entrepreneurs not only revealed a relationship, but also on the pattern of action or interaction with the surrounding conditions of the development of entrepreneurial businesses.

Based on these assumptions, this study focused on a qualitative approach. The term refers to the process of qualitative and meanings that are not rigorously examined or measured in terms of quantity, intensity or frequency, emphasis is given on the nature of the social construction of reality and find answers how social experiences shaped and given meaning (Denzin and Lincoln, 1994). According to Denzin and Lincoln (1994), Creswell (1994) and Maxwell (1996), for research that focuses on the disclosure process and interpretation of the meaning of a qualitative approach is more relevant. Qualitative approach here means a qualitative way as the methods and techniques of assessment .

The approach was to conduct in-depth interview to Forward Maju Makmur Small Group Activity (SGA) officials in order to obtain an overview of entrepreneurship development and the role of women

RESULTS AND DISCUSSION

A. Starting from the Wasted Fruit, Eggplant Netherland

Dutch eggplant previously eaten a lot of fresh fruit or vegetables for a vegetable substitute, it can be enjoyed as a syrup for drinks. Interestingly, Dutch or eggplant syrup known as *Kemar* this was also sweet and fresh as syrup of orange, mango, pineapple, guava and other fruits .

Uswatun Khasanah (33), women from Sikunang RT. 07 RW.1 Kejajar Wonosobo, as Chairman of the Maju Makmur Small Group Activity (SGA) *Kemar* trying to process the fruit into syrup. It began when the slender-bodied woman finds the fact that in the surrounding area, Sikunang village who entered in the Dieng mountains, found many fruitful *Kemar* plants. For those who do not recognize, at a glance *Kemar* fruit resembles a thick-skinned tomatoes. Shape vary, there are oval or round like chili. *Kemar* ripe fruit is red. The flesh is also red. If the cut pieces will drain the water red. Well, from the contents of the Dutch eggplant fruit syrup that *Kemar* made .

"*Kemar* Dieng fruit contains vitamin A which is very good for eye health. There was also a content of vitamin C that can treat ulcers and increase endurance. Essential minerals such as potassium, phosphorus and magnesium was even able to keep and maintain a healthy body. High fiber in the fruit *Kemar* be useful to prevent cancer and sembililit," said the other administrators .

Told, the idea of processing fruits into syrup *Kemar* began when the Dutch got eggplant fruit underestimated and not much use. Trees that grow in many fields harvested. Even when the trees bear fruit, so it is left scattered. That's because people assume that it is not good *Kemar* fruit consumed.

Extreme, Netherlands eggplant tree is considered as a parasite for the potato crop.

Hence not a few people who choose to prune the tree from the preserve. "People are afraid to eat for fear of poison and the unpleasant smell of his skin. When it is, there is absolutely no one who would eat raw eggplant. Moreover, if split, the fruit can be red like the blood shed" Uswatun said.

B. Variety processed in the Context of Entrepreneurial Business

The first time *Kemar* process Dieng, Uswatun admitted, the idea emerged after Maju Makmur Small Group Activity (SGA) given cookery training opportunities to make drinks and meals organized by the Office BIKK Wonosobo in Central Java and Infocom 2005. In training, try to drink processing *Kemar* Dieng. As a result, it turned out incredible. Because the fruit is initially thought to be nearly extinct and should not be eaten, can be processed into fresh and sweet drinks.

Uswatun beliefs as Chairman of Small Group Activity (SGA) is getting stronger, after investigation related parties, *Kemar* fruit consumption is actually safe and nutritious and can be used as an ingredient drinks and other foods that can be utilized. Since then, Uswatun with some women in the village who are members of Maju Makmur Small Group Activity (SGA), more determined to take advantage of *Kemar* fruit into syrup, jams, and sauces. Farmers who originally cleared the Dutch changed cultivate eggplant.

KUB officials said to the others, this syrup is made from *Kemar* juice, sugar and water. This drink without preservatives with natural color purplish red. "Although no preservatives *Kemar* syrup can last longer," she said.

How to make it, very easy. *Kemar* fruit that is ripe sorted, washed and peeled. Once peeled sliced to take the juice. The juice is filtered and mixed with sugar, then boiled. After the water boiled syrup *Kemar* filtered so clean and straight put in a bottle of syrup. " *Kemar* made cider syrup being made flesh and processed for liquid and jam made carica seeds in syrup".

On how to manufacture jam, Uswatun said the way was also very easy. First, the meat is mixed with a blend of fruit sugar. Cook until thick. "If making *Kemar* meat sauce mixed with salt, herbs and pepper and blend".

C. Profitable

So far every time production, Maju Makmur Small Group Activity (SGA) able to produce 300-400 bottles of syrups, sauces and jams. Number of production as much as it is done by six employees of the production and packaging. "Within a month of production could beromzet around Rp 20 million".

About the price it set a large bottle of syrup Rp 18.000, carica in syrup (small) Rp. 12.500, jam (small) Rp 15.000 and the sauce (big bottle) Rp 15.000. Including instant sales *Purwoceng* in sachets at a price of Rp 5,000/sachet, able to provide job opportunities. During this time, the market potential, called Uswatun there in the town of Wonosobo and Dieng. However, it has also expanded its market *Kemar* syrup until several cities in Central Java, Semarang, Bandung, Yogyakarta, and Jakarta". *Kemar* drink or jam, it would make a great gift" said some board Small Group Activity (SGA).

Entrepreneurial development in rural context as micro or small businesses, including

Maju Makmur Small Group Activity (SGA), the economy has a strategic position, given the number of Wonosobo Regency population is relatively large with an average education levels are still low and most live in the activity of micro or small well in the traditional sector. Position or the role of women in developing strategic placing of micro entrepreneurs or small, needs to be a concern at all stages of development in the district.

However, the development of entrepreneurial businesses in Maju Makmur Small Group Activity (SGA) has done is not satisfactory because of the perceived presence always behind because of limited capital, resources, and coaching. Related to this, the role of women was able to lift the economy of the village/sub-district/district-based income generation of local raw materials. Therefore, the role of women in developing entrepreneurship, at this moment could be felt more and more strategic for economic uplift of the people. People's economy is synonymous with micro and small businesses that in its development childbearing women entrepreneurs.

CONCLUSION

- 1 . Successful women entrepreneurs in developing Maju Makmur Small Group Activity (SGA).
- 2 . The resulting product, able to be sold in a variety of areas at competitive prices.

BIBLIOGRAPHY

- Ardhanari, Margaretha, *et. al.* (2007). Analisis Personal Dan Struktural Purnik (Perempuan Pengusaha Mikro) Di Surabaya Dalam Upaya Pengembangan Keberhasilan Usaha Bidang Ritel. Makalah disampaikan pada Lokakarya Regional : “Pengembangan Kewirausahaan Perempuan dalam Usaha Mikro & kecil”, Bali, 29-30 November 2007
- Creswell, J.W. 1994. *Research Design: Qualitative and Quantitative Approaches*. London: SagePublications.
- Denzin, N.K. dan Y.S. Lincoln (Eds.). 1994. *Handbook of Qualitative Research*. Thousand Oaks: Sage Publications.
- Jati, Waluya. 2009. “Analisis Motivasi Wirausaha Perempuan (Wirausahawati) di Kota Malang”, *Jurnal Humanity*, Volume IV, Nomor 2, Maret 2009: 141 - 153
- Maxwell, J.A.. 1996. *Qualitative Research Design: An Integrative Approach*. London: Sage
- Zulminarni, Nani, 2004. “Lembaga Keuangan Mikro Dalam Rangka Pemberdayaan Perempuan Miskin”, Disampaikan dalam acara workshop *Berbagi Pengetahuan dan Sumberdaya Keuangan Mikro di Indonesia* yang diselenggarakan oleh GEMA PKM Indonesia dan BWTP di Jakarta 27 Agustus 2004.
- Hayati, Amelia. 2007. “Studi terhadap Pemberdayaan Perempuan dalam Pengembangan UMKM di Kabupaten Garut”, disampaikan pada Seminar *Membangun Garut Melalui Sumberdaya Lokal Berpotensi Global* Kerjasama Pemerintah Daerah Kabupaten Garut dan Lembaga Penelitian UNPAD. Tanggal 11 Desember 2007.

ANALYSIS EFFECT OF ENVIRONMENTAL FOOD PRODUCTION TOWARD CONSUMER'S INTERMEDIATE BEHAVIOUR PRODUCT SLICE NOODLE

Novita Erma K.

Jurusan Teknologi Industri Pertanian FTP UGM

Jl. Flora I Bulaksumur, 55281

(Timur Balairung Gedung Pusat UGM)

ABSTRACT

Local food industry must developed in order to fulfill the needs of food. One of the local food industries which is produce slice noodle is “Bangkok”. This industry had Certificate of Home Industry Food Production, and applied the good and right method of food production. Based on the observation, consumer did not understand the function of the good and right method of food production. Consumer's reason to buy slice noodle can't be predicted. Sampling method in this research was purposive sampling. The respondents were intermediate consumer, which were buying slice noodle to be processed and sold to end consumer. Multiple linear regression analysis were conducted with X1 (Sanitation-Hygiene), X2 (Process Control), X3 (Control Management), and Y (Consumer Behaviour). Multiple Linear Regression Equation is $Y = -1,372 + 0,422 X1 + 0,266 X2 - 0,021 X3$, with the highest effective contribution and relative contribution is 68,25 % and 81,65 % respectively for X1 (Hygiene and Sanitation), so the most influential variable toward consumer behaviour is X1 (Sanitation-Hygiene).

Keywords : local food, method of food production, multiple regression, consumer behaviour

INTRODUCTION

One of the problems developing countries is increasing population and not balance the provision of food crops. There are several attempts to resolve the issue including by improving cultivation and utilization of agricultural products as possible, especially vegetable food sources. Thus, people can still consume a variety of foods that can increase the diversity of food patterns and food availability is guaranteed.

The content of nutrients staple food in general is carbohydrates. In Indonesia, many plants that produce food sources of carbohydrates such as root crops. However, root crops currently not widely consumed. One of the tubers that are found in Indonesia is cassava or cassava.

An alternative to get a higher economic value is a variety of processing, such as making alternative food preparations of starch in the form of noodles. Noodle is popular product in Indonesia and liked almost all people, from children to adults. In general, the main raw material is wheat noodles, but can also be derived from starch or a mixture of both.

According to the Chairman of the Indonesian Flour Producers Association (Aptindo) Franciscus Welirang (2008), the grain consumption continues to increase, and showed a significant increase each year. In fact, the trend of demand for wheat flour continued to increase every year, then within the next ten years the national wheat seed needs to

reach 10 million tons per year. With the need for it, then Indonesia certainly become the largest wheat importer in the world. Current title as the country's largest wheat importer is still held by the Egyptians, who last year imported about eight million tonnes. In 2008 wheat flour consumption nationwide, according to records Aptindo, reaching 3.8 million tons. Total requirement of wheat flour is equivalent to about 4.5-5 million tonnes of wheat a whole grain (100%) still had to be imported from abroad.

Cassava Noodle is a product of a mixture of cassava flour and cassava starch and can be made in the form of wet or dry. One of dried cassava noodle products that have been known to the public is Bendo noodles produced by one businessman in Hamlet Bendo, Bantul regency, Yogyakarta. This noodle also often called "letheke" noodle because of his physical appearance is brown due to processing that do not use preservatives and bleach. The other noodle product is sliced noodles, can be found in Pundong, Bantul, Yogyakarta. a type of food made from cassava rather large size, it feels spongy, and easily stretched.

One attempt noodles is sliced noodles that owned by Mr. Mulyono, who already have SPP-IRT (Certificate in Food Production-Industrial Household). The business is still relatively small and medium enterprises scale processing process is still using simple tools.

Consumers is buy a slice noodle in the industry, typically used for processing longer be "midhes", which was later sold in shops / houses respectively. Such consumers are consumers intermediates. Customers mi iris also come from outside the area Pundong, the average customer is aware and choose to buy noodles in the iris Mr Mulyono industry because the industry is the first industry that has SPP-IRT, but in fact most do not understand the functions and benefits of CPPB (*Method Good Food Production*) which is a requirement in getting the SPP-IRT.

METHODS

Object study is consumer intermediates slice noodle products manufactured by SMEs in Klisat, Pundong, Bantul, Yogyakarta. In collecting information, which is needed as an informant is it self slice noodles customer when purchasing the product, as the buyer shall be deemed to represent the profile of consumers who have interest in the product (both for personal consumption and processed for resale), and the internal industry (owners and employees) are considered the most understand the industrial condition.

Population and Research Sample

This research was conducted with survey research. Limited in terms of understanding the survey sample survey in which information is collected from most of the population to represent the entire population using a questionnaire. In the study, the use of questionnaires is essential to collect data from respondents. Population and samples were consumers intermediates sliced noodles, some 14 people (based on frequency of purchase).

RESULTS AND DISCUSSION

Slice Noodle is the kind of local food from area Pundong, Bantul, Yogyakarta. This is the basic ingredient cassava noodle starch. Slice noodle has a chewy texture. Moreover

flavored noodles and sliced yellow yet. Mr. Mulyono is established in 1998. Initially production capacity is only 5-10 kg and is only sold to market themselves by Mrs. Mulyono. Demand is increasing production to 100 kg per day. In 2008, through the help of Mr. Mulyono government certified P-IRT with P-IRT No.: 20 634 020 1653. Until now the production capacity of Mr Mulyono has reached 120 kg per day.

A. Descriptive Analysis of Respondents

Description of respondents obtained from the results of the questionnaire for the study was calculated from the total amount are 14 respondents. The selection of the respondent amounted to 14 are based on the frequency of purchases mi iris. Description data consists of only respondent gender and age.

1. Sex

Characteristics of respondents by sex divided into two categories, namely men and women. Of 14 respondents (consumers intermediates mi iris) is known by 50% of respondents were male, while the remaining 50% are women

2. Age

Characteristics of respondents by age divided into 5 groups, which range in age <20 years, 20-30 years, 30-40 years, 40-50 years, and > 50 years. Of 14 respondents, 14% were known spanned age <20 years, 7% were spanned ages 20-30 years, 22% were in the age range 30-40 years, 36% were in the age range 40-50 years, and the remaining be extended to as much as 21% aged > 50 years

Table 1. The Component for Variable X

Variable X	Type Variable Benchmark
X1 = sanitation-hygiene	<ul style="list-style-type: none"> a. Facilities and hygiene and sanitation activities (equipment washing / cleaning, facility employee hygiene, sanitation and hygiene activities) b. Pest control (prevention of entry of pests, pest control) c. Health and hygiene of employees (employee health and hygiene of employees)
X2 = Facility	<ul style="list-style-type: none"> a. Production space (floor, ceiling, completeness production space) b. Production equipment c. Water supply
X3 = Process Control	<ul style="list-style-type: none"> a. Determination of raw material specifications b. Determination of the mode of production of raw c. Storage (storage of materials and products)
X4 = Control Management	<ul style="list-style-type: none"> a. Record keeping and documentation b. Training for employee

The Component for Variable Y is Consumer Behavior.

B. Research Analysis Instruments

1. Validity Test

Table 2.

Validity of Test Results Variable Sanitation-Hygiene, Building-Facility IRT, Process Control, Management Control Management, and Consumer Behavior

No	Question Item	r result	r table	Keterangan
Variable Sanitation-Hygiene (X1)				
1	Item 1	0,660	0,5324	Valid
2	Item 2	0,617	0,5324	Valid
3	Item 3	0,754	0,5324	Valid
4	Item 4	0,607	0,5324	Valid
7	Item 7	0,685	0,5324	Valid
8	Item 8	0,710	0,5324	Valid
Variable Facility (X2)				
9	Item 9	0,629	0,5324	Valid
10	Item 10	0,694	0,5324	Valid
11	Item 11	0,645	0,5324	Valid
12	Item 12	0,591	0,5324	Valid
13	Item 13	0,585	0,5324	Valid
Variable Process Control (X3)				
16	Item 16	0,688	0,5324	Valid
17	Item 17	0,794	0,5324	Valid
18	Item 18	0,797	0,5324	Valid
Variable Control Management (X4)				
19	Item 19	0,579	0,5324	Valid
20	Item 20	0,589	0,5324	Valid
Variable Consumer Behavior (Y)				
21	Item 21	0,635	0,5324	Valid
22	Item 22	0,700	0,5324	Valid
23	Item 23	0,617	0,5324	Valid

2. Reliability Test

Reliability test indicates the stability and consistency of measuring instruments when measuring instrument will be used to measure the same aspect in the study repeatedly.

Table 4.

Reliability Testing Results Sanitation-Hygiene, Facility, Process Control, Management Control Management, and Consumer Behavior

Reliability Statistics

Cronbach's Alpha	Cronbach's Alpha Based on Standardized Items	N of Items
.942	.945	19

Based on the results of the reliability test with SPSS 16 software is known that the value of Cronbach's Alpha (A) is 0.942 where the value of $A > 0.8$, which means the results of reliability test is very reliable.

Table 5. Population Data Normality Test Results

One-Sample Kolmogorov-Smirnov Test

		Standardized Residual
N		14
Normal Parameters ^a	Mean	.0000000
	Std. Deviation	.87705802
Most Extreme Differences	Absolute	.127
	Positive	.127
	Negative	-.080
Kolmogorov-Smirnov Z		.476
Asymp. Sig. (2-tailed)		.977

a. Test distribution is Normal.

The criteria used are:

Ho: The data come from populations with normal distribution

Ha: The data come from a population that is not normally distributed

Asymp value Sig. (2-tailed) is 0.977, which means > 0.05 , then Ho is accepted, meaning that the data came from a population that is normally distributed.

3. Linear Regression Test Requirements

a. Linearity test Regression Line

Linearity test of the regression line relating to verification whether the model of linear regression line really set in accordance with the situation or not. Measure that can be used whether or not the line of linear regression using the linear coefficient of Deviation From Linearity significance.

The criteria used are H0 stating shaped linear regression model accepted if the coefficient of the significance of Deviation From Linearity > 0.05 .

Table 6.

Linearity Regression Line Test Results Item	Significance	Alpha	Conclusion
Y*X1	0,264	0,05	Linear
Y*X2	0,027	0,05	Not Linear
Y*X3	0,777	0,05	Linear
Y*X4	0,200	0,05	Linear

Based on the results of the linearity test above the regression line, the regression models stating Ho received the full linear regression shaped by variables X1 (sanitary-hygiene), X3 (process control), and X4 (management control), whereas the variable X2 (building-facility IRT) declared not linear. To overcome these lines ketidaklinearan use the data transformation to ln or log. But after the transformation, either ln or logs, variable X2 (building-facility IRT) remains linear.

Then, based on interviews with the respondents, it was 78.57% of respondents thought that the sanitary-hygiene-building facility with IRT. In addition, assessments for sanitary-hygiene facilities and building-IRT in the industry quite well, so that researchers eliminate variables IRT-building facility. New variables are analyzed further is variable X1 (sanitary-hygiene), X2 (process control), and X3 (management control). Furthermore linearity regression line was tested using standardized regression plot of regression standardized predicted residual value as follows:

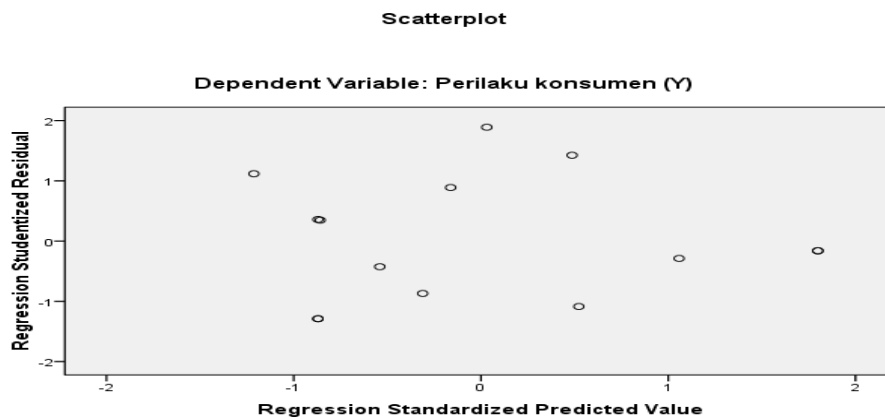

Fig 1. Linearity test Regression Line

Based on the images can be seen that the plot of regression standardized residual and standardized regression predicted values form a random pattern, it can be said that the regression model is linear, so it can use multiple linear regression equation.

b. Multicollinearity Test

Table 7. Multicollinearity Test Results

No	Variabel	<i>Tolerance</i>	VIF
1.	Sanitasi-higiene (X1)	0,433	2,308
2.	Process Control (X2)	0,192	5,220
3.	Control Management (X3)	0,314	3,186

Based on the above table it can be seen that the values of the three independent variables $Tolerance > 0.1$. Then to the value of three independent variables $VIF < 10$, so it can be concluded that the regression model multicollinearity problem does not occur.

c. Heteroscedasticity Test

Results of testing heteroscedasticity are as follows:

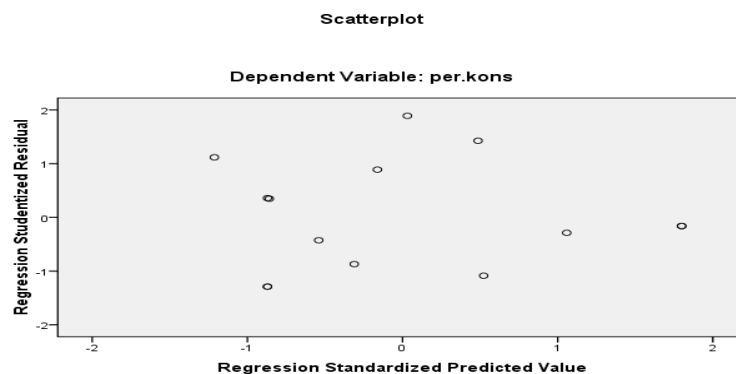

Fig 2. Heteroscedasticity Test

Decision-making method on heteroscedasticity test by looking at the scatterplot that if the points spread with no clear pattern above and below the 0 on the Y axis, it can be concluded that there is no problem of heteroscedasticity in regression models. Based on the table above, it can be seen that the points spread with no clear pattern above and below the 0 and the Y-axis, it can be concluded that the regression model does not occur heteroscedasticity problem.

4. Linear Regression Analysis

a. Regression Equation

The results of multiple linear regression analysis are shown in Table 8 below.

Table 8. Linear Regression Calculation Result

Variables	Coefficient (beta)	t hitung	Signifikansi
Constant	-1,372	-0,640	0,536
Sanitary-hygiene	0,422	3,870	0,003
Process Control	0,266	0,726	0,484
Control Management	-0,021	-0,055	0,957

Based on the calculation of linear regression according to table 8 above, the model obtained regression equation as follows:

$$Y = -1.372 + 0.422 X_1 + 0.266 X_2 - 0.021 X_3$$

With:

Y = Consumer Behavior

X₁ = sanitation-hygiene

X₂ = Process Control

X₃ = Control Management

Based on the multiple linear regression equation obtained, it can be seen that the rate of -1.372 indicates that in the absence of sanitation-hygiene variables, process control, and management oversight or if all the variables the value 0, then the behavior of the

consumer to determine the decision to buy mi iris value to fall by 1,372 . Figures 0.422 indicates that the sanitary-hygiene variables have coefficients that is positive. This suggests that the increase in sanitation-hygiene variables have a proportional relationship to the dependent variable (consumer behavior). If the sanitary-hygiene variables up one unit and other variables constant, the consumer behavior to determine buying decisions mi iris to increase by 0.422. Figures 0.266 indicates that the process control variables have coefficients that is positive. This suggests that the increase in process control variables have a proportional relationship to the dependent variable (consumer behavior).

If the variable process control up one unit and other variables constant, the consumer behavior to determine the decision to buy mi iris to increase by 0.266. -0.021 Figures show that the management control variables have coefficients that are negative. This suggests that the increase in supervisory management variables have a relationship which is inversely proportional to the dependent variable (consumer behavior). If the variable ride control management of the unit and other variables constant, the consumer behavior to determine the buying decision will slice noodles decreased by 0,021.

b. Coefficient of determination (R²)

The coefficient of determination are shown in Table 9 below:

Table 9. Value of coefficient of determination Model	R	R Square	Adjusted R Square	Std. Error of the Estimate
1	0,914 ^a	0,835	0,786	0,625

Adjusted R Square value of 0.786 means that the percentage of influence of the independent variables, namely sanitary-hygiene, process control, and management oversight of the dependent variable, namely consumer behavior mi is equal to 78.6% slice, while the remaining 21.4% is influenced by other factors were not examined.

c. Simultaneous Test (Test F)

Tests conducted with the following hypothesis.

H₀ = Variable sanitation-hygiene, process control, Control Management and management jointly not significantly influence consumer behavior sliced noodles.

H_a = Variable sanitation-hygiene, process control, Control Management and management together significantly influence consumer behavior sliced noodles.

Table 10.

Calculated F value

Model	F	Sig.
Regression	16,905	0,000 ^a

Based on the table above, note that the calculated F value of all independent variables (sanitary-hygiene, process control, and management oversight) sebesar 16,905 > F (3,71) or Sig. (0,000) ≤ alpha (0.05), then H₀ is rejected and H_a accepted. Means that all independent variables (sanitary-hygiene, process control, and management oversight)

jointly (simultaneously) significantly affect its dependent variable (consumer behavior sliced noodles).

d. Donations Predictors

Donations are used to determine predictors of how donations (contributions) of each independent variable. There are two types of contributions, namely the effective contribution (SE) and relative contribution (SR). Effective contribution amount for all variables equal to the coefficient of determination, whereas the relative contribution amount for all the independent variables are equal to 1 or 100% (Hadi, 2001). Calculation results predictor donations are as follows:

1) Effective Contribution (SE%)

a. Sanitation-Hygiene (X1)

$$SE (X_1)\% = \beta_{x1} \times r_{xy1} \times 100\% = 0.755 \times 0.904 \times 100\% = 68.252\% = 68.25\%$$

b. Process Control (X2)

$$SE (X_2)\% = \beta_{x2} \times r_{xy2} \times 100\% = 0.213 \times 0.752 \times 100\% = 16.0176\% = 16.02\%$$

c. Management Control Management (X3)

$$SE (X_3)\% = \beta_{x3} \times r_{xy3} \times 100\% = -0.013 \times 0.522 \times 100\% = -0.6786\% = -0.68\%$$

2) Relative Contribution (SR%)

a. Sanitation-Hygiene (X1)

$$SR (X_1)\% = \frac{SE (X_1)\%}{R^2} \times 100 \%$$

$$\frac{68,25 \ \%}{83,59 \ \%} \times 100 \ \%$$

$$= 81.65\%$$

b. Process Control (X2)

$$SR (X_2)\% = \frac{SE (X_2)\%}{R^2} \times 100 \%$$

$$\frac{16,02 \ \%}{83,59 \ \%} \times 100 \ \%$$

$$= 19.16\%$$

c. Control Management (X3)

$$SR (X_3)\% = \frac{SE (X_3)\%}{R^2} \times 100 \ \%$$

$$\frac{-0,68 \ \%}{83,59 \ \%} \times 100 \ \% = -0.81\%$$

CONCLUSION

Environmental effect of slice noodle's food toward consumer intermediate behavior is shown by the equation:

$$Y = -1.372 + 0.422 X_1 + 0.266 X_2 - 0.021 X_3$$

Priority in purchasing decisions of consumers sliced noodles in SME's Mr. Mulyono based relative value of the effective contribution and the largest, the sanitary-hygiene variables with the effective contribution of 68.25% and the relative contribution of 81.65%.

ACKNOWLEDGEMENT

I would like to thank for Nurul Fitria Hildanita to support this research for cooperation and assistance in the completion of this study and Mr.Mulyono for support object area industry Slice Noodle in Klisat, Pundong, Bantul.

REFERENCES

- National Agency of Drug and Food Control (2012). Guidelines for Food Production Way Good For Household Industry (CPPB-IRT), 2012. (30 Maret2012).
- Hadi, Sutrisno. (2001). Regression Analysis. Andi Offset, Yogyakarta.
- Jenie. (1996). "Sanitation in the Food Industry", in a set of Food Safety Short Course Handout. Inter-University Centre of Food and Nutrition, University of Gadjah Mada, Yogyakarta.
- Kotler, Philip and Keller, Kevin Lane. (2009). Marketing Management. The twelfth edition, vol 1. PT index, Indonesia.
- Purnamawati, Heni and interested. (2007). Cultivation 8 superior crops. Self spreader, Jakarta.
- Purnawijayanti, Hiasinta A. (2001). Sanitation, Hygiene, and Safety in Food Processing. Publisher Canisius, Jakarta.
- Rangkuti, Freddy. (2002). Techniques Creating Customer Values Based Marketing Plan and Analysis Case. PT Gramedia Pustaka Utama, Jakarta.
- Rukmana, Rahmat and Yuniarsih, Yuyun. (2001). Assorted Processed Cassava. Canisius, Yogyakarta.
- Santoso, Singgih. (2005). SPSS and Excel for Measuring Consumer Attitudes and Satisfaction. PT Elex Media Komputindo, Jakarta.
- Saparinto, Cahyo. (2006). Food Additives. Publisher Canisius, Yogyakarta.
- Simamora, Bilson. (2002). Consumer Behavior Research Guide. Third mold. PT Gramedia Pustaka Utama, Jakarta.
- Soekartawi. (2001). Introduction to Agro. King Grafindo PT Persada, Jakarta.
- Sudarmanto, R.Gunawan. (2005). Multiple Linear Regression Analysis with SPSS. Housekeeping Science, Yogyakarta.
- Welirang, Franky. (2008). Cassava Food Solutions Pemberagaman Independence. Grasindo, Jakarta.

APPLICATION OF AGRICULTURAL WASTE TO REDUCE INORGANIC FERTILIZER AND IMPROVE SUGARCANE PLANT RESISTANCE TO STEM BORER ATTACK

R.R. Rukmowati Brotodjojo^{1*}, Oktavia S Padmini², Saefudin Saeroji³

^{1,2}Department of Agrotechnology, Faculty of Agriculture, Universitas Pembangunan Nasional "Veteran" Yogyakarta, Indonesia

³Research Center PT. Gunung Madu Plantation, Lampung, Indonesia

Email: brotodjojo@upnyk.ac.id (*)

ABSTRACT

Stem borer attack is one of the limiting factors in the production of sugar cane. Proper management of plant nutrients to improve soil productivity could also improve plant resistance to borer attack and increase the yield of sugar cane. The aim of this research is to study the effect of fertilizer and boiler ash application in improving sugar cane plant resistance to stem borer attack. A Split-Split-Plot field experiment was arranged in a Randomized Completely Block Design with three replicates. The main plot was inorganic N, P, K fertilizer (standard dose, 2/3 standard dose, 1/3 standard dose). The sub plot was boiler ash application (80 tons/ha boiler ash and without boiler ash). The sub-sub plot was type of Liquid Organic Fertilizer (LOF) (LOF "Bacteria", LOF "Double" and LOF "Plus", no LOF application). Field observation was conducted on 4 months old plant to examine the percentage of stalk attacked and percentage of internodes damaged by stem borer. Artificial infestation in laboratory was conducted to examine biological performance of *Chilo auricilius* on treated plants. The application of low dose of inorganic N, P, K resulted in significantly lower incidence of sugar cane infested by stem borer. Application of boiler ash could increase sugar cane resistance by reducing first instar larvae survival and reducing third instar larval growth. The application of LOF "Plus" could increase the resistance of sugar cane against stem borer attack by reducing third instar larval growth and decreasing the damage on treated plant.

Keywords: stem borer, sugar cane, resistance

INTRODUCTION

Stem borer *Chilo auricilius* Dudg. is one of key pests of sugar cane in Indonesia (Sallam *et al.*, 2010). Year round cane cultivation in PT. Gunung Madu Plantation causes this pest always present in the field (Saefudin & Sunaryo, 2010). Crop yields and sucrose content in sugar cane could decrease significantly because of borer infestation. Observation on 11 months old cane in Gunung Madu Plantation, Lampung showed that stem borer infestation of 16-20% and 46-50% reduced sugar content by 0.91% and 2.26%, respectively. However, borer infestation up to 50% did not significantly reduce

weight, length and % cane juice (Saefudin, 2012). Borer's infestation on two months old cane could reduce sugar content by up to 97% (Mardiyani, 2012).

There are various control methods can be applied to reduce borer's infestation in sugar cane, including the use of resistant varieties. However, some resistant varieties have lower sugar content than the susceptible ones that are not favored by growers. Therefore, there is a need to improve the resistance of high yielding susceptible varieties against borer's infestation. Plant resistance to pest attack can be improved by providing appropriate nutrients. Silicon (Si) has been identified to increase plant resistance to pests and diseases (Savant *et al.*, 1999; Datnoff *et al.*, 2005; Laing & Adandonon, 2005; Meyer & Keeping, 2005). In plant, Si is deposited in cell wall served as physical and mechanical barrier. It is also involve in developing plants resistance against multiple stresses through metabolic and/or physiological activities (Liang *et al.*, 2007).

Several studies have shown that application of Si rich materials increase sugar cane resistance to borer attack. Application of bagasse furnace ash and silica slag significantly reduced the incidence of borer damaged in sugar cane treated plots than untreated control plot (Pan *et al.*, 1979). Other studies showed that application of different sources of Si increased sugar cane resistance to the stem borer *Diatraea saccharalis* F. (Anderson and Sosa, 2001), *Eldana saccharina* Walker (Keeping and Meyer, 2003; Meyer and Keeping, 2005; Kvedaras & Keeping, 2007; Kvedaras *et al.*, 2007) and to shoot borer *Scirpophaga nivella intacta* Snellen (Saefudin & Sunaryo, 2010).

Boiler ash is an agricultural waste from the combustion of bagasse generated in the sugar production process. Boilers ash contains 71 % SiO₂, 2.4 % P₂O₅, 9 % K₂O, 4 % CaO and several micro nutrients (2.3 % Na₂O, 3.1 % Al₂O₃, 3.7 % Fe₂O₃ dan 3.2 % MgO) (Disbunjatim, 2011). Boiler ash from Gunung Madu Plantation contains silicon 7.97 ± 0.58% (Saefudin & Sunaryo, 2010). Application of boiler ash can increase the nutrient content of the soil when applied together with manure or compost, besides the high content of silicon can increase plant resistance to pests and diseases. In addition, applying boiler ash to the field will reduce the amount of sugar factory waste disposal.

Sugarcane is a crop that requires a lot of fertilizer to produce high yield with high sugar content. Inorganic fertilizer may supply the needs of macro nutrients, such as nitrogen, phosphate and potassium. However, the use of excessive dose of inorganic fertilizer could lower the soil quality. Consequently, plants do not respond to fertilization, despite increased doses of inorganic fertilizers, and increasing crop productivity is not comparable to the addition of fertilizer intake (Adiningsih, 2006; Padmini, 2010). On the other hand, organic fertilizer provides macro and micro nutrient only in a modest level, but has less negative impact to the environment. Therefore, there is a need to balance the use of inorganic and organic fertilizer.

To improve soil productivity, improve efficiency of inorganic fertilizer use, as well as increase sugarcane production and yield, environmentally friendly cultivation technology can be applied by improving soil biology system and utilizing agricultural waste. Agricultural waste can be processed into liquid organic fertilizer and then used to add nutrients and plant hormones. Proper fertilization can accelerate and strengthen the growth and development of plants, increase resistance to certain pests and diseases, and thus improve plant production (Thompson and Troeh, 1978). This research aims to

study the effect of inorganic and liquid organic fertilizer and boiler ash application on sugar cane resistance to stem borer attack.

MATERIALS AND METHODS

A Split-Split-Plot field experiment was arranged in a Randomized Completely Block Design with three replicates. The Main plot was inorganic N, P, K fertilizer consisted of 3 levels, i.e., standard dose (N: 300kg/ha, P: 200 kg/ha, K: 300kg/ha), 2/3 standard dose (N: 200kg/ha, P: 200 kg/ha, K: 133 kg/ha), 1/3 standard dose (N: 100kg/ha, P: 67 kg/ha, K: 100kg/ha). The Sub plot was boiler ash application consisted of 2 levels, i.e., 80 tons/ha boiler ash and without boiler ash. The sub-sub plot was type of Liquid Organic Fertilizer (LOF) consisted of 4 levels, i.e., no LOF application, LOF Bacteria, LOF “Double” and LOF “Plus”. The LOF was applied once a month at concentration 20 mL/L until the plant was 4 months after planting.

Field observation was conducted on 4 months old plant to examine the percentage of stalk attacked by stem borer and percentage of internodes damaged by stem borer. For each plot, six sampling points was selected randomly. Number of total plants and number of infested stalks were counted in 1 m of selected rows. Two infested stalks from each sampling points were split longitudinally to count the number total internodes/stalk and number of internodes damaged.

In addition, cane stalk of each treatment was cut for artificial infestation in the laboratory. The spindle (rolled leaf) was cut 8 cm long and infested with 20 first instar larvae (L1) of stem borer (*C. auricilius*) then kept in a glass tube. The upper part of stalk (the 4th fully open leaf from top) was cut 6 cm long. The top and the bottom part of the upper stalk cut were covered with aluminum foil to prevent the larvae to bore into the open cut. Two third instar (L3) stem borer larvae were introduced in the leaf insertion (throat), and then kept in a plastic tube. The middle part of stalk was cut 6 cm long and bored longitudinally in the middle of stalk. Two third instar (L3) stem borer were infested through the hole, then kept in a plastic tube. The infested stalk cuts were incubated (t: 30±2 °C) for four days. The number of larvae (L1 and L3) died, number of leaf layer bored, weight of frass produced by L3, the length of bored stem and weight gain by L3 infested on stalk.

Collected data were analyzed using SAS® Software. Percentage data were transformed into $\text{Arcsin } \sqrt{x+1}$ before being analyzed. The data were subjected to Generalized Linear Model (GLM) procedure followed by Duncan Multiple Range Test.

RESULTS AND DISCUSSION

A. Field Observation

Field observation showed that application of different dose of N, P, K fertilizer (inorganic), ash and different types of liquid organic fertilizer (LOF) did not significantly affect percentage of damaged internodes. However, percentage of stalk attacked by stem borer was significantly higher on cane treated with standard dose of N, P, K than that treated with 1/3 of standard dose, but was not significantly different from that treated with 2/3 of standard dose. The application of ash and different types of LOF did not significantly affect percentage of stalk attacked.

These results indicates that by lowered the input of inorganic fertilizer (N, P, K) could reduced the percentage of stalk attacked by stem borer. High dose of inorganic fertilizer, especially nitrogen fertilizer, could boost vegetative growth of plant but resulted in succulent tissue. This condition makes plant vulnerable to pest attacked. Previous study showed that fiber content of the cane reduced as the N application rate increased and thus increased the number of stalks and internodes damaged by *E. saccharina* (Coulibaly, 1990). Other study showed that *E. saccharina* larval survival, percentage internodes bored and percentage stalk length bored increased significantly with increasing levels of N (Keeping *et al.*, 2011).

However, percentage of stalk attacked and internodes damaged did not affected significantly by application of boiler ash that rich in Si and different types LOF (Table 1). It could be that Si deposition in young cane (4 month after planting) has not been able to suppress stem borer infestation. Previous study showed that Si content in stalk was lower than leaves that resulted in no significant effect of silicate applied on stalk borer damage (Camargo *et al.*, 2011).

Table.1: Stem borer infestation on 4 month plant cane

Treatment		Stalk attacked (%)	Damaged internodes (%)
N, P, K Dose	Standard dose*	35.0±2.2 a	21.4±0.8 a
	2/3 dose	32.8±1.4 ab	20.0±0.6 a
	1/3 dose	29.4±2.3 b	19.7±1.0 a
Boiler ash application	80 tons/ha	33.3±1.6 x	20.6±0.6 x
	No application	31.5±1.7 x	20.1±0.7 x
Liquid Organic Fertilizer	"Bacteria"	33.4±1.8 p	21.7±1.0 p
	"Double"	29.5±2.7 p	20.0±1.0 p
	"Plus"	33.7±3.0 p	19.4±1.1 p
	No application	33.1±1.9 p	20.4±0.5 p
Interaction		-	-

Standard dose*: N: 300kg/ha, P: 200 kg/ha, K: 300kg/ha

Means within a column followed by the same letter are not significantly different from one another as determined by Duncan's multiple range tests.

2. Laboratory Experiments

The mortality of L1 was significantly lower when they were infested on spindle (rolled leaf) of cane treated with 1/3 of standard dose of N, P, K than those infested on cane treated with higher dose. More L1 died when they were infested on spindle (rolled leaf) of cane treated with ash than those infested on cane without ash application. The mortality of L3 did not significantly affected by ash application or LOF application. However, the mortality of L3 was significantly higher when they were infested on upper part of cane stalk treated with 2/3 of standard dose of N, P, K than those infested on cane treated with full dose of N, P, K, but similar to those infested on cane with 1/3 of standard dose of N, P, K (Table 2).

Lower survival of newly hatched (L1) *C. auricilius* larvae occurred when they were infested on rolled leaves (spindle) from plant treated with higher dose of N, P, K fertilizer. This result is in contrary to the results of previous research that showed

increasing levels of N significantly increased larval survival (Keeping *et al.*, 2011). It could be because in this research the application of higher dose of N was also followed with higher dose of P and K. Phosphorous (P) has a role in energy generation, nucleic acid synthesis, photosynthesis and other physiological processes in plant (Vance *et al.*, 2003). Potassium (K) supports plant defence against abiotic and biotic stresses, including pest attack (Wang *et al.*, 2013).

Higher mortality of first instar *C. auricilius* larvae infested on spindle of cane treated with ash could be because the rolled leaf contains Si that hampered the young larvae to chew the epidermis of leaf tissue. Previous study showed that epidermal tissue of leaf bud, internodes and root band of sugar cane treated with calcium silicate had increased silica than untreated plant (Keeping *et al.*, 2008). Young larvae have fragile mandible, the presence of Si in epidermal tissue could damage the mandible (Savant *et al.*, 1999). Other study showed that cell wall of tissue culture deposited in silicic acid was thicker, contains cellulose and hemicelluloses per cell-wall unit area was larger (Nissan *et al.*, 2011). This Si content and cell wall structure served as mechanical barrier to young larvae to feed that lead to mortality.

However, this effect was less significant on larger larvae (L3). The mortality of L3 was similar whether they were infested on plant treated with ash or without ash. Dose of N, P, K and ash application did not significantly affect number of leaf sheath bored by L3. Number of leaf sheath bored by L3 infested on the upper part of stalk from cane without LOF application was not significantly higher than those treated with LOF "Double", but it was significantly higher than those treated with LOF "Bacteria" or LOF "Plus" (Table 2). Liquid Organic Fertilizer "Bacteria" contains a variety of soil microbes beneficial for soil health. Microorganisms' activity will generate residual and metabolic substances to form soil aggregates ideal for plant growth and ecosystem balance in the soil (Saraswati *et al.*, 2006). Besides containing nutrients LOF "Plus" also contains botanical pesticide thus increasing plant resistance to pests.

Table 2: Biological performance of *Chilo auricilius* on upper part of stalk and spindle of 4 month plant cane

Treatment		Mortality of L1 (%)	Mortality of L3 (%)	Number of Leaf Sheath Bored	Frass Weight (g)
N,P,K Dose	Standard dose*	51.8±3.4 a	9.1±2.1 b	3.1±0.4 a	0.019±0.002 a
	2/3 dose	54.5±3.8 a	14.2±2.9 a	3.7±0.4 a	0.016±0.001 a
	1/3 dose	43.4±2.0 b	9.6±1.8 ab	3.4±0.4 a	0.016±0.001 a
Boiler ash application	80 tons/ha	54.5±3.1 x	12.8±2.1 x	3.1±0.3 x	0.019±0.002 x
	No application	46.1±2.0 y	8.9±1.6 x	3.7±0.4 x	0.015±0.001 y
Liquid Organic Fertilizer	"Bacteria"	49.0±3.4 p	11.1±3.7 p	3.0±0.4 q	0.017± 0.001p
	"Double"	50.5±4.3 p	12.2±2.2 p	3.3±0.5 pq	0.015±0.001 p
	"Plus"	52.3±4.2 p	10.6±2.5 p	3.0±0.6 q	0.016±0.001 p
	No application	49.3±3.5 p	9.4±2.1 p	4.1±0.4 p	0.021±0.003 p
Interaction		-	-	-	-

Standard dose*: N: 300kg/ha, P: 200 kg/ha, K: 300kg/ha. Means within a column followed by the same letter are not significantly different from one another as determined by Duncan's multiple range tests.

Weight of frass (feces) produced by L3 infested on the upper part of stalk from cane treated with boiler ash was significantly higher than that produced by L3 infested on cane without ash application. Dose of N, P, K and LOF application did not significantly affect weight of frass produced by L3 (Table 2).

Silicon mostly was accumulated in epidermal tissue of internodes, but less dense in the underlying tissue (Keeping *et al.*, 2008). Therefore, once the larvae were able to penetrate they can consume the tissue. The L3 gain less weight when infested on the middle part of stalk from cane treated with ash than that infested on cane without ash application. Silicon appears to contribute to the reduced larval growth. This result is similar to other research on *Eldana saccharina* Walker (Kvedaras & Keeping, 2007) and *Diatraea saccharalis* (F.) (Sidhu *et al.*, 2013). Dose of N, P, K did not significantly affect larval weight gain (Table 3).

Table 3: Biological performance of *Chilo auricilius* on middle part of stalk of 4 month plant cane

Treatment		L3 Weight gain (g)	Length of Bored Stalk (mm)	Frass Weight (g)
N, P, K Dose	Standard dose*	0.069±0.002 a	42.2±1.2 a	0.031±0.001 a
	2/3 dose	0.065±0.002 a	42.5±1.3 a	0.029±0.001 b
	1/3 dose	0.066±0.003 a	44.4±1.0 a	0.028±0.001 b
Boiler ash application	80 tons/ha	0.064±0.002 y	43.1±0.9 x	0.030±0.001 x
	No application	0.069±0.002 x	43.1±1.0 x	0.029±0.001 x
Liquid Organic Fertilizer	"Bacteria"	0.065±0.002 q	43.0±1.4 p	0.029±0.001 pq
	"Double"	0.064±0.001 q	42.8±0.8 p	0.030±0.001 pq
	"Plus"	0.064±0.002 q	43.9±1.8 p	0.028±0.001 q
	No application	0.073±0.005 p	42.5±1.3 p	0.031±0.001 p
Interaction		-	-	-

Standard dose*: N: 300kg/ha, P: 200 kg/ha, K: 300kg/ha

Means within a column followed by the same letter are not significantly different from one another as determined by Duncan's multiple range tests.

The application of LOF seems to increase plant resistance to stem borer by reducing larval growth and feeding damage. The L3 gain more weight when infested on the middle part of stalk from cane without LOF application than that infested on cane treated with various types of LOF. L3 infested on the middle part of stalk from cane treated with LOF "Plus" produced significantly less frass than those infested on cane without LOF application, but it produced about similar weight of frass than that infested on cane treated with other types of LOF (Table 3).

Weight of frass (feces) produced by L3 infested on the middle part of stalk from cane treated with standard dose of N, P, K was significantly higher than that produced by L3 infested on cane treated with lower dose (Table 3). The fibre content of the cane decreased as the N application rate increased (Coulibaly, 1990). This made the larvae consumed more and produced more frass. However, this did not prolong the bored tunnel in internodes. Length of bored stalk did not affected significantly by N, P, K

dose, ash application and LOF application. Ash application did not significantly affect frass produced by L3 (Table 3).

CONCLUSION

The resistance of sugar cane to pest infestation and damage can be improved by plant nutrition management. The application of low dose of inorganic N, P, K in combination with boiler ash and LOF “Bacteria” or LOF “Plus” may increase the resistance of sugar cane toward stem borer attack. Application of boiler ash in combination with liquid organic fertilizer made of agricultural waste could support green agroindustry, by reducing and recycling the agroindustrial waste.

ACKNOWLEDGEMENT

This research was funded by Competitive Grant from Directorate General of Higher Education, Department of Education and Culture the Republic of Indonesia (Contract No. ST/06.A/V/2013/LPPM). The authors also thank PT. Gunung Madu Plantation for providing experimental sites and facilities.

REFERENCES

- Adiningsih. 2006. Peranan Bahan/Pupuk Organik dalam Menunjang Peningkatan Produktivitas Lahan Pertanian. Menghantarkan Indonesia menjadi Produsen Organik Terkemuka. Proceeding Maporina Workshop. Jakarta. pp. 37-48
- Anderson, D.L., Sosa, O. Jr. 2001. Effect of silicon on expression of resistance to sugarcane borer (*Diatraea saccharalis*). Journal of the American Society of Sugar Cane Technologists 21: 43-50.
- Camargo, M.S., Júnior, A.R.G., Korndörfer, G.H. 2011. Silicate fertilization in sugarcane: effects on soluble silicon in soil, uptake and occurrence of stalk borer (*Diatraea saccharalis*). Proceedings of the 5th International Conference on Silicon in Agriculture, Beijing, China, September 13-18, 2011.
- Coulibaly, K. 1990. Influence of nitrogen fertilization on the attack on sugar cane by the stalk borer (*Eldana saccharina* Walker). Sugar Cane: No. Spring, Supplement pp. 18.
- Disbunjatim. 2011 http://disbunjatim.co.cc/bahanorganik/potensi_limbah_sbg_bo.html, [Diakses pada tanggal 29 Maret 2011].
- Keeping, M.G., Meyer, J.H. 2003. Effect of four sources of silicon on resistance of sugarcane varieties to *Eldana saccharina* Walker (Lepidoptera: Pyralidae). Proceeding of the South African Sugar Technologists' Association 77: 99-103.
- Keeping, M.G., Kvedaras, O.L., Bruton, A.G. 2008. Epidermal silicon in the sugarcane stalk and resistance to the stalk borer *Eldana saccharina*. 4th International Conference on Silicon in Agriculture, Wild Coast Sun, South Africa, 26-31 October 2008. Abstract Book.

- Keeping, M.G., Miles, N., Sewpersad, C., Sithole, S. 2011. The silicon: nitrogen interaction in relation to infestations of the stalk borer, *Eldana saccharina*, in sugarcane. Proceedings of the 5th International Conference on Silicon in Agriculture, Beijing, China, September 13-18, 2011.
- Kvedaras, O. L., Keeping M. G. 2007. Silicon impedes stalk penetration by the borer *Eldana saccharina* in sugarcane *Entomologia Experimentalis et Applicata* 125: 103-110.
- Kvedaras, O.L., Keeping, M.G., Goebel, F.R., Byrne, M.J. 2007. Water stress augments silicon-mediated resistance of susceptible sugarcane cultivars to the stalk borer *eldana saccharina* (lepidoptera: pyralidae). *Bulletin of Entomological Research* 97:175-83.
- Laing, M.D., Adandonon, A. 2005. Silicon and insect management – Review. Proceedings of the III Silicon in Agriculture Conference, Uberlândia/MG-Brazil, 22-26 October 2005: 35-44.
- Liang, Y., Sun, W., Zhu, Y., Christie, P. 2007. Mechanisms of silicon-mediated alleviation of abiotic stresses in higher plants: A review. *Environmental Pollution* 147: 422-428
- Mardiyani, P.P. 2012. Tekan Serangan Penggerek Pucuk & Batang Tebu: Efektifkan Arah & Jarak Pemasangan Pias. (In Indonesian). http://Ditjenbun.Deptan.Go.Id/Bbp2tpsurr/Index.Php?Option=Com_Content&View=Article&Id=241:Tekan-Serangan-Penggerek-Pucuk-A-Batang-Tebu-Efektifkan-Arah-A-Jarak-Pemasangan-Pias-&Catid=14:Proteksi&Itemid=25. Downloaded at 18 February 2012.
- Meyer, J.H., Keeping, M.G. 2005. An overview of the impact of silicon in alleviating biotic and abiotic stress in sugarcane. Proceedings of the III Silicon in Agriculture Conference, Uberlândia/MG-Brazil, 22-26 October 2005: 57-70.
- Nissan, H., Moshelion, M., Elbaum, R. 2011. The influence of silica on cell-culture growth parameters and cell-wall construction. Proceedings of The 5th International Conference on Silicon in Agriculture, September 13-18, 2011 Beijing, China.
- Padmini, O. S. 2010. Peran Pupuk Organik dalam Rotasi Tanaman Berbasis Padi Berkelanjutan Mendukung Ketahanan Pangan Nasional. (In Indonesian). Proceeding of National Seminar on Food Security, Yogyakarta, 2 Desember 2010
- Pan, Y.C., Kuroshio, K., Hokama, Y. 1979. The effect of bagasse furnace ash on the growth of plant cane. *Sugar Journal* 42: 14-16.
- Saefudin and Sunaryo. 2010. Studi pengaruh aplikasi abu bagas terhadap hama penggerek pucuk tebu, *Scirpophaga nivella intacta* snellen (Lepidoptera : Pyralidae) (In Indonesian). Proceeding of National Seminar 40th PEI (Indonesian Entomological Society): 530-538.
- Saefudin. 2012. Pengaruh intensitas serangan penggerek batang terhadap penurunan kualitas tebu. Research and Development of Gunung Madu Plantation, Lampung Internal Report (In Indonesian; Unpublished).

- Sallam, N., Achadian, E., Kristini, A., Sochib, M., Adi, H. 2010. Monitoring sugarcane moth borers in Indonesia: Towards better preparedness for exotic incursions. *Proceeding of Australian Society Sugar Cane Technologist* 32: 181-192.
- Savant, N. K., Korndorfer, G. H., Datnoff, L. E. and Snyder, G. H. 1999. Silicon nutrition and sugarcane production: A review. *Journal of Plant Nutrition* 22 (12):1853-1903
- Thompson, L.M., and F.R. Troeh. 1978. *Soil and Soil Fertility*. Mc graw-Hill Book.Co. New York.
- Vance, C.P., Uhde-Stone, C., Allan, D.L. 2003. Phosphorus acquisition and use: critical adaptations by plants for securing a nonrenewable resource. *New Phytologist* 157: 423–447
- Wang, M., Zheng, Q., Shen, Q., Guo, S., 2013. The Critical Role of Potassium in Plant Stress Response. *International Journal of Molecular Sciences* 14: 7370-7390.

CLIMATIC FACTOR IN EPIDEMIC OF VASCULAR STREAK DIEBACK OF COCOA

Herry Wirianata, Suprih Wijayani, and Elisabeth Nanik K.
Agriculture Institute of STIPER, Yogyakarta
e-mail herry_wirianata@yahoo.co.id.

ABSTRACT

Vascular streak dieback, caused by the fungus *Oncobasidium theobromae* (Talbot & Keane), is a disease of high economic importance in Indonesia. The disease affects both young seedlings and mature cocoa trees and in several provinces of Indonesia. In high infection, it causes plant death. This study was conducted to obtain the relationship between weather condition and disease epidemics. The results showed that the basidiospore are dispersed up to 350 m from diseased cocoa trees. Disease severity was closely correlated with rainfall incidence a few months earlier, high incidence disease and fungus sporulation was observed in high humidity.

Key words : vascular streak dieback, disease epidemic, and weather conditions.

INTRODUCTION

Vascular streak dieback (VSD) is a very damaging disease of cocoa in South East Asia. In Indonesia, it reached epidemic in the 2000s, It spreads at almost entire cocoa growing area this country, detroying plantation and preventing the establishment of new planting (Halimah & Sri Sukamto, 2007). VSD was destroyed cocoa industry in Papua New Guinea at early 1960s ant reached epidemic ten years later. It killed 100% susceptible cocoa clones (Efron *et al.*, 1999).

The most characteristic initial symptom of VSD is the chlorosis of a single leaf, usually on the second or third flush behind the shoot apex, with scattered islets of green tissue 2-5 mm in diameter. Affected leaves are shed within a few days and symptoms progressively develop on adjacent leaves up and down the stem. Lenticels on infected trees usually become enlarged, causing roughening of the bark. Three blackened vascular traces are visible when the dry surface is scraped off scars resulting from the fall of the diseased leaves. When stems are split, infected xylem is visible as dark streaks within the vascular tissue. Eventually leaf fall occurs up to growing tip, which then dies. The fungus may spread internally to other branches and usually kill the tree if it spread to the trunk (Guest & Keane, 2007).

When an infected leaf falls during wet weather, hypha may emerge from leaf scar and develop into basidiocarps. This structure is visible as a white, coating over the leaf scar and adjacent bark. Basidia develop on the basidiocarps after evening rainfall. Prolonged period of wetness are required for basidiocarp formation, basidiospore release, dissemination, and infection of leaves. Thus, there is a critical link between weather conditions and infection period (Keane & Prior, 1992).

Regular pruning of infected branches about 30 cm below discoloured xylem is used in some plantation to reduced inoculum level. It prevents futher extension of infection (Guest & Keane, 2007). In a mature plantation in Java where highly trained workers detect and prune out infected branches every two weeks for nearly two years, the incidence of infected trees was kept below one percent. In contrast, in unpruned planting, disease incidence increased from about 30 to 90% in a 10 month period (Soekirman & Purwantara, 1992). However, regular pruning promoted vegetative growth of the tree and decreased pod yield.

This paper presented the role of climatic condition in development of VSD in cocoa plantation.

MATERIALS AND METHODS

This research was conducted at Indonesian Coffee and Cocoa Research Institute at Jember (climatic type was D according to Schmidt & Ferguson). The eight years-old-polyclonal cocoa trees were planted at Kaliwining Plantation (45 m above sea level) which was used as a plot trial. Basidiospore dissemination of VSD pathogen was evaluated at different distances from the source of inoculum (diseased tree plot), namely : 50, 100 150, 200. 300, and 350 m at four wind directions. Glass microscope slides covered with vaseline were placed vertically at the height of 2.5 m from ground surface. These slides exposed to the air over night and the trapped propagul observed in the morning by microscopy. This observation was replicated daily during two months (May-June). Climatic conditions were recorded during the observations, included temperature, relative humidity, rainfall, and wind velocity.

VSD disease severity was assessed by scoring the intensity of natural infection of the disease on the branches (Table 1). The canopy of each tree was divided into four quarters for sampling. Diseased branches were selected purposively to VSD assessment which represented by ten trees of six clones (KW 516, Sul 1, Sul 2, ICCRI 03, ICCRI 04, TSH 858). This assessment was conducted in two weeks interval. In addition, fungal sporulation was assessed daily by means of branch area covered of fungal colony after cutting off these branch.

Table 1. Scoring used for evaluation of VSD severity in the field

Score	Disease category	Symptom
0	Healthy	0 % infected
1	Very light	5% leaves infected
2	Light	5 – 10% leaves infected, chlorosis;necrosis leaves falling down, lenticel swelling
3	Moderate	10 – 25 % leaves infected, chlorosis/necrosis some leaves falling down, lenticel swelling
4	Moderately heavy	25 – 50% leaves infected, chlorosis/necrosis leaves falling down, lenticel swelling
5	Heavy	50 – 75% leaves infected, chlorosis/necrosis some leaves falling down, lenticel swelling, fruit body present
6	Very heavy	75% leaves infected, chlorosis/necrosis leaves falling down, lenticel swelling, some fruit body present, branches dried.

Sources: Halimah & Sri-Sukamto (2007)

The relation of spore dispersal and air humidity and temperature was determined by correlation analysis.

RESULTS AND DISCUSSION

VSD epidemic of cocoa is related to inoculum production and dispersal at field. The gradient distance from diseased cocoa trees influences spore dispersal and disease severity as shown in Table 2.

Table 2. Basidiospore dispersal of *O. theobromae* at different distances from diseased tree.

Distance from source of inoculum (m)	Basidiospore/night
Close to source of inoculum	19.87
50	5.30
100	4.57
150	2.57
200	0.94
250	0.43
300	0.22
350	0.03

Table 2 shows that spore numbers decreased with an increasing gradient in distance from source inoculum. At distance of 350 m, spore were still detected. There were slight differences in spore detected at different distances in comparison to prior observations.

Table 3. Air humidity and temperature and arrested basidiospore of *O. theobromae*

Day to ..	Basidiospore/night	Humidity (%)	Temperature (°C)	Day to ..	Basidiospore/night	Humidity (%)	Temperature (°C)
1	4.41	97.41	24.24	16	4.78	98.15	24.56
2	2.97	88.82	24.08	17	4.81	97.77	24.12
3	3.47	97.74	24.60	18	5.09	96.08	24.13
4	4.16	80.71	24.77	19	4.19	98.08	24.63
5	4.94	83.07	23.87	20	3.81	97.54	23.53
6	4.63	83.07	24.52	21	2.81	95.15	23.17
7	4.50	97.00	23.51	22	3.34	95.92	23.28
8	2.25	97.85	23.66	23	4.72	96.00	24.32
9	3.06	98.15	23.35	24	5.09	97.77	22.90
10	4.28	98.23	22.89	25	5.52	98.08	23.12
11	4.31	98.85	24.44	26	4.47	97.00	23.81
12	4.88	98.10	23.79	27	4.47	96.69	23.59
13	4.53	96.00	24.44	28	7.78	95.94	23.89
14	4.94	97.08	23.65	29	3.63	97.00	23.38
15	4.00	97.54	24.20	30	5.37	96.69	23.42

Keane and Prior (1992) stated that disease spread from infected cocoa into younger, healthy population occurs along a steep gradient, with very few infections occurring

beyond 80 m from diseased trees. Sri-Sukamto and Nur`Aini (2012) found that spore dispersal can reach to 320 m from a source of inoculum. However, spore numbers were higher than in our observations.

The results showed that there were no close correlations between basidiospore dispersal and humidity nor with temperature at night as shown by R^2 : 0,32. Nevertheless, high humidity is suitable condition for VSD development in cocoa plantations. High humidity at night is required for basidiospore release, dissemination, and infection of leaves. The humidity remains over 90% for almost of all observations. The effective spore dispersal is probably limited to a few hours of high humidity following their discharge from basidiocarp. Wind speed was not recorded of all observation but it does mean that there is no windblown in the night. Quiet air condition caused spore down at speed of 0,5-20 mm/second (Halimah & Sukamto, 2007). Keane & Turner (1971) stated that spores of *O. theobromae* are wind-borne and can cause the infection if wind blowing gently.

Field observations showed that VSD severity was different between cocoa clones. In addition, disease severity were higher in initial observations and became lower as shown in Table 4.

Table 4. VSD disease severity of some cocoa clones.

Observation (two weeks interval)	Cocoa clones					
	KW 516	Sul 1	Sul 2	ICCRI 03	ICCRI 04	TSH 858
1	2.90	2.20	2.90	1.00	1.00	1.70
2	1.30	1.00	1.40	1.00	1.50	2.40
3	1.00	1.00	1.20	1.00	1.00	1.20
4	1.00	1.00	1.60	1.00	1.30	1.10
5	1.10	1.00	1.60	1.00	1.30	1.10
Mean	1.46	1.24	1.74	1.00	1.22	1.50

Higher disease severity in the initial observations were related to weather conditions, especially three until five months previously (January-March) when rainfall still occurred. At subsequent observations, the disease rate was lower and resulted from cultural efforts to prevent VSD epidemic. Diseased branch were pruning regularly in order to removal the source of inoculum. Shade and canopy management to increase aeration and sunlight interception on foliage is of critical importance as sporulation and infection require moist condition. In addition, these result showed that ICCRI 03 and ICCRI 04 have lowest severity and more resistant than the other clones. Nevertheless, Susilo & Anita (2011) indicated that these six clones appeared to be potential resistant ones that have good potential for VSD resistance breeding programme.

CONCLUSIONS

Based on the result of the observation, it concluded that : 1) spore dispersal can reached to 350 m at distance from the source of inoculum; 2) high humidity along the night is very important in VSD epidemics; and 3) the six cocoa clones have potential resistance to VSD control.

REFERENCES

- Efron, Y., P. Espaina, M. Fraure & J. Marfu, 1999. An Overview of PNG's Experience in Breeding and Improvement of Cocoa, Selection for Resistance and Quality in Cocoa In Indonesia. ACIAR.
- Guest, D. & P. Keane, 2007. Vascular Streak Dieback : A New Encounter Disease of Cacao in Papua New Guinea and Southeast Asia Caused by the Obligate Basidiomycete *Oncobasidium theobromae*. *Phytopathology* 97 (12) : 1654-1657.
- Halimah & Sri-Sukamto, 2007. Intensitas Penyakit Vascular Streak Dieback pada Sejumlah Klon Kakao Koleksi Pusat Penelitian Kopi dan Kakao. *Pelita Perkebunan* 23 (2) : 118-128.
- Keane, P.J. & P.D. Turner, 1971. Vascular Streak Dieback of Cocoa in West Malaysia. *Proc. Conf. Cocoa and Coconut*. Incorporated Society of Planers, Kuala Lumpur.
- Keane, P.J. & C. Prior, 1992. Biology of vascular dieback of cocoa. In P.J. Keane & C.A.J. Putter (Eds.) *Cocoa Pest and Disease Management in South-East Asia and Australasia* : 75-83. FAO Plant Production and Protection Paper No. 112. Rome.
- Soekirman, P. & A. Purwantara, 1992. Occurance and control of VSD in Java and South-East Sulawesi. In P.J. Keane & C.A.J. Putter (Eds.) *Cocoa Pest and Disease Management in South-East Asia and Australasia* : 209-213. FAO Plant Production and Protection Paper No. 112. Rome.
- Sri-Sukamto & F. Nur`Aini, 2012. Study of Dispersal of *Oncobasidium theobromae* as An Agent of Vascular Streak Dieback Disease. Paper presented in ICCRI. 6p.
- Susilo, A.W. & I. Anita-Sari, 2011. Respons Ketahanan Beberapa Hibrida Kakao (*Theobroma cacao* L.) terhadap Serangan Penyakit Pembuluh Kayu (Vascular Streak Dieback). *Pelita Perkebunan* 27 (2) : 77-87.

THE EFFECTIVENESS OF SEVERAL DOSAGES OF SOUR-SOP (*Annona muricata* L.) LEAVES AND SEEDS POWDER FOR CONTROLLING *Callosobruchus* sp. AND MAINTAINING THE QUALITY OF MUNGBEAN STORED SEEDS

Ami Suryawati*, Chimayatus Solichah.

Study Programme of Agrotechnology, Agriculture Faculty,
University of Pembangunan Nasional “Veteran” Yogyakarta
Email : ami_suryawati@yahoo.com

ABSTRACT

The aims of the experiment was to determine the optimum dosage of sour-sop leaves and seeds powder for decreasing *Callosobruchus* development and to maintain the quality of mungbean stored seed. The experiment was conducted at Plant Protection Laboratory, Faculty of Agriculture, UPN “Veteran” Yogyakarta from March to August 2013. It consisted of two factors: the part of sour-sop plant’s powder: leaves, rib of leaves and seeds; and the dosages of sour-sop powder: 10, 20 and 30g/100g mungbean seeds and one control treatment: no sour-sop powder application. It was arranged in Randomized Completely Design with four replications. Data collected was subjected to an analysis of variance followed by DMRT at 5% significance level. The results showed that: 1) The dosage of sour-sop seed powder 30g/100g mungbean seeds had the highest of *Callosobruchus* mortality (75%) on 96 hour after treatment and had better seed vigor than other combination treatments. 2)The sour-sop seed powder had the lowest *Callosobruchus* population and seedweight lost, on 1 and 2 month storage periods. 3) The quality of mungbean seed had decreased on 2 month storage period.

Keywords: *sour-sop powder, Callosobruchus* sp., *mungbean storage seeds*

INTRODUCTION

The production of mungbean is plagued by various pests, with insects causing the worst damage. The most important storage pest of mungbean is *Callosobruchus* spp. It belongs to the family Bruchidae. The larvae bore into the pea or bean throughout most of the tropics and subtropics (Hill and Waller, 1999). They develop inside kernel and feed on starchy interior. Adults hatch and making tunnel in the grain and continue to feed voraciously on the grain. They caused 50% seed weight loss of mungbean for 3 month (Priyono and Harahap, 1995).

Losses caused by storage pests include weight loss, loss in quality and market value, promoting of mould development, reduced germination in seed material and reduced nutritional value (Lowenberg- Deboer, 2003).

Insecticides, at the moment, are the best weapon against insect pest. Insecticides are chemical that affect the biological processes of many living organism and may act as

poisons to many animals' species (Hayes and Lawes, 1991). Insecticides have a wide range in mammalian toxicity, its toxic doses range from 1mg/kg in the diet of a vertebrate animal to very large amount, which are needed to kill a mammal (Hardy, 1990)

Although the pest can be effectively controlled by synthetic insecticides (Arthur 1996; Golob 1988), these insecticides cause serious problems of toxic residues, health and environmental hazards, in addition to development of insect resistance (Fishwick, 1988; Golob *et al.*, 1982; Yusof& Ho, 1992*cit.* Asmanizar *et al.*, 2012). The need for finding materials that are effectively protect rice grain which are readily available, affordable, relatively less poisonous and less detrimental to the environment had stimulated interest in the development of alternative method of control, such as using of botanical insecticide.

Botanical insecticides are getting the great interest, because they are natural insecticides, toxicants derived from plants. Since the use of chemicals has so many adverse effects on the environment, the botanical insecticides have been widely adopted by the farmers to control the insect pest that attack cowpea (Pereira *et al* 1982). The effectiveness of botanical insecticides has been demonstrated in many studies. Many of the plant species concerned have also been used in traditional medicine by local communities and have been collected from the field or specifically cultivated for these purposes. Leaves, roots, twigs and flowers have been admixed as protectant with various commodities in different parts of the world (Asmanizar *et al.*, 2012).

The laboratory evaluation of the repellency of two pepper varieties, *Capsicum annum* and *Caesium frutescens* (cayenne pepper) to cowpea weevil, *Callosobruchus maculatus* was carried out and found effective (Egwynyenga *et al.*, 2000).The plants of *Azadirachta indica* A. Juss (common name: neem) and *Citrus sinensis* (common name sweet orange) have been reported to have some insecticidal properties against pests (Taylor, 1975). For example *C. sinensis* pea powder has proved potentially against *C. maculatus*, depressing oviposition and progeny emergence on cowpea, although at high doses (Taylor, 1975).

Grain protectants are defined as pesticides which are incorporated directly into the grain mass for protection against insect. This is also known as admixture treatment. The advantage of insecticide are: generally easy in preparing, inexpensive and a single application of an effective insecticide, correctly formulated, giving control of existing insect infestation (including, eventually, any insect stages within the kernels) and protecting the grain against re-festation for a substantial period (Proctor, 1994). More information is needed regarding the effectiveness of the soursop leaves and sour-sop seeds powder in controlling *Callosobruchus* sp. and maintaining mungbean seed quality in storage.

MATERIALS AND METHODS

The experiment was conducted at Plant Protection Laboratory, Faculty of Agriculture, UPN "Veteran" Yogyakarta from March to August 2013. It consisted of two factors: the part of sour-sop plant powder: leaves, rib of leaves and seeds and the dosages of sour-sop powder: 10, 20 and 30g/100g mungbean seeds and one control treatment: no sour-sop powder application. It was arranged in Randomized Completely Design with

four replications. Data collected was subjected to an analysis of variance followed by DMRT at 5% significance level.

A. Bioassay (Mortality Test)

Each plastic glass contains, 50g seeds mixed with soursop powder, depended on the treatment. Ten (10) newly emerged adults of *Callosobruchus spp.* was introduced into plastic glass. The glasses were covered with fine fabric nets to ensure aeration. Percentage of mortality was calculated daily for four (4) days.

B. Evaluation of Seed Quality

After 2 months seed storage period, weight loss of mungbean seed was measured. For germination test, four replicated of 50 seeds from each treatment were planted on sand-filled germination bag, allowed to germinate for 7 days and then all germination test parameters were recorded.

C. Phytochemic tests

Polar fraction was analyzed by using ethanol and non-polar fraction by using n-hexan. Alcaloids were detected with Dragendorff and terpenoids with sulphate acid anisaldehyde. Phitochemic tests by Thin Layer Chromatography (TLC).

RESULTS AND DISCUSSION

Comparison between treatments and control were using Least Significant Difference and contrass orthogonal at 5% level. The result showed that mortality of *Callosobruchus spp.* occured on 48 hours. Weevil mortality on mungbean seeds treated with various powder of soursop was significantly difference on 78 and 96 hours after applications. Generally, the percentage of weevil mortality increased with the increasing of powder concentration tested on mungbean seed. The highest mortality was on 78 and 96 hours after applications occured on seed powder application (Table 1). The active compound of soursop powder needed longer time to penetrate insect cuticles, that's way significantly mortality occured on 72 hours after application. Seed powder caused higher mortality of *Callosobruchus spp.* than leaf and rib of leaf powder, because active compound of seed powder such as acetogenin, squamosin and annonain was higher than the others. Squamosin could depress respiration on mitochondria and spesificly depressed electron transfer.

The powder of *A. muricata* seed exhibited greater toxic effects against *C. chinensis* adult than *A. muricata*, indicating that the powder seeds contain chemical components that are not present in leaf. Dos Santos and Sant'Ana (2001) and Isman (2006) reported that the Annonaceous species such as *A. muricata* had the Annonaceous acetogenin, a class of natural compound with a wide range of biological activities. The acetogenin from *A. muricata* seed had been known to have substances that act as botanical insecticide (Leatemia & Isman 2004).

Table 1. Percentage of *Callosobruchus* sp mortality on 48, 72, 96 and 120 hours after application

Observation on 48 hours after application				
Part of soursop plant	Dosage of soursop powder per 100 g seeds			Means
	0,5 g	1,0 g	1,5 g	
Leaf	0,00	0,00	2,50	0,83 a
Seed	0,00	0,00	0,00	0,00 a
Rib of leaf	2,50	0,00	5,00	2,50 a
Means	0,83 j	0,00 j	2,50 j	1,11 x (-)
Untreated				0,00 x
Observation on 72hours after application				
Part of soursop plant	Dosage of soursop powder per 100 g seeds			Means
	0,5 g	1,0 g	1,5 g	
Leaf	2,50	0,00	2,50	1,67 c
Seed	17,50	20,00	30,00	22,00 a
Rib of leaf	15,00	12,50	17,50	15,00 b
Means	11,67 j	10,83 j	16,67 j	12,89 x (-)
Untreated				0,00 x
Observation on 96hours after application				
Part of soursop plant	Dosage of soursop powder per 100 g seeds			Means
	0,5 g	1,0 g	1,5 g	
Leaf	10,00 d	12,50 d	12,50 d	11,67
Seed	42,50 c	57,50 b	75,00 a	58,33
Rib of leaf	40,00 c	40,00 c	35,00 c	38,33
Means	30,83	36,67	40,83	36,11 x (+)
Untreated				10,00 y
Observation on 120hours after application				
Part of soursop plant	Dosage of soursop powder per 100 g seeds			Means
	0,5 g	1,0 g	1,5 g	
Leaf	37,50	32,50	32,50	34,17 a
Seed	80,00	75,00	77,50	77,50 a
Rib of leaf	60,00	57,50	57,50	58,33 a
Means	59,17 j	55,00 j	55,83 j	56,67 x (-)
Untreated				47,50 y

Note : Mean in column (P,Q,R) and row (a,b,c) followed by the same letters are not significantly different at 5% level Duncan test and Contrast Orthogonal; (-) no interaction

Table 2 showed that population of *Callosobruchus spp.* on 2 months storage on control (untreated) was higher than seed treated. Population of *Callosobruchus spp.* on seed powder treatment was lower than the others. Mortality of *Callosobruchus spp.* on seed powder treatment was higher than leaf and rib powder, so it could suppress oviposition of adult female and population growth. *A. muricata* seed contains acetogenins which could be contributed to the weevil mortality. The acetogenins from the family Annonaceae was reported to cause high mortality of German cockroach, *Blattella germanica* (Alali *et al.* 1998).

Plant powders have been used to suppress the population of storage pests (Ogunleye,2000.,Ogunleye *et al.*, 2004 and Onu and Baba, 2003). It has been reported that powders of plant materials are capable of blocking the spiracle of insects

(Steve,2010, Lale,2002). This can lead to suffocation and death. Secondly, these powders, when stocked under the wings of insects in the store complied with the fact that the plant has great itching effects are capable of causing great discomfort to them. This may prevent them from feeding well and eventually leads to death. It has been suggested that abrasions can lead the loss of fluids and consequently, death of insects and it may also significantly reduce the rate of oviposition (Ogunwolu *et al.*, 1998).

The high mortality rate could also be as a result of direct feeding of the insects on the plant materials. The insects are not able to derive enough nourishment that will support its normal growth and development from the plants and this may lead to insect mortality. It is also evident in this research work that *C. maculatus* is more susceptible to the adverse effects of the plant materials.

Table2. *Callosobruchus* sp population after 2 months seed stored

<i>Callosobruchus</i> sp adult population after 2 month stored				
Part of soursop plant	Dosage of soursop powder per 100 g seeds			Means
	0,5	1.0	1.5	
Leaf	117.00	165.75	217.50	166.75b
Seed	68.50	61.25	49.75	59.83a
Rib of leaf	121.75	160.25	122.25	134.75ab
Means	102.42j	129.08k	129.83k	120.44x
Untreated				253.00y

Note : Mean in column (P,Q,R) and row (a,b,c) followed by the same letters are not significantly different at 5% level Duncan test and Contrast Orthogonal; (-) no interaction

Table 3 showed the mungbean seed damage after 2 months in storage in the form of weight loss of seed. The mungbean seed damage increased with increasing their weight loss.

Table 3. Weight loss of mungbean seed after 2 months stored (%)

Weight loss after 2 month stored (%)				
Part of soursop plant	Dosage of soursop powder per 100 g seeds			Mean
	0,5	1.0	1.5	
Leaf	5.4576	3.9925	6.6115	5.3539a
Seed	4.4759	3.9255	4.7002	4.3672b
Rib of leaf	5.8332	7.0595	4.8667	5.9198a
Means	5.2556	4.9925	5.3928	5.2136x
Untreated				14.0365y

Note : Mean in column (P,Q,R) and row (a,b,c) followed by the same letters are not significantly different at 5% level Duncan test and Contrast Orthogonal; (-) no interaction

Weight loss on control was higher than treated seed because population of *C. chinensis* on control was higher than treated seed. Weight loss on treatment of seed powder was

lower than leaf and rib of leaf powder because the active compound of seed powder such as acetogenin, squamosin and annonain was higher than the others.

There was no significant effect of the part of sour-sop plant powder on the percentage of seed moisture content (Table 4.). There was also of the dosages of sour-sop powder for 2 months seed stored. The treatment and control had no significant effect on seed moisture content. It showed that the storage condition had no change RH and temperature.

Table 4. Seed Moisture Content after 2 months stored (%)

Part of soursop plant	Weight loss after 2 month stored (%)			Mean
	Dosage of soursop powder per 100 g seeds			
	0,5	1.0	1.5	
Leaf	9.33a	10.02ab	10.92ab	10.09
Seed	9.29a	9.31a	9.92ab	9.51
Rib of leaf	10.16ab	12.30b	8.49a	10.32
Means				9.97x
Untreated				10.88x

Note : Mean in column (P,Q,R) and row (a,b,c) followed by the same letters are not significantly different at 5% level Duncan test and Contrast Orthogonal; (-) no interaction

Seed treatment with seed sour-sop powder gave lower seed conductivity than leaves and rib sour-sop. (Table 5.) Seed sour-sop powder had higher alkaloid than their leaves and rib so can kept seed from *Callosobruchus* sp.

Conductivity test was based on the premise that as seed deterioration progresses, the cell membranes become less rigid and more water permeable, allowing the cell contents to escape into solution with the water and increasing its electrical conductivity. The conductivity of the solution reflected the general level of viability of seed (Copeland and Donald, 1995)

Table 5. Seed Conductivity after 2 months in storage (m Hos)

Part of soursop plant	Weight loss after 2 month stored (%)			Mean
	Dosage of soursop powder per 100 g seeds			
	0,5	1.0	1.5	
Leaf	2.0150	2.1143	2.6500	2.2598b
Seed	1.6728	1.7243	1.8410	1.7460a
Rib of leaf	1.9040	2.7690	2.2020	2.2917b
Means	1.8639	2.2025	2.2310	2.0991
Untreated				2.2713

Note : Mean in column (P,Q,R) and row (a,b,c) followed by the same letters are not significantly different at 5% level Duncan test and Contrast Orthogonal; (-) no interaction

As the result of seed conductivity, seed treatment with seed sour-sop powder had higher percentage of germination than their rib leaf (Table 6.). There had been decreasing percentage of seed germination on 2 months seed storage period.

Table 6. Percentage of germination after 2 months in storage (%)

Part of soursop plant	Weight loss after 2 month stored (%)			Mean
	Dosage of soursop powder per 100 g seeds			
	0,5	1.0	1.5	
Leaf	72.50	68.00	61.50	67.33ab
Seed	88.00	79.33	52.00	73.11a
Rib of leaf	80.75	50.50	32.50	54.58b
Means	80.42j	65.94k	48.47k	65.01
Untreated				59.00

Note : Mean in column (P,Q,R) and row (a,b,c) followed by the same letters are not significantly different at 5% level Duncan test and Contrast Orthogonal; (-) no interaction

There was interaction between the part of sour-sop plant powder and their dosages on percentage of seed vigor after 2 months seed storage period (Table 7.) The percentage of seed vigor showed its power germination velocity. The dosages 30g seed sour-sop powder had the better seed vigor than other combination treatment.

Table 7. Percentage of Seed Vigor after 2 months (%)

Part of soursop plant	Weight loss after 2 month stored (%)			Mean
	Dosage of soursop powder per 100 g seeds			
	0,5	1.0	1.5	
Leaf	61.00ab	76.50a	49.50bc	62.33
Seed	78.00a	70.00a	60.00ab	69.33
Rib of leaf	70.00a	38.50c	32.50c	47.00
Means	69.67	61.67	47.33	59.55
Untreated				56.00

Note : Mean in column (P,Q,R) and row (a,b,c) followed by the same letters are not significantly different at 5% level Duncan test and Contrast Orthogonal; (-) no interaction

Table 8. Phytochemic test on etanol and n-heksana fraction on rib of leaf, seed and leaf of soursop

Fraction of	Part of plant	Phytochemic test	
		Alcaloid	Terpenoid
Ethanol	Leaf	+	+
	Rib of leaf	+	+
	Seed	++	+
n-hexan	Leaf		
	Rib of leaf	+	+
	Seed	+	+
		++	++

Note : ++ : many compound
+ : less compound

Phytochemicals test have done to determine active compound on each soursop plant powder qualitatively. On ethanol and n-hexan extract showed that seed part was found many secondary metabolic such as alkaloid and terpenoid (Table 8.).

CONCLUSION

The conclusion were: 1) The dosage of sour-sop seed powder 30g/100g mungbean seeds had the highest of *Callosobruchus* mortality (75%) on 96 hour after treatment and better seed vigor than other combination treatments 2)The sour-sop seed powder had the lowest *Callosobruchus* population and seed weight loss on 1 and 2 month storage periods. 3) The quality of mungbean seed had decreased on 2 month storage period.

REFERENCES

- Alali, Q.F., Kaakeh, W., Bennett, G.W. & McLaughlin, J.L. 1998. Annonaceous acetogenins as natural pesticides: Potent toxicity against insecticide-susceptible and resistant German Cockroaches (Dictyoptera: Blatellidae). *Journal of Economic Entomology* 9(3): 641-649.
- Arthur, F.H. 1996. Grain protectant; current status and prospects for the future. *Journal of Stored Product Research* 32(4):293-302.
- Asmanizar, A. Djamin & A.B. Idris. 2012. Effect of Four Selected plant Powder as Rice Grain Protectant Against *Sitophilus zeamais* (Coleoptera: Curculionidae). *Sains Malaysiana* 41(7)(2012): 863–869.
- Copeland, L.O. and Miller, B.M. 1995. Seed Science and Technology. 3^{ed}. Chappman and Hall, Dept. B.C, 115 Avenue, New York. NY 10003.
- Dos Santos, A.F. & Sant'Ana, A.E.G., 2001. Molluscicidal properties of some species Annona. *Phytomedicine* 8: 115-120.
- Fishwick, F.B. 1988. Pesticide residues in grain arising from post harvest treatment. *Aspects of Applied Biology* 17: 37-46.
- Golob, P. 1988. Current status of larger grain borer, *Prostephanus truncatus* Horn, in Africa. *Insect Science and Its Application* 12: 737-745.
- Hill, D.S. & Waller, J.M.. 1999. *Pests and Disease of Tropical crop volume 2*. Field Handbook chapter 24 and 34 pg 258 – 267, 397 – 406, 202- 212, 258 – 267.
- Hayes, J. and Lewis. 1991. *Handbook of Pesticide toxicology* vol I, II and III, Academic Press, San Diego, London, Sydney, Toronto, 1527 pp.
- Hardly, A. R. 1990. Estimating exposure: the identification of species at risk and routes of exposure in: *Effects of pesticides Terrestrial wildlife* L. Somerville and C.H Walker (Eds) Taylor and Francis, London 81 – 97.
- Isman, M.B 2006. Botanical insecticide, deterrent and repellent in modern agriculture and increasingly regulated world. *Annual Review of Entomology* 51: 45-66.

- Lale, N.E.S. 2002. *Stored –Product Entomology and Acarology in Tropical Africa*. Pg 204. Mole Publications.
- Leatemala, J.A. & Isman, M.B. 2004. Toxicity and antifeedant activity of crude seed extract of *Annona squamosa*(Annonaceae) against lepidopteran pests and natural enemies. *International Journal of Tropical Insect Science* 24(2):150-158.
- Ogunleye, R.F., Adesuyi, S.A. and Adedire, C.O. 2004. Toxicity of some underutilized Tropical plants to the storage pest of maize, *Sitophilus zeamais* (Mots)(Coleoptera : Curculionidae). *Journal of Biological and Physical Sciences*. 2: 22-27.
- Priyono, D. dan Harahap, I.S. 1995. Aktivitas Insektisida Ekstrak Biji Sirsak (*Annona muricata* L.) Terhadap *Callosobruchus maculatus* (F.) (Coleoptera: Bruchidae). *Buletin HPT*, Vol. 8, No. 1, 1995. Bogor. Hal 43-46.

FIELD APPLICATION OF OBERON® AND ENVIDOR® ON *OLIGONYCHUS SACCHARI* (PROSTIGMATA: TETRANYCHIDAE) AND ITS PREDATOR *STETHORUS GILVIFRONS* (COLEOPTERA: COCCINELLIDAE)

Amin Nikpay^{1,2*}, Masoud Arbabi³, Peyman Sharafizadeh², Mahmood Poormahmood⁴

1 Entomology Department, Islamic Azad University, Arak Branch, Arak, Iran

2 Division of Plant Protection, Sugarcane & By-Products Development Company,
Salman Farsi Unit, Ahwaz, Iran

3 Laboratory of Acarology, Department of Agricultural Research Zoology, Iranian
Research Institute of Plant Protection, Tehran, Iran

4 Bayer CropScience Regional Representative, Ahwaz, Iran.

email: amin_nikpay@yahoo.com

ABSTRACT

Sugarcane yellow mite, *Oligonychus sacchari* (Prostigmata: Tetranychidae) is the most destructive pest in sugarcane growing area in tropics and subtropics. They colonize on the lower surfaces of sugarcane leaves. Being sporadic in nature is source of troubles for sugarcane crop in specific and local areas under sugarcane cultivation in Iran. Although the biological agent (*Stethorus gilvifrons*) is existed, this predatory beetle cannot control the mite populations under Economic Injury Level (EIL). The ability of high reproductive potential and multi-generation of this pest leads to a vulnerable candidate for developing pest resistance to conventional acaricides. This phenomenon will promote a high cost of application rate to sugar industry. Due to these reasons, experiments were conducted on chemical control of sugarcane yellow mite and the effect of these acaricides on predatory beetle *S. gilvifrons* using two commercial varieties CP48-103 and CP57-614 in sugarcane fields at Salman Farsi agro-industry unit in Ahwaz. Acaricide treatments were Oberon® (400 cc per hectare) and Envidor® (300 cc per hectare). Oberon's active ingredient is Spiromesifen. It belongs to a new class of chemicals called ketoneols. Oberon is a lipid biosynthesis inhibitor (LBI) and interferes with spider mite lipogenesis by preventing biosynthesis of fatty acids and subsequent biochemical derivatives. Envidor's active ingredient is Spirodichlofen. It belongs to class of chemicals called tetrionic acids and can affect endocrine system of mites and prevent production of energy. Each treatment was replicated three times for each commercial variety and control. The number of mites were recorded after 0 (before spraying), 3, 7, 15 and 30 days after application and predatory beetle were recorded after 10, 20, 30 and 40 days after treatments. The results revealed that there were significant difference between acaricides application and control. Oberon® and Envidor® were effective treatments after 30 days, but the acaricidal efficacy of both miticides were reduced and this phenomenon was attributed to high temperature during the tests. There was no difference among acaricides on predatory beetle at 10, 20, 30 and 40 days after application, after 10 days we recorded predatory beetles on both treated varieties and the number of beetles were increased with extended time.

Keywords: sugarcane yellow mite, *stethorus gilvifrons*, acaricides, economic injury level.

INTRODUCTION

Sugarcane, one of the most profitable crops, has been cultivated for many years under diverse ecological conditions in tropical and subtropical regions. This monoculture condition assists potential insect pests to colonize and affect the sugarcane quantity and quality (James, 2004). Spider mite infestations generally occur during late May- early August in Iran. The lower leaves of sugarcane are usually colonized first. However, prolonged heavy infestations accompanied by extensive damage to the middle and upper leaves of young plants reduce plant growth. Being sporadic in nature, it is a source of trouble to sugarcane crop in specific and localized areas under sugarcane cultivation. Usually in the summer months, large out-breaks of spider mites can occur in sugarcane fields located in south west Khuzestan province. Investigators were, of the opinion, that in severe infestation photosynthetic activity was adversely affected and crops appeared red/yellow due to fine webs (Singh *et al.*, 2003). Possible options for controlling this pest rely on chemical and botanical acaricides (Nikpay *et al.*, 2011; Nikpay *et al.*, 2012; Singh *et al.*, 2003), cultural practices (Leslie, 2004) and biological control with coccinellids beetles (Biddinger *et al.*, 2009).

Chemical acaricides have been relied; however, these are not always effective and their continuous use has resulted in resistance among *O. sacchari* populations due to its rapid life cycle and multiple generations. One of the most biological control agents of *O. sacchari* in Iranian sugarcane fields is *Stethorus gilvifrons* (Mulsant). In some conditions, this species can regulate mite populations. The reasons for this success include regulative potential of long-lived adults, the ability of adults to rapidly immigrate into sugarcane fields and various supporting systems such as floral, nectars, and pollen adjacent plants for *S. gilvifrons* populations before reaching mite populations outbreaks in crops (Afshari, 1999; Biddinger *et al.*, 2009). One aspect for effective and environmental-friendly out-put of acaricides is their side effects on natural enemies. Therefore, the objectives of the present study were to, 1. Assessment of two acaricides treatments on sugarcane yellow mite populations in different periods, and 2. Investigate the side effects of miticides applications on the predatory beetle *S. gilvifrons* (Coleoptera: Coccinellidae).

MATERIALS AND METHODS

For these research trials, we used two sugarcane cultivars: CP57-614 and CP48-103 which are sensitive to *Oligonychus sacchari* (Nikpay & Soleyman Nejadian, 2013). Cultivation included standard tillage, following by ridging at 1.8-m furrow spacing. The whole field was fertilized according to local fertilizer recommendations to amend for any nutrient deficiencies. Following planting of seed cane sets (on each furrow), all furrows were treated with Atrazine and Sencor herbicides, as a pre-emergence application (3+2 kg per hectare) for weed control.

A. Field trials and miticides applications

For these research trials, a randomized complete block design with three blocks was conducted at Salman Farsi Agro-Industry, Ahwaz-Iran from early June to early July 2012. Each experimental plot (block) consisted of four rows, 6 meters long and 1.8 meters spaced (between two furrows) in different points of the field. This plot

configuration was used for sugarcane experiments because plots for trials in sugarcane experimental design are recommended to be at least 20-m² (Laycock, 2004). The two cultivars were treated with two different liquid acaricides as foliar applications. These acaricide treatments were Envidor[®] (300 cc per hectare) and Oberon[®] (400 cc per hectare), which both produced by Bayer Crop Science (Germany). All treatments were applied as foliar applications by a 15-litre volume sprayer (Hardi International, England) at the rate of 300 cc and 400 cc per hectare for Envidor[®] and Oberon[®] in early-June and early-July 2012, respectively. Control plots received neither acaricides nor water (because water can affect and reduce mite populations). In each plot, fifteen leaves were selected at random from bottom, mid and top of plant. Samples were kept in plastic bags, returned to laboratory and number of living mites was recorded. Samples were viewed under a stereomicroscope (STZ800 Nikon, Tokyo, Japan) in order to be precise in counting. Samples were collected 3, 7, 15 and 30 days after application of acaricides. In order to assess the side effects of silicon treatments to the coccinellid beetle *S. gilvifrons* populations, the number of living beetles (both larvae and adults) was determined following the same procedures for determining mite numbers. Samples of *S. gilvifrons* were collected 10, 20, 30 and 40 days after application of acaricides, due to longer life cycle of beetles than mites. Since beetles are very active and can fly easily, recording of beetles was performed in the field.

B. Data analysis

All data were tested for normality and homogeneity of variance (Bartlett's test), and appropriate transformations (Log X and Log X+1) were applied when normal and homogeneity conditions were not met, before analysis of variance. All analyses were performed with SPSS software (SPSS version 16, SPSS International, Chicago, USA) and Tukey HSD test was used for comparisons between treatments.

RESULTS

The results of these experiments indicated that although the number of mites before application of the acaricides was high in all the plots, acaricides treatments significantly decreased sugarcane mite population even after 3 days of treatments. Population density of the mites up to 30 days was considerably lower than the control in both varieties. However, after 30 days of the commencement of the trials a few numbers of the mites was observed in all the treated plots (Figure 1). Acaricides application had negative impact on the population density of predatory beetles. However, after 40 days the number of predatory coccinellids was increased in the Envidor[®] and Oberon[®] treated plots (Figure 2). The performance of Envidor[®] and Oberon[®] in controlling mites and beetles does not significantly different in the field.

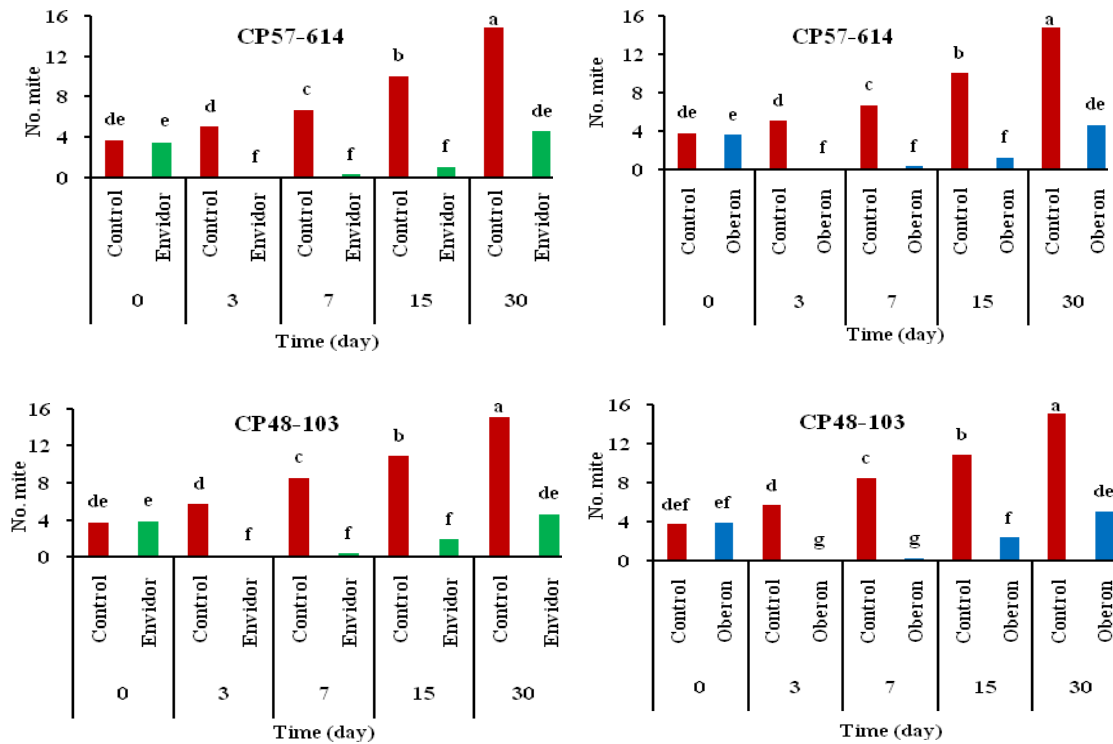

Fig. 1. Number of sugarcane mites exposed to Envidor[®] and Oberon[®] acaricides
Means followed by the same letters are not significantly different at $P < 0.05$.

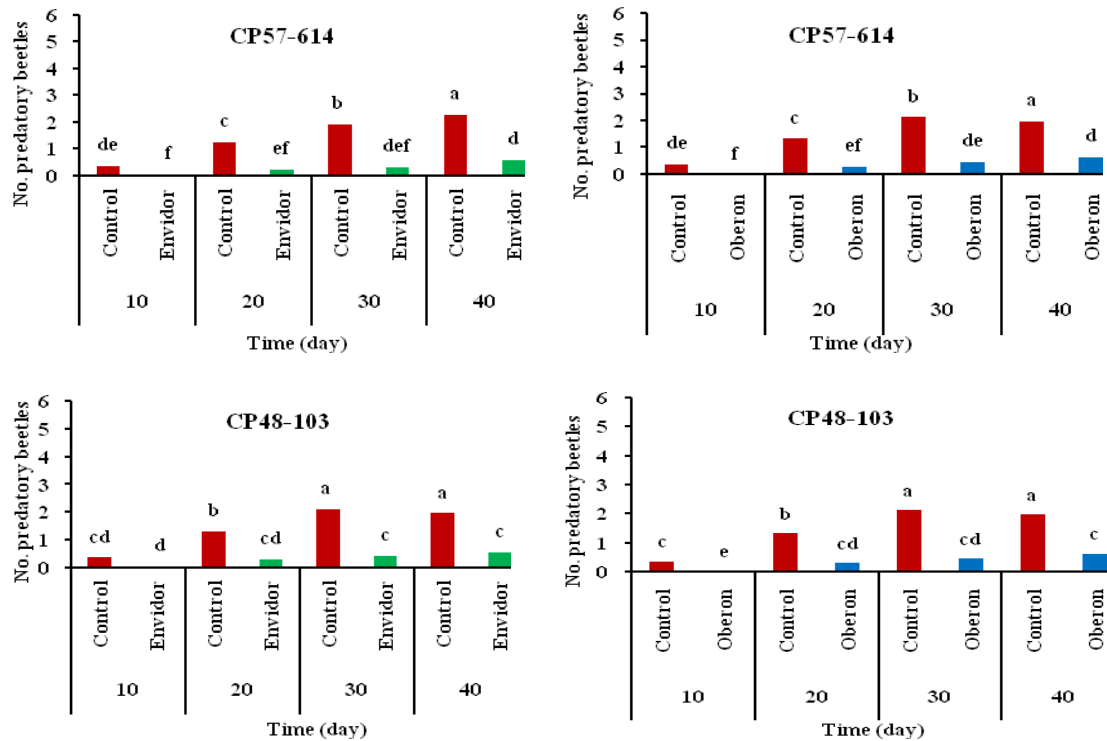

Fig. 2. Number of predatory beetles exposed to Envidor[®] and Oberon[®] acaricides
Means followed by the same letters are not significantly different at $P < 0.05$.

DISCUSSION

One of the most reliable strategies for controlling mite populations in sugarcane fields is selected spraying of acaricides in “hot spots” when the populations of mite are not high (Nikpay & Soleyman Nejadian, 2013; Singh *et al.*, 2003). However, the results of our trials indicated that application of Envidor[®] and Oberon[®] can reduce the mite populations on the two sugarcane cultivars, as proportionately lower mite populations were encountered on treated cultivars as compared to control plots. In 2003, Singh *et al.*, applied seven acaricidal treatments on variety CoS 767, and concluded that among treatments, Lime-Sulphur and Nethrin (1.25 Lit/ha) gave significant and maximal reduction in the frequency of *O. sacchari* infestation and enhancing cane yield. In the cultivar CP57-614, there are significant differences between both Envidor[®] and Oberon[®] in different time duration after acaricides application.

The same results obtained in CP48-103 cultivar. After 30 days of application, we saw a reduction in the efficacy of both acaricides and it seems this phenomenon is related to high temperature during growing season of sugarcane, and these acaricides degraded after 30 days of application. Under field conditions, however, acaricides and other pesticides are known to be affected by weather conditions (Wraight & Ramos, 2002). In past trials with Neem-Azal, Nikpay *et al.* (2012) found that only after 15 days the Neem-Azal lost its effectiveness against *O. sacchari* and we could not obtain any significant differences between Neem-Azal treatment and control after 15 and 30 days. Envidor[®] and Oberon[®] have a broad-spectrum action against sugarcane yellow mite *O. sacchari* and expected to affect beneficial coccinellid beetles (*S. gilvifrons*). In our trial, in both cultivars, a significant reduction of predatory beetles were occurred and indicated that both acaricides have negative effects on biological control agents. It could be concluded that the application of Envidor[®] and Oberon[®] may protect sugarcane against mites and have some negative effects on coccinellid beetles. However, integrating acaricides with other reduced-risk methods such as cultural and biological control could be applied in an IPM program strategy in sugar industry.

ACKNOWLEDGMENTS

We are grateful to Bayer Crop Science (Tehran office) for kindly providing the samples for experimentations. We are thankful to staff of plant protection department and the managing director of Salman Farsi Agro-Industry for technical support and providing fields for experiments.

REFERENCES

- Afshari, GA 1999, ‘A survey on the ladybirds belonging to the genus *Stethorus* and study of the biology, prey consumption and population dynamics of *Stethorus gilvifrons* in sugarcane farms in Khuzestan, Iran’, Master Science Thesis, Shahid Chamran University, Ahvaz, Iran.
- Biddinger, DJ, Weber, DC, & Hull, LA 2009, ‘Coccinellidae as predators of mites: Stethorini in biological control’, *Biological Control*, vol. 51, no., pp. 268-283.
- James, G 2004, ‘*Sugarcane*’: Blackwell Publishing.

- Laycock, DS 2004, '*Manual for field trials in plant protection*', (4 th ed.). Switzerland: Syngenta Agro.
- Leslie, G 2004, 'Pests of sugarcane', In G James (Ed.), *Sugarcane* (2nd ed., pp. 78–100). Oxford: Blackwell Science.
- Nikpay, A, Arbabi, M, & Kahrarian, M 2011, '*Evaluation new acaricides in control of sugarcane yellow mite *Oligonychus sacchari* and effect on *Stethorus punctillum* in south western part of Iran*', Paper presented at the Global Conference on Entomology, Chiang Mai, Thailand.
- Nikpay, A, Arbabi, M, & Kahrarian, M 2012, '*Potential application of Neem-Azal against spider mite *Oligonychus sacchari* on two sugarcane commercial cultivars*', Paper presented at the 6th World Neem Conference, Nagpur, India.
- Nikpay, A, & Soleyman Nejadian, E 2013, '*Field applications of silicon-based fertilizers against sugarcane yellow mite *Oligonychus sacchari* on four sugarcane cultivars*', Paper presented at the Proceedings of 28th International Society of Sugarcane Technologists, Sao Paulo, Brazil.
- Singh, M, Jadaun, VC, Singh, SR, Singh, A, Lal, K, & Singh, SB 2003, 'Chemical control of sugarcane yellow mite *Oligonychus sacchari*', *Sugar Tech*, vol. 5, no., pp. 77-78.
- Wraight, SP, & Ramos, ME 2002, 'Application parameters affecting field efficacy of *Beauveria bassiana* foliar treatments against Colorado Potato Beetle *Leptinotarsa decemlineata*', *Biological Control*, vol. 23, no. 2, pp. 164-178.

IMPLEMENTATION OF MINERAL OIL FOR CONTROLLING APHID AND WHITE RUST DISEASE OF CHRYSANTHEMUM

Mofit Eko Poerwanto* & Ari Wijayani

Faculty of Agriculture, Universitas Pembangunan Nasional "Veteran" Yogyakarta

Yogyakarta, Indonesia

* Corresponding author: mofit.eko@upnyk.ac.id

ABSTRACT

The main constraints that determine chrysanthemum flower quality are white rust disease and aphid as pest and vector of viral diseases. Preliminary study on oil application was conducted farmer plastic house in Wonokerso, Sleman, Yogyakarta. Five blocks of chrysanthemum plants, as replicates. Each block comprised of four plots as oil treatments: 0.125%, 0.250%, 0.500% v/v of horticultural mineral oil (HMO), and 0% or water. Application was conducted fortnightly, started from eight weeks after planting up to harvested (three months). Oil application could not prevent the increase of population. There was no significant difference between oil concentration treatments. However, oil in concentrations of 0.250% and 0.500% were able to decrease the spread of white rust, with the disease severity of 69.44% and 65.00% respectively after the third application. Higher concentration or frequency was required to achieve significant control on aphid population.

Keywords: chrysanthemum, white rust, mineral oil, vector,

INTRODUCTION

Chrysanthemum is one of favourite cut flowers, especially for the middle class and above. Quality of chrysanthemums and other cut flowers is the main factor that determines consumer preferences. The main constraints that determine its quality is white rust disease and aphid. Chrysanthemum white rust (CWR) can be a serious disease of chrysanthemum crops. According to Kristina *et al.* (1994), white rust disease (*Puccinia horiana* P. Henn.) may decrease freshness of chrysanthemum flowers (vase - life) into only 5 days, significantly shorter than the healthy ones. It freshness can last up to 12 days at room temperatures (27-29°C). Chrysanthemum yield loss caused by white rust disease is reaches 30% in Indonesia (Suhardi 2009a), 80% in Turkey (Gore 2007), and 100% in New England (Ellis 2007). Some insects reported as vector of some virus diseases, i.e. *Aphis craccivora*, *Acyrtosiphon pisum*, and *Myzus persicae* (Rahardjo *et al.*, 2005) *Macrosiphoniella sanborni*, *Rophalosiphum sp.* (Aphididae) (Djatnika *et al.*, 1994; Balithi, 2007) also attack leaves of chrysanthemum.

Various pest and disease control measures has been done, such as the use of tolerant varieties, culture technique (i.e. cutting infected leaves and setting watering), the use of natural enemies, and the application of synthetic pesticides. However, the intensity of pest and disease still high. There has been a resurgence in interest in horticultural

mineral oil in the past decade for a variety of agricultural uses (Beattie *et al.*, 2002). Its pesticidal effects cover a broad range of arthropod pests and include acute mortality, repellency, and oviposition deterrence (Zwick and Westigard, 1978; Davidson *et al.*, 1991; Fernandez *et al.*, 2001). Recent investigations have elucidated the mode of action against plant diseases (Northover & Schneider, 1996), and oils have shown promise against mildew diseases of grape, cherry, and apple (Northover and Schneider, 1996; Grove, 1999; Grove and Boal, 2002). Recently, mineral oils were found to be highly effective against citrus pest (Rae *et al.* 1996; Cen *et al.* 2002). Horticultural mineral oil (HMO) is highly refined mineral oils originated from crude petroleum oils. It is paraffinic compound ($\geq 60\%$ of carbon atoms occur in chains). It has unsulfonated residue (UR) values $\geq 92\%$ (therefore it contains $\leq 8\%$ aromatic molecules). Its molecule weights vary and is reflected in the number of carbon atoms. The lightest oils are nC21 oils, and the heaviest oils are generally nC25 oils. These values reflect the median equivalent n-paraffin carbon numbers and distillation temperatures (Agnello 2002; Beattie 2005). Several factors favor the use of horticultural mineral oil, including low cost, low mammalian toxicity, and few deleterious environmental effects (Fernandez *et al.*, 2005).

MATERIALS AND METHOD

Preliminary research was conducted in farmer plastic house in Wonokerso, Sleman, Yogyakarta. Five blocks of chrysanthemum plants, as replicates, were set in the plastic house. Each block divided into four plots as treatments. Each plot consisted of 25 plants. The treatments were 0.125%, 0.250%, 0.500% v/v of horticultural mineral oil (HMO: nC21 Sunspray Ultra Fine[®], Amtrade Pty), and 0% or water. They were set randomly in each block. The oil spray was applied evenly to foliage to the point of initial run-off. The upper and lower side of leaves, twigs and branches were sprayed thoroughly. Application was conducted fortnightly, started from eight weeks after planting up to harvested (three months). Agitation of oil was started when the oil was added to water and was maintained during spraying. The plants were irrigated every two days, and fertilized with N, P, and K with the dose of 75, 75, and 25 gram/plant respectively.

Assessment was conducted on aphid population and the spread of white rust disease. Aphid population were assessed fortnightly before oil spray application on nine randomly chosen central plants within each plot. Visual observations determined the number of aphid per leaf on five chosen leaves on upper part of tree. The spread of white rust was assessed at same samples as aphid assessment by recording fortnightly the number of leaves infected based on the rating scale of severity (Table 1.)

Table 1. Disease severity rating scale used to access the spread of white rust

Severity rating	Description
0	Leaf without any symptom
1	< 25% part of leaf showing symptom
2	25% up to < 50% part of leaf showing symptom
3	50% up to < 75% part of leaf showing symptom
4	$\geq 75\%$ part of leaf showing symptom

Data were subjected to one-way ANOVA (analysis of variance). Duncan's multiple range test (DMRT) was used to determine the differences among treatments when the ANOVA was significant (Gomez and Gomez, 1983). Significance different was arise at $P < 0.05$. Analysis was performed using SPSS® version: 10.0.5 (SPSS, 1999).

RESULTS AND DISCUSSION

The aphid population did not develop rapidly, even though the population keeps rising with or without the application of oil (Figure 1.). It may due to humid condition of the plastic house. Oil application could not prevent the increase of population. There was no significant difference between oil concentration treatments (Table 2.). It seemed that oil film could not provide a barrier by masking the feeding and oviposition stimulants, hence preventing the aphid from locating, accepting or using the host plant. It was not consistent with the report on the adult females of two spotted mite (*Tetranychus urticae* Koch [Acari: Tetranychidae]) (Liu & Beattie 2002), Asiatic citrus psylla (*D. citri* Kuwayama) (Rae *et al.* 1997), whiteflies (*Bemesia argentifolii* Bellows and Perring [Hemiptera: Aleyrodidae]) (Stansly *et al.* 2002), greenhouse thrips (*Heliethrips haemorrhoidalis* Bouche [Thysanoptera: Thripidae]) (Liu *et al.* 2002). They do not lay their eggs on plant treated with oils. Density of damage spots caused by citrus red mite (*Panonychus citri* McGregor [Acari: Tetranychidae]) feeding activity was reduced significantly on plant treated with these oils (Cen *et al.* 2002). Greenhouse thrips preferred untreated fruit to HMO-treated fruit as feeding site (Liu *et al.* 2002).

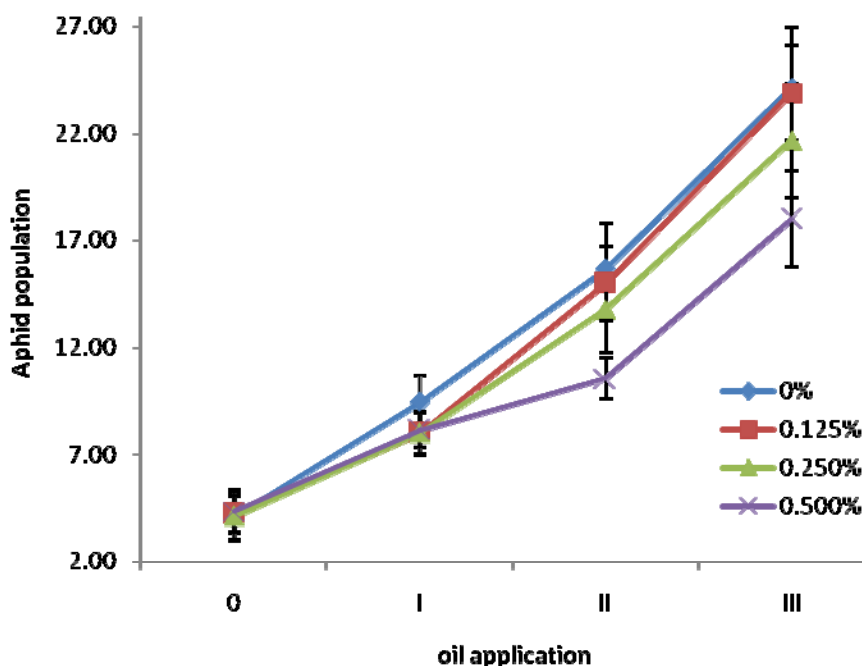

Figure 1. Aphid population (Mean \pm SE) on chrysanthemum leaf treated with 0%, 0.125%, 0.250%, and 0.500% v/v oil application

Disease severity of white rust on chrysanthemum leaves was quite high. It increased rapidly on the control (0% oil) and on the 0.125% oil application with the severity of 43.89% and 45.00% into 88.89% and 86.67% respectively (Figure 2.). Oil application in

concentrations of 0.250% and 0.500% were able to decrease the spread of white rust, with the severity of 69.44% and 65.00% respectively (Table 2.). Oil might be caused deformation of appressoria and affected on uredospores germination to infect chrysanthemum plants. Similar result has been reported by Sallam *et al.*, (2001) on wheat rust (*Puccinia recondite* f. sp. *Tritici.*). Oils could also provide a mechanical barrier to prevent the invasion of uredospores germ tube (Tawfik *et al.*, 2001). The success of oil in suppressing plant disease was also achieved on powdery mildew (Fernandez *et al.*, 2006).

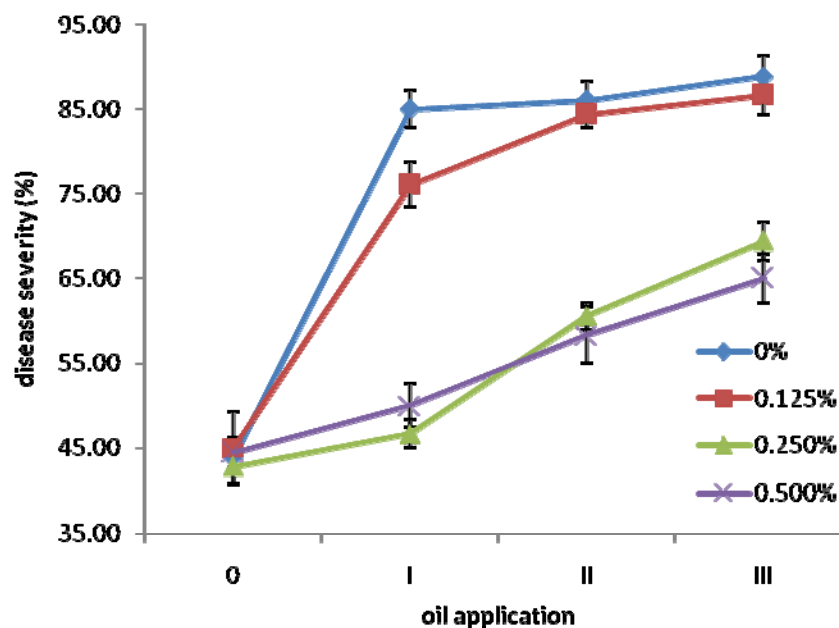

Figure 2. Disease severity (Mean ± SE) of white rust on chrysanthemum leaf treated with 0%, 0.125%, 0.250%, and 0.500% v/v oil application

Table 2. Aphid population and disease severity of white rust (Mean ± SE) on chrysanthemum leaf after third application of 0%, 0.125%, 0.250%, and 0.500% v/v oil

Oil concentration (% v/v)	Aphid population	Disease severity (%)
0	24.11 ± 2.86 q	88.89 ± 2.47 a
0.125	23.89 ± 2.20 q	86.67 ± 2.36 a
0.250	21.67 ± 2.66 q	69.44 ± 2.27 b
0.500	18.00 ± 2.25 q	65.00 ± 2.89 b
Probability (P)	0.298	< 0.001

Numbers in columns followed by the same letter are not significantly different

Significant suppression of aphid would likely require either higher concentration of oil or more frequent application of oil than were used in this study to form appropriate oil layer density on leaves surfaces. The level of suppression related to the number of

applications (Fernandez *et al.*, 2006). It should be thick enough to prevent the emitting of leaves volatile.

CONCLUSION

Oil application on concentration of 0.250% and 0.500% was able to suppress the severity of white rust on chrysanthemum. Higher concentration or frequency was required to achieve significant control on aphid population.

REFERENCES

- Agnello AM. 2002. Petroleum-derived spray oils: chemistry, history, refining and formulation. In: Beattie GAC, Watson DM, Stevens ML, Rae and Spooner-Hart editors. *Spray oils beyond 2000 sustainable pest and disease management*, pp.2-18.
- Balithi. 2007. Warta penelitian dan Pengembangan Pertanian 29(6): 16-17.
- Beattie GAC, Watson DM, Stevens ML, Rae DJ, Spooner-Hart. (2002) *Spray Oils Beyond 2000*. Sydney: University of Western Sydney.
- Beattie GAC., Hardy S. 2005. Using petroleum-based spray oils in citrus. *Agfact H2.AE.5*. 7 p
- Cen YJ, Tian MY, Pang XF, Rae DJ. 2002. Repellency, antifeeding effect and toxicity of a horticultural mineral oil against citrus red mite. In: Beattie GAC, Watson DM, Stevens ML, Rae and Spooner-Hart (eds). *Spray oils beyond 2000 sustainable pest and disease management*, pp. 134-141.
- Fernandez, DE., Beers, EH., Bruner, JF., Doerr, MD., Dunley, JE. 2006. Horticultural mineral oil applications for apple powdery mildew and codling moth, *Cydia pomonella* (L.). *Crop Protection* 25: 585-591.
- Liu ZM, Beattie GAC. 2002. Effect of a horticultural mineral oil on oviposition by two spotted mite *Tetranychus urticae* Koch (Acari: Tetranychidae). *General Application of Entomology*. 31: 65-67
- Liu ZM., Beattie GAC, Johnson D, Spooner-Hart R. 2002. Feeding and oviposition responses of greenhouse thrips to horticultural mineral oil deposits on Valencia orange fruit and mango leaves. In: Beattie GAC, Watson DM, Stevens ML, Rae and Spooner-Hart (eds). *Spray oils beyond 2000 sustainable pest and disease management*, pp. 147-151.
- Rae Dj, Liang WG, Watson DM, Beattie GAC, Huang MD. 1997. Evaluation of petroleum spray oils for control of the Asian citrus psylla, *Diaphorina citri* Kuwayama (Hemiptera: Psyllidae) in China. *International Journal of Pest Management*. 43: 71-75.
- Rae Dj, Liang WG, Watson DM, Tan BL, Li M, Ding Y, Xiong JJ, Du DP, Tang J, Beattie GAC, Huang MD. 1996. Comparison of petroleum spray oils, abamectin, cartap and methomyl for citrus leafminer control in southern China. *Journal of Economic Entomology*, 89: 493-500.

- Rahardjo IB, Muharam A, & Sulya Y. 2005. Studi pembuatan anti serum poliklonal untuk deteksi cepat virus mozaik mentimun pada krisan. *J Hortikultura* 15 (2):124-128.
- Sallam, MEA., Mona, MA., Taleb, A., El-Nashar, FK. 2001. Evaluation of some plant and mineral oils on the control leaf rust disease of wheat. *J. Phytopathol.* 29: 1-17.
- SPSS Inc. 1999. SPSS® for Windows™ Version 10.0.5. Chicago: SPSS Inc.
- Stansly PA, Liu TX, Schuster DJ. 2002. Effects of horticultural mineral oils on a polyphagous whitefly, its plant hosts and its natural enemies. In: Beattie GAC, Watson DM, Stevens ML, Rae and Spooner-Hart editors. *Spray oils beyond 2000 sustainable pest and disease management*, pp. 120-133.
- Tawfik, AE., Hanna, AI., El-Ghareeb, LA., Gomah, AA., Mahmoud, SM. 2001. Applied approach for controlling brown rot and soft rot bacteria of potatoes. *J. Agric. Sci.* 26: 3631-3642.

THE ROLE OF WEEDS IN THE SPREAD OF VECTOR OF PEANUT STRIPE VIRUS (PSTV)

Mofid Eko Purwanto and Siwi Hardiastuti

^{1,2}Department of Agrotechnology, Faculty of Agriculture, Universitas Pembangunan Nasional "Veteran" Yogyakarta, Indonesia

Email: mofit.eko@upnyk.ac.id

ABSTRACT

Peanut stripe virus (PStV) is the most serious disease in peanut production in the world. It is mainly vectored by *Aphis* spp. Intensive application of insecticides is ineffective and also costly. Various weeds species in peanut plantation areas are suggested to be alternative hosts of the vectors. Research on the preference of *Aphis cracivora* on the various weeds is needed for completing an integrated PStV disease management program. Five dominant weeds identified from vegetation analysis were arranged randomly in circular fashion inside the nylon mesh cage, and 50 *A. cracivora* adults, which had previously been starved for 24 h, were released in the middle of the arena. The position and the number of *A. cracivora* were recorded after 24 h. Some weeds could take a role in spreading the vector of PStV, as alternative hosts. *Cyperus iria*, *Pertulaca oleraceae*, and *Boerhavia erecta* can be served as alternative hosts for aphids. Most of *A. cracivora* stayed for feeding on *C. iria* (71.20%) and were able to multiply their population up to ~350 individuals in 17 days. It was significantly different to *Pertulaca oleraceae* (22.00%), and also to *Boerhavia erecta* (6.80%), *Digitaria longiflora* (0.00%), and *Oxallis barrelieri* (0.00%).

Keywords: Preference, Alternative host, *Aphis cracivora*, Disease management

INTRODUCTION

Peanut production in Indonesia in 2009 was 777,888 tons, with the area of 622,616 Ha (BPPS, 2011). The productivity was 1.249 ton/Ha, much lower than the potential yield (2.5 ton/Ha). One of the obstacles was the peanut stripe disease caused by peanut stripe virus (PStV). Peanut stripe disease is the most serious disease in Indonesia. Yield loss due to stripe disease ranges from 10 to 60% depending on the varieties of peanuts, season and plant age at infection (Saleh and Baliadi, 1992; Obopile, 2006). This disease is also widespread in Malaysia, Philippines, Thailand, Vietnam, Korea, Japan and United States (Demski et al., 1993).

Spread of the virus in the field is mainly vectored by *Aphis craccivora*, although mechanical and seed transmission may also occur. It is also vectored by *A. glysinis*, *A. porii*, *Rhopalosiphum maydis*, *R. rice*, *Trichosiphonaphis* sp., *Hysteroneura setariae* and *Mycus persicae* (Soeprapto, 1991). Given its role as an insect vector, the basic strategy in PStV management is the vector control. Various weeds in peanut areas could serve as alternative hosts of the vector that escaped from PStV vector control efforts. In

order to complement an integrated program of peanut stripe disease management, the assessment of the weeds role in the spread of insect vectors of PSTV is required.

MATERIALS AND METHODS

A. *cracivora* culture

Aphids were maintained on the shoots of peanuts, planted in pots covered by nylon mesh cages (1 m long, 1 m wide, and 1 m high).

1. Vegetation analysis of weeds in peanut areas

Vegetation analysis was conducted on five peanut areas to determine the dominant weeds. Ten samples per area, totally 50 samples, were gained by throwing ring samples (1 m x 1 m) randomly on the peanut areas.

2. The preference of *A. cracivora* on various weeds

Choice tests and no-choice test were performed on five most dominant weeds. Choice test was conducted by planting five most dominant weeds in small pots (Ø 50 mm, high 80 mm), covered by cylindrical nylon mesh cage (Ø 600 mm, height 300 mm) and arranged randomly in circular fashion. Fifty *A. cracivora* adults, which had previously been starved for 24 h, were released in the middle of the arena. The number and position of aphids on each of the weed were recorded after 24 h. No-choice test was conducted by using the five most dominant weeds planted in pots as used in the choice test. Each weed was covered with cylindrical nylon mesh cage (Ø 100 mm, height 300 mm) and 50 aphids which had previously been starved for 24 hours, were released on the buds of each weed. The number of aphids was recorded every 48 h. Analysis of variance was performed by using SPSS 10.0.5 (SPSS, 1999), and the level of significance was set at $P < 0.05$.

RESULTS AND DISCUSSION

The vegetation analysis of 19 species of weeds found at peanut areas is presented in Table 1. Based on the vegetation analysis results, the five most dominant weeds were chosen for choice and non-choice tests. *Digitaria longiflora* (grass group) was the most dominant weed in peanut areas followed by *Boerhavia erecta*, *Pertulaca oleraceae*, and *Oxallis barrelieri* (broadleaf groups), *Cyperus iria* (sedge group) with the Summed Dominance Ratio (SDR) value of 15.09%, 8.69%, 10.51%, 8.96%, and 11.38%, respectively.

All aphids fed on the leaves of some tested weeds in the choice test (Figure 1). The most preferred weed was *Cyperus iria*. The average percentage of aphids feeding was 71.20%, significantly different from *Pertulaca oleraceae* (22.00%), *Boerhavia erecta* (6.80%), while *Digitaria longiflora* and *Oxallis barrelieri* were not chosen by aphids for feeding. These differences may be caused by nutritional similarity of the weed and aphids' host plant (peanuts) or by the presence of certain substances that were attracting

aphids to feed. The substances could be various alcohol and aldehyde compounds in the leaves that were specific and volatile. Those were used by aphids for finding their host plants (Visser, 1986, Petterson et al., 1998). Similar results were obtained on Gemini virus vector *Bemecia tabaci* (Sudiono and Purnomo, 2008) and also on spreading Peanut Stripe Virus (PStV) (Hardiastono, 2001). *B. tabaci* was able to live on the broadleaf weed *Ageratum conyzoides*. Weeds could also serve as a source of gemini virus inoculum. While the weeds *Amaranthus spinosus*, *Bidens pilosa*, *Crotalaria incana*, and *Physalis angulata* were able to be potential alternative hosts and sources of PStV inoculum.

Aphids were able to multiply rapidly in *C. iria* (Figure 2.) in a choice test. The average population was 347.60 on day 17, significantly different from *P. oleraceae* (63.20), *B. erecta* (45.80), *D. longiflora* (0.00) and *O. barrelieri* (0.00) (Table 2.). The ability to increase their population on non host plants indicated the existence of the nutrients contained in weeds that resemble their host plant nutrition. The population began to decline on *C. iria* after day 17 due to the limited ability of weeds to sustain the aphids' population. However, population on *P. oleraceae*, *B. erecta* was still rising despite lower than *C. iria* (Figure 2.). The abundant population led to aphids' migration from weeds into the main host plant (peanut).

Table 1. Vegetation analysis of weeds at peanut plantation areas (n: 50)

No	Weeds species	SDR (%)
1	<i>Cleome ruidosprema</i>	2.38
2	<i>Digitaria longiflora</i>	*15.09
3	<i>Eleusin indica</i>	4.29
4	<i>Hibanthus attenuatus</i>	6.17
5	<i>Hedvontis carimbasa</i>	7.30
6	<i>Boerhavia erecta</i>	*8.69
7	<i>Ageratum conyzoides</i>	3.87
8	<i>Pertulaca oleraceae</i>	*10.52
9	<i>Euphorbia hirta</i>	1.53
10	<i>Spegelia antelmia</i>	1.73
11	<i>Synedrella nodiflora</i>	6.42
12	<i>Oxallis barrelieri</i>	*8.96
13	<i>Imperata cylendrica</i>	2.28
14	<i>Cyperus iria</i>	*11.38
15	<i>Dactyloctenium aegyptim</i>	2.02
16	<i>Ipomea triloba</i>	2.12
17	<i>Phylanthus neruri</i>	1.73
18	<i>Tridax procumbent</i>	1.75
19	<i>Euphorbia prunifolia</i>	1.73
Total		99.96

* Five most dominant weeds for choice and non-choice test

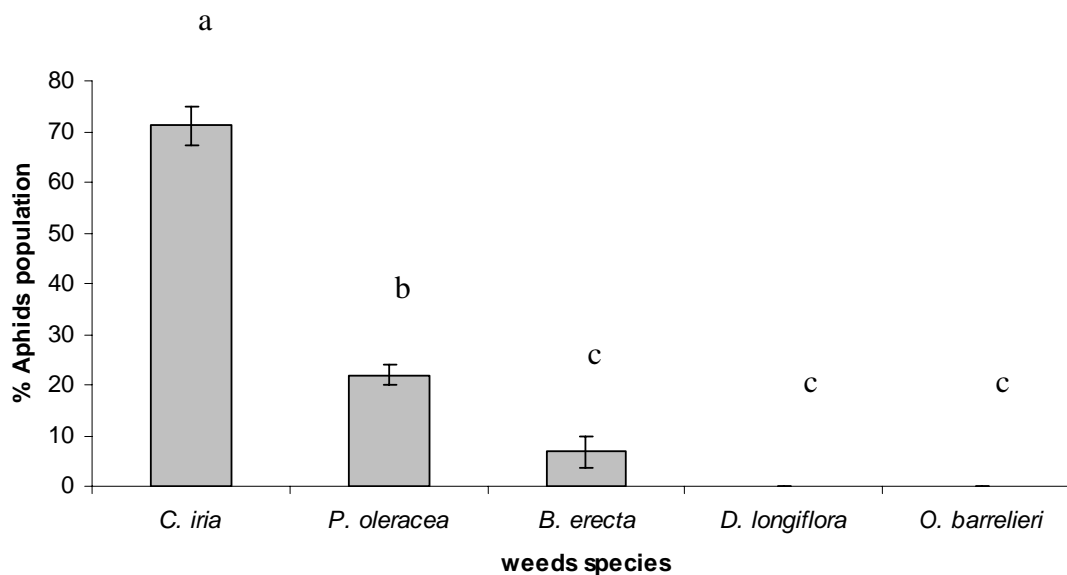

Figure 1. The preference of *A. cracivora* in various weeds of peanut conducted in choice mode with initial population 50, recorded after 24 h. Bars followed by the same letter are not significantly different ($P < 0,001$). n: 10

All aphids on *P. oleraceae*, and *B. erecta* were not able to feed on weeds but stayed on the cages. This behaviour indicated that aphids were not able to recognize those two species of weeds as alternative host plants that can be used as food source. While the slow-growing population of aphids on *P. oleraceae* and *B. erecta* was probably due to the amount of water contained in the weeds that were structurally very different from its host plants (peanuts). The high water content also caused low content of volatile compounds, and was unable to attract aphids to feed and breed on those weeds (Table 2.).

The implications of preferences and breeding ability of aphids on species of weeds are the presence of alternative hosts for aphids when peanut plants are not available, either because there are no peanut plants or when the plants are treated with pesticides. The presence of alternative hosts would cause the population of aphids to be available throughout the season and to serve as the initial population for the next generation. The role of aphids as vectors of PStV will also make disease inoculum to be always available in the field throughout each season. This will further complicate the control measures against the disease on peanut plants, because the transmission of disease by insect vectors of disease, especially PStV is highly dependent on the availability of disease inoculums and insect vectors in the field (Chen, 1998, Zeyang et al., 1996, Soleh, 2003).

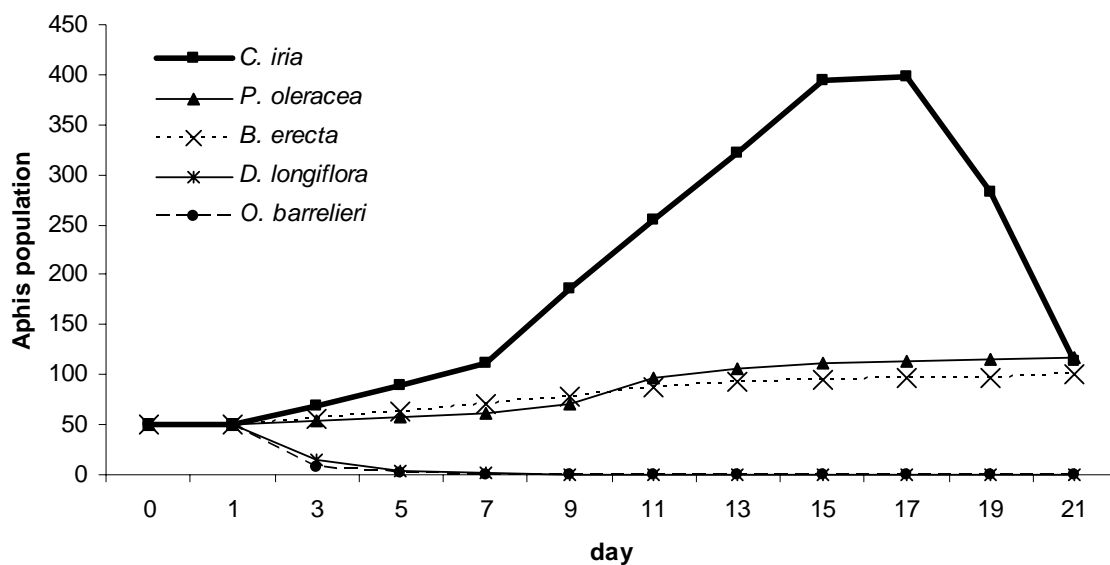

Figure 2. Population dynamic of *A. cracivora* per plant of various weeds species for 21 days. (n: 10)

Table 2. Average population of *A. cracivora* in various weeds species in day 17 (n: 10)

No.	Weeds species	Population in day 17
1	<i>Cyperus iria</i>	347,60 a
2	<i>Pertulaca oleraceae</i>	63,20 b
3	<i>Boerhavia erecta</i>	45,80 b
4	<i>Digitaria longiflora</i>	0,00 c
5	<i>Oxallis barrelieri</i>	0,00 c

Numbers followed by the same letter are not significantly different ($P < 0,001$)

CONCLUSION

C. iria, *P. oleraceae*, and *B. erecta* can be served as alternative hosts for aphids, vector of PSTV, with *C. iria* as the most preferred alternative host

ACKNOWLEDGMENT

We gratefully acknowledge the LPPM-UPN "Veteran" Yogyakarta for financial support

REFERENCES

- BPS. 2011. Harvested area, productivity and production of peanuts in Indonesia. http://www.bps.go.id/tab_sub/view.php?tabel=1&daftar=1&id_subyek=53&no_tab=19. Accessed April 1, 2011. (bahasa Indonesia)
- Chen CN. 1998. Ecology of the insect vectors of citrus systemic diseases and their control in Taiwan. Food & fertilizer technology center. www.agnet.org/library/data/eb/eb459a/eb459a.pdf. Accessed April 1, 2011
- Demski, JW., Reddy, DVR., Wongkeiw, S., Xu, ZY., Casidy, BG., Shukla, DD., Saleh, N., Middleton, KJ. 1993. Peanut stripe virus. ICRISAT information bulletin. 38: 16 p
- Hardiastono, T. 2001. The potency of broad-leaved weeds as an alternative host of peanut stripe virus (PStV) in cultivation of peanut (*Arachis hypogaea* L.). Habitat. 12 (3): 139-146 (bahasa Indonesia)
- Obopile, M. 2006. Economic threshold and injury levels for control of cowpea aphid, *Aphis cracivora*, on cowpea. African plant protection 12: 111-115
- Petterson, J., Karunaratne, S., Ahmed, E., kumar, V. 1998. The cowpea aphid *Aphis cracivora*, host plant odors and pheromones. Entomological Experiment and Application 88: 177-184
- Saleh, N., Baliadi, Y. 1992. Peanut stripe virus disease and its control efforts. Crops Research Institute monograph Malang. no.8. 22 pp. (bahasa Indonesia)
- Soeprapto, A. 1991. Testing of peanut mottle virus transmission by the vector Aphis and through seed nuts. Thesis. 34 p. (bahasa Indonesia)
- Soleh, N. 2003. Ecobiology and optimization of disease control on peanut mottle virus through integrated crop management. Jurnal Litbang Pertanian 22(2):41-48 (bahasa Indonesia)
- SPSS Inc. 1999. SPSS® for Windows™ Version 10.0.5. Chicago: SPSS Inc.
- Sudiono, Purnomo. 2008. Host range study of whitefly infestation in the vegetables center, Tanggamus highlands. Jurnal penelitian pertanian terapan. 8:103-108. (bahasa Indonesia)
- Visser, JH. 1986. Host odor perception in herbivores insects. Annual Reviews of Entomology. 31, 121-144
- Zeyang, X., Zongyi, Z., Kunrong, K., Jinxang, C., Reddy, DVR. 1996. Curent research on groundnut virus disease in china. Proceeding on groundnut virus disease in the Asia Pasific region. ICRISAT. p:26

IN VITRO AND IN VIVO DIGESTIBILITY EVALUATION OF BACILLUS PHYTASES IN PLANT INGREDIENTS AND DIETS BY TILAPIA *Oreochromis mossambicus*

Rande B. Dechavez^{1,2} and Augusto E. Serrano, Jr.²

¹College of Fisheries, Sultan Kudarat State University, Kalamansig,
Sultan Kudarat, Philippines

²Institute of Aquaculture, College of Fisheries and Ocean Sciences,
University of the Philippines Visayas, Miagao, Iloilo, Philippines

Email: ran_dechavez@yahoo.com

ABSTRACT

Phytases are phosphohydrolases that catalyze the release of phosphate from phytate (myo-inositol hexakisphosphate), the major phosphorus (P) form mostly occurring in animal feeds of plant origin. These enzymes can be supplemented in animal diets to reduce inorganic phosphorus supplementation and fecal phosphorus excretion. Four species of *Bacillus* namely, *B. pumilus*, *B. megaterium*, *B. coagulans*, and *B. licheniformis* were used to study the biochemical characteristics of their phytases. All the strains investigated were able to hydrolyze extracellular phytate. The activity of phytase increased markedly at the late stationary phase in all the species tested. Highest enzyme activity was found in phytase from *B. megaterium* after the 4th day of culture. The crude phytases from the different *Bacillus* strains were optimally active at pH values ranging 5.5 to 7.0 at 37 °C and retained their activity at temperatures up to 80 °C. The enzymes exhibited thermostability, retaining ~50 % activity at 70 °C and were fairly stable up to pH 10. These properties indicate that the *Bacillus* phytases appear to be suitable for animal feed supplementation in aquaculture to improve the bioavailability of phosphorus. However, phytase activities varied between bacterial sources as well as between feed ingredients. For the cassava leaf meal, Pi released was highest using *B. pumilus* and was not significantly different from those of *B. megaterium* and *B. licheniformis*. For the soybean meal, Pi release was in the decreasing order: *B. megaterium* > *B. pumilus* > *B. coagulans* > *B. licheniformis* phytase. For the corn meal, addition of *B. licheniformis* phytase to the reaction mixture resulted in significantly higher Pi release followed by *B. coagulans* phytase which was not significantly different from that of *B. megaterium* phytase which released the lowest Pi. Pi released by *B. pumilus* phytase from corn meal was not significantly different from the lowest Pi release of *B. megaterium* phytase. The apparent digestibility coefficient (ADC) values for the feed dry matter (DM) ranged from 86.3 to 88.3% and were not significantly different from each other ($P > 0.05$). It further concluded that enzymes from *Bacillus megaterium* and *Bacillus pumilus* were recommended in the formulation of plant-based diets for fishes due to their thermal stability and wide range of pH.

Keywords: *phytases, Bacillus sp., in vivo digestibility, in vitro dephosphorylation, tilapia.*

INTRODUCTION

Phytic acid (*myo*-inositol hexakisphosphate) is the major storage form of P present in seeds of higher plants, particularly in cereal grains, legumes and oil seed crops (Lei and Porres, 2003) and it typically represents approximately 75% - 80% of the total P found in nature (Reddy et al., 1982). It is also a storage form of *myo*-inositol, an important growth factor. Under normal physiological conditions, phytic acid has strong chelating potential in the gut of animals' complexing essential minerals such as Ca, Mg, Fe and Zn, subsequently decreasing their bioavailability (Nolan et al., 1987). It is an antinutritive component in plant-derived food that makes enzymatic hydrolysis of phytic acid desirable.

The antinutritive effect of phytic acid is problematic in the feeding of fish (Richardson et al., 1985) due to their short gastrointestinal tracts that hinders the use of plant-derived protein. Thus, supplemental P_i is added to their feed to meet their P requirement for growth. This could be solved by using supplemental phytase (Simell et al., 1989). In this light, phytase has become an important industrial enzyme and is the object of extensive research.

Phytase catalyzes the hydrolysis of phytic acid to inositol phosphates and free orthophosphoric acid. These enzymes are widespread in nature occurring in some animal tissues, microorganisms as well as in plants. Phytase-producing microorganisms comprise bacteria such as *Bacillus subtilis* (Power and Jagannathan, 1982) *Pseudomonas* sp. and *Psychrobacter* sp. (Lazado et al., 2010) and *Escherichia coli* (Greiner et al., 1993); yeast such as *Schwanniomyces castelli* (Segueilha et al., 1992); and fungi such as *Aspergillus ficcum* (Howson and Davis, 1983) and *Aspergillus terreus* (Yamada et al., 1968).

Cloning and characterization of phytases has been conducted from microbes (Greiner et al., 1993; Ullah, 1988), plants (Greiner and Larsoon-Alminger, 2001) and animals (Craxton et al., 1997). Animal and plant phytase researches have shown optimistic results but, microbial phytases have been shown to have the most potential for biotechnological applications, because they have the capacity to produce and secrete large quantities of enzymes combined with the desired temperature and pH activities and stability properties. In general, the phytase produced by fungi are extracellular, whereas the enzymes from bacteria are mostly cell-associated. The only bacteria showing extracellular phytase activity are those of the genera *Bacillus* (Shimizu, 1992; Kim et al., 1998) and *Enterobacter* (Yoon et al., 1996).

Based on a previous study, it has been demonstrated that bacteria of the genus *Bacillus* exhibit the best characteristics as enhancers of feeds; the most recent work has used *Bacillus subtilis* (Kerovou, 2000). It is then worthwhile to evaluate other species that could possibly produce phytases with the desired properties. However, any phytase preparation requires rigorous evaluation of its efficacy in hydrolyzing phytic acid. It is also hypothesized that supplementation of low nonphytate P diets with the new phytase improves phytate P digestibility and growth performance.

Therefore, different *Bacillus* species *Bacillus pumilus* Acc no. 1513, (2) *Bacillus megaterium* Acc no. 1643, (3) *Bacillus coagulans* Acc no. 1510 and (4) *Bacillus*

licheniformis Acc no.1035 were investigated in the present study for phytase activity and crude enzyme phytase to assess phytase activity in relation to temperature and pH *in vitro*. Also using actual plant ingredients and formulated plant - based diets with 2 mmol CaCl₂ as activators of the enzyme process to the growth of tilapia, *Oreochromis mossambicus* was studied.

MATERIALS AND METHODS

A. Screening of phytase production in *Bacillus* spp.

Various *Bacillus* species were used namely: *B. pumilus* (Acc. No. 1513), *B. coagulans* (Acc. No. 1510), *B. megaterium* (Acc. No. 1643) and *B. licheniformis* (Acc. No. 1035) acquired from the Philippine National Collection of Microorganism, University of the Philippines Los Baños, Laguna. Pure isolates of these bacterial strains were sub-cultured in the phytase screening medium described by Kerovuo (1998) and screened for phytase production. Strains that produce clear zones on the screening medium were tested for phytase production in a medium containing 10g L⁻¹ sodium phytate as a substitute for the Pi. Positive strains were inoculated in agar plates containing *Luria bertani* (LB) medium. Single colonies of the positive strains were re-inoculated in LB and incubated at 37⁰C and samples were withdrawn from the cultures at different time points up to 7 days. Following incubation, the cultures were centrifuged and the supernatant was assayed for phytase activity. Linearity of the activity with the amount of enzyme and with the reaction time was assessed to decide on the optimum assay conditions. The strain exhibiting the highest phytase specific activity was selected for quantitative production.

B. Assays on phytase activity

Phytase assays were routinely performed as described by Engelen et al.; (1994). Prior to assay, bacterial cultures were centrifuged at 4,000 rpm for 15 min at 0–4⁰ C. Briefly, 300µL culture supernatant and 600 µL substrate solution (5.1 mM sodium phytate) in 100 mM sodium acetate buffer (pH 6.0) containing 2 mM CaCl₂ (as an activator) were mixed and incubated in shaking water bath for 60 min at 37⁰ C. To stop the reaction, 900µL of 5% TCA (trichloroacetic acid) was added after 1 hour.. The release of P_i was measured spectrophotometrically at 700 nm by adding 300µL of color reagent (4 volumes of 1.5% ammonium molybdate in 5.5% sulfuric acid and 1 volume 2.7% ferrous sulfate) with distilled water as blank. One unit of phytase activity was defined as the amount of enzyme able to hydrolyze phytate to give 1 µmol of P_i min⁻¹ under the assay conditions. Specific activity was expressed as enzyme activity per mg protein. Protein concentration was determined using the modified Lowry method (Lowry et al., 1951) with bovine serum albumin as standard.

C. Optimization of assay

1. Optimum pH

The optimum pH for the activity of the crude enzymes was determined by carrying out standard assay described above using the following buffers (0.1M): Glycine–HCl (pH 2-

3); NaOAc–HOAc (pH 4 -7); Tris–HCl (pH 8); Glycine–NaOH (pH 9-11). The pH stabilities were examined by incubating the enzyme solution with these buffers at 25 °C for 1 h prior to performing the routine assay.

2. Optimum reaction temperature

The temperature profile of crude enzyme extracts were determined by performing the routine assay at different temperatures: 25, 35, 37, 40, 45, 50, 55, and 60 °C to determine optimum temperature, the crude enzymes were incubated at various temperatures which ranged 25 – 80 °C for 1 h, cooled to 4 °C and assayed.

D. Release of Pi *in vitro*

This experiment involved an *in vitro* evaluation of the release of P in soybean meal, cassava leaf meal and corn meal using different *Bacillus* species.

Dried and pulverized cassava leaf and corn and soybean meal and the crude enzyme were allowed to react for a determined period after which free Pi was measured spectrophotometrically. The same assay was done using the standard substrate (sodium phytate) as positive control. The Pi and phytic acid content of the leaf and bean meal were evaluated before and after addition of enzyme.

E. Pi released from soybean and other plant ingredients

Soybean meal weighing 0.40 g was mixed with 20 ml 100 mM sodium acetate buffer pH 6.0 containing 2 mM CaCl₂ after which 600 µL of the solution was mixed with 300 µL enzyme (*Bacillus sp*) and incubated in shaking water bath for 1 h at 37°C. To stop the reaction, 900 µL 5% TCA was added. The supernatant was used for P analysis with the following protocol. (1) P calibration curve preparation: pre-dried (80 °C, 2 h) 4.35 g ammonium phosphate was dissolved into 1 L flask to make the P concentration 10mg ml⁻¹, and adjusted P concentration to 0.00, 0.04, 0.08, 0.12, 0.16, 0.20, 0.24, 0.28, 0.32, 0.36, 0.40 mg ml⁻¹. (2) P measurement, 0.5ml supernatant was mixed with 2.5ml MS solution (5.0g sodium molybdate in 500 ml deionized distilled water, 14 ml 98% H₂SO₄ adjusted to 1000 ml) and 0.25 ml Elon solution (3% sodium sulfite and 1% *p* – methylamino phenol sulfate), incubated at room temperature for at least 60 min (Yin et al., 2006), and then the released Pi was measured spectrophotometrically at 700 nm.

F. *In vivo* digestibility tests of formulated feeds containing *Bacillus spp.*

1. Experimental Diet

Five experimental diets were formulated using plant ingredients and into which bacterial phytase was incorporated; the diet without phytase was used as the control diet (Table 1). The feed that was formulated was nutritionally adequate for the sex reversed tilapia *Oreochromis mossambicus*. Chromic oxide was incorporated to the feed at 5g kg⁻¹ dry matter as inert marker to estimate digestibility. Formulation of the diet was done as described by the Feed Development Section (1994) SEAFDEC/AQD.

Table 1. Composition of plant-based test diets fed to sex reversed tilapia *Oreochromis mossambicus*.

Ingredient	Amount (g/100g diet)
Fish meal	15.00
Soybean meal	41.09
Corn meal	34.91
Cassava leaf meal	5.00
Cassava starch (binder)	(5.00)
Cod liver oil	2.00
Vitamins/ mineral mix	2.00
Bacterial phytase	500 FTU
Chromic oxide	0.50
Proximate composition*	(% dry matter)
Moisture	4.34
Crude protein	35.24
Crude fat	1.41
Crude fiber	2.76
Ash	0.33
Nitrogen Free Extract	60.26

The experiment was conducted in fifteen (15) 50-L rectangular aquaria. Fish were stocked at a density of ten fish each for the digestibility study. Each aquarium had a hose connected to an Erlenmeyer flask that served as an improvised feces collector. The aquaria were supplied with a recirculating freshwater system with a flow rate of 600 ml min⁻¹ and each aquarium was provided with sufficient aeration.

2. Digestibility trial and protocol

A total of 150 *O. mossambicus* (62.41 g ABW) were stocked with 10 fish tank⁻¹ in triplicate tanks that were assigned randomly to each test diet. Experimental diets were fed to the fish twice daily at 0900 and 1600 h to satiation for 2 weeks. Uneaten feed were carefully siphoned off after the last feeding in the afternoon. Following tank cleaning, collection of feces was done in the morning at 0700 h by siphoning the feces from the fecal collector. The collected feces were centrifuged at 2,000 rpm for 2 min and kept frozen at -20 °C until sufficient samples per treatment were obtained.

Diet samples stored were ground with mortar and pestle to attain a particle size of 1 mm and subjected to protein analysis. Ground diet and fecal samples were dried for 24 h at 110 °C, digested with a mixture of nitric and perchloric acid at 200 °C for 4 h, and analyzed for chromium oxide. (Furukawa and Tsukahara, 1966). P was determined according to the method by Lovell (1975) and Pearson (1977).

The apparent digestibility coefficient (ADC) was estimated using the following formula: $ADC = 100 - [(\%Cr_d / \%Cr_f) \times (\%N_f / \%N_d) \times 100]$

Where: %Cr_f - is the % Cr in dried feces, %Cr_d - is the % Cr in dried diet, %N_d - is the % nutrient in dried diet, and %N_f - is the % nutrient in dried feces.

Apparent digestibility (AD) of the feed was calculated using the following formula:

$$\text{AD feed (\%)} = \frac{(\text{DM feed ingested (g)} - \text{DM feces (g)})}{\text{DM feed ingested (g)}} \times 100$$

G. Statistical analysis

Differences between treatment means on the phytase activity of the different ingredients and apparent digestibility coefficient of feeds were analyzed using one-way analysis of variance (ANOVA) followed by Tukey's Post-hoc test for the comparison of significantly different means. Before doing the ANOVA, the data were tested for homogeneity of variance and normality of data. All statistical calculations were performed using a Statistical Package for Social Sciences (SPSS) version 16.0 windows software.

RESULTS AND DISCUSSION

A. Production of the enzyme

During the initial screening of the *Bacillus* spp for phytase production, we found that all the strains grew in the phytase screening medium; clear zones formed around the colonies. Visual examination of clearing did not allow for the estimation of phytase activity thus the colonies were re-inoculated in Luria broth supplemented with sodium phytate as the sole phosphate source. Low levels of phytate-degrading activity were detectable during the first 3 d of culture period in all the species tested, and the activity increased markedly after the cells reached the stationary phase or the 4th day of culture (Fig.1). Phytase activity was not significantly different from each other under the specified assay conditions. After reaching the peak on the 4th day of culture, phytase activity gradually dropped concomitant with a decrease in cell density in longer incubation period (5-7 days).

B. Optimization of assay

1. pH optimum and stability

Fig. 2 shows that the pH activity profile of all the *Bacillus* phytase displayed similar patterns of responses to varying pH. An increase in activity up to pH 6.0 and a gradual decline at succeeding pH levels were observed for the enzymes. These phytases exhibited broad pH optima, with the highest activities at slightly acidic (pH 6.0) to neutral pH range. At lower pHs (3.0-5.0), less than 50% of the activities at optimal pH were observed in *B. pumilus* and *B. coagulans* phytases. On the other hand, *B. licheniformis* and *B. megaterium* phytases exhibited relatively higher activities at acidic pH range retaining 40-90% of its maximum activity.

All the *Bacillus* phytases increased stability with increasing pH, peaking at pH 6.0, and dropping gradually (Fig.3). Maximal stabilities of the *Bacillus* phytases at pH 6.0 coincided with the observed optimum pH. *B. megaterium* phytase displayed a wider pH stability range retaining 50-90% of its maximum activity at either lower (3-5) or higher

(8-10) pH levels. At highly alkaline pH (11.0) a significant drop in phytate-degrading activities were observed in all species tested with *B. coagulans* exhibiting the lowest relative residual activity.

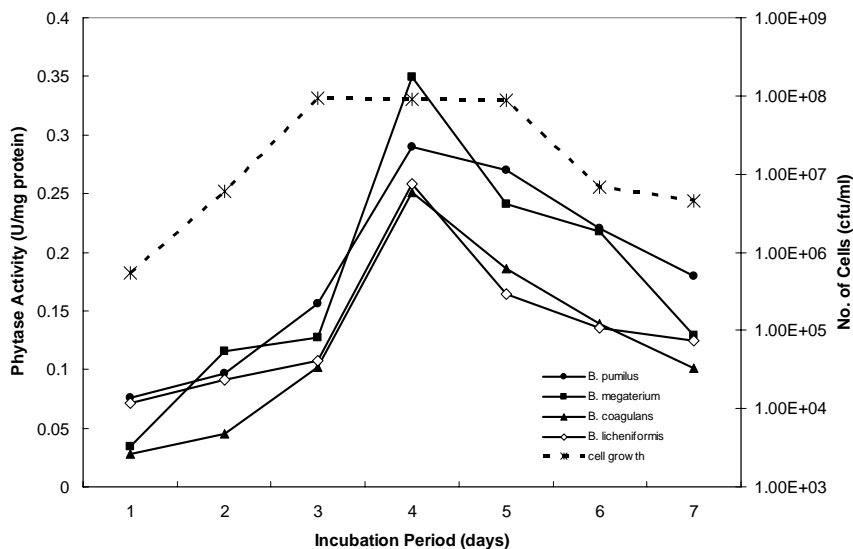

Fig. 1. Profile of phytase production and cell growth of the *Bacillus* spp. cultivated on LB medium containing sodium phytate at the different incubation period. (300 μ l enzyme + 600 μ l substrate sol'n + 2 mM CaCl_2 at pH 6.0 and 37 $^{\circ}$ C)

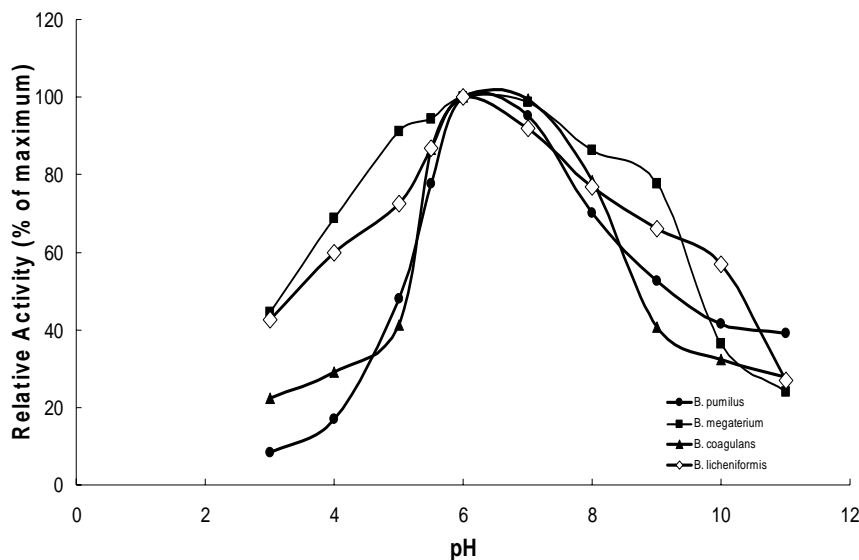

Fig. 2. Effect of pH on phytase activities of *Bacillus* spp. The enzyme activities were assayed at various pH buffers: Glycine-HCl (pH 2-3); NaOAc-HOAc (pH 4-7); Tris-HCl (pH 8); Glycine-NaOH (pH 9-11).

2. Optimum temperature and thermal stability

All the *Bacillus* spp phytases exhibited temperature optima at 35⁰C (Fig. 4). A sharp increase in activity was observed when the reaction temperature was increased from 25 to 35⁰C. A further increase in temperature however, caused gradual a decline. The *Bacillus* phytases exhibited good tolerance to high reaction temperatures retaining ~70% of the maximum activity at the highest temperature tested (80⁰C).

Thermal stabilities of the *Bacillus* phytases were maximal at 25⁰C (Fig.5). Immersing the phytase at temperatures higher than 25⁰C for 1 h resulted in activities that start to decrease with further temperature increments. *B. pumilus* and *B. megaterium* showed higher thermal stability retaining ~50% of the maximum activity with incubating temperatures up to 70⁰C. Enzyme activities decreased significantly at 80⁰C retaining only ~30% of the maximum.

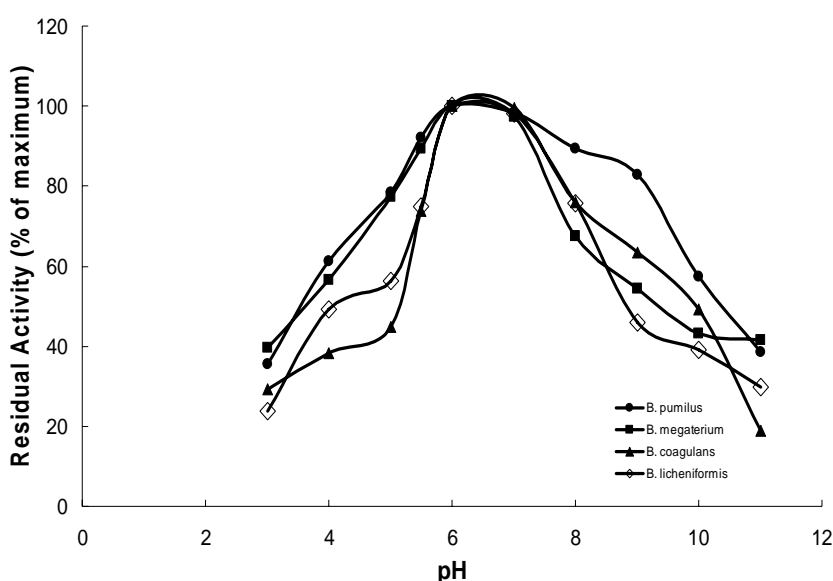

Fig. 3. Effect of pH on stability of *Bacillus* spp. phytases. The enzymes were incubated at various pH buffers: Glycine-HCl (pH 2-3); NaOAc-HOAc (pH 4-7); Tris-HCl (pH 8); Glycine-NaOH (pH 9-11) and the residual activities were measured.

C. P_i released in soybean meal and other plant ingredients

Results of the study on the amount of P_i released from various plant meals showed that the enzyme activity varies depending on the sources of bacterial phytase. Phytase from *B. licheniformis* displayed significantly the highest phytase activity among the phytases. The P_i released from cassava leaf meal (Fig. 6) showed that phytase from *B. pumilus* displayed the highest activity (961 mg kg⁻¹) followed by phytase from *P. megaterium* (862 mg kg⁻¹), phytase from *B. licheniformis* (852 mg kg⁻¹) while the lowest was phytase from *B. coagulans* (491mg kg⁻¹). Phytase activity of *B. coagulans* was significantly the lowest among the phytase activities. Fig. 7 shows that the highest amount of P_i released from soybean meal was 1,212 mg kg⁻¹ (phytase *B. megaterium*) and the lowest was 732 mg kg⁻¹ from phytase *B. licheniformis*. The P_i released by phytase *B. megaterium* was significantly different from that of *B. pumilus*,

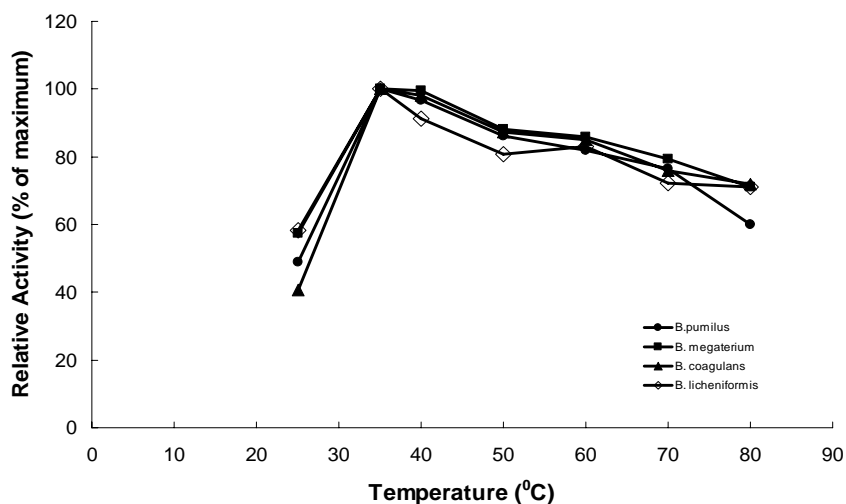

Fig. 4. Effect of temperature on phytase activities of *Bacillus* spp. The enzyme activities were assayed at various reaction temperatures for 1 h at pH 6.0 (25 °C, 35 °C, 40 °C, 50 °C, 60 °C, 70 °C and 80 °C).

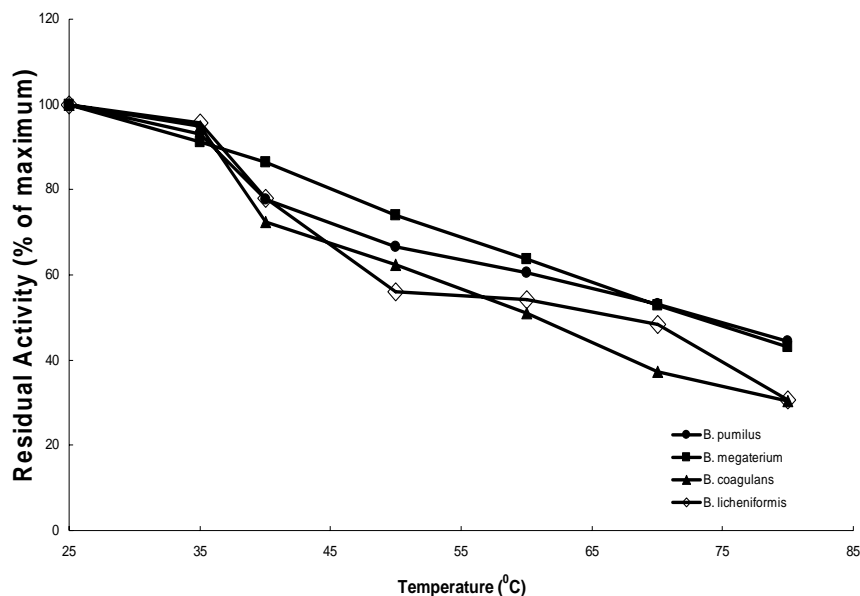

Fig. 5. Effect of temperature on stability of *Bacillus* spp. phytases. The enzymes were pre-incubated for 1 h at different temperatures and the residual activities were measured at pH 6.0 (25 °C, 35 °C, 40 °C, 50 °C, 60 °C, 70 °C and 80 °C).

B.coagulans and *B. licheniformis* . The amount of P_i released from corn meal ranged from 808 mg kg^{-1} to 1,365 mg kg^{-1} . Phytase *B. licheniformis* exhibited the highest activity which was significantly different from the rest of the treatments; however *B. coagulans* and *B. megaterium* are significantly different from each other, while the lowest was phytase *B. pumilus* (Fig.8).

D. Apparent digestibility

The apparent digestibility coefficient (ADC) values ranged from 86.29 to 88.29%. The ADC's of all treatments were not significantly different from each other ($P > 0.05$) Table2.

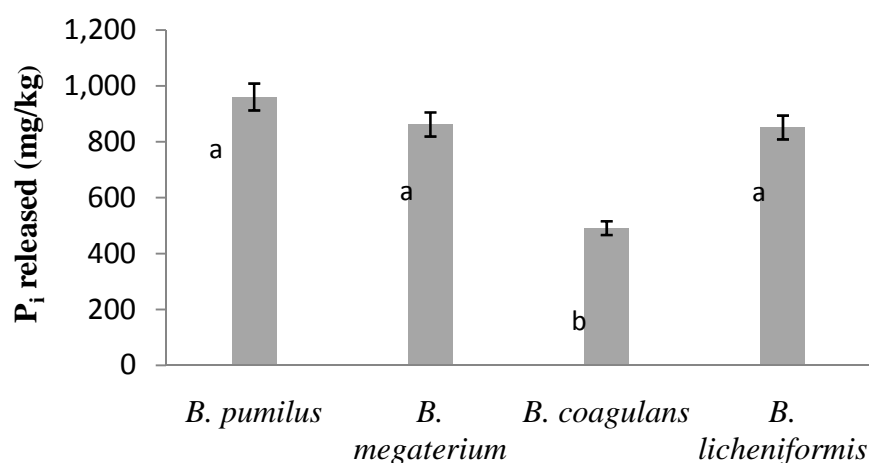

Fig. 6. The P_i released from cassava leaf meal using different bacterial phytase sources after 1 h incubation at pH 6.0 at 37 °C (300 μ l enzyme + 600 μ l substrate + 900 μ l 5% TCA). Bars represent means \pm S.D. Means with different letters are significantly different ($P < 0.05$)

Table 2. The Tukey's test result of P_i released from cassava leaf meal using different sources of bacterial phytase.

Treatment	N	Subset for alpha = 0.05	
		1	2
<i>B. coagulans</i>	3	491.2500	
<i>B. licheniformes</i>	2		858.9800
<i>B. megaterium</i>	3		862.2500
<i>B. pumilus</i>	3		961.0000
Sig.		1.000	.134

Means for groups in homogeneous subsets are displayed.

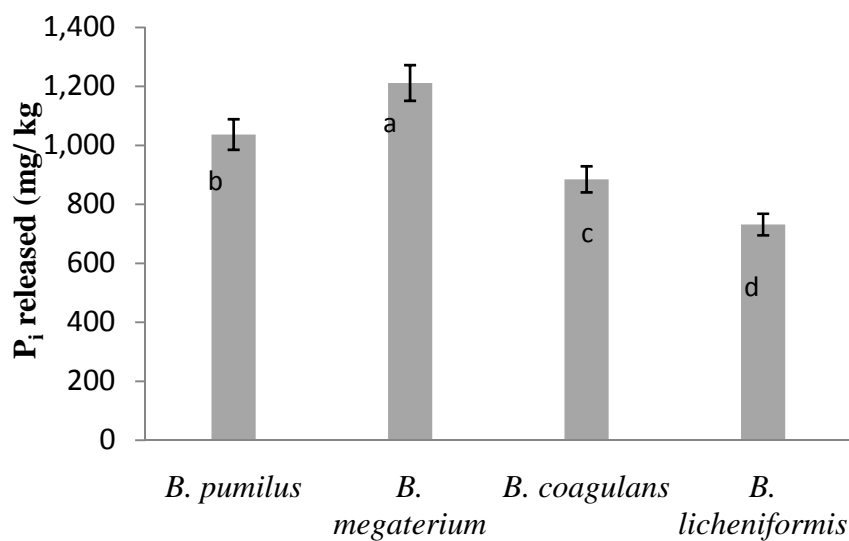

Fig. 7. The P_i released from soybean meal using different bacterial phytase sources after 1 h incubation at pH 6.0 at 37 °C (300 μ l enzyme + 600 μ l substrate + 900 μ l 5TCA). Bars represent means \pm S.D. Means with different letters are significantly different ($P < 0.05$)

Table 3. The Tukey's test result of P_i released from soybean meal using different sources of bacterial phytase.

Treatment	N	Subset for alpha = 0.05			
		1	2	3	4
<i>B. licheniformis</i>	3	7.3150E2			
<i>B. coagulans</i>	3		8.8500E2		
<i>B. pumilus</i>	3			1.0370E3	
<i>B. megaterium</i>	3				1.2118E3
Sig.		1.000	1.000	1.000	1.000

Means for groups in homogeneous subsets are displayed.

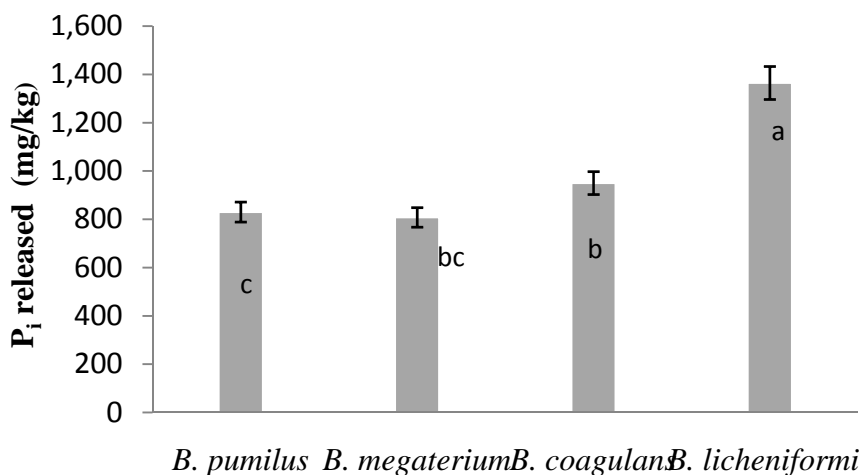

Fig. 8. The Pi released from corn meal using different bacterial phytase sources after 1 h incubation at pH 6.0 at 37 °C (300µl enzyme + 600µl substrate + 900 µl 5% TCA). Bars represent means ±S.D. Means with different letters are significantly different (P< 0.05)

Table 4. The Tukey’s test result of Pi released from corn meal using different sources of bacterial phytase.

Treatment	N	Subset for alpha = 0.05		
		1	2	3
<i>B. megaterium</i>	3	8.0775E2		
<i>B. pumilus</i>	3	8.3000E2	8.3000E2	
<i>B. coagulans</i>	3		9.4975E2	
<i>B. licheniformis</i>	3			1.3645E3
Sig.		.956	.100	1.000

Means for groups in homogeneous subsets are displayed.

Table 5. Apparent digestibility coefficient of feeds (%)

Treatments	Apparent Digestibility Coefficient (ADC) %
Control (without bacterial phytase)	87.4 ± 0.1
<i>B. pumilus</i>	86.4 ± 0.3
<i>B. megaterium</i>	88.3 ± 0.3
<i>B. coagulans</i>	86.3 ± 0.1
<i>B. licheniformes</i>	87.8 ± 0.2

The different *Bacillus spp.* produced phytase when grown in minimal medium containing sodium phytate as the sole phosphate source. These phytases are synthesized in the post-exponential phase of growth as shown in the results of the current study (Fig.1). The stationary phase induction observed suggested that phytase was not required for growth of the organism and could be produced only as a response to some nutrient limitation, (Konietzny and Greiner, 2004). Phytase formation, however, is not controlled uniformly among different bacterial species. Bacterial phytases are found to be inducible enzymes with their expression subjected to a complex regulation. The *Bacillus* phytases in the present study shared the same enzyme induction property with other *Bacillus spp.* In *Bacillus sp.* KHU-10 (Choi et al., 2001), phytase activity increase markedly after the cells reach the late stationary phase. When phosphate becomes rate limiting, growth rate begins to fall and the synthesis of the enzyme is initiated. The same mode of induction is observed in *Bacillus subtilis* (Kerovuo et al., 1998) in which phytase production is induced by the presence of phytate as the sole source of phosphate in the culture medium. This suggests that production of phytase is induced only when Pi is a limiting factor. Phytase production and activity of the soil bacterium *Klebsiella pneumonia* (Wang et al., 2004) follow the same trend in phytase production, reaching a plateau around 4-5 days of culture and dropped drastically thereafter.

In order to ensure the effectiveness of phytase to degrade phytate in the animal's digestive tract, it is important to determine the effect of pH and temperature on the enzyme's activity and stability. The low pH in the stomach which is the main functional site of feed phytases makes an enzyme with an acidic pH optimum certainly desirable. In terms of pH optima, there are two main types of phytases identified: acid phytases with an optimum pH around pH 5.0 and alkaline phytases with an optimum pH around pH 8.0, (Konietzny and Greiner, 2004). Most of the studied microbial phytases belong to the acidic ones with pH optima range of 4.0 to 5.5 (Yin et al., 2006). Phytase from the other bacterial species such as those belonging to Enterobacteriaceae family like *E. coli*, (Yin et al., 2006) *Enterobacter sp.4* (Kang et al., 2005) and *Obesumbacterium proteus* (Zinin et al., 2004) exhibit much lower pH optima (pH 3.0-4.5) and wider pH range (pH 2.0 to 5.5). In the present study, the *Bacillus* phytases demonstrated pH activity profiles that were in agreement with those from other *Bacillus* species; optimal activities of the four phytases were observed at pH 5.5-7.0 range. The same pH optima for activity are found in *Bacillus sp* KHU-10 (Choi et al., 2001) *B. subtilis* (Powar and Jagannathan, 1982; Kerovuo et al., 1998) and *B. amyloliquefaciens* (Idriss et al., 2002) while *B. laevolacticus* (Gulati et al., 2006) exhibited optimum activity at neutral to slightly alkaline pH (7.0-8.0). This activity at low pH values makes these *Bacillus* phytases suitable as feed additives for monogastric animals having stomach pH values of 2-6.

Because commercial feeds are often pelleted, a process which uses high temperatures (60-80°C) and steam, enzyme thermal stability is relevant in animal feed applications (Lei and Porres, 2003). It becomes imperative to examine the optimum temperature for reaction and thermal stability of any given phytase to determine its suitability for feed incorporation. The *Bacillus* phytases in the present study exhibited the highest activities at lower temperature (35°C) but maintained activities even in high reaction temperatures. Optimal temperature for reaction of the phytases in the present study was relatively lower compared with those of other microbial origin: 40-60°C for *Bacillus sp* KHU-10, (Choi et al., 2001) 55°C for *B. subtilis*, (Kerovuo et al., 1998) 70°C for *B.*

laevolacticus, (Gulati et al., 2006) 60°C for *E. coli*, (Yin et al., 2006) 60°C for *Pantoea agglomerans*, (Greiner, 2004) and 50°C for *Citrobacter braaki*, (Kim et al., 2003). In the light of these findings, we speculate that the *Bacillus* enzymes in this study could perform optimally or near optimally at average stomach temperature.

The thermostability of a phytase is determined by its ability to resist heat denaturation or its ability to refold into fully active conformation after heat denaturation or both; (Wyss et al., 1998). The enzymes in the present might have been partially denatured at the highest tested temperature because the activities were significantly reduced by 60-70%. Among the *Bacillus* species tested, only *B. megaterium* and *B. pumilus* exhibited relatively higher thermostability retaining activity of >50% at 70°C and >40% at 80°C.

Bacterial phytases in general have a relatively high temperature optima and thermostability compared with those of fungal origin.. *Bacillus* sp. strain DS11 (Kim et al., 1998) has a temperature optimum at 70°C, which is higher than the temperature optimum of phytases in general. It is also thermostable with 100% residual activity after 10 min incubation at 70°C (in the presence of CaCl₂). The enzyme stability of *Bacillus* sp. strain DS11 phytase is drastically reduced above 50°C in the absence of CaCl₂, whereas it is rather stable up to 90°C in the presence of CaCl₂. In the present study, the enzymes were exposed to high temperatures for 1 h which is considerably longer than the 10 min incubation time used in *Bacillus* sp DS11. This might have lead to the denaturation of the enzyme.

In the present study the apparent digestibility of the plant-based diet tested in *Oreochromis mossambicus* with and without bacterial phytase supplementation ranged from 86.3% to 88.3% in which the major plant protein source was soybean meal, cassava leaf meal and corn meal. Similar observation are made by Kamarudin et al. (1989) in red tilapia that apparent digestion coefficients of different feed ingredients with reference diet in the tested feedstuffs (rice bran, fish meal, corn meal, shrimp meal, copra meal and soybean meal) are between 63.90% and 90.72%. The proteins in all the tested feedstuff are well digested by red tilapia. It is reported that 99% of the fish meal is digested while 91.56% and 89.40% of the protein in soybean meal and corn meal are digested respectively. Comparable observations are made by Law et al. (1987) in giant gourami and in grass carp (Law, 1986).

CONCLUSIONS

The *Bacillus* phytases tested were able to release Pi from sodium phytate. Two of these enzymes (*B. pumilus* and *B. megaterium*) have high thermal stability as well as broad active and stable pH range. These results indicated that these phytases have the potential for use as feed additive for monogastric animals. Phytase activities varied between *Bacillus* strains as well as between feed ingredients. For the cassava leaf meal, Pi released was highest in *B. pumilus* but was not significantly different from those of *B. megaterium* and *B. licheniformis*. For the soybean and corn meals, *B. megaterium* and *B. licheniformis* phytases, respectively, displayed significantly the highest amount of Pi released. It further concluded that enzymes from *Bacillus megaterium* and *Bacillus pumilus* were recommended in the formulation of plant-based diets for fishes due to thermal stability and wide range of pH.

ACKNOWLEDGMENTS

The authors are grateful to the Philippine Department of Science and Technology, Philippine Council for Aquatic Marine Research and Development (DOST- PCAMRD) for the research funding. They also wish to thank Ms. Sharon Nunal and Mary Paz Aguana for the assistance in the conduct of research.

REFERENCES

- Choi, Y. M., H. J. Suh, J. M. Kim, 2001. Purification and properties of extracellular phytase from *Bacillus* sp. KHU-10. *J. Prot. Chem.* 20, 287-292.
- Craxton, A., J. J. Caffrey, W. Burkhart, S. T. Safrany, S. B. Shears, 1997. Molecular cloning and expression of a rat hepatic multiple inositol polyphosphate phosphatase. *Biochem. J.* 328, 75-81.
- Engelen A.J., F. C. van der Heeft, P. H. Randsdorp, E. L. Smith, 1994. Simple and rapid determination of phytase activity. *J AOAC Int* 77, 760-4.
- Feed Development Section, 1994. Feeds and Feeding of Milkfish, Nile Tilapia, Asian Sea Bass and Tiger Shrimp. SEAFDEC Aquaculture Department, Tigbauan, Iloilo, Philippines. 97pp.
- Furukawa, L.H., H. Tsukahara 1966. On the acid digestion of chromic oxide as an index substance in the study of digestibility of fish feed. *Bull. Japan, Soc. Sci. Fish.*, 32: 502 – 506.
- Greiner, R., 2004. Purification and properties of a phytate degrading enzyme from *Pantoea agglomerans*. *The Prot. J.*, 23, 567-576.
- Greiner, R., U. Konietzny K. D. Jany 1993. Purification and characterization of two phytases from *Escherichia coli*. *Arch. Biochem Biophys* 303, 107 – 113.
- Greiner, R., M. Larsson-Alminger, 2001. Stereospecificity of *myo*-inositol hexakisphosphate dephosphorylation by phytate-degrading enzymes of cereals. *J. Food Biochem.* 25,229-248.
- Gulati, H. K., B. S. Chadha, H. S. Saini, 2006. Production and characterization of thermostable alkaline phytase from *Bacillus laevolacticus* isolated from rhizosphere soil. *J. of Indust. Microbiol. Biotechnol.* 34, 91-98.
- Howson, S. J., R. J. Davis 1983. Production of phytate-hydrolysing enzyme by fungi. *Enzyme Microbiol. Technol.* 5, 377-382.
- Idriss, E. E., A. Farouk, R. Greiner, H. Bochow, R. Borris, 2002. Extracellular phytase activity of several *Bacillus amyloliquefaciens* FZB45 contributes to its plant-growth-promoting effects. *Microbiol.* 148, 2097-2109.
- Kamarudin, M. S., K. M. Kaliapan, S. S. Siraj 1989 (*In. S. S. De Silva* (ed)). The digestibility of several feedstuffs in red tilapia. *Fish Nutrition Research in Asia. Proceedings of the Third Asian Fish Nutri. Network Meeting. Asian Fish. Soc. Spec. Publ.* 4, 166 p. Asian Fish Soc., Manila Phils. P 118 – 122.

- Kerovuo, J., M. Lauraeus, P. Nurminen, N. Kalkkinen, J. Apajalati, 1998. Isolation, characterization, molecular gene cloning, and sequencing of a novel phytase from *Bacillus subtilis*. *Appl. Environ. Microbiol.* 64, 2079 – 2085.
- Kerovuo, J. 2000. A Novel Phytase from *Bacillus*. Characterization and Production of the Enzyme. Academic Dissertation Danisco Cultor Innovation, Kantvik, Finland pp.69
- Kim, J.D., S. J. Knushik, J. Breque 1998. Nitrogen and phosphorus utilization in rainbow trout (*Oncorhynchus mykiss*) fed diets with or without fish meal. *Aqua. Living Res.* 11: 261 – 264.
- Kim, Y.O., J. K. Lee, H. K. Kim, J. H. Yu, T. K. Oh 1998. Purification and properties of a thermostable phytase from *Bacillus* sp. DS11. *Enzyme Microbiol. Technol.* 22, 2 – 7.
- Kim, H. W., Y. O. Kim, J. H. Lee, K. K. Kim, J. L. Kim, 2003. Isolation and characterization of a phytase with improved properties from *Citrobacter braakii*. *Biotechnol. Lett.* 25, 1231 – 1234.
- Konietzny, U., R. Greiner, 2004. Bacterial phytase: Potential application, *in vivo* function and regulation of its synthesis. *Brazilian J. of Microbiol.* 35, 11-18.
- Law, A. T. 1986. Digestibility of low –cost ingredients in pelleted feed by grass carp (*Ctenopharyngodon idella*). *Aquacult.* 51, 97 – 103.
- Law, A. T., K. K. Chong, K. J. Ang 1987. Digestibility of ingredients in a pelleted feed by giant gourami , *Osphronemus goramy* (Lacepede). *In. R. I. Hutagalung, C. P. Chen, W. M. Wan Embong, A. T. Law, S. Sivarajasingam(eds.)Proceedings 10th Annual Conference Malaysian Society of Animal Production.* Pp 206 – 209.
- Lazado, C. C., C. M. A. Caipang, S. Gallage, M. F. Brinchmann, V. Kiron 2010. Responses of Atlantic cod *Gadus morhua* head kidney leukocytes to phytase produced by gastrointestinal – derived bacteria. *Fish Physio. Biochem* 36, 883 – 891.
- Lei, X. G., J. M. Porres, 2003. Phytase enzymology, applications, and biotechnology. *Biotechnol. Letters.* 25, 1787 – 1794.
- Lovell, R.T. 1975. Laboratory Manual for Fish Feed Analysis and Fish Nutrition Studies. Auburn University. 34 – 35.
- Lowry, O. H., N. J. Rosebrough, A. L. Farr, R. J. Randall, 1951. Protein measurement with the Folin phenol reagent. *J. Biol. Chem.* 193,265-275.
- Nolan, K. B., P. A. Duffin, D. J. McWeeny 1987. Effects of phytate on mineral bioavailability. In vitro studies on Mg, Ca, Fe, Cu, and Zn (also CD) solubilities in the presence of phytate. *J. Sci. Food Agric.* 40:79–85.
- Pearson, D. 1977. The Chemical Analysis of Foods. 7th Ed. Chem. Pub. Co. N. Y. 23 – 24.
- Powar V. K., V. Jagannathan 1982. Purification and properties of phytate – specific phosphatase from *Bacillus subtilis* . *J. Bacteriol.* 151, 1102 – 1108

- Reddy, N.R., S.K. Sathe, D. K. Salunkhe 1982. Phytates in legumes and cereals. Pages 1 – 92 in C.O. Chichester, E.M. Mark and G.F. Stewart, editors. *Advances in Foods Research*. Aca. Press, New York, New York, USA.
- Richardson, N. L., D.A. Higgs, R. M. Beams, J.R. McBride 1985. Influence of dietary calcium, phosphorus, zinc and sodium phytate level on cataract incidence, growth and histopathology in juvenile Chinook salmon (*Oncorhynchus tshawytscha*). *J. of Nutr.* 115: 553 – 567.
- Segueilha, L., C. Lambrechts, H. Boze, G. Moulin, P. Galzy, 1992. Purification and properties of the phytase from *Schwanniomyces castelii*. *J. Ferment. Bioeng.* 74, 7-11.
- Shimizu, M. 1992. Purification and characterization of phytase from *Bacillus subtilis* (natto) N-77. *Biosci. Biotechnol. Biochem.* 56, 1266-1269.
- Simell, M., M. Turunen, J. Piironen, T. Vaara 1989. Feed and food applications of phytase. Lecture at 3rd Meet. *Industrial Applications of Enzymes*. Barcelona, Spain.
- Ullah, A. H. J. 1988. Production, rapid purification and catalytic characterization of extracellular phytase from *Aspergillus ficuum*. *Prep. Biochem.* 18, 443-458.
- Wang, X., S. Upatham, W. Panbangred, D. Isarangkul, P. Summpunn, S. Wiyakrutta, V. Meevotism, 2004. Purification, characterization, gene cloning and sequence analysis of a phytase from *Klebsiella pneumonia* subsp. *Pneumoniae* XY-5. *Science Asia.* 30, 383-390.
- Wyss M., L. Pasamontes, R. Remy, J. Kohler, E. Kuszniir, M. Gadiant, F. Muller, A. Van Loon 1998. Comparison of the thermostability properties of three acid phosphatases from molds: *Aspergillus fumigatus* phytase, *A. niger* phytase, and *A. niger* pH 2.5 acid phosphatase. *Appl Environ Microbiol* 64, 4446-51.
- Yamada, K., Y. Minoda, Y. Yamamoto 1968. Phytase from *Aspergillus terreus*. Production, purification and some general properties of the enzyme. *Agric. Biol. Chem.* 32, 1275-1282
- Yin, Q.Q., Q. H. Zheng, X. T. Kang, 2006. Biochemical characteristics of phytases from fungi and the transformed microorganism. *Anim. Feed Sci. and Technol.* 132 (2007) 341-350.
- Yoon, S.J., Y. J. Choi, H. K. Min, J. W. Kim 1996. Isolation and identification of phytase producing bacterium, *Enterobacter sp.* 4 and enzymatic properties of phytase enzyme. *Enz Microb. Technol.* 18, 449 – 454.
- Zinin, N. V., A. V. Serkina, M. S. Gelfand, A. B. Shevelev, S. P. Sinepky, 2004. Gene cloning, expression and characterization of novel phytase from *Obesumbacterium proteus*. *FEMS. Microbiol. Lett.* 236, 283 – 290

ISOLATION AND EXPRESSION ANALYSIS OF *Hydroxyphenylpyruvatereductase (HPPR) DERIVED FROM Orthosiphonaristatus*

Hairul Azman Roslan* and Zuliza Ahmad

Genetic Engineering Laboratory, Department of Molecular Biology, Faculty of Resource Science & Technology, Universiti Malaysia Sarawak, 94300 Kota Samarahan, Sarawak

* Corresponding author: hairulroslan@hotmail.com

ABSTRACT

Herbal products are getting more popular as alternative medicines and food supplements. The therapeutic effects of herbal medicines are mainly attributed to their bioactive secondary metabolites. *Orthosiphonaristatus*, locally known as 'MisaiKucing', is known for its various health benefits. One of the main chemical constituent of *O. aristatus* is rosmarinic acid, a plant polyphenol that has been proven to have antioxidant, anti-inflammatory and antimicrobial activities. Hydroxyphenylpyruvatereductase (HPPR) is one of the enzymes involved in rosmarinic acid biosynthetic pathway. Here we report on the effect of UV on HPPR expression and the isolation of a full length *HPPR* cDNA from *O. aristatus* via rapid amplification of cDNA ends polymerase chain reaction. An increase in the expression was found when the plant was exposed to UV and detected via the expression of HPPR transcript. A 1116 bp nucleotide putative cDNA was isolated corresponding to 307 predicted amino acid. We have also isolated the 5' and 3' untranslated regions with a length of 54 bp and 123 bp respectively. Sequence similarity analysis was performed against NCBI genebank and the BLAST result showed that the putative *HPPR* cDNA isolated from *O. aristatus* exhibited high similarities with HPPR cDNA of *Perillafrutescens*, *Salviaofficinalis*, *Salviamiltiorrhiza* and *Solenostemonscutellariodes*.

Keywords: *Orthosiphonaristatus*, rosmarinic acid, hydroxyphenylpyruvatereductase (HPPR), rapid amplification of cDNA ends (RACE)

INTRODUCTION

Orthosiphonaristatus [syn.: *O. grandiflorus*, *O. spicatus*, *O. stamineus*] is locally known as "Misai Kucing" belonging to the family Lamiaceae. It is a perennial herb that can grow to about 0.4 to 1.5 m high. The leaves are green and simple with a lanceolate leaf blade (Jaganath and Ng, 2000). The flowers have long protruding stamens, making it look like cat's whiskers (Figure 1). It has been used in South East Asia countries such as Malaysia, Indonesia, Thailand and Vietnam in traditional medicine for treatment of fever, epilepsy, gallstones, hepatitis, rheumatism, hypertension, syphilis, gonorrhea, tonsillitis, hepatitis, gout and diabetes (Akowuah *et al.*, 2005, Kiong *et al.*, 2008).

Various ranges of scientific studies support the traditional use of the plant. Studies have showed that the plant exhibited anti-pyretic activity (Yam *et al.*, 2009), radical scavenging or antioxidant (Akowuah *et al.*; 2005, Khamsah *et al.*, 2006), anti-apoptotic (Abdelwahabet *et al.*, 2011), anti-microbial (Tong *et al.*, 2011), anti-bacterial activity, anti-fungal activity (Hossain *et al.*, 2008) and chemo-preventive activity (Salleh *et al.*, 2011). More than 20 compounds have been isolated and identified in *O. aristatus* (Tezuka *et al.*, 2000) and rosmarinic acid is one of the major constituent (Chin *et al.*, 2009). Rosmarinic acid (RA) is commonly found within the families Boraginaceae and Lamiaceae (Li *et al.*, 2005). RA has been proven to have anti-microbial, anti-viral, anti-pyretic and anti-oxidant effects (Petersen and Simmonds, 2003). UV is an abiotic stimulus that has the potential to induce accumulation of secondary metabolites which in turn affect numerous physiological functions (Paul and Gwynn-Jones, 2003; Matsuura *et al.*, 2013). A study by Luis *et al.* (2007), showed significant increase of rosmarinic acid concentration in rosemary when exposed to UV-B. Meanwhile, hydroxyphenylpyruvate reductase (HPPR) is one of the enzymes that are involved in the biosynthetic pathway of RA production and involved in reducing hydroxyphenylpyruvates to hydroxyphenyllactates in dependence of NAD(P)H (Petersen *et al.*, 2009).



Figure 1: Plant and flowers of *Orthosiphon aristatus* (Courtesy Ahmad, Z)

Here we report the findings of the isolation of a full length *HPPR* cDNA and preliminary correlation study looking at the expression of *HPPR* gene and exposure of *O. aristatus* to ultraviolet.

MATERIALS & METHODS

A. Plant material

The *O. aristatus* plant samples were grown from cuttings and were cultivated in Universiti Malaysia Sarawak (UNIMAS) to ensure that the plant is kept fresh. Prior to RNA extraction, all plant materials were rinsed with water, surface sterilized with 70% ethanol for 1 minute and final rinse with distilled water.

B. RNA extraction and Reverse transcription (RT)

Total RNA was isolated using the modified Gasic *et al.* (2004) method. The RNA was then quantified by spectrophotometric analysis at wavelength 230, 260, 280 and 320 nm using Ultrospec 1100 pro (Amersham Biosciences) and visualized on ethidium bromide-stained 1% agarose gel to visualize the RNA.

The total RNA was treated with DNase I (Fermentas) and reverse transcribed using RevertAid Reverse Transcriptase (Fermentas). First strand cDNA were synthesized using primer oligo (dT)₁₅-ACP using standard procedure.

C. Primer design

Gene specific primers were designed based on alignment of HPPR mRNA from other plant species obtained from the NCBI database. The primers were designed using the programme Primer3, based on *Solenostemon scutellarioides* mRNA sequence (AJ507733). Several other primer pairs were designed and used to determine the internal fragment and amplification of the 3' and 5' RACE.

D. Polymerase chain reaction (PCR)

Gene specific forward primer haHppr-f and reverse primer haHppr-r was used to amplify the internal fragment of HPPR. PCR was performed in a total volume of 20 µl containing 2X GoTaq® Green Master Mix (Promega), forward and primer, nuclease-free water and cDNA template. The PCR amplification was conducted in a thermal cycler with 35 cycles at annealing temperature of between 50-70°C.

Positive control assay was done using the elongation factor 1 alpha (EF-1α) mRNA sequence (Nicotet *et al.* 2005).

E. Rapid amplification of cDNA ends (RACE)

For the generation of cDNA 3'-end, the cDNA used was synthesized using primer oligo (dT)₁₅ ACP. The 3' end were initially amplified using modified touchdown PCR using oligo (dT)₁₅ ACP and SolsHppr-f. The PCR products were diluted and nested PCR was performed using primer oligo (dT)₁₅ ACP and haHppr-f to increase specificity of the PCR amplification.

For the 5' RACE, reverse transcription was done as described above and using a gene specific primer haHppr-r instead of an Oligod(T)₁₅ ACP primer in combination with zaHppr01-f primer.

F. Purification of PCR products and Cloning process

The PCR products were purified using GF-1 gel DNA Recovery Kit (Vivantis) and then ligated into pGEM-T vector (Promega) using the T4 ligase and transformed into *Escherichia coli* XL-1 Blue according to standard procedure.

G. Plasmid extraction and Sequencing

The plasmids were isolated from transformed colonies using GF-1 Plasmid DNA Extraction Kit (Vivantis) and sent for sequencing to First BASE Laboratories Sdn Bhd. (Malaysia). CLC Sequence Viewer software was used to analyse the HPPR sequence. Confirmation of sequence is done by homology search via NCBI Genebank.

H. UV treatment and cDNA analysis

For the UV treatments, semi-quantitative RT-PCR was done to investigate the expression of *O.aristatus*HPPR under different UV exposure. The plants were exposed under UV for 15 minutes, 30 minutes, 45 minutes and 60 minutes. Total RNA was then extracted from leaves of *O.aristatus*, reversed transcribed into cDNA and amplified using *HPPR*internal primers.

RESULTS AND DISCUSSION

The large scale RNA extraction from the leaves of *O. aristatus* yielded total RNA of approximately 200 µg of total RNA per g of fresh weight. Figure 2 shows the agarose gel picture of the total RNA extracted from several samples.

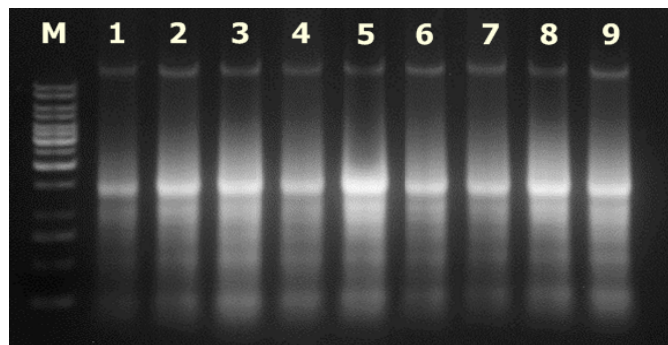

Figure 2: Agarose gel electrophoresis result of *O. aristatus* total RNA extraction. Lane M; 1 kb ladder marker, Lane 1-9; plant sample 1-9.

Amplification using specific primer haHppr-f and haHppr-r produced a fragment of approximately 600 bp. Sequence analysis on the fragment showed 91% similarities to *S.scutellarioides*HPPRmRNA. The 3'RACE-PCR produced a fragment of approximately 800 bp including a poly-A tail at the 3'-end. Sequencing analysis showed 89 to 91% similarities with other plants HPPR.

Meanwhile, 5'RACE-PCR using zaHppr01-f and haHppr-r produced a fragment approximately 750bp. The nucleotide sequence analysis showed 86% similarities to other plant species. Figure 3 shows the HPPR amino acid alignment resulting from cDNA amplification in *O. aristatus*.



Figure 3: A schematic representation of the amplified fragments. Fragment A is the full length of *HPPR* gene of *Solenostemon scutellarioides*; B is the internal fragment of *HPPR* gene in *O. aristatus*; C is the 3' end and D is the 5' end.

The 5'-end and 3'-end nucleotide sequence of *O. aristatus* HPPR were merged. A 1116bp nucleotide sequence of *HPPR* cDNA was produced including 54 bp and 123 bp of the 5' and 3' untranslated regions. The open reading frame translates to 307 amino acids with similarities between 86 to 89% to other HPPR genes (Table 1).

The preliminary work to investigate the correlation between HPPR expression and exposure to UV was done via RT-PCR analysis. Total RNA was extracted at exposure times of 15 minutes, 30 minutes, 45 minutes and 60 minutes. An RT-PCR was undertaken using specific *HPPR* internal primers and results showed increase in the *O. aristatus* HPPR cDNA detected upon exposure to UV. The amplification intensities increased with the time of UV exposure (data not shown).

Table 1: BLAST search result for the putative *O. aristatus* HPPR cDNA.

Plant	Length (bp)	GenBank accession number	Homology (%) [*]
<i>Perilla frutescens</i>	942	HM587131.1	89 (830/931)
<i>Perilla frutescens</i>	426	HM152567.1	89 (381/429)
<i>Salvia officinalis</i>	890	EU837265.1	87 (777/896)
<i>Salvia miltiorrhiza</i>	1174	DQ26651.1	86 (870/1007)
<i>Salvia miltiorrhiza</i>	1117	DQ099741.1	86 (870/1007)
<i>Salvia miltiorrhiza</i>	3564	EF458148.1	88 (462/524)
<i>Solenostemon scutellarioides</i>	1127	AJ507733.2	87 (877/1008)

* The percentage is based on the BLAST nucleotide search. Numbers in bracket indicate the number of bases (query/subject) that was compared.

CONCLUSION

A complete HPPR cDNA of *O. aristatus* has successfully been isolated with 1116 bp in nucleotide length and 307 deduced amino acid. The amino acid sequence shows high similarities to HPPR of other plants. UV treatments have showed correlation of increased *HPPR* transcripts with longer exposure to UV.

ACKNOWLEDGEMENT

The authors would like to acknowledge the research support by Universiti Malaysia Sarawak for the work undertaken with Faculty-funded research.

REFERENCES

- Abdelwahab, S.I., Mohan, S., Elhassan, M.M., Al-Mekhlafi, N., Mariod, A.A., Abdul, A.B., Abdulla, M.A., & Alkharfy, K.M. (2011). Antiapoptotic and antioxidant properties of *Orthosiphonstamineus* Benth (Cat's Whiskers): intervention in Bcl-2-mediated apoptotic pathway. *Evidence-Based Complementary and Alternative Medicine*. DOI:10.1155/2011/156765.
- Akowuah, G.A., Ismail, Z., Norhayati, I., & Sadikun, A., (2005). The effects of different extraction solvents of varying polarities on polyphenols of *Orthosiphonstamineus* and evaluation of the free radical-scavenging activity. *Food Chemistry*, 93, 311-317.
- Chin, J.H., Hussin, A.H., & Ismail, S. (2009). Effect of *Orthosiphonstamineus* leaf extracts on hepatic cytochrome P450, UGT and GST activity in STZ-induced diabetic rats. *Journal for the Advancement of Science and Arts*, 1(1).
- Gasic, K., Hernandez, A., & Korban, S.S. (2004). RNA extraction from different apple tissues rich in polyphenols and polysaccharides for cDNA library construction. *Plant Molecular Biology Reporter*, 22:437a-437g.
- Hossain, M.A., Ismail, Z., Rahman, A., & Kang, S.C. (2008). Chemical composition and anti-fungal properties of the essential oils and crude extracts of *Orthosiphonstamineus* Benth. *Industrial Crops and Products*, 27:328-334.
- Jaganath, I.B., & Ng, L.T. (2000). Herbs: the green pharmacy of Malaysia. Malaysian Agricultural Research and Development Institute.
- Khamsah, S.M., Akowuah, G., & Zhari, I. (2006). Antioxidant activity and phenolic content of *Orthosiphonstamineus* Benth from different geographical origin. *Journal of Sustainability Science and Management*, 1(2):14-20.
- Kiong, A.L.P., Lai, A.G., Hussein, S., & Harun, A.R. (2008). Physiological responses of *Orthosiphonstamineus* to gamma radiation. *American-Eurasian Journal of Sustainable Agriculture*, 2(2):135-149.
- Luis, J.C., Pérez, R.M., & González, F.V. (2007). UV-B radiation effects on foliar concentrations of rosmarinic and carnosic acids in rosemary plants. *Food Chemistry*, 101:1211-1215.
- Li, W., Koike, K., Asada, Y., Yoshikawa, T., and Nikaido, T. (2005). Rosmarinic acid production by *Coleus forskohlii* hairy root cultures. *Plant Cell, Tissue and Organ Culture*, 80, 151-155.
- Matsuura, H.N., Costa, F., Yendo, A.C.A. & Fett-Neto, G. (2013). Photoelicitation of bioactive secondary metabolites by ultraviolet radiation: mechanisms, strategies and applications. In Chandra, S., Lata, H. & Varma, A. (eds), *Biotechnology for Medicinal Plants*, Springer-Verlag Berlin Heidelberg, pp 171-190.

- Nicot, N., Hausman, J. Hoffmann, L. & Evers, D. (2005). Housekeeping gene selection for real-time RT-PCR normalization in potato during biotic and abiotic stress. *Journal of Experimental Botany*, 56(421):2907-2914.
- Paul, N.D. & Gwynn-Jones, D. (2003). Ecological roles of solar UV radiation: towards an integrated approach. *Trends in Ecology and Evolution*, 18(1):48-55.
- Petersen, M., & Simmonds, M.S.J. (2003). Rosmarinic acid. *Phytochemistry*, 62, 121-125.
- Petersen, M., Abdullah, Y., Benner, J., Eberle, D., Gehlen, K., Hucherig, S., Janiak, V., Kim, K.H., Sander, M., Weitzel, C., & Wolters, S. (2009). Evolution of rosmarinic acid biosynthesis. *Phytochemistry*, 70, 1663-1679.
- Salleh, S.A., Rajab, N.F., Abdullah, N.R., Ismail, Z., Mouatt, P., Dowell, A., & Muhamad, S. (2011). *In vitro* chemopreventive activity of an ethyl acetate fraction derived from hot water extract of *Orthosiphonstamineus* in HepG2 cells. *Journal of Medicinal Plants Research*, 5(10):1892-1899
- Tezuka, Y., Stampoulis, P., Banskota, A.H., Awale, S., Tran, K.Q., Saiki, I., & Kadota, S. (2000). Constituents of the Vietnamese medicinal plant *Orthosiphonstamineus*. *Chem. Pharm. Bull.*, 48(11):1711-1719.
- Tong, W.Y., Darah, I., & Latiffah, Z. (2011). Antimicrobial activities of endophytic fungal isolates from medicinal herb *Orthosiphonstamineus* Benth. *Journal of Medicinal Plants Research*, 5(5):831-836.
- Yam, M.F., Ang, L.F., Basir, R., Salman, I.M., Ameer, O.Z., & Asmawi, M.Z. (2009). Evaluation of the anti-pyretic potential of *Orthosiphonstamineus* Benth standardized extract. *Inflammopharmacology*, 17:50-54.

EVALUATION OF THE EFFECT OF AZOSPIRILLUM – LIKE BACTERIA ON THE GROWTH AND YIELD OF GREEN ONION (*Allium cepa* L.)

Carlos E. Lacamento,
Sultan Kudarat State University Philippines
c_lacamento@yahoo.com

ABSTRACT

A nursery and two field experiments were conducted to test the effectiveness of a nitrogen fixing inoculants bacteria with a local brand named bio-fertilizer on the growth and yield of green onion. The bacteria were isolated from the roots of talahib (*Saccharum spontaneum* L.), a grass relative of sugar cane, and which had been shown to enhance the growth and yield of rice, corn, sugar cane and some vegetable species. The nursery experiment and one of the field tests were conducted in the CLSU experimental station (Maligaya clay), while the other field trial was in BIOTECH demo farm, UPLB (Lipa clay loam). The following treatments were used 1) uninoculated control, 2) bio-fertilizer alone, 3) Full fertilizer rate of 120-60-60, 4) 60-30-30, 5) 120-60-60 + bio-fertilizer and 6) 60-30-30 + bio-fertilizer. The nursery experiment showed that green onion could be successfully raised in pots with minimum expense through inoculation with bio-fertilizer alone or in combination with 60-30-30. Plants inoculated with bio-fertilizer alone improved the fresh weight of the test plant by 134.40% over the control while the plants that were inoculated with bio-fertilizer + 60-30-30 gave 149.7% increase. Post soil analysis suggests that P-content decrease from 7ppm to 1ppm in the unfertilized but inoculated pots while the P in the fertilized posts increased. As in the pot experiment, a decrease in the P content of green onions after harvest was observed in both field experiments.

Keywords: *Green onion, Azospirillum, inoculants, bacteria, inoculation).*

INTRODUCTION

The Medium Term Development Plan of the Department of Agriculture (MTDP-DA) had identified priority programs that have high potential contributions to agro-industrial development of the country. These programmed for one focused on the promotion of production of high value crops that have high demand both for local and export consumptions. Among these crops, onion was identified to be a priority vegetable crop topping the list of vegetable commodity in terms of volume exported to other countries. The high export demands for onion proved to be a good reason for increasing production locally especially that the harvest period of onions in the country coincides with the lean month in importing countries. However, the current international market scenario demands for an efficient production system. High competition from other exporting countries needs to be addressed through improved product quality and lowered production cost. Fortunately, different strategies are included in the MTPD-DA

that would help farmers increase their productivity and improve competitiveness. Such strategy is promoting the utilization/application of different ago-technologies that are affordable and effective to local conditions.

OBJECTIVES OF THE STUDY

To fill the information necessary for an efficient technology adaptation for onions, this study was conducted to assess the potential of bio-fertilizer inoculation in reducing inorganic N-application in green onions. Specifically, the following objectives are considered:

1. Evaluate the response of green onion to bio-fertilizer inoculation grown in two soils;
2. Determine the physiological response of green onion to bio-fertilizer inoculation;
3. Assess the interaction between inorganic fertilizer and bio-fertilizer on the growth and yield of green onions; and
4. Determine the contribution of bio-fertilizer to the N-nutrition of green onions.

SIGNIFICANCE OF THE STUDY

One of the technologies that is proven effective is supplementing inorganic N fertilizer is the bio-fertilizer technology developed by Umali-Garcia in 1996. It is a bio-fertilizer technology that can reduce N-fertilizer input by 35-75% and enhance yield of rice, corn and sugarcane.

Bio-fertilizer inoculants have been recognized in improving rice and corn and at the same time lessen incidence of pests and diseases.

Very little research attempts have been conducted to test the efficacy of bio-fertilizer on different high value crops in the Philippines. However, there are on-going studies that aim to utilize the bio-fertilizer technology on high value vegetables to assess the efficacy of the technology not only on yield but also on their quality. Only one test has been conducted to assess the effect of bio-fertilizer on onion. However, some Cavite onion growers have reported very favorable effects of bio-fertilizer especially on yield and keeping quality in storage (Garcia, pers. Comm..2002). Onion is one of the most important crops grown after rice in Cavite, Batangas, Nueva Ecija and Batanes. For this reason, more background knowledge is necessary especially on the response of onion to the interaction of bio-fertilizer with levels of inorganic fertilizer and possibly organic fertilizers. This would somehow demonstrate the amount of inorganic input that could be substituted for or complemented by inoculation.

MATERIALS AND METHODS

To assess the comparative effectiveness of BIO-N inoculation and inorganic fertilizer on the growth and yield of green onions, three experiments were conducted. Experiment 1 was an inoculation test under screen house conditions using Maligaya clay, and the two experiments were set out in the field of onion growing area in Central Luzon State University (CLSU), Nueva Ecija and in the BIOTECH demo farm at UP Los Banos, college Laguna.

A. Experiment 1: Study on the Effectiveness of BIO-N Inoculation on Green Onion under Screenhouse Condition

A locally cultivated variety of green onion was used in the preliminary study for its response to bio - fertilizer inoculation under nursery condition. The particular bio - fertilizer inoculants contains one of the talahib nitrogen fixing Azospirillum-like strains. The effect of inoculation was tested using soil samples collected from Central Luzon State University experimental site in Nueva Ecija. Twenty-four earthen pots with size of 22 x 18 cm were used in the experiment and laid out following the Completely Randomized Design. Six treatments: Uninoculated control, bio - fertilizer alone, Full Recommended Rate of Inorganic Fertilizer (FRR) of 120-60-60kg/ha, ½ FRR (60-30-30 kg/ha), 120-60-60kg/ha +bio - fertilizer, and ½ FRR (60-30-30) + bio - fertilizer replicated four times were evaluated. Five kilograms of soil that was passed through a 2 mm sieve was dispensed into a 10” clay pot. 200 grams (one pack) of was mixed with one liter of water to form a slurry. The roots of onion seedlings were pruned and dipped into the slurry and used as inoculants. Uniform seedlings were selected and roots were pruned and dipped into the slurry for 30 minutes prior to transplanting. Three seedlings were transplanted to each of the pots containing the 5-kg soil.

All the required N, P and K were applied basally in the form of urea and complete fertilizer (14-14-14) the fertilizer materials were evenly mixed and applied using the spot method. Watering was done when necessary.

PLANT ESTABLISHMENT

Seeds of green onions were germinated in a semi-sterile condition using a soil-sand-sawdust mixture (1:1:1 ratio). The seedlings were maintained for six weeks prior to transplanting in the field. Uniform seedlings were used in the experiments. Irrigation and other agronomic practices were employed whenever necessary.

TREATMENT APPLICATION

The NPK requirements were computed based on the recommended rate of fertilizer for the two soil types. NPK was sourced from urea and complete fertilizer (14-14-14) and applied into the soil prior to transplanting. Bio – fertilizer inoculation was done by soaking the roots of seedlings into slurry for 30 minutes prior to transplanting.

PARAMETERS GATHERED

1. Plant height at harvest.
2. Number of tillers per plant.
3. Fresh weight per plant.
4. Dry weight of shoot and root.
5. Shoot and Root N uptake-
6. Soil analysis

The following soil attributes were obtained:

- a. pH
- b. organic matter
- c. Total N
- d. Available P-Bray P₂
- e. Exchangeable K-Flame photometer method
- f. Microbial load per gram of soil-Dilution technique was used in microbial counting.
7. Light Microscopy and Electron Microscopy - Fresh roots were collected and fixed in

Formalin acetic acid alcohol. Specimen were prepared following the standard protocols for Scanning Electron Microscopy (SEM). Treated roots were fixed in FAA (Formalin Acetic acid Alcohol solution) and washed three times when 0.1M Phosphate buffer, pH 6.8.

STATISTICAL ANALYSIS

All data were statistically analyzed using IRRISTAT 301 statistical tool. In case of significance, the Duncan's Multiple Range Test was used in comparing treatment means.

RESULTS AND DISCUSSION

A. Experiment 1: Study on the Effectiveness of bio - fertilizer Inoculation on Green Onion under Screenhouse Condition

1. Growth Response

Plant height and number of tillers are the most commonly measured growth response on the effect of treatments on clump forming crops such as banana, sugarcane and bunching onions. Results showed that all the treatments did not significantly differ in plant height and number of tillers (Figs. 1-3) but improved fresh weight of green onion by 134.40% over the control (Table 1). The least fresh weight was observed in the control plants with a mean of 8.75 g/plant while the mean of all treatments was 20.51g/plant. With the bio – fertilizer inoculation alone, the fresh weight had an average of 17.77g/plant which is a 103.08% increase over the control. The highest increase of 153.82% was detected in the fully fertilized pots but this was statistically the same as the BIO-N inoculated pots. In fact the application of bio - fertilizer in the presence of only ½ of the N dosage yielded a 149.40% increase (Table 1). From these results, growing onion in pot under described condition can be possible with minimum expense especially with bio - fertilizer inoculation by itself or in combination with only ½ of the recommended full fertilizer rate.

Table 1. Effect of bio - fertilizer inoculation in the presence or absence of inorganic fertilizer on growth and yield of green onion raised under nursery condition using Maligaya soil.

TREATMENTS	FRESH WEIGHT (g/plant)	NO. OF TILLERS/ PLANT	PLANT HEIGHT (cm)
Control	8.75b	5.00a	28.62a
Bio - fertilizer	17.77a (103.08)	6.50a	34.91a
120-60-60 NPK	22.21a (153.82)	5.00a	38.17a
60-30-30 NPK	21.06a (140.68)	6.25a	37.79a
120-60-60 NPK + bio - fertilizer	19.66a (124.68)	5.75a	35.08a
60-30-30 NPK + bio - fertilizer	21.85a (149.40)	5.25a	37.92a
Mean of treated pots	20.51 (134.40)	5.75 (15.00)	36.77 (28.49)

Means in a column followed by the same letter are not significantly different at $P>0.05$ Figures in () are % increase over control.

The lowest of oven dry weight of shoots was also recorded in the control plants with 4.92 g/plant but this was statistically similar to the shoot dry weight of fertilized plants that received bio - fertilizer. Bio - fertilizer inoculation improved shoot dry weight by 41.86%, but this was comparable with those fully or partially fertilized with inorganic fertilizer. Likewise, pots without N were improved by 27.27% with bio - fertilizer inoculation relative to the control plants. A mean increase of 55.9% treated plants over the control was exhibited.

The same trend was demonstrated in shoot N or $\frac{1}{2}$ of FRR was the most economical. This suggests that bio - fertilizer inoculation can substitute for the fertilizer requirement of green onion (Table 2).

Table 2. Shoot biomass, N-content and N-uptake of onion shoots grown in Maligaya clay under potted condition.

TREATMENTS	FRESH WEIGHT (g/plant)	NO. OF TILLERS/ PLANT	PLANT HEIGHT (cm)
Control	4.92b	1.65c	8.16b
Bio – fertilizer	6.98 (4.86)	2.18 (27.27)	15.02a (84.06)
120-60-60 NPK	6.58a	2.59ab (56.96)	16.72a (104.90)
60-30-30 NPK	6.53a	2.85a (70.90)	18.33a (124.63)
120-60-60 NPK + bio – fertilizer	5.98ab	2.58ab (56.36)	14.70a (80.14)
60-30-30 NPK + bio – fertilizer	6.20ab	2.62ab (58.78)	16.22a (98.77)
Mean of treated plants	6.544 (31.17)	2.558 (55.03)	16.198 (98.51)

Means in a column followed by the same letter are not significantly different at $P>0.05$ Figures in () are % increase over control.

Pot experiment is limited environment/ space for root growth, water and nutrient uptake. To further assess better response of green onion to bio – fertilizer inoculation field

experiments in two types of soil were set up, namely ; Maligaya clay in central Luzon State University, Nueva Ecija and, Maahas Clay in BIOTECH demo Site, University Philippines Los Baños, College Laguna.

Table 3 shows that the oven dry weight or dry matter yield of green onion roots when raised under pots would require only 60-30-30 NPK or bio - fertilizer inoculation alone. The trend is also exhibited in N-content of roots. The roots of bio - fertilizer inoculated plants had significantly higher N-uptake than the other treatments. This implies that inoculated plants have synthesized and/or absorbed N from the atmosphere and uptake by the inoculated plants is even better than the chemically fertilized plants.

Table 3. Root biomass, N-content and N-uptake of onion roots grown in potted Maligaya clay under screen cage.

TREATMENTS	FRESH WEIGHT (g/plant)	NO. OF TILLERS/ PLANT	PLANT HEIGHT (cm)
Control	3.28c	1.68d	5.50e
Bio – fertilizer	4.23b(28.96)	2.79a	11.83a (115.09)
120-60-60 NPK	4.18b (27.43)	2.26b	9.44c (71.63)
60-30-30 NPK	4.30a (39.09)	2.21b	10.44b (89.81)
120-60-60 NPK + bio – fertilizer	4.05b (23.47)	1.82c	7.37d (34.00)
60-30-30 NPK + bio – fertilizer	4.15b(26.52)	1.91c	7.92d (44.00)
	5.89		5.33

Means in a column followed by the same letter are not significantly different at $P>0.05$

Figures in () are % increase over control.

The potential of bio - fertilizer as either supplement or substitute for inorganic fertilizer requirement for green onion was noted as shown by the comparable results obtained from bio - fertilizer inoculation alone.

2. Soil Analysis

The soil used in this preliminary trial using pot experiment was collected from Central Luzon State University experimental farm. The soil is slightly acidic with pH 5.9, 2.095 organic matter and total nitrogen of 0.085, available P 7 ppm and has sufficient K of 0.31 m.e./100g. After harvesting, except for soil phosphorus in the bio - fertilizer inoculated and the control pots, slight change or decrease in total N and exchangeable K were observed. The final available P in the control pots was 2 ppm and only 1.5 ppm in the bio - fertilizer inoculated pots. The increase in N & K of fully fertilized pots and half-fertilized +bio - fertilizer could be due to the residuals in the soil, because of NPK fertilizer application and the short growing period of the test plant at harvest. These are the portions of the elements that were not utilized by the green onion. It is obvious from the figures that the control plants have used up some of the available P from the soil and the bio - fertilizer inoculated plants had utilized almost all of the soil P. The P may have been used in nitrogen fixation. It is noted that bio - fertilizer inoculated plants have the most roots N-uptake in spite of no fertilizer application.

Table 4. Pre-and post soil analyses of Maligaya clay used in the pot experiment

TREATMENT	Ph		OM(%)		N(%)		P (ppm)		K(m.e/100g)	
	Initial	Final	Initial	Final	Initial	Final	Initial	Final	Initial	Final
Control	5.9	6.67a	2.09	2.03d	0.08	0.10a	7	2.0d	0.31	0.71d
Bio – fertilizer	5.9	6.27b	2.09	2.23d	0.08	0.08b	7	1.5d	0.31	0.60c
120-60-60NPK	5.9	5.75c	2.09	2.33a	0.08	0.11a	7	28.75c	0.31	0.92c
60-60-30 NPK	5.9	5.45d	2.09	2.19c	0.08	0.11a	7	31.75b	0.31	1.04a
120-60-60 NPK + bio – fertilizer	5.9	5.55c	2.09	1.96e	0.08	0.11a	7	28.50c	0.31	0.94bc
60-60-30 NPK + bio – fertilizer	5.9	5.72	2.09	2.03d	0.08	0.11a	7	36.0a	0.31	0.97b
C.V. (%)	2.44		0.73		11.17		5.98		2.47	

Means in a column followed by the same letter are not significantly different at P>0.05.



Fig. 1: View of whole pot experiment. Note that pots were arranged for better comparison of treatments.



Fig. 2: Comparative morphological difference of spring onion as affected by bio - fertilizer inoculation and sole fertilizer application.



Fig. 3: Plant sample taken from pot experiment. Note: morphological differences of test plants due to treatments.

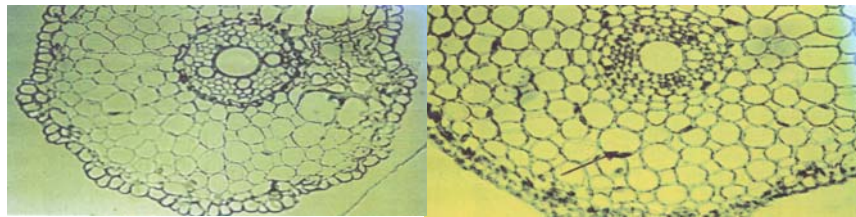

Fig. 4: Light photomicrograph of x-section of green onion roots grown in Maligaya clay showing apparent bacterial colonization in the bio - fertilizer inoculated roots. Note presence of bacteria on epidermal and in the cortical layer (arrow). Pot experiment.

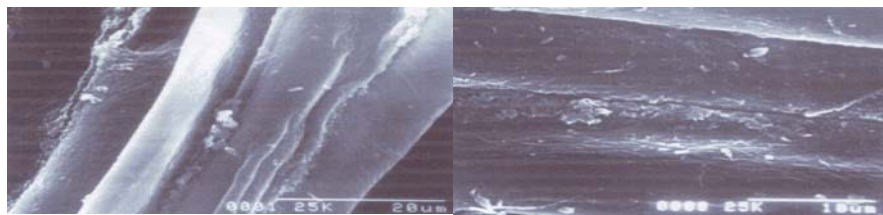

Fig. 5: Comparative adsorption of bacteria on root surfaces of onion grown in pots. Note: presence of numerous bacterial cells on surfaces of inoculated roots especially near loosen epidermal layer.

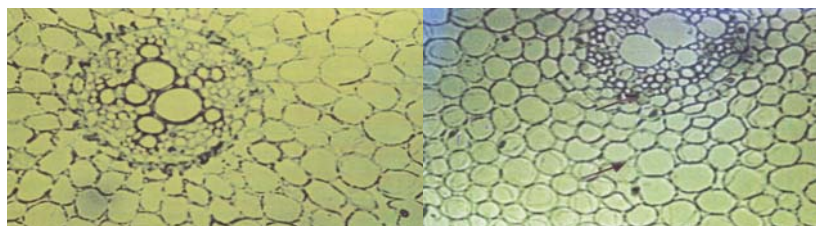

Fig. 6: Comparative apparent bacterial colonization of onion roots as seen in cross-section of roots as seen under the high power objective of the research microscope. Note: presence of bacteria on the cortical layer (arrow). Central Luzon State University Experiment.

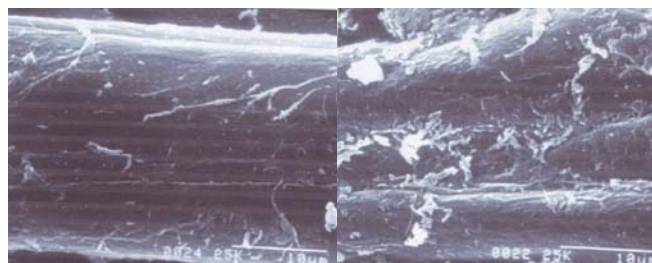

Fig. 7: Comparative adsorption of bacteria on root surfaces of onion grown in Maligaya soils, Central Luzon State University Experimental Station. Note: presence of numerous bacterial cells on surfaces of inoculated roots.

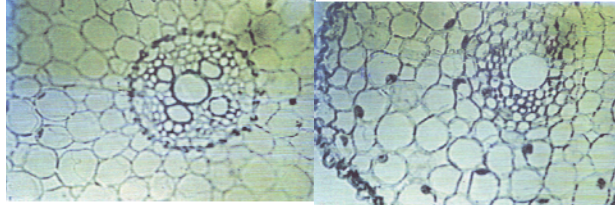

Fig. 8: Comparative apparent bacterial colonization of onion roots grown in Lipa clay loam grown under field condition (BIOTECH site) apparent presence of bacteria on the cortical layer (arrow).

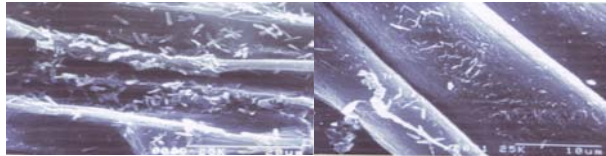

Fig. 9: Comparative adsorption of bacteria on root surfaces of onion grown in Lipa clay loam (BIOTECH site). Note: presence of numerous bacterial cells on root surface of inoculated roots especially near slough off epidermal layer.

CONCLUSIONS

In the nursery test, fresh weight at harvest was improved by all the treatments with a mean increase of 134.40% over the control plants. The mean fresh weight of all treatment was 20.51 g/plant while the control had only 8.75 g/plant. The fresh weight of plants that received bio - fertilizer alone was statistically the same as that of the fully fertilized but the plants were fertilized with $\frac{1}{2}$ FRR + bio - fertilizer yielded 149.71% increase over the control. The results from the pot experiment suggest that green onion can be grown in pots with minimum expense through inoculation with bio - fertilizer or in combination with only $\frac{1}{2}$ of the recommended fertilize dose. All the treatments significantly increased shoot N-uptake by 98.51% relative to the control.

ACKNOWLEDGEMENT

The author acknowledges FAPE-CHED for granting him a three-year scholarship grant. The DA-Bar , NCRP and SKPSC for dissertation assistance.

REFERENCES

- Barber et al 1976. Acetylene reduction (nitrogen fixation) associated with corn with *Spirillum*. *App. Env. Micro.* 32:103-113.
- Bashan et al 1990. *Applied and Environmental Microbiology*.
- Bautista 2000 *Bulbcrops Database*. Philippine Council for Agriculture, Forestry and Natural Resources Research and Development (PCARRD), Los Baños, Laguna.

- BIO-N Brochure – Nitrogen Supplement to Rice and Corn. A joint Venture Project of the University of the Philippines Los Baños, National Institute of Molecular Biology and Biotechnology and Livelihood Resource Center.
- Bulow & Dobereiner 1975. Potential for nitrogen fixation in maize genotypes in Brazil. PNAS (USA) 72:2389-2393.
- Garcia 2001. Development of BIO-N on Selected Crops (Biotech Core Project). Annual Report (January-October 2001). National Institute of Molecular Biology and
- Garcia et al 1977. Development of BIO-N for High Value Crops Annual Report (January-December 2002). National Institute of Molecular Biology and Biotechnology, UPLB, College of Laguna.
- Okon et al 1977. Methods of Growing *S. lipoferum* and for counting it in pure culture and in association with plants. App. Env. Micro. 33:85.
- Okon & Gonzales 1994. Agronomic applications of *Azospirillum*: An evaluation of 20 years Worldwide Field Inoculation In: Soil Bio..Biochem.26:12:1591-1601 Elsevier Science Ltd. Great Britain.
- Pornincula et al 2002. Socio-economic and Agro-ecological Characterization of Onion Production Environment in Central Luzon. Unpublished Progress Report. August 2001-August 2002. Research Office.CLSU, Muñoz, Nueva Ecija.
- Simbulan 1984. Variation in biochemical and morphologic characters, adsorption and nitrogenase activity of diazotrophs from upland rice (*Oryza sativa* L. ri-5) and talahib (*Saccharum spontaneum* L.) roots. Unpublished MS Thesis, University of the Philippines Los Baños.p.1.
- Shamsuddin et al. *Azospirillum* as a Bioenhancer and Biofertilizer for Banana and Oil Palm Seedlings.
- Sloger & Owens 1976. Nitrogen Fixation by a temperate corn – *Spirillum* association. In: International Symposium on Nitrogen Fixation, Salamanca.
- The Medium Term Development Plan. Department of Agriculture (MTDP-DA).

CHARACTERIZATION AND EVALUATION OF MICROFLORA BACTERIA ON VARIOUS PLANTATION SOILS AGAINST *Phytophthora capsici* OF BLACK PEPPER (*Piper nigrum* L.)

Awang Ahmad Sallehin Awang Husaini

Linda Nirwana Caroline, Samuel Lihan, Hairul Azman Roslan, Mohd Hasnain Hussain
Faculty of Resource Science and Technology
Universiti Malaysia Sarawak, MALAYSIA
hhasnain@frst.unimas.my

ABSTRACT

The purpose of this research study was to isolate, identify and evaluate the microfloral bacteria on different type of plantation soils against *Phytophthora capsici* of the black pepper (*Piper nigrum* L.). The screening of the antagonistic bacterial isolates against *P. capsici* was done by employing dual plate method. Three antagonistic bacteria, named as UMAS P1, UMAS P10 and UMAS P11 were successfully isolated. All of the isolates were characterized based on its colony morphology, gram staining, production of diffusible and volatile antibiotics and the microscopic observation on the abnormalities toward hyphae morphology of *P. capsici*. The molecular identification was conducted using 16S rDNA primers, and PCR products of 1500 bp in molecular weight of sizes were obtained and sequenced. Isolate of UMAS P10 and isolate of UMAS P11 were identified as *Burkholderia unamae* and *Enterobacter cloacae*, respectively. However, isolate, UMAS P1 could not be identified. The result of the study showed that *B. unamae* (UMAS P10) is the most effective antagonistic strain than other two antagonistic bacterial strains.

Keywords: Biocontrol, *Phytophthora capsici*, *Piper nigrum* L., 16S rDNA

INTRODUCTION

The foot rot disease of black pepper (*Piper nigrum* L.) caused by *Phytophthora capsici* is a common disease in many countries including Malaysia. It is a soil borne pathogen and attacks all parts and grows stages of the black pepper (Manohara *et al.*, 2004). The disease has been found in major black pepper plantation in Malaysia such as Sarawak.

The management of this disease usually relies on the chemical such as fungicides which are very toxic to human and environment, costly and labor intensive. Examples of the chemical used are metalaxyl, bordeaux and copper oxychloride (Dinu *et al.*, 2007). Since, chemical method in agricultural practices is hazardous to environment and mankind, it is important to find other measures to develop the non-chemical alternative methods to control the growth of *P. capsici*. One of the measures is by biological control method.

Biological control method refer to the utilization of introduced or resident living organisms, other than the disease resistant host plants, to suppress the activities and populations of one or more plant pathogens (Pal & Gardener, 2006). The organisms that suppress the pest or pathogen are referred to as Biological Control Agent or known as BCA (Heydari & Pessarakli, 2010). Nevertheless, biological control may not able to completely eliminate the pathogen (Kamil *et al.*, 2004). Biological control methods with the antagonistic microorganism have been introduced for a better environmental management, harmless to human and cost effective since their application not only inhibiting plant pathogen but at the same time enhances plant growth as well. However, they cannot work as rapid as the chemical methods and may provide only a partial level of control (Kamil *et al.*, 2004).

Root-free soil usually rich with bacteria species. In a gram of soil, there are billions of bacteria. Most of the bacteria lived ten centimeter beneath the soils surface where the organic matter presence (Whipps, J., 2001). Therefore, in this present study, we reported on the successful isolation and characterization of the antagonistic floral bacteria from various plantation soils which are potential to use and apply as biological control agent against *P. capsici*.in developing green technology for promoting sustainable agricultural practices.

MATERIALS AND METHODS

P. capsici obtained from the Malaysian Pepper Board, Sarawak was cultured on Potato Dextrose Agar (PDA) and stored at the 4°C. The plantation soil samples were collected from three different plantations sites viz black pepper plantation, palm oil plantation and pineapple plantation. The bacterial isolates were isolated through serial dilution method based on Noveriza and Quimio (2004). The petri dishes were incubated at 37°C for overnight and were further subcultured onto the fresh nutrient agar for several times in order to obtain the pure isolates.

The successfully obtained pure isolates were screened for antagonism against *P. capsici* by dual plate assay method (Kerr, 1999; Akgul & Mirik, 2008). The antagonistic activity was evaluated by measuring the radial growth of *P. capsici* in the presence of the antagonist bacterial isolates (Shashidhara *et al.* 2008). One 6-mm diameter of *P. capsici* agar plug was placed at the centre of PDA medium in a Petri dish with 9 cm diameter. Bacterial isolate was streaked on PDA medium with a distance of 2.5 cm between *P. capsici* agar plug and bacterial isolate. Plates were incubated for 7 days at 26 ± 2°C. Each treatment was run in triplicate. The percentage of radial inhibition growth was calculated as follows:

$$\% \text{ inhibition} = [1 - (\text{Fungal growth} / \text{Control growth})] \times 100\%.$$

Pure isolates of potential antagonistic bacterial were further identified and morphologically characterized by comparing the colony morphology such as shape, color and surface. The gram staining was conducted as well according to the standard method.

DNA of the potential antagonistic bacterial isolated was extracted (Zheng et al., 2006). Complete sequencing was done by the amplification of 16S rDNA with bacterial universal primers 27F and 1492R (Ludwig & Schleifer, 1994). The sequences were then analyzed using the BLAST program and the bacterial isolates identification were established according to the closest sequences match.

The production of diffusible and volatile antibiotics was done according to the method as described by Ann, (2012). Each experiment consists of a single bacterial isolate and done in triplicates. Results were expressed as means of % inhibition \pm S.D. of growth of pathogen in the presence and absence of any antagonist bacterial isolate (Ann, 2012).

RESULTS AND DISCUSSION

Thirteen colonies of morphologically different bacterial isolates were successfully isolated from the soil samples from three different types of plantation soils. Dual plate method was conducted in order to screen the antagonistic bacterial isolates based on the mycelial growth inhibition of the *P. capsici*. Among the thirteen floral bacteria isolates, only three isolates showed the inhibition of the radial growth of *P. capsici*. Table 1 summarized the antagonistic bacteria activity against *P. capsici*.

Table 1. Antagonistic bacterial isolates against *P. capsici* by using dual culture method.

Isolates	% of inhibition
P1	36.89
P10	47.65
P11	32.13

Through the primary screening of antagonistic bacteria via dual culture assay, the present study identified that bacterial isolate P10 as the most effective and promising bacterial isolate that was able to suppress the radial growth of *P. capsici* followed by isolates P1 and P11. It was recorded that inhibition against *P. capsici* in isolate P10 was 47.7%. Meanwhile, inhibition against *P. capsici* in isolates P1 and P11 were 36.9% and 32.1% respectively. The data obtained were based on the percentage of inhibition of the radial growth of *P. capsici* in the presence of any of the bacterial isolates.

The three isolated antagonistic bacteria were further screened based on their inhibition activity toward *P. capsici*. The cell and colony morphology of each of the potential antagonistic bacteria were observed (Table 2).

Table 2. Morphological characteristics of the isolated antagonistic bacteria.

Isolates	Gram stain	Colony morphology
P1	Rod shaped, gram -ve	Purple colony, smooth
P10	Rod shaped, gram -ve	Dark creamy colony, smooth
P11	Rod shaped, gram -ve	Creamy colony, smooth

In this study, microfloral bacteria in the plantation soils was evaluated for their antagonism against *P. capsici*, the causative agent of foot rot disease in black pepper (*Piper nigrum* L.). The screening experiments resulted in the discovery of three potential antagonistic bacteria which were coded as isolate P1, P10 and P11. Isolate P1 was not successfully molecularly identified whereas isolate P10 belong to genus *Burkholderia* and isolate P11 belong to the genus of *Enterobacter*.

The production of diffusible and volatile antibiotic also been tested since it was found to be the common characteristics among the potential antagonistic bacterial strains (Tariq et al., 2010). The two antibiotic tests, diffusible and volatile were conducted to determine which mechanism involved in the inhibition. During the test on the production of diffusible antibiotics, the growths of the *P. capsici* were significantly inhibited by the antagonistic bacterial isolates. The entire antagonist bacteria were shown to be significantly different as compared to the control. The antagonistic bacteria, P10 show the highest percentage of inhibitory effect on the growth of *P. capsici* as compared to P1 and P11 (Figure 1).

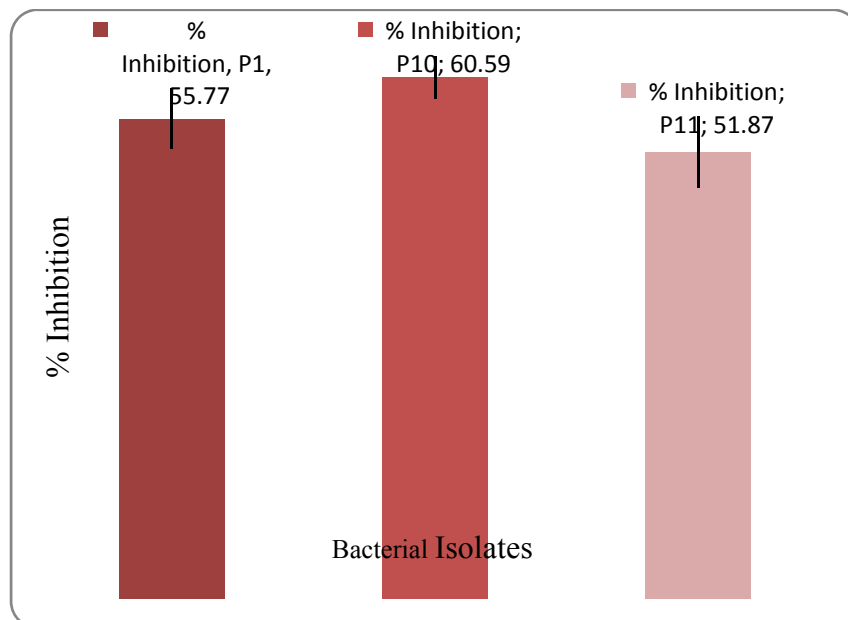

Fig.1. The effect of diffusible antibiotic of bacterial isolates on the radial growth of *P. capsici*. Each bar represents the mean of three independence experiments \pm standard deviation.

During the production of volatile antibiotics, the effect of the antagonist bacteria toward *P. capsici* was relatively the same as the results obtained from the diffusible antibiotics experiments. Each of the antagonist bacteria inhibited *P. capsici* at various levels. Antagonistic bacterial isolate P10 shows the best inhibitory effect again as compared to other bacterial isolates, P1 and P11 (Figure 2).

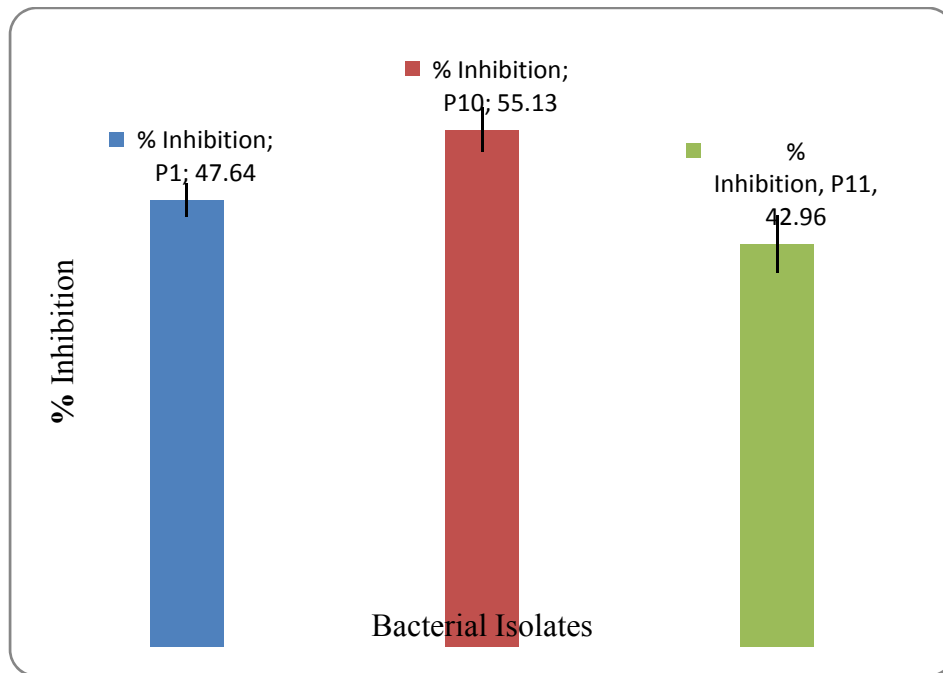

Fig. 2. The effect of volatile antibiotic of bacterial isolates on the radial growth of *P. capsici*. Each bar represents the mean of three independence experiment \pm standard deviation.

The best potential antagonistic strain P10 is identified as *Burkholderia* sp and in molecular basis has close similarities with *Burkholderia unamae*. *Burkholderia unamae* is known as a nitrogen-fixing rhizosperic and endophytic species which has the ability to fix nitrogen into ammonia by using the benzoate as carbon source (Caballero-Melado *et al.*, 2004). Apart from that, *Burkholderia* sp. has potency to promote plant growth as it produces phytohormones and growth enhancement in the form of volatile compounds (Fuentes-Ramirez & Caballero-Mellado, 2005). It has also been detected to produce several antibiotics such as pirrolnitrine and pioluteorine which have a wide antibiotics spectrum (Ezziyani *et al.*, 2009).

Isolate, P11 was identified as *Enterobacter* sp and in molecular basis has close similarities with *Enterobacter cloacae*. According to the study conduct by Costa and Loper (1994), *E. cloacae* also act as biological agent toward *Phythium ultimum*. The strain of *E. cloacae* produces an unidentified catechol which is a type of siderophores that can suppress the growth of *P. ultimum*. Siderophores are low molecular weight of ferric ion specific ligands produced by organisms as iron-scavenging agents when the available forms of iron are limited (Neilands, 1995). It is one of the chitinolytic bacteria which can lyse chitin (Chernin *et al.*, 1995). Chitin is the major component of the fungal cell wall which consist of insoluble linear polymer of N-acetylglucosamine (Glc-Nac) in a β -1,4 linkage (Chernin *et al.*, 1995). Based on the study conducted by Chae *et al.* (2006) showed that the increasing in the microbial activities in rhizosphere with chitin compost amendment can protect the plant from *P. capsici* infection.

CONCLUSION

Three of potential antagonistic bacterial strains which were successfully isolated showed significant antagonism activity towards *P. capsici*. Out of the three bacterial isolates, isolates P10 which was identified as *Burkholderia unamae* is the most efficient antagonist isolate. All three of the potential antagonistic bacteria strain can be used and applied as biological control agents to suppress the infection of *P.capsici* of the black pepper (*Piper nigrum* L.)

ACKNOWLEDGEMENT

This research project was financially supported by Universiti Malaysia Sarawak and the Ministry of Higher Education Malaysia (MoE) under the Exploratory Research Grant Scheme, ERGS/01(02)/852/2012(4).

REFERENCES

- Akgul, D.S. & Mirik, M. (2008). Biocontrol of *Phytophthora capsici* on pepper plants by *Bacillus megaterium* strains. *Journal of Plant Pathology*, 29-34.
- Ann, Y. C. (2012). Rhizobacteria of pepper (*Piper nigrum*) and their antifungal activities. *African Journal of Microbiology Research*, 6(19), 4185-4193.
- Caballero-Melado, J., Mrtinez-Aquilar, L., Paredes-Valdez, G. & Estrada-de los Santos, P. (2004). *Burkholderia unamae* sp. nov., An N₂-fixing rhizosperic and endophytic species. *International Journal of Systematic and Evolutionary Microbiology*, 54, 1165-1172.
- Chernin, L., Ismailov, Z., Haran, S. & Chet, I. (1995). Chitinolytic Enterobacter agglomerans antagonistic to fungal plant pathogens. *Applied and Environmental Microbiology*, 61(5), 1720-1726.
- Costa, H.M. & Loper, J.E. (1994). Characterization of siderophore production by the biological control agent Enterobacter cloacae. *Molecular Plant-microbe Interactions*, 7(4), 440-448.
- Dinu, A., Kumar, A., Aravind, R. & Eapen, S.J. (2007). An improved method for selection of antagonistic bacteria against *Phytophthora capsici* Leonian infections in black pepper (*Piper nigrum* L.). *Journal of Spices and Aromatic Crops*, 16(1), 1-7.
- Ezziyyani, M., Requena, M.E., Egea-Gilabert, C., Requena, A.M. & Candela, M.E. (2009). Biological control of *Phytophthora capsici* root rot of pepper (*Capsicum annum*) using *Burkholderia cepacia* and *Trichoderma harzianum*. *Journal of Applied Biosciences*, 13, 745-754.
- Fuentes-Ramirez, L. & Caballero-Mellado, J. (2005). Bacterial biofertilizers. *PGPR: Biocontrol and Biofertilization*, 143-172.
- Heydari, A. & Pessarakli, M. (2010). A Review on biological control of fungal plant pathogens using microbial antagonists. *Journal of Biological Sciences*, 10(4), 273-290.
- Kamil, M.A.J., Sharifuddin, S. & Bong, C.L. (2004). Biological control of black pod disease of cocoa in Malaysia. *Managing Phytophthora*, 174-177.
- Kerr, J. (1999). Bacterial inhibition of fungal growth and pathogenicity. *Microbial Ecology in Health and Disease*, 12, 129-142.

- Ludwig W, Schleifer KH (1994). Bacterial phylogeny based on 16S and 23S rRNA sequence analysis. *FEMS Microbiol. Rev.*, 15, 155-173.
- Neilands, J. (1995). Siderophores: Structure and function of microbial iron transport compounds. *Journal of Biochemical Chemistry*, 270(45), 26723-26726.
- Noveriza, R. & Quimio, T.H. (2004). Soil mycoflora of black pepper rhizosphere in the Philippines and their in vitro antagonism against *Phytophthora capsici*. *Indonesian Journal of Agricultural Science*, 5(1), 1-10.
- Pal, K.K. & Gardener, B.M. (2006). Biological control of plant pathogens. *The Plant Health Instructor*, 1-25.
- Shashidhara, S. (2007). Studies on Foot Rot of Black Pepper Caused by *Phytophthora capsici* Leonian. *M.Sc Thesis*.
- Tariq, M., Yasmin, S. & Hafeez, F. Y. (2010). Biological control of potato black scurf by rhizosphere associated bacteria. *Brazilian Journal of Microbiology*, 41, 439-451.
- Whipps, J. (2001). Microbial interactions and biocontrol in the rhizosphere. *Experimental Biology*, 52, 487-511.
- Zheng W, Quan CS, Piao YZ (2006). A speedy extraction method for bacterial chromosomal DNA.

HETEROLOGOUS EXPRESSION OF XYLANASE GENE FROM *KLEBSIELLA PNEUMONIAE* IN *E. COLI* BL21 (DE3) FOR POTENTIAL USE IN GREEN TECHNOLOGY

Suhaila Zainol, Nikson Fatt Ming Chong, Awang Ahmad Sallehin Awang Husaini,
Faculty of Resource Science and Technology University Malaysia Sarawak

hasnain@frst.unimas.my

ABSTRACT

A xylanolytic bacterium was isolated from sago plantation humus. Isolation and characterization of xylanase DNA sequence showed a total length of 642 bp. The full length xylanase gene was cloned in pSTAG vector and expressed in *E. coli* BL21 (DE3). *In silico* characterization determines the recombinant xylanase has a molecular weight of 23.9 kDa. The activity of crude recombinant xylanase was 2.015 U/mL, which was higher than the crude native xylanase activity that was only 0.642 U/mL at maximum. Staining of the birchwood xylan agar plate with Congo red showed a clearing zone around *E. coli* BL21 (DE3) that has positive recombinant xylanase even without the addition of IPTG, implying leaky expression had occurred. Further analysis showed the existence of two forms of the xylanase. These xylanases were enzymes with the size of 25kDa that accumulates in the cell, and the other as a 20kDa mature extracellular xylanase.

Key Words: *Klebsiella pneumoniae*, heterologous expression, cloning, recombinant xylanase

INTRODUCTION

Xylan consist of β -1,4-linked xylopyranosyl residues. It is the second most abundant polysaccharide and an important component that makes up the plant cell wall. Due to the heterogeneity and complexity of xylan structure, the complete hydrolysis of xylan is carried out by a xylanolytic enzyme system such as endo-1,4- β -D-xylanase (EC 3.2.1.8) (Kuhad & Singh, 2007). From a biotechnology perspective, xylanase is an important enzyme since its thermal stability makes it suitable in a number of industrial applications including in the green-agro industry. An example of the application of xylanase is in the paper and pulp industry where it is used in bio-bleaching, instead of using chemicals. The xylanase gene was isolated from xylanolytic *Klebsiella pneumoniae*, a bacterium that had been locally isolated from soil from a sago plantation by Hussain *et al.* (2011). So far, there are no research publications that described the isolation of any xylanase gene from *K. pneumoniae*.

MATERIALS AND METHODS

A. Xylanase Gene Amplification and Subcloning.

The primers were designed based on the isolated xylanase gene from *K. pneumoniae* by Hussain *et al.* (2011). PCR amplification was performed using *Pfu* DNA polymerase under the following condition: 94°C for 3 min, then 30 cycles of 94°C for 45 s, 52°C for 1 min, and 72°C for 2 min for each cycle, and a final 72°C for 5 min. The PCR product matching the predicted size was purified using GF-1 PCR Clean Up Kit (Vivantis). The xylanase PCR product was digested using *Bam*H1 and *Eco*R1 restriction enzymes. Positive clones harboring recombinant pSTAG plasmid were selected using PCR and sent for DNA sequencing.

B. Confirmation Of Xylanase Activity Through Congo Red Agar Staining

M9 minimal agar containing ampicillin were used to grow the *E. coli* BL21 (DE3). After incubation at 37°C overnight, the colonies were induced with a drop of 0.4 mM IPTG. Replicate plates were also prepared, but IPTG was not added to the replicate plates. The plates were incubated overnight. The following day, all the plates were stained with 1% Congo red solution and destained by washing with 1 M NaCl.

C. Bioinformatics Analysis of Xylanase Gene

Translation of DNA sequence to amino acid sequence was performed using ExPASy Bioinformatics Resource Portal (<http://expasy.org/>). Pairwise alignment was performed by using ClustalW2 (<http://www.ebi.ac.uk/Tools/msa/clustalw2/>). *In-silico* characterization for molecular weight and isoelectric point (pI) was predicted using ExPASy Bioinformatics Resource Portal (<http://expasy.org/>),

D. Crude Recombinant Enzyme Activity

The activity of crude recombinant xylanase enzyme using the soluble protein fraction was determined using Bicinchoninic Acid (BCA) assay, which was carried out based on the protocol described by Hussain *et al.* (2003). One unit of xylanase activity was defined as the amount of enzyme that released 1 µmol of reducing sugar per min under the assay condition.

RESULTS AND DISCUSSION

A. Xylanase Activity on Congo Red

Results of the Congo red staining on the half media (R) shows a clearing zone on the medium around *E. coli* BL21 (DE3) with positive recombinant pSTAG plasmid for both induced and uninduced cultures, while the other half media (VE) shows the absence of any clearing zone around *E. coli* BL21 (DE3) with empty pSTAG plasmid (Fig.1).

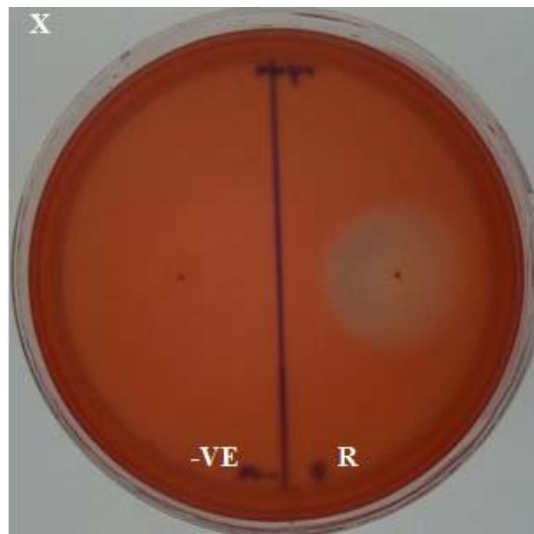

Figure 1: 1% Congo red staining.--VE represents recombinant *E. coli* BL21 (DE3) with empty pSTAG plasmid while R represents *E. coli* BL21 (DE3) with positive recombinant pSTAG plasmid.

According to Hussain *et al.* (2011), *in-silico* characterization of the native xylanase from the *K. pneumoniae* showed 99.5% identical to the isolated xylanase from the *B. subtilis* isolated by Jalal *et al.* (2009).

B. Insoluble Xylanase Accumulates In Cells, Soluble Xylanase Is Secreted Into Media

Analysis of total cell protein extracts showed that the molecular weight of crude recombinant xylanase matched the expected molecular weight of 25kDa predicted from *in-silico* characterization (Fig. 2). Expression without glucose in the media showed the “fattest” protein band, meaning a lot of protein was produced. Expression with glucose showed good results as well. As expected, both uninduced recombinant pSTAG plasmid with xylanase insertion and induced empty pSTAG plasmid that acted as a control did not show the presence of proteins band at the predicted molecular weight.

Analysis of the soluble fraction, insoluble fraction and supernatant fraction showed that the recombinant xylanase protein is secreted out of the cell as a 20 kDa protein, although the majority remains in the insoluble fraction as a 25kDa protein. This result supports the qualitative assay where xylanase was secreted out and degraded the xylan in the agar. The size of the secreted polypeptide is 20.37 kDa. This size corresponds to the predicted size of mature xylanase, determined from the amino acid peptide cleavage site to the termination codon. The second form is the 25kDa protein that accumulates in the cell, sometimes forming insoluble bodies, because the *E. coli* secretory system cannot cope with the large amounts of polypeptide which is produced by the expression mechanism under the control of the T7 promoter.

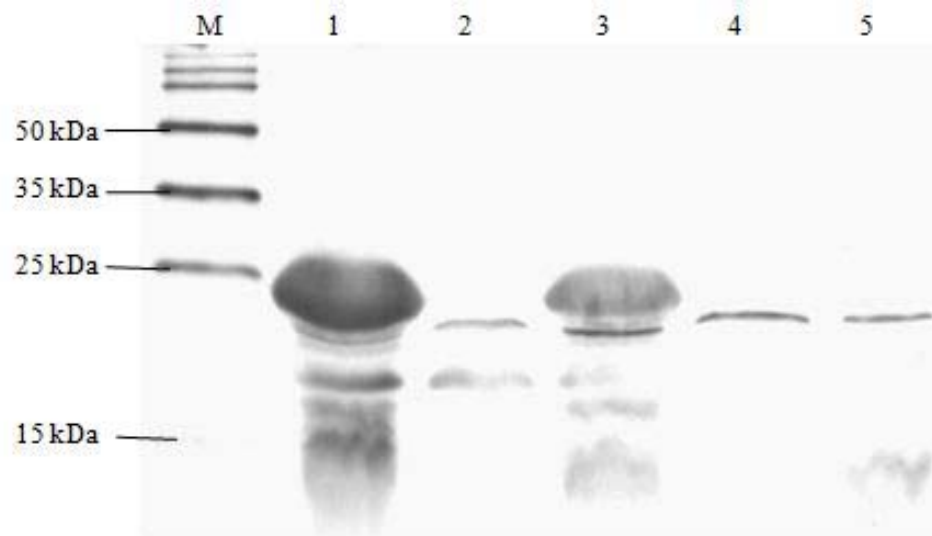

Figure 2: Western blot for xylanase gene expression (total cell protein).

Lane 1: induced recombinant pSTAG plasmid at 30°C, no glucose, lane 2: uninduced recombinant pSTAG plasmid at 30°C, no glucose, lane 3: induced recombinant pSTAG plasmid at 30°C, with 1% glucose, lane 4: uninduced recombinant pSTAG plasmid at 30°C, with 1% glucose and lane 5: induced empty pSTAG plasmid at 30°C, with 1% glucose. M is a Perfect Protein™ Western Markers (Novagen).

C. Crude Recombinant Xylanase Activity

The activity of crude recombinant xylanase is 2.015 U/mL, which is 3.139 times higher compared to the activity of crude native xylanase (0.642 U/mL at maximum) isolated by Hussain *et al.* (2011). Their recombinant xylanase showed high increase in activity compared to the activity by native xylanase. Thus the crude recombinant xylanase is expected having much higher activity after it is purified. Apart from that, the recombinant xylanase might have slightly different properties in term of pH and temperature stability compared to recombinant xylanase by Jalal *et al.* (2009), Helianti *et al.* (2008), and Lee *et al.* (2008). This is due to the slight difference in amino acid sequence.

CONCLUSIONS

Heterologous expression of xylanase gene from *Klebsiella pneumonia* has been successful. The activity of crude recombinant xylanase is 2.015 U/mL, which is 3.139 times higher than the activity of crude native xylanase. Furthermore, the xylanase exists in two forms, firstly a 25kDa protein that accumulates in the cells, and secondly, a mature xylanase which is secreted into the culture medium. Based on this work, there is a potential for producing xylanase at bigger scale, which can be used in various industrial application including green-technology.

ACKNOWLEDGEMENT

The authors would like to thank Universiti Malaysia Sarawak and CMS Agrotech for the funding of this research through grant L18403 F07 00 CMS AGROTECH.

REFERENCES

- Helianti, I, Nurhayati, N and Wahyuntari, B (2008) Cloning, sequencing, and expression of a β -1,4-endoxylanase gene from Indonesian *Bacillus licheniformis* strain I5 in *Escherichia coli*. *World Journal of Microbiology and Biotechnology* **24(8)**: 1273 – 1279
- Hussain, H, Mant, A, Seale, R, Zeeman, S, Hinchliffe, E, Edwards, A, Hylton, C, Bornemann, S, Smith, A M, Martin, C and Bustos, R (2003). Three isoforms of isoamylase contribute different catalytic properties for the debranching of potato glucans. *The Plant Cell* **15(1)**: 133 - 149
- Hussain, H and Martin, C (2009). Comparative analysis of primary and secondary structure for pea isoamylase isoforms predicts different catalytic properties against glucan substrates. *Starch/Stärke* **61(10)**: 570 – 577
- Hussain, M. H, Chong, N F M, Chan, C S W, Safarina, A and Husaini, A (2011). Xylanase gene from a locally isolated bacterium. *Malaysian Applied Biology* **40(1)**: 33 - 38
- Jalal, A, Rashid, N, Rasool, N and Akhtar, M (2009). Gene cloning and characterization of a xylanase from a newly isolated *Bacillus subtilis* strain R5. *Journal of Bioscience and Bioengineering* **107(4)**: 360 - 365
- Kuhad, R C and Singh, A (2007). *Lignocellulose biotechnology: Future prospects*. New Delhi: I.K. International Pub
- Lee, C, Kibblewhite-Accinelli, R, Smith, M, Wagschal, K, Orts, W and Wong, D (2008). Cloning of *Bacillus licheniformis* xylanase gene and characterization of recombinant enzyme. *Current Microbiology* **57(4)**: 301 – 305

GENETIC DIVERSITY OF FUSARIUM WILT RESISTANT POTATO PLANTLET PRODUCED BY GAMMA RAY IRRADIATION

Rahayu Sulistianingsih, Rina Sri Lestari and Ari Wijayani
Agrotechnology Departement, Faculty of Agriculture
Universitas Pembangunan Nasional "Veteran" Yogyakarta
Corresponding author : r.sulistya@gmail.com

ABSTRACT

Genetic diversity can be improved with the use of gamma ray irradiation to obtain plants that are resistant to the disease. Changes that occur can be analyzed at the beginning of plant growth using molecular analysis such as RAPD technique (Random Amplified Polymorphic DNA). This study aims to determine the genetic diversity produced by gamma rays irradiation and fusaric acid application in plantlets to increase potato resistance to Fusarium wilt. The study used four primers tested on four treatments i.e. not irradiated plantlets and not induced with the fusaric acid, irradiated with gamma rays irradiation 25 gray and not induced with fusaric acid, irradiated and induced with the fusaric acid 1 ppm, and irradiated and induced with the fusaric acid 3 ppm. The results showed a decrease of control diversity of genetics 0.20 to 0.30 in 25 gray irradiation treatment with application of fusaric acid 1 ppm. The use of the RAPD technique to determine genetic diversity resulted by gamma ray irradiation on the level of plantlets showed that theirradiation treatment caused mutations in all treatments tested. Plantlets of 25 gray irradiation and 1 ppm fusaric acid / 1 induction showed changes in DNA structure.

Keywords: *genetic diversity, potato plantlets, gamma rays and RAPD*

INTRODUCTION

Disease is one important limiting factor in potato cultivation. Potato tuber rot is the most serious disease of the diseases and pests that attack potato crops in Indonesia (Katayama & Teramoto, 1997; Zazali, 2004). Fusarium can lower potato production up to 90% of the total potato production in a very short time. Until now Fusarium sp. caused potato tuber rot disease is still a crucial issue and there are no varieties of potatoes which are completely resistant to the disease (Cholil, 1991). This disease also attacks potatoes in storage. Infection enters through wounds caused by nematodes or mechanical factors. Mutation techniques are recognized as an effective method to improve the genetic diversity of plants. Mutation breeding in particular irradiation is still a relatively new thing, different to crosses that aiming to gets a new crop that has superior properties by combining both properties of both parents. The irradiation can fill the lack of diversity contained in the hybridization byt enabling the new acquired heredity that is not owned by the parent plants (Harten, 1998; Kovalchuk et al., 2000).

Evaluation of genetic diversity can be done with markers of morphological, biochemical and molecular. Utilization of DNA as a molecular marker to Marker Assisted tool Selection (MAS) is more profitable than the selection on phenotypic (Ishak, 1998; Azzrai, 2005). Plant species diversity measurements can be done with genetic characters such as RFLP (Restriction Fragment Length Polymorphism), RAPD (Random Amplified Polymorphic DNA) and AFLP (Amplified Fragment Length Polymorphism). The use of RAPD is a PCR-based markers (*Polymerase Chain Reaction*) using nucleotide sequences as primers are common ways used to help determine the presence of mutations without having to look the phenotype (Hughes, 1996). Mutations that occur at the level of genomic DNA can be detected with molecular markers, the technique of *Random Amplified Polymorphic DNA* (RAPD), using various types of "arbitrary primer" (Ishak, 1998). The purpose of this study was to determine the mutations that occur in potato plantlets resulted by gamma ray irradiation to increase resistance to Fusarium wilt using RAPD technique.

MATERIALS AND METHODS

The study was conducted in the Laboratory of Genetics and Plant Breeding Faculty of Agriculture, Gadjah Mada University in Yogyakarta. Implementation was in June to August 2012, Potato plantlets produced by irradiated gamma rays that have been done using fusaric acid for resistance to Fusarium diseases. Leaves of potato plantlets for DNA were extracted by the CTAB method (Sulistianingsih, et al., 2012). PCR amplification reaction (Polymerase Chain Reaction) was performed using a Gene Amp PCR System 9700, aims at doubling sequence based primers used. Visualization of the results of PCR using the BioRad elektrophoresis 1.5% agarose gel 100 Volt, 400 amps and 45 minutes, soaked in a solution of EtBr for 25 min measurements were made with a trans-illuminator UVT-200

The method used is a laboratory method to four (4) treatments, namely: P0= plantlets were not irradiated and not treated with fusaric acid; P1= plantlets irradiated with 25 gray gamma radiation without fusaric acid induction; P2= plantlets irradiated with 25 gray gamma radiation with 1 ppm fusaric acid induction, and P3= plantlets irradiated with 25 gray gamma radiation with 3 ppm fusaric acid induction. Each treatment was replicated 3 times.

Observations were made by looking for bands of DNA in the agarose gel to electrophoresis of the primers outcome tested PCR. Data obtained were in scoring with evident (1) or not evident (0) bands of each individual in a specific size for each primer. From these data it will be seen the number and percentage of polymorphic loci. Value of genetic diversity (h) for each treatment was calculated based on Nei's gene diversity (1973), performed by Gen Alex 6 program (Peakall and Smouse 2006).

RESULTS AND DISCUSSION

Diversity is calculated based on allele frequencies (1 and 0) and the number of polymorphic loci, which showed genetic diversity within populations of plants

irradiated with Co-60 gamma rays. This causes the value of diversity in line with the value sufficient percentage of polymorphic loci, i.e. the higher the percentage of polymorphic loci the higher coefficient of variability that arises. Occurring polymorphism of RAPD analysis indicated the formation of individual DNA bands in one while the other individual bands were not formed at the same position or size. The primary polymorphism would indicate the level of genetic diversity. At all tested primer DNA bands were formed between 300 to 1800 bp. Figure 1 shows the results of electrophoregram for each treatment; the arrow indicates the addition of the band and the reduction of DNA bands that emerged in the treatment irradiated with gamma rays 25%.

Table 1: Primer (Production Operon Technologies) were used for screening resistance to Fusarium wilt fusaric acid at different doses

Primer	Nucleotide Sequence Bases
OPA20	GTTGCGATCC
OPB 15	GGAGGGTGTT
OPB 20	GGACCCTTAC

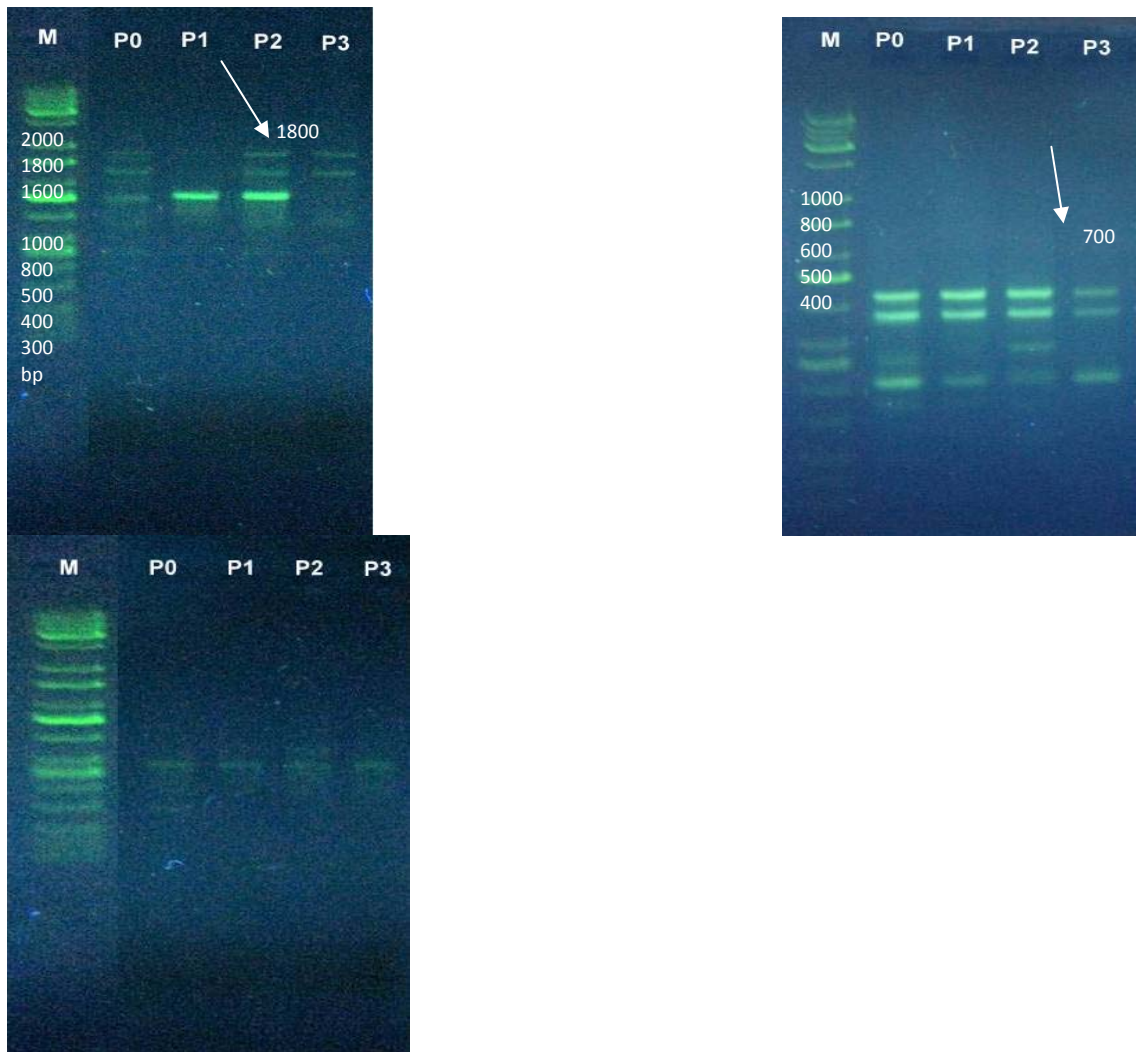

Figure 1. Electrophoregram of 25 gray gamma irradiated potato plantlets with fusaric acid induction at different doses.

Description: A: Primer OPA20 B. Primer OPB20 C. Primer OPB15 arrows indicate the addition and subtraction bands that are not present in control (P0). M = Mark. P0: plantlets were not irradiated and not treated with fusaric acid; P1 = plantlets were irradiated with 25 gray gamma radiation without fusaric acid induction; P2 = plantlets were irradiated with 25 gray gamma radiation and 1 ppm fusaric acid induction and P3 = plantlets were irradiated with 25 gray gamma radiation and 3 ppm fusaric acid induction.

Table 2 shows a decrease in genetic of diversity in gamma-irradiated plantlets 25 gray, from 0.231 in positive control (P0) to 0.124 at P3 (induced with 3 ppm/l fusaric acid). As well as the percentage of polymorphisms that occurred 52% in the positive control decreased to 28% at the treatment of induction with fusaric acid 3 ppm/l. It may have caused a change in the gene's ability to survive stress conditions induced by fusaric acid.

Table 2. Genetic diversity caused by gamma-ray irradiation 25 gray and fusaric acid induction as a resistance to *Fusarium* wilt

Pop		N	Na	Ne	I	H	uh	% polimorfism
P0	Mean	3.000	1.280	1.416	0.331	0.231	0.347	52.00%
	SE	0.000	0.169	0.082	0.065	0.045	0.068	
P1	Mean	3.000	1.080	1.256	0.204	0.142	0.213	32.00%
	SE	0.000	0.152	0.076	0.061	0.042	0.063	
P2	Mean	3.000	1.200	1.320	0.255	0.178	0.267	40.00%
	SE	0.000	0.153	0.080	0.064	0.044	0.067	
P3	Mean	3.000	0.960	1.224	0.178	0.124	0.187	28.00%
	SE	0.000	0.158	0.073	0.058	0.041	0.061	
Total	Mean	3.000	1.130	1.304	0.242	0.169	0.253	38.00%
	SE	0.000	0.079	0.039	0.031	0.022	0.033	5.29%

Description:

N = Number of alleles; Na = Number of different alleles, Ne = number of effective alleles, I = index shanon, h = genetic diversity; uh = Diversity is not biased and percentage polymorphic P0: plantlets were not irradiated and not treated with fusaric acid; P1: the plantlets in 25 gray gamma ray-irradiation without fusaric acid induction; P2: gamma-irradiated plantlets 25 gray and 1 ppm fusaric acid induction and P3: gamma ray-irradiated plantlets 25 gray and 3 ppm fusaric acid induction.

Table 3: Matrix of dissimilarity values in the population based on Nei's genetic diversity of potato plantlets irradiated with gamma rays and induced with fusaric acid for resistance to *Fusarium* wilt

P0	P1	P2	P3	
	0.000			P0
	0.128	0.000		P1
	0.133	0.019	0.000	P2
	0.111	0.026	0.032	0.000 P3

Description: P0: Positive control was not irradiated and not induced with fusaric acid
P1: gamma irradiated plantlets at 25 gray and not induced with fusaric acid
P2: gamma irradiated plantlets at 25 gray and induced with 1 ppm fusaric acid/l
P3: gamma irradiated planlet at 25 gray and induced with 3 ppm fusaric acid/l

Analysis of genetic dissimilarity ranged from 0.026 to 0.133 indicated a genetic change caused by gamma rays irradiation. Genetic value inequalities on positive control showed a higher rate i.e. 0.133 possibly due to somaclonal variation due to planting in-vitro.

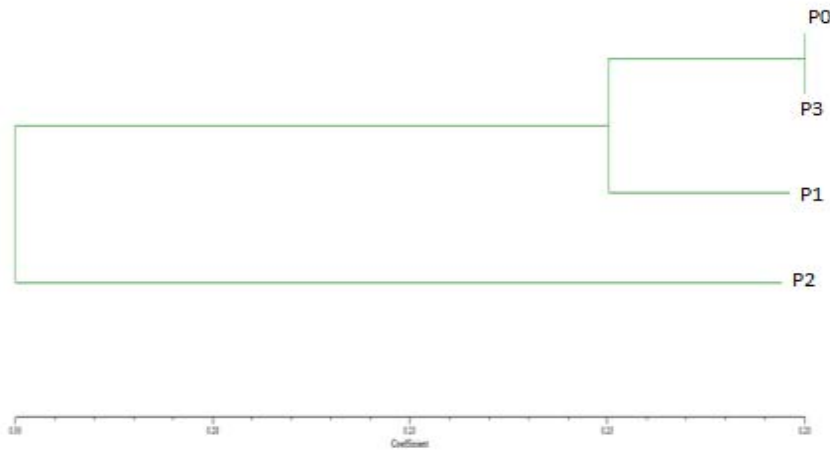

Figure 2: Dendrogram of genetic distance of potato plantlets irradiated with gamma ray and induced with fusaric acid by using different primer RAPD technique

Figure 2 shows genetic distance in populations of potato plantlets on various treatments. P0 and P3 have the same coefficient of genetic distance i.e. 0.20, while P1 of 0.23 genetic distance and the farthest change is P2 with coefficients 0.30. This indicates that irradiation gave rise to a very broad genetic variation, as well as the application of fusaric acid into the media of each sample showed a very high polymorphism based on Nei's Gene diversity analysis (Sulistianingsih *et al.*, 2012). Plants able to survive against fusaric acid stress can be said as fusarium attack resistant but is very little resistance genes that can be gained. This could be due to somaclonal variation. Somaclonal variation that occurred in tissue culture is the cumulative result of a genetic mutation in the explants and induced in vitro (Yunita, 2009). Somaclonal variation is a genetic alteration that is not caused by segregation or recombination of genes, as commonly occurs due to the cross, diversity induced by tissue culture. This diversity can arise due to a doubling in the chromosome (fusion, endomitosis), changes in chromosome number (tagging and non-disjunction), changes in chromosome structure, gene changes, and changes in the cytoplasm (Kumar and Mathur, 2004). In vitro selection is more efficient because the selection can be made in homogeneous conditions, where it takes relatively few, and the effectiveness of the high selection. Therefore, a combination of induction of somaclonal variation and in vitro selection technology is an effective alternative to produce individuals with a specific character (Kadir, 2007). The use of in vitro techniques will produce a variant of cell populations by selection on appropriate media. The intensity of selection can be strengthened and made more homogeneously. Tissue or plant cells can be selected in the selection of medium that will increase the frequency of variants with desired properties (Specht and Greaf 1996; Biswas *et al.*, 2002).

CONCLUSION

Within the present study it can be summarized as follows:

1. RAPD technique can be used to determine genetic diversity resulting from gamma ray irradiation at level of plantlets.
2. Gamma ray irradiation caused mutations in all treatments tested.
3. Plantlet of 25 gray of gamma rays irradiation and 1 ppm/l fusaric acid induction had changed stucture of DNA.

ACKNOWLEDGEMENTS

The author thank the Directorate General of Higher Education of Ministry of Education and Culture which provided research fund through scheme of Competitive National Strategic Research Grant in 2011.

REFERENCES

- Azrai, M. 2005. Pemanfaatan markah molekuler dalam Proses Seleksi Pemuliaan Tanaman. *J.Agro-Biogen* 1(1) 26-37
- Biswan,B., Chowdhury, A. Bhattacharya and B. Mandal., 2002. In-vitro Screening for Increasing drought toleran in Rice. *InVitro Cell, Dev. Biol.Plant.*38.p525-530.
- Harten, A.M van. 1998. *Mutation Breeding: Theory and Practical applications.* Cambridge University Press. p.1-35.
- Hughes, M.A. 1996. *Plant Molecular Genetic* First ed. Longman. United of Kingdom.p3
- Ishak. 1998. Identifikasi Keragaman DNA genom Mutan Padi Atomita-2 dan tetuanya menggunakan RAPD Marker. *Zuriat*, 9(2); 91-99
- Kadir, A., 2007. Induksi Variasi Somaklonal melalui induksi iradiasi sinar gamma dan seleksi in-vitro tanaman nilam toleran terhadap cekaman Kekeringan. Disertasi Sekolah Pasca Sarjana Institut Pertanian Bogor.
- Kovalchuk, I., Kovalchuk, O. And Hohn, B.,2000. Genome-wide variation of the somatic mutation frequency in transgenic plants. *The EMBO journal*, Vol. 19 (17) p.4431-4438.
- Kumar P.S. and V.I. Mathur, 2004. Chromosomal Unstability in Callus Culture of *Pisum sativum*. *Plant Cell. Tiss.Org.Cult.* 78.p267-271.
- Peakall R. and P.E. Smouse ,2006. Gen AlEx 6: Genetic Analysis in Excel. Population Genetic software for Teaching and Research. Australian Antional University, Canberra, Australia.. <http://www.anu.edu.au/BoZo/GenAlEx/>. Accessed in 03 January 2008.
- Specht, J.E. and G.I. Greaf. 1996. Limitation and Potential for Genetic Manipulation of Soybean. In. DPS Verma and RC Shoemaker(Eds) Soybean. Genetic. Molecular, Biology and Biotechnology. CAB. Intl. England.

- Sulistianingsih, R. A.Purwantoro, W. Mangoendidjojo dan E. Semiarti, 2012. Variasi Genetik Anggrek Alam *Phalaenopsis amabilis* Hasil Iradiasi Sinar Gamma. *Jurnal Ilmiah Aplikasi Isotop dan Radiasi* Vol8 (1) Juni 2012.
- Yunita, R., 2009. Pemanfaatan variasi somaklonal dan seleksi in-vitro dalam perakitan tanaman toleran cekaman abiotik. *J. Litbang Pertanian*. 28(4).p142-147.

NUTRIENT ANALYSIS OF PALM EMPTY FRUIT BUNCH, PALM FRUIT FIBERS AND SAWDUST AS MEDIA FOR WHITE OYSTER MUSHROOM CULTIVATION

Sulistiyanto. Y ¹⁾ Balfast, K ¹⁾ Usup, A ¹⁾

¹⁾ Agro technology study program, Faculty of Agriculture, University of Palangka Raya

Sulistiyanto_y@yahoo.co.uk

ABSTRACT

In Central Kalimantan, many oil palm factories were built and produce a lot of solid waste, such as, empty fruit bunches of oil palm, kernel, and palm fruit fibers. Many attempts made to utilize waste, such as, organic fertilizer, fuel factories, street paving. For this study, empty fruit bunches and palm fruit fibers used as the media for White Oyster Mushroom cultivation. This study aims to determine the mycelium growth, production of white oyster mushrooms, and the changes of nutrient content of the media after the white oyster mushroom cultivated. This study used Completely Randomized Design (CRD) single factor, consisted of three levels, namely: the first media is sawdust (M1), second media is empty fruit bunch (M2), and third media is fruit fiber (M3). Each treatment was repeated 9 times to obtain 27 units of the experiment. The results indicated that the sawdust media showed growth of mycelium and production of white oyster mushroom is the best, followed by the media of oil palm empty fruit bunch and the lowest is the palm fruit fiber media. The results also indicate a change in nutrient content of the three media. The sawdust media, decreased nutrient is N, K, Na, Ca, C, Mg, whereas P increased nutrients. Oil palm empty fruit bunch media, decreased nutrient are K, Na, Ca and C, while increased nutrients are N, P and Mg. Oil palm fruit fibers media, decreased nutrient is N, K, Na, Ca, and C, whereas the increased nutrient is P and Mg.

Keywords : *Mushroom Media, Nutrient Content, White Oyster Mushroom.*

INTRODUCTION

Oyster mushroom is a fungus that is quite popular in Central Kalimantan, also known as white fungus or white oyster mushrooms, oyster mushrooms availability in Central Kalimantan are generally produced from the forest and the number of farmers are still little so that the availability of oyster mushrooms can not be met continuously.

Oyster mushroom cultivation media can be used are logs, sawdust, waste from wood processing industry. In experiments, a wooden mushroom can be cultivated on other wood media, such as straw, cotton waste, paper waste as long as it contains cellulose. Now, the most commonly used media is sawdust, waste from the wood processing industry, although the sawdust should be added with other ingredients, such as rice bran, TSP, dolomite lime, and water (Agus et al., 2001).

The availability of palm oil waste is abundant in Central Kalimantan, can be used as mulch, organic fertilizer, and can also be used as an oyster mushroom growing media so it can increase the economic value of the waste, increasing employment opportunities for the people of Palangka Raya, primarily people who live surrounding factory. Similar statement have been said by Asi et al. , (2002) that Central Kalimantan has potential in agribusiness fungus development because it is supported by the availability of raw materials such as waste oil palm empty fruit bunches (TKKS) and wood sawdust .

Oil palm empty fruit bunches (TKKS) is one type of solid waste type generated from the palm oil industry, the number quite large, as almost equal to the total production of crude palm oil. The waste has not been used optimally. The largest component of TKKS (oil palm empty fruit bunches) is cellulose (40-60 %), in addition other components such as, hemicellulose smaller amount (20-30 %), and lignin (15-30 %) (Dekker cited Arofathullah, 2011). According to (Sudiyani cited Andayani, 2010) the largest component of TKKS is cellulose (41.3-46.5%), hemicellulose (25.3-33.8%), and lignin (27.6-32.5%). Meanwhile, according to (Darmoko cited Asi et al., 2002), palm empty fruit bunch and palm fruit fiber are generated waste from palm oil mills (PKS), both contain hemicellulose (67.88 %) , cellulose (38.76 %), lignin (22.23 %) and ash (6.59%).

MATERIALS AND METHODS

The research was conducted from December 2011 to August 2012 in the city of Palangka Raya Central Kalimantan province. Materials used were sawdust, oil palm empty fruit bunches, palm fruit fiber, bran, dolomite, gypsum, pipe ring, TSP fertilizer, seed oyster mushrooms F2, kerosene, water, plastic bag log, cotton, paper, rubber bands, 90 % alcohol, while the tool were used sterilized bag log, needle ose, spade, machete.

The research method used was a completely randomized design (CRD) with a single factor that is mushroom growing media, such as, sawdust, oil palm empty fruit bunches and palm fruit fibers. Each media repeated 9 times so there are 27 units bag log.

To determine the effect of different growing media, the observations of growth and production of white oyster mushrooms were statistically tested using the F test (analysis of variance) at the level of 5 % and 1 % , if the inter media show the real effect it will proceed honestly significant difference test (HSD) at the level of 5 % . If there is missing data, to make it easier to analyze, the data will be presented in the form of tabulations and graphs.

RESULTS AND DISCUSSION

A. Growth of Mycelium of White Oyster Mushroom

Based on the result of the data analysis of variance showed that there is not significantly different among the three (M1, M2, and M3) media on the growth of

oyster mushroom mycelium on observations 1 and 2 weeks after inoculation. While the observations on 3, 4, 5, 6, 7 and 8 weeks, has significantly different on the growth of oyster mushroom mycelium. The average growth of oyster mushroom mycelium is presented in (Table 1).

Table 1. Mean of Growth of Mycelium of White Oyster Mushroom (cm) from first week to eight week after inoculation.

Media	Growth of mycelium of White Oyster Mushroom (weeks)							
	1	2	3	4	5	6	7	8
M ₁	2,24	4,38	5,99 b	7,17 b	8,89 b	10,68 b	13,64 b	14,89 b
M ₂	2,28	3,39	3,92 a	4,37 a	5,56 a	6,52 a	7,51 a	8,72 a
M ₃	1,84	3,64	4,48 ab	4,82 ab	5,52 a	5,98 a	6,83 a	7,54 a
BJN 5 %	-	-	1,90	2,37	3,16	3,99	4,78	5,21

Explanation: ^a Abbreviation as in table 1 indicated value in the same column with different letter are statistically different ($p < 0.05$)

From the test results using HSD 5 % on 3 and 4 week observations showed that white oyster mushroom mycelium growth on sawdust media (M1) was not significantly different compare to the media of oil palm fruit fiber (M3) but significantly different from oil palm empty fruit bunches (M2). The average growth of oyster mushroom mycelium on sawdust media is the highest value 5.99 and 7:17 cm.

The result of observation of the growth of oyster mushroom mycelium on observations 5, 6, 7, and 8 week showed that the white oyster mushroom mycelium growing on sawdust media (M1) was significantly different from the media of oil palm empty fruit bunches (M2) and oil palm fruit fiber (M3). The average value of growth of oyster mushrooms mycelium on sawdust media showed the highest on 5, 6, 7, and 8 week with valued at 8.89, 10.69, 13.64, and 14.89 cm respectively. The comparison of the three oyster mushroom growing media is shown that the best medium for the growth of the oyster mushroom mycelium was sawdust media. This is due to the availability of nutrient content and decomposition of sawdust media which enable faster than the media of oil palm empty fruit bunches and oil palm fruit fibers. This is in accordance with the opinion of Djarijah and Djarijah (2001) that in the early development of the mycelium, the fungus break through the wood cell walls. In the process of penetration (drilling) of wood cell walls assisted by cellulose enzymes, hemicelluloses, and lignin, which is secreted by the fungus mycelium lateral. Enzymes digest compounds of wood and use it as a source of food of fungus.

B. Production of White Oyster Mushroom

From the observation of white oyster mushroom production showed that planting media affect the production of white oyster mushroom. Total production of white oyster mushrooms can be presented in Table 2.

Table 2 shows that in the first week of harvesting, M1 is able to grow 8 bag log of 9 replicates whereas the M2 and M3 can only grow 1 bag log of 9 replicates.

In the third week of harvesting, M1 media (7 baglog), M2 media (6 bag log) and M3 media (1 bag log). In the fifth week of harvesting, there were 8 bag logs (M1), 5 bag logs (M2) and 4 bag logs (M3). While in the seventh week of harvesting, M1 (7 bag logs), M2 (2 bag logs) and M3 (1 bag log) from 9 replications. Based on the total bag log, it can be seen that sawdust media (M1) is the highest production (30 bag log), followed by oil palm empty fruit bunches (M2) with 14 bag log and the last, oil palm fruit fiber media (M3) with 7 logs are produced.

Table 2. Production of White Oyster Mushroom (g)

Media	Number of bag log harvested (week)				Total
	1	3	5	7	
M ₁	8	7	8	7	30
M ₂	1	6	5	2	14
M ₃	1	1	4	1	7
Total	10	14	17	10	51
Media	Total production of white oyster mushroom (g)				Total
	1	3	5	7	
M ₁	678.5	475.35	418.66	256.36	1828.87
M ₂	17.22	360.41	113.92	63.95	555.50
M ₃	44.55	47.65	123.58	26.95	242.73
Total	740.27	883.41	656.16	347.26	2627.10

Based on the total production of white oyster mushroom of the three media (M1, M2, and M3) shows that the highest production achieved by M1 media (1828.87 g), followed by M2 (555.50 g) and the last M3 (242.73 g). The above results indicate that the production of sawdust media is the highest, so sawdust the best media in the production of white oyster mushroom. This is because wood is rich of cellulose and the substrate good for oyster mushroom cultivation. High content of cellulose will increase the cellulose enzyme, the production of this enzyme have a positive relationship with the formation of fungal bodies, as reported that cellulase activity on the substrate will create and enhance the production of high yields. While M3 (palm fruit fiber) with high lignin content affect cellulase activity, substrates containing lignin and phenol compounds in high amounts will lower cellulase activity. Lignin degradation by fungi are going to increase phenol and pholifenol oxidase compounds, phenol compounds are substances that are toxic to fungi (Sulistyarini, 2003).

C. Wet Weight of White Oyster Mushroom

Total number of wet weight of white oyster mushroom during study can be seen in table 3.

Table 3. Wet weight (g) of White Oyster Mushroom (1, 3 ,5, 7 weeks)

Media	Wet weight (g) (1, 3, 5, 7 weeks)				Total
	1	3	5	7	
M ₁	678.500	475.35	418.66	256.36	1828.870
M ₂	17.22	360.41	113.92	63.95	555.500
M ₃	44.55	47.65	123.58	26.95	242.730
Total	740.270	883.410	656.160	347.260	2627.100

According to Foth cited Irianto et al., (2004) the wet weight showing the water content in tissues or other organs except organic materials. Table 3 shows that of the three white oyster mushroom growing media, the media of sawdust gave the highest wet weight (1828,870 g), while the lowest wet weight of the oil palm fruit fiber media that is 242 730 g. According to Sumarsih 2009, oyster mushrooms are generally grown on sawdust media, because it is capable to decompose the lignin and cellulose, or are lignoselulolitik. Based on these properties, the fungus can be grown in other materials that contain lignin cellulose, such as straw, grass, bagasse (sugarcane bagasse), plant a variety of agricultural wastes, waste paper and so forth, but the production may differ.

D. Dry Weight of White Oyster Mushroom

From the observation of total dry weight of white oyster mushroom is presented in Table 4.

Table 4. Dry weight (g) of White Oyster Mushroom (harvested at 1,3,5 and 7 week).

Media	Dry weight (g) (week)				Total
	1	3	5	7	
M ₁	66.28	45.05	40.65	29.66	181.64
M ₂	3.30	39.01	17.87	8.96	69.14
M ₃	4.32	5.91	11.99	4.03	26.25
Total	73.90	89.97	70.51	42.65	277.03

Dry weight is the result of a process of growth after the moisture was removed to determine the actual weight. Based on the dry weight of white oyster mushroom, the highest production is in sawdust media with 181.64 g, while the lowest dry weight is in oil palm fruit media with 26.25 g. Dry weight is seen as the accumulation of organic compounds produced in the cell metabolism (Sitompul and Guritno cited Wiryanto, 2008).

E. Analysis of pH and Nutrient Content of Media

Result of pH analysis and nutrient content of N-total, P-total, K-total, Na-total, Ca-total, C, and Mg-total from sawdust media (M1), oil palm empty fruit bunches (M2) and

fibers oil palm fruits (M3) before and after harvest oyster mushrooms can be seen in the following graph.

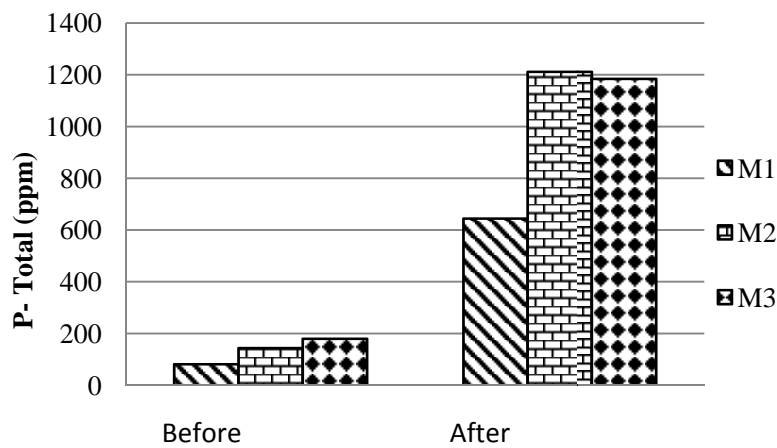
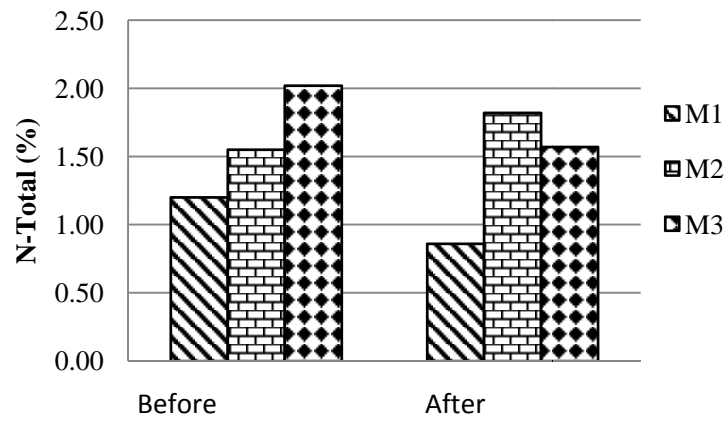
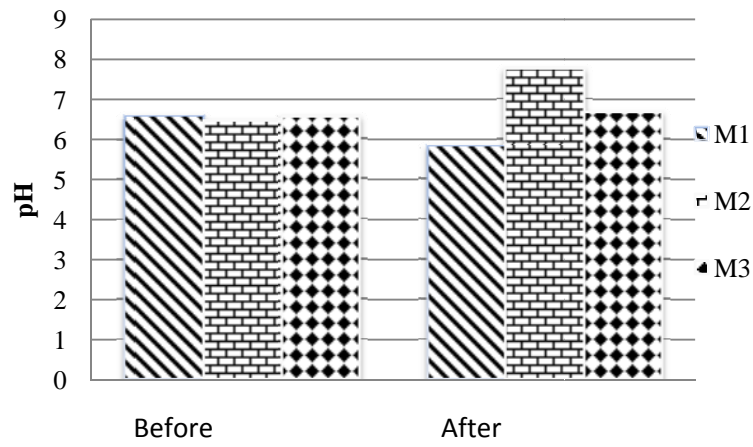

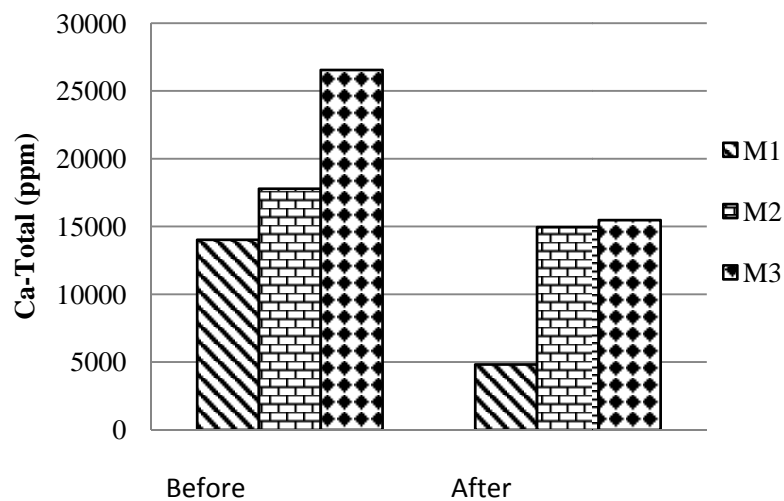
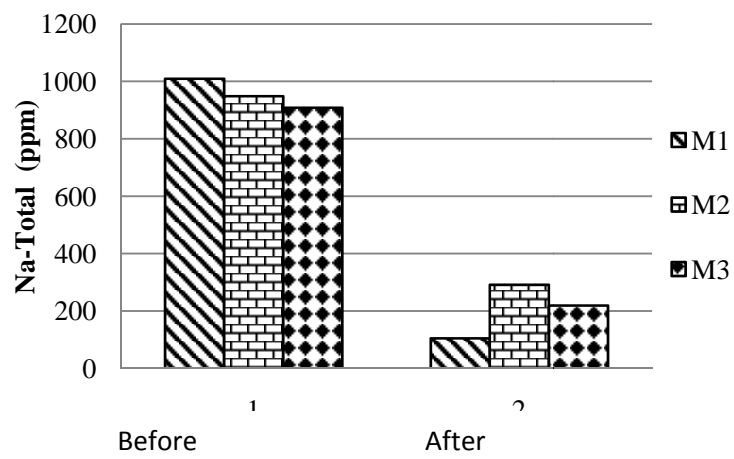
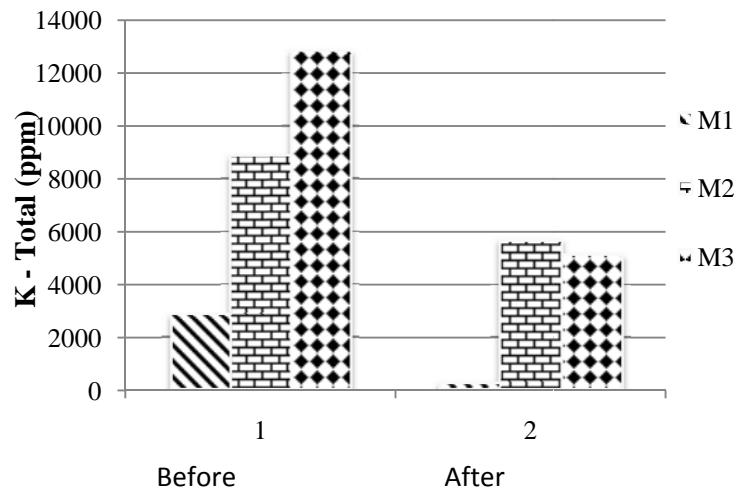

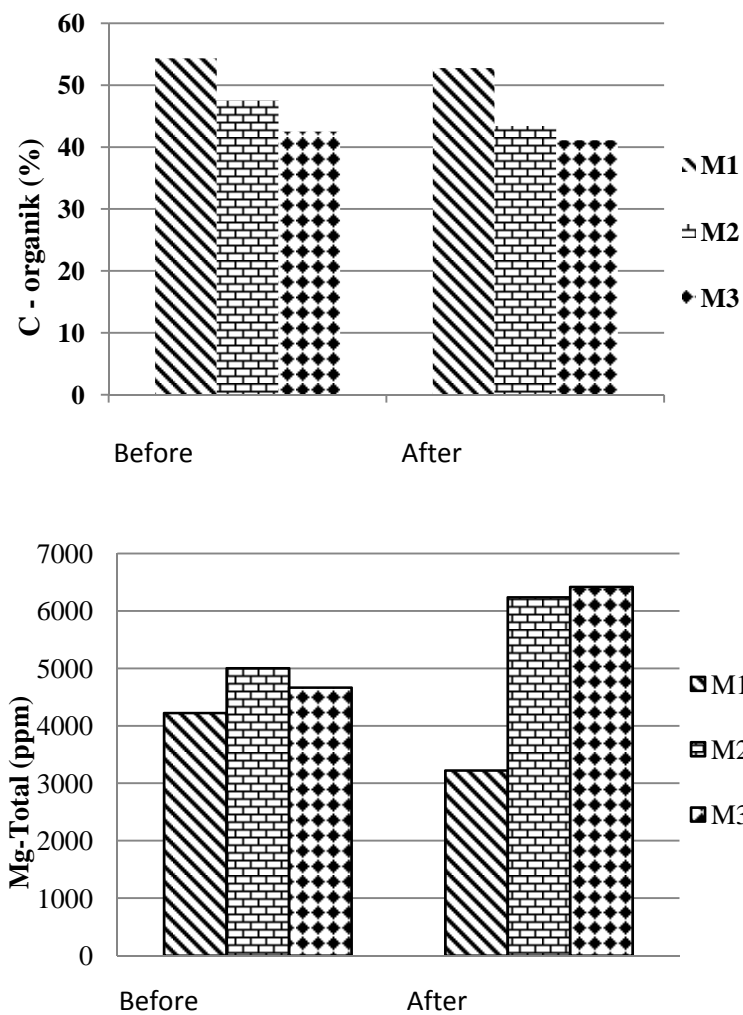

Result of nutrient analysis of the three media used in the study showed that there is change on nutrient content after oyster mushroom cultivation. For sawdust media (M1), nutrients decreased are N, K, Na, Ca, C, Mg while nutrient increase is P. The media of oil palm empty fruit bunches (M2) nutrient decrease are K, Na, Ca, C, while for the nutrients increase are N, P and Mg. The media of oil palm fibers (M3) nutrients decreased are N, K, Na, Ca, C, while nutrient increase P and Mg. This shows the existence of decomposition and absorption of nutrients occurs in the process of degradation.

The absorption process of nutrients in the white oyster mushroom growing media was done by white oyster mushroom mycelium. Absorbed nutrients are used as fungal metabolism for survival. Some elements are less than before due to the absorption of nutrients by the white oyster mushroom. Elements phosphorus (P) in all media has increased, this is due to at the beginning of preparation of bag log, TSP fertilizer granule added to all the media and seems P uptake by the fungus only a small amount. For Mg nutrient, there was an increase in media of oil palm empty fruit bunches (M2) and oil palm fibers (M3), while the sawdust media decreased. This happened because the preparation of bag log, dolomite added, resulting in the addition of Mg, but because of the growth and production of oyster mushrooms on sawdust media so well caused the Mg content of sawdust media is low. In contrast, the media of oil palm empty fruit

bunches (M2) and oil palm fibers (M3), fungal growth and production were so low, so the absorption of nutrients Mg was also limited.

Nutrient content of K, Na, C on the three mushroom growing media declined after fungal inoculation is understandable because of the above nutrients were absorbed by the oyster mushrooms and no additional nutrients at preparation of bag log, while Ca was also a decline although at preparation bag log was added through dolomite. This happens because the amount of Ca absorbed quite large by mushrooms.

Not all nutrients can be absorbed by fungus because the fungus only absorb nutrients used for growth. This is accordance with Rachmatullah (2009) the growth of oyster mushroom require nutrients for the body's metabolism, nutrients required, such as, carbon, source of carbon in the form of monosaccharides, polysaccharides, cellulose and lignin (wood), nitrogen is also useful to accelerate growth and the mineral calcium .

CONCLUSIONS

Nutrient analysis results on sawdust media, oil palm empty fruit bunches and palm fibers that had been planted with white oyster mushrooms showed a decline in most nutrients. Sawdust media is the best medium for mycelial growth and production of white oyster mushrooms followed by oil palm empty fruit bunches and the last is oil palm fibers.

Although the production of white oyster mushroom of the oil palm empty fruit bunches media is lower than sawdust media, but it should be given attention considering the abundance of oil palm empty fruit bunches media in Central Kalimantan, so it needs further research in order to obtain optimal results. For example, the need for further research on other types of wood fungus, so it can be utilized to the public in an oil palm plantation.

ACKNOWLEDGEMENT

The research was funded by DIPA BOPTN University of Palangka Raya 2012 number: 0720/023-04.2.01/17/2012.

REFERENCES

- Agus G.T.K., Agus, K.T dan Dianawati, A. 2001. Jamur Kayu. PT. Agromedia Pustaka. Jakarta.
- Andayani, R. 2010. Pembuatan Bioethanol dari Tandan Kosong Kelapa Sawit Melalui Proses Fungal Treatment oleh *Aspergillus niger* dan Fermentasi oleh *Zymomonas mobilis*. ITS. Surabaya. (diglib.its.ac.id/public/its-master-17188-2308201004.presentation.pdf).
- Arofathullah N.A, 2011. Pengomposan Tandan Kosong KelapaSawit. (http://bangunindonesia.com /index.php?option=com_content&view = article&id= 51: tkks&catid=34:penyuluhan).

- Asi Y., Wahyudiningsih, T.S.dan Sarinah, 2002. Prospek dan Potensi Limbah Tandan Kosong Sawit Untuk Media Budidaya Jamur Tiram (*Pleurotus ostreatus*). Jurnal Agripeat Vol.3 no. 2.
- Djarajah N. M., dan Djarajah, A. S. 2001. Budidaya Jamur Tiram. Kanisius. Yogyakarta.
- Rachmatullah, 2009. Kebutuhan Nutrisi Jamur Tiram dalam Media Tumbuh. (<http://bisnisjamur.wordpress.com/2009/2009/10/22/kebutuhan-nutrisi-jamur-tiram-dalam-media-tumbuh>).
- Sulistyarini, 2003. Produksi Jamur Tiram Putih Pada Media Campuran Serbuk Gergaji dan Sekam Padi. Thesis. UNDIP. Semarang. (<http://eprints.undip.ac.id/29642/>)
- Sumarsih, S. 2009. Pemanfaatan bagasse (ampas tebu), jerami dan sekam sebagai media tumbuh jamur Tiram Merah (*Pleurotus flabelatus*). Fakultas pertanian universitas pembangunan nasional “veteran” Yogyakarta. <http://ejournal.unesa.ac.id/index.php/lenterabio/article/view/414/330>.
- Irianto Y., Susilowati, A., Wiryanto, 2004. Pertumbuhan, Kandungan Protein, dan Sianida Jamur Kuping (*Auricularia polytricha*) pada Medium Tumbuh Serbuk Gergaji dan Ampas Tapioka dengan Penambahan Pupuk Urea. Universitas Sebelas Maret, Surakarta. <http://biosains.mipa.uns.ac.id/C/C0502/C050201.pdf>.
- Wiryanto, 2008. Kandungan Protein dan Sianida Jamur Kuping (*Auricularia polytricha*) pada Medium Tumbuh Serbuk Gergaji dan Ampas Tapioka dengan Penambahan Pupuk Urea. Jurusan Biologi, FMIPA UNS Surakarta. (<http://Biosains.mipa.uns.ac.id/C/C0502/C050201.pdf>).

GROWTH AND YIELD OF SWEET POTATO VARIETIES USING ORGANIC AND INORGANIC FERTILIZERS AND VERMITEA

Ana Maria F Maglalang¹, and Tessie E Navarro²

¹Tarlac College of Agriculture, Camiling, Tarlac, Philippines

²Tarlac College of Agriculture, Camiling, Tarlac, Philippines

Email: anamaria.maglalang@yahoo.com¹ and tessienavarro@yahoo.com²

ABSTRACT

The growing interest for sweetpotato as food and feed necessitates increasing its yield which could be attained through correct use of fertilizer. With the current trends and advocacy on mitigating climate change, producing sweetpotato organically is timely. This study evaluated the performance of two sweetpotato varieties using organic (vermicompost) and inorganic fertilizers (urea, 45-0-0, complete fertilizer 14-14-14) and frequency of vermitea application. An area of 1,164 sq m was laid out in Split Strip Design in a 2 x 4 x 4 factorial experiment. Based on the results, the biggest sweetpotato storage roots were obtained with the application of higher level of inorganic fertilizer at 75% inorganic fertilizer in combination with 25% organic fertilizer and vermitea spraying at three weeks interval. Super Taiwan UPLSp₆ gave higher marketable root yield compared to Super Bureau VSp₆. Marketable root yield significantly increased with weekly and at three week intervals of vermitea application. Weekly application of vermitea to sweetpotato registered the lowest incidence of the disease 21 days after planting (DAP) and application of higher level of inorganic fertilizer with 25% Organic + 75% RR IOF and 50% Organic + 50% RR IOF. UPLSp₆ applied with 25% organic fertilizer + 75% inorganic fertilizer and vermitea at three (3) weeks interval resulted to the highest percentage return on investment.

Keywords: *vermicompost, vermitea, Split Strip Design, mitigating climate change, RR IOF (recommended rate inorganic fertilizer).*

INTRODUCTION

Sweetpotato (*Ipomoea batatas* L.) locally known as “camote” is one of the most important crops grown by many farmers in Central Luzon for its storage roots which contain high levels of provitamins A and Vitamin C. It is rich in carbohydrates and its nutritional value has been recognized worldwide. It contains protein, dietary fiber, lipid and essential minerals and nutrients such as calcium, phosphorus, magnesium, sodium, potassium, sulfur, iron, copper, zinc, magnesium, aluminum and boron.

Fertilization is one of the factors to increase crop yield. The use of mineral fertilizers is necessary because it increases the yield in accordance with increasing requirements; it

replaces the large quantities of nutrients mostly lost through crop removal; it makes infertile soils more productive; and it corrects temporary nutrient deficiencies (Tisdale and Nelson, 1975).

There has been increasing interest on the use of organic fertilizer as main source of essential nutrients for plants as well as for the improvement of soil productivity. Organic materials like animal manures, crop residues, green manure as well as organic commercial fertilizers have relatively low nutrient contents but contain most, if not all the essential plant nutrients including heavy metals which could be harmful. The inorganic fertilizer on the other hand contains relatively higher concentrations but only a few of the essential nutrients.

The greatest benefits from organic materials in the soil is the overall improvement in soil condition, the development maintenance structure, the improvement of physical properties, the decrease susceptibility to erosion, the encouragement of microbial activity and the provision of potentially available nutrients (Buckman and Brady, 1994).

Soils widely vary in their level of fertility or the capacity of supplying the nutrient elements essential for plant growth. Most of our soils, however, are depleted because of leaching, crop removal, soil erosion, etc. Hence, the soil is exhausted and that insufficient level of nutrients is absorbed by the plants for their growth and development which will result to a very low yield.

For this reason, the addition of nutrients to soil which involves the use of organic and inorganic fertilizer application is necessary in order to produce maximum yield. The study, therefore aimed to evaluate the performance of two sweetpotato varieties using organic and inorganic fertilizer and frequency of vermitea application.

MATERIALS AND METHODS

A. Land Preparation and Field Lay-out

An area of 1,164 sq m was used in the study. This was conducted at Camiling, Tarlac, Philippines from January to April, 2012. The field was thoroughly prepared and was laid out in split-strip plot design with the following treatments: Main treatment – Variety (V), V₁ Super Bureau (VSP₆). The sub-treatment – Frequency of Vermitea application (TA) as T₁ – no vermitea (Control), T₂ – weekly application, T₃ – two weeks interval and T₄ – three weeks interval. For the sub- sub treatment – Fertilizer application (FA) as F₁ – Control (No fertilizer application), F₂ – 25% organic (Vermicompost) + 75% recommended rate of inorganic fertilizer (RRIOF), F₃ – 50% organic (Vermicompost) + 50% of RRIOF and F₄ – 75% organic + 25% RRIOF .

B. Preparation of Planting Materials

Stem cuttings Super Taiwan (UPLSp6) and Super Bureau (VSp6), 30 cm long with 6-8 nodes were obtained from clean planting materials. Cuttings were planted in the field with one stem per hill at a distance of 70 cm between rows and 30 cm between hills.

C. Fertilizer and Vermitea Preparation and Application

Sweetpotato plants were fertilized based on the recommendation of the Bureau of Soils (8 bags/ha of organic fertilizer, 4 bags/ha – urea, 4 bags /ha-14-14-14) following the different treatments. The organic fertilizer was basally applied at planting along the furrows. One half of the recommended rate of inorganic fertilizer was applied at planting and the other half was applied two weeks after planting. Also four liters of the concentrated compost tea were diluted with 12 liters of untreated water making a total volume of 16 liters. The frequency of application was based on the sub-treatments.

D. Cultivation and Weeding and Irrigation and Harvesting

Off-barring was done two weeks after planting while hilling up was undertaken one month after planting. Weeding and irrigation was done to maintain the growth of the plants. Harvesting was done 105 days after planting.

E. Data Analysis

All the data gathered were tabulated and were statistically analyzed using the Analysis of Variance for Strip Split Plot Design and treatment means were compared using the Duncan's Multiple Range Test (DMRT).

RESULTS AND DISCUSSION

A. Diameter of Storage Roots

Analysis of variance showed highly significant differences on the diameter of two sweet potato varieties. UPLSp₆ (Super Taiwan) obtained bigger diameter with a mean of 6.04 cm than VSp₆ (Super Bureau) with a mean of 5.57 cm. Results show that UPLSp₆ has genetically bigger storage root than VSp₆.

Likewise, the frequency of vermitea application significantly affected the diameter of the diameter sweet potato root. Vermitea application at three weeks interval significantly increased of sweetpotato roots with a mean of 6.77 cm compared to two weeks interval, weekly application and the control with means of 5.79, 5.50, and 5.17 cm, respectively. The differences on the diameter were attributed to the beneficial effect of vermitea to the plants. This was claimed to have been caused by plant growth regulators in vermitea as a result of microorganism interaction (Edwards, 2010) and the production of biggest roots at three weeks interval confirmed by Williams (2010) who stated that crude tea extract produces hormone, vitamins, nutrients, enzymes, amino acids and minerals needed by the plants.

Significant differences among the four treatment combinations using organic and inorganic fertilizer were noted. The biggest diameter of sweet potato root was obtained in F2 – 25% Organic + 75% IOF with 6.34 cm compared to the other treatments with the lowest value obtained from unfertilized plots of 5.34cm. However, F3- 50% Organic + 50% IOF and F4- 75% Organic + 25% IOF have similar effect on the diameter of sweetpotato root. These results conform with the findings of Guiam (2003) who observed that application of higher levels of inorganic fertilizers at 100%, 75% and 50% produced bigger storage roots than those applied with higher levels of organic fertilizer.

No significant interaction effects existed between varieties tested, the application of organic and inorganic fertilizer and the frequency of vermitea application.

B. Length (cm) of Sweetpotato Storage Root

No significant differences was observed on the two sweetpotato varieties applied with inorganic and inorganic fertilizer.

Results revealed highly significant differences on the length of sweetpotato roots as affected by vermitea application. The application of vermitea at three weeks interval significantly increased the length of sweetpotato roots at an average of 14.71 cm while the shortest roots were obtained in control plants with a mean of 12.23 cm. However, weekly and two weeks interval of application have comparable effects on the length of sweet potato roots. The increase in length of roots as a result of vermitea application can be attributed to its macro and micronutrients as stated by Williams (2010). Findings of Edwards *et al.*, (2005) on the effects of a range of concentrations of teas showed significant increase in growth and yield of plants even at as low as 5% compared to no tea application.

Plants applied with 25% Organic + 75 % RR IOF significantly produced the longest sweet potato roots with a mean of 14.96 cm followed by 50% organic + 50% RR IOF and 75% organic + 25% RR IOF and control with means of 13.50, 13.10 and 12.45 cm, respectively. However, F4 have similar effects with F3 and F1 on the length of sweet potato roots. This result shows that sweetpotato was more responsive to higher proportions of inorganic fertilizer treatments.

No significant interaction effect resulted between the use of organic and inorganic fertilizer and frequency of vermitea application.

C. Yield of Marketable Storage Root (kg/plot)

The yield of marketable storage roots produced by the two varieties varied significantly.

It can be noted that UPLSp₆ produced higher yield with a mean of 12.16 kg than VSp₆ with mean of 7.07 kg. The difference in the marketable yield of the two varieties can be attributed to the incidence of disease where VSp₆ showed higher incidence of the disease resulting in lower yield.

Significant effect of frequency of vermitea application. Plants applied weekly with vermitea registered the highest yield of sweetpotato which was comparable to plants applied with vermitea at 3 weeks interval with means of 10.79 kg and 9.70 kg, respectively. The result of the study can be attributed to the effect of vermitea that provided macronutrients and micronutrients that are required by plants for their growth and development.

Significant differences existed among fertilizer treatments in the marketable yield of sweet potato roots.

Among the different proportions of organic and inorganic fertilizer applied, highest yield of marketable root was obtained in 25% organic + 75 RR IOF (F2) with a mean of 11.81 kg followed by 50% organic + 50% RR IOF with a mean of 10.20 kg. Likewise, 75% organic + 25% RR IOF and control had similar effect on the yield of sweetpotato

roots with means of 8.56 kg and 7.87 kg, respectively. Results imply that higher levels of inorganic fertilizer compared to organic fertilizers are needed for the development of storage roots.

Significant interaction effects were noted between varieties and fertilizer application. VSp₆ applied with various combinations of inorganic and organic fertilizers has marketable root yield ranging from 7.84-6.67 kg which was found to be comparable with each other. The lower yield of VSp₆ compared to UPLSp₆ can be attributed to higher incidence of the disease “kamote kulot”. On the other hand, UPLSp₆ applied with 25% organic + 75% RR IOF gave the highest marketable root yield with a mean of 15.79 kg and the lowest was noted on unfertilized. The results imply that a higher level of inorganic fertilizer in combination with organic fertilizer is needed for the development of storage roots. As stated earlier, inorganic fertilizers readily provide the nutrients needed for the development of storage root. Organic fertilizer improved the physical condition of the soil which enhanced the absorption and utilization of readily available nutrients provided by inorganic fertilizer.

D. Incidence of Insect Pests

The insect pests observed were the following: insect pests as leaf feeders, tortoiseshell beetle (*Aspidomorpha milliaris*), cutworm (*Spodoptera litura*), slant-faced grasshopper (*Attractomorpha psitticina*), sweetpotato bug (*Physomerus grossipes*); insect pest that damaged the roots: sweetpotato weevil (*Cylas formicarius*); insect that transmit virus like white fly (*Bemisia tabaci*).

E. Percent Disease Incidence 15, 21, 30 DAP

No significant differences existed among the varieties, fertilizer treatments and frequency of vermitea application in percent disease incidence at 15 DAP.

However, the incidence of the disease of two sweetpotato varieties as affected by vermitea and fertilizer application at 21 and 30 DAP showed significant results respectively.

Significant result shows that higher incidence of disease was noted in VSp₆ compared to UPLSp₆ with means of 25.13%, 30.03% and 9.02% and 7.97% at 21 and 30 DAP, respectively. Results imply that VSp₆ is more susceptible to the attack of the disease “kamote kulot” compared to UPLSp₆.

Vermitea sprayed to plants at different frequencies of application significantly affected the incidence of the disease 21 DAP. Weekly application of vermitea registered the lowest percent disease incidence with a mean of 14.58% while the highest was observed from control with a mean of 19.79%. This can be attributed to the presence of beneficial microorganisms present in the tea. As cited by Scheurell and Manhaffe (2002), living microorganisms present in compost tea stimulate nutrient uptake and plant growth when applied to plants which increases disease resistance.

Plants sprayed with vermitea at 30 DAP showed also significant results. Plants not sprayed with vermitea exhibited the highest percent incidence of the disease among

treatments with a mean of 23.76% compared to other treatments sprayed with vermitea showing comparable effect with each other.

The result of the study can be attributed to the effect of vermitea showing that it can reduce or suppress the incidence of the disease. Eco-cycles-Microbe Brew (2004) cited that vermicompost tea is rich in nutrients and effective microorganisms making it a powerful plant tonic that encourages healthy growth and suppress pathogenic organisms in the soil.

Likewise, the application of organic and inorganic fertilizer in sweetpotato plants 21 and 30 DAP significantly affected the percent disease incidence. Plants not applied with fertilizer at 21 days after planting and 30 DAP gave the highest percent incidence of the disease with a mean of 22.39% and 26.21%, respectively compared to plants applied with different proportions of organic and inorganic fertilizer. The result suggest that varying proportions of organic and inorganic fertilizers showed proper balance fertilization as an effective means of controlling the disease by taking into account uptake of elements from the soil Making the plants resistant to the attack of pathogens causing diseases to plants.

Significant interaction effect was obtained between varieties of sweetpotato and frequency of vermitea application on the percent disease incidence at 21 DAP.

Variety VSp₆ with weekly application and two weeks interval of vermitea application obtained lower incidence of disease (19.41% and 23.41%, respectively) compared to plants applied with vermitea at three weeks interval and no application of vermitea . This result can be attributed to the source of planting materials, VSp₆ cuttings were taken from Mayantoc and UPLSp₆ were sourced out from Paniqui. According to the information gathered, sweetpotato plants in Mayantoc, Tarlac were infected with the disease “camote kulot” but supposed to be disease free as the mother plants were claimed to be sweetpotato clean planting materials (SPCPM).

Similarly, a significant interaction effect was noted on percent disease incidence of sweetpotato varieties applied with different proportions of organic and inorganic fertilizer at 21 DAP.

VSp₆ with no fertilizer application obtained the highest percent incidence of the disease with a mean of 34.02% compared to plants applied with different proportions of organic and inorganic fertilizers. Lowest incidence of the disease was noted when applied with 25% organic + 75% inorganic fertilizer with a mean of 21.52%.

Result of the study shows that organic fertilizer when added to the different proportions of the recommended rate of inorganic fertilizer tends to increase tolerance to the disease. As cited by Philam *et al.* (1995), one of the effective means of controlling disease is proper balanced fertilization by taking into account the elements from the soil.

On the other hand, UPLSp₆ applied with different proportions of organic and inorganic fertilizers showed comparable results on the percent incidence of disease with means ranging from 6.60% to 11.10%. This can be attributed to the genetic make-up of the planting materials in terms of resistance to disease infection.

Furthermore, significant interaction effect was obtained between fertilizer treatment combinations and frequency of vermitea application. Highest incidence of the disease was observed on plants without fertilizer and those that were not sprayed with vermitea

(35.41%). Plants sprayed with vermitea at two weeks interval, three weeks interval and weekly application decreased disease incidence. Lowest incidence of the disease was registered in plants not applied with fertilizer but sprayed with vermitea at two weeks interval (20.83%).

However, plants applied with 25% organic + 75 RR IOF applied with different frequencies of vermitea application showed comparable responses with each other on the percent disease incidence. Similar trend was observed on plants fertilized with 50% organic + 50 % RR IOF and 75% organic + 25% RR IOF sprayed with various frequencies of vermitea application which lowered the percent of disease incidence compared to untreated plants. This can be attributed to the addition of organic fertilizer which increases resistance to plant diseases. Chaw (2005) stated that soils with high organic matter exhibit good soil fertility and an active biological activity of microorganisms that provides food for beneficial microorganisms preventing plants from infection of the disease.

F. Number of Marketable Storage Root per Plot

Significant differences existed between the two varieties of sweetpotato tested on the number of marketable storage roots applied with varying proportions of organic and inorganic fertilizer and frequency of vermitea application.

Variety UPLSp₆ obtained the highest number of marketable storage root per plot while the lowest yield obtained from VSp₆. This is due to the effect of high disease incidence in VSp₆.

Vermitea sprayed at different frequencies of application significantly increased the number of marketable storage roots. Plants with weekly application registered the highest number of storage root produced with a mean of 84.18. The increase in yield as a result of vermitea spraying can be attributed to the hormones, vitamins, nutrients it contains (Williams, 2010) acting as fertilizer (Worm Farming, 2010).

The application of varying proportions of organic and inorganic fertilizers had significantly affected the production of marketable roots per plot. Plants applied with 25% organic + 75 % IOF and 50% organic fertilizer + 50% IOF produced more marketable storage roots with means of 92.26 and 79.80. Plants applied with 75% organic + 25% IOF, and the unfertilized plants produced lesser marketable roots with means of 68.54 and 62.98, respectively. Results of the study suggest that plants were more responsive to higher levels of inorganic fertilizer than those with higher levels of organic fertilizer which can be attributed to readily available nutrients from inorganic fertilizers which were used in the development of storage roots. Organic fertilizer, however, is known to improve the physical condition of the soil which enhances the nutrient uptake and efficient utilization of nutrients.

No significant interaction effects were noted between fertilizer application and the frequency of vermitea application.

Significant interaction effects existed between varieties and fertilizer application.

V1 applied with different proportions of organic and inorganic fertilizer were comparable in terms of number of marketable storage roots produced. This can be

attributed to the heavy virus infestation of VSp₆ plants which resulted to almost similar number of storage roots in all treatments.

Vermicompost may also have contributed to increase in the number of marketable roots developed. The effects of which are attributed to the quality of mineral nutrition and hormones it provides (Arancon *et al.*, 2005) resulting to higher yield in other crops like ginger (Guerrero, 2009).

G. Computed Yield of Marketable Storage Root (tons/ha)

UPLSp₆ obtained higher computed yield of marketable roots with a mean of 16.50 tons/ha compared to VSp₆ with a mean of 9.83 tons/ha. This is due to VSp₆ showed higher disease incidence.

The frequency of vermitea application showed significant effect on the computed yield per hectare of sweetpotato roots. Weekly application of vermitea resulted to higher yield of sweetpotato roots with a mean of 15.60 tons/ha, and this was comparable to spraying at two weeks interval (14.01 tons/ha). The lower yield was obtained from plants with three weeks interval spraying

Likewise, significant differences in computed root yield per hectare as affected by organic and inorganic fertilizers were noted. Plants applied with 25% organic + 75% RR IOF and 75% organic + 25% inorganic obtained higher computed root yield per hectare with means of 14.83 and 13.39 tons, respectively, than plants applied with 50% organic + 50% IOF and the control (12.60 t/ha and 11.85 t/ha). Inorganic fertilizers readily provided the nutrients needed for plant growth and root development. Organic fertilizer improved the physical condition of the soil which enhanced the absorption and utilization of nutrients.

Moreover, significant interaction effects existed between the two varieties tested applied with different fertilizer combinations. VSp₆ applied with different combinations of organic and inorganic fertilizer were comparable. Result can be attributed to the incidence of the disease where VSp₆ showed higher incidence of the disease resulting to similar response to fertilizer application combinations.

Furthermore, UPLSp₆ applied with 25% organic + 75% inorganic obtained the highest marketable root yield per hectare. Result showed that the plant is more responsive to higher proportions of inorganic and organic fertilizer treatment, followed by 50 - 50 combinations of organic and inorganic fertilizers. Inorganic fertilizers readily provided the needed elements needed for plant growth and root development.

H. Cost and Return Analysis

The summary on cost and return analysis of the different factors, varieties and treatment combinations shows that UPLSp₆ applied with 25% organic + 75% RR IOF with 3 weeks interval of vermitea application revealed the highest return on investment (ROI) of 283.77% while VSp₆ applied with 25% organic +75% RR IOF and no vermitea application obtained 55.37% ROI (Table 1).

Conclusively, the results imply that for VSp₆, it was economical and profitable if plants are applied with 25% organic + 75% RR IOF even without vermitea application.

Moreover, UPLSp₆ applied with 25% organic +75% RR IOF and spraying with vermitea at 3 weeks interval proved to be more economical and more profitable.

Table 1 . Summary table on cost and return analysis of one hectare production of VSp₆ and UPLSp₆ applied with vermitea and organic and inorganic fertilizer

ITEM	F1T1	F1T2	F1T3	F1T4	F2T1	F2T2	F2T3	F2T4
Gross Sales	4528000	5600000	5008000	41,36000	64,16000	6664000	5064000	6936000
Total Cost of Production	33,49400	4629400	3989400	3829400	41,29400	5529400	4889400	4729400
Net Income	11,78600	9,70600	10,18600	3,06600	22,86600	11,34600	1,74600	2206600
Return per peso Cost	1.35	1.21	1.26	1.08	1.55	1.21	1.04	1.47
ROI (%)	35.19	20.97	25.53	8.01	55.37	20.52	3.57	46.66

Table 1 . continuation

Table1 . Summary table on cost and return analysis of one hectare production of VSp₆ and UPLSp₆ applied with vermitea and organic and inorganic fertilizer

ITEM	F3T1	F3T2	F3T3	F3T4	F4T1	F4T2	F4T3	F4T4
I. Gross Income	54,64000	74,64000	52,00000	66,64000	50,00000	58,64000	54,64000	50,16000
Total Cost of Production	39,49400	53,49400	47,09400	45,49400	37,69400	51,69400	45,29400	43,69400
Net Income	15,14600	21,14600	4,90600	21,14600	12,30600	6,94600	9,34600	6,46600
Return per peso Cost	1.38	1.40	1.10	1.46	1.33	1.13	1.21	1.15
ROI (%)	38.35	39.53	10.42	46.48	32.65	13.44	20.63	14.80

Table 1. continuation

Table 1. Summary table on cost and return analysis of one hectare production of VSp₆ and UPLSp₆ applied with vermitea and organic and inorganic fertilizer

ITEM	F1T1	F1T2	F1T3	F1T4	F2T1	F2T2	F2T3	F2T4
Gross Income	10626000	10263000	10318000	11550000	15290000	19701000	16313000	18150000
Total Cost of Production	3349400	4629400	3989400	3829400	4129400	5529400	4889400	4729400
Net Income	72,76600	56,33600	63,28600	77,20600	111,60600	141,71600	114,23600	134,20600
Return per peso Cost	3.17	2.22	2.59	3.02	3.70	3.56	3.34	3.84
ROI (%)	217.25	121.69	158.64	201.61	270.27	256.30	233.64	283.77

Table 1. continuation

Table 1. Summary table on cost and return analysis of one hectare production of VSp6 and UPLSp6 applied with vermitea and organic and inorganic fertilizer

ITEM	F3T1	F3T2	F3T3	F3T4	F3T1	F4T2	F4T3	F4T4
Gross Income	117370.00	165660.00	147400.00 0	134530.00	99000.00	131780.00	120120.00	109120.00
Total Cost of Production	39494.00	53494.00	47094.00 100306.00	45494.00	37694.00	51694.00	45294.00	43694.00
Net Income	77876.00	112166.00	0	89036.00	61306.00	80086.00	74826.00	65426.00
Return per peso Cost	2.97	3.10	3.13	2.96	2.63	2.55	2.65	2.50
ROI (%)	197.18	209.68	212.99	195.71	162.64	154.92	165.20	149.74

CONCLUSIONS

This study was conducted to determine the performance of two sweetpotato varieties using organic and inorganic fertilizer and frequency of vermitea application.

Based on the results of the study, the following conclusions are drawn:

1. UPLSp₆ gave bigger diameter of storage roots, compared with Super Bureau as affected by fertilizer treatment and frequency of vermitea application. Also it has more marketable root yield when applied with higher combination level of inorganic and organic fertilizer. The application of vermitea at weekly and at three weeks interval results to higher yield of marketable root yield.
2. Higher level of inorganic fertilizer decreases the percent incidence of “camote kulot”.
3. Weekly application of vermitea results to lower incidence of “camote kulot”. Lowest incidence of “camote kulot” can be noted in plants not applied with fertilizer but sprayed with vermitea at two weeks interval. The application of organic and inorganic fertilizer and spraying of vermi tea did not affect the incidence of insect pest as exemplified by the negligible observed insect pest population.
4. VSP6-Super Bureau applied with different proportions of organic and inorganic fertilizers were comparable in terms of marketable root yield, number of marketable roots and computed yield. However, UPLsp₆-Super Taiwan applied with 25% organic + 75% inorganic fertilizer produced the highest marketable root yield, number of marketable roots and computed yield per hectare.
5. UPLSp₆ applied with 25% Organic + 75% RR IOF and sprayed with vermitea at three weeks interval has higher return of investment (ROI) of 283.77%.
6. The available Phosphorus (ppm) and exchangeable K (me/100g soil) decreases after planting.

RECOMMENDATIONS

Based on the results of the study, the researcher recommends the following:

1. The application of vermitea at three weeks interval and the application of 25 % Organic + 75 % RR IOF are recommended to increase the production of marketable root yield of sweetpotato.

2. To reduce the incidence of “camote kulot”, sweetpotato should be sprayed with vermitea at two weeks interval and applied with 25% organic + 75% RR IOF.
3. UPLSp₆ applied with 25% Organic + 75% RR IOF and sprayed at three weeks interval with vermitea is recommended since it obtained the highest return on investment.
4. Further studies need to be undertaken for further evaluation of the results.

LITERATURE CITED

- Arancon, N.Q., C.A. Edwards, and S. Lee. 2002. Management of plant parasitic nematode populations: Vermicomposts Proceedings Brighton Crop Protection Conference-Pests and Diseases. 8E716.
- Arancon, N.Q., C.A. Edwards, P. Bierman, C. Welch, and J.D. Metzger. 2003. The influence of vermicompost applications to strawberries: Part I. Effects on Growth and Yield. *Biores Technol*, in press.
- Arancon, N.Q., C.A. Edwards, R.M. Atiyeh, and J.D. Metzger. 2003. Effects of vermicomposts produced from organic waste on greenhouse peppers. *Biores Technol*. 93: 139-144.
- Atiyeh, R.M, S. Subler, C.A. Edwards, G. Bachman, J. D. Metzger and W. Shuster. 2000. Effects of vermicopost and compost on plant growth in horticultural container media and soil. *Pedobiologia* 44: 579-5
- Atiyeh, R.M, N.Q., Arancon, C.A. Edwards and J. D. Metzger. 2000. Influence of earthworm- processed pig manure on the growth and yield of greenhouse tomatoes. *Biores Technol* 75: 175-180.
- Chaoui, H, C.A. Edwards, A. Brickner, S. Lee and Nq. Arancon, 2002. Suppression of the plant parasitic diseases *Pythium* (damping off), *Rhizoctonia* (root rot) and *Verticillium* (wilt) by Vermicompost Brighton Crop Protection Conference-Pests and Diseases 8B-3: 711-716
- Chaw, L.M. and K. L. Heong. 2005. Effects of Organic Fertilizers on Insect Pests and Diseases of Rice. *Omonrice* 13:26-33.
- Jones, J. 1995. Using cultural Practices in Rice to Reduce Pests problems in crops. <http://agric.gov.ab.ca/pest/60510300.html>.
- Lalitha, R., K, Fathima and S.A. Ismail 2000. The Impact of Biopesticide and Microbial Fertilizers on Productivity and Growth of *Abelmoschus esculentus*. *Vasundara the Earth*. (1-2):4-9.
- Matthew. Worm Castings, The Best Way to Make a Brown Thumb Green. [http://ejst.teiath.gr/issue_2009/Rakshit_12.pdf](http://www.wormsect.com/worms-etc-blog/2010/04/wormcastings/>.2010.</p><p>Rakshit, A. 2009. Performance of <i>Abelmoschus esculentus</i> L. cv <i>Arka Anamika</i> (IIHR Sel 10) Grown in New Alluvial Region of West Bengal, India With Different Locally Available Organic Manures. <a href=).
- Rao, K.R. 2002. Induced host plant resistance in the management of sucking insect pests of ground nut. *Ann Plant Prot Sci* 10: 45-50.

- Szczech, M, B. Kowalska and U. Smolinska. 2002. Induction of systemic resistance in radish by pseudomonads. Developing in vermicomposts-amended substrate. *Phytopathology Polonica* 24: 57-66.
- Trankner,A. 1992. Use of Agricultural and Municipal Organic Wastes to Develop Suppressiveness to Plant Pathogens. *Biological Control of Plant Diseases*. Plenum Press, New York.
- Wormfarmingrevealed.com. All About Worm Tea. <http://www.wormfarmingrevealed.com/wormtea.html>. 2010.
- Zaller, J.G. 2006. Foliar Spraying of Vermicompost Extract: Effects on Fruit Quality and Indications of Late-Blight Suppression on Field Grown Tomatoes. *Biological Agriculture & Horticulture*.24, 165-180.

USE OF POULTRY MANURE AS CARRIER FOR BIOFERTILIZERS: EFFECTS ON MAIZE (*Zea mays*) GROWTH

Lawal Tunde Ezekiel And Babalola Olubukola Oluranti

Department of Biological Sciences, Faculty of Agriculture, Science and Technology,
North-West University, Mafikeng Campus, Private Bag X2046, Mmabatho 2735, South
Africa.

Email: zeklawal@yahoo.com

ABSTRACT

Maize (*Zea mays*) is a very important grain crop in sub Saharan African countries. Its production depends on correct application of production inputs that will sustain environment and profitable yield. Impact of biofertilizer application on growth and yield of maize was studied using poultry manure as the carrier of biofertilizer. Biofertilizer used was *Azospirillum* strain. Two station experiments were carried out on agronomic field in North-West University, Mafikeng Campus to determine growth and response of maize to biofertilization. Experimental design adopted was Completely Randomized Design in arrangement consisting of five manure treatments (T1, T2, T3, T4 and T5). The treatments contained 0, 5, 10, 15 and 20% levels of manure respectively. T6 was the control treatment which had no biofertilizer and poultry manure. Soil was mixed in 0, 5, 10, 15 and 20% (V: V) *Azospirillum* inoculated animal manure. Parameters measured were: plant height at maturity (cm), ear length (cm), number of grains per ear, biological yield (tha^{-1}), harvest index (%), 500 grain weight (g) and grain yield (tha^{-1}). Crops responded positively to the inoculation and growth was limited in the absence of manure and inoculant. Significant ($P < 0.05$) differences were observed among the treatments with biofertilizer and treatments with biofertilizer and T6. Treatment with 15% *Azospirillum* inoculated poultry manure and T6 had 210 and 180cm heights at maturity respectively while harvest index were 35.2 and 29.4% respectively. Maize plants with inoculants had a higher tendency for biomass than the uninoculated ones and supports development of organic and sustainable agriculture.

Keywords: Poultry manure, biofertilizers, *Azospirillum* strains, maize

INTRODUCTION

Due to improvements in poultry farming, there is upward increase in the production of poultry manure and hence high tendency of its accumulation in our vicinity. Moreover, due to the onward increase in the cost of chemical fertilizers, it is therefore necessary for farmers to begin to consider the possibility of working on animal manure and use it as a replacement for chemical fertilizers for plant better performance. Poultry manure is

the organic waste resources from poultry farm animals consisting of droppings from poultry. However, it may be a mixture with some of the bedding materials, for example, wood shavings and feathers. Poultry manure can be broken down easily and because of its rapidity in mineralizing the soil under conducive temperature and moisture, its use is embraced (Morin *et al* 2011 and Nadrowski *et al* 2010). Manure, being organic in nature, may be added as organic materials into the soil. It improves fertility of soil by enhancing organic matter and nutritional materials which ensures the addition of nutrients such as nitrogen, phosphorus and potassium. Apart from supplying nutrients to crops, animal manure acts as soil amendment agent and thereby enhancing the soil organic matter bioavailability. Moreover, animal manure enhances the water holding capacity of the soil, lowers soil bulk density, and improves overall soil structure; thereby increasing crop production and food availability (Yoldas *et al* 2008 and Zaki *et al* 2009).

In the last century, farmers were happy about the discovery and the use of chemical fertilizers due to improvement in crop yield and subsequent financial gains that accrued to them. However, demerits in the use of chemical fertilizers emerged and some of them include: leaching and pollution of water basins, destroying micro-organisms and friendly insects, making crops more susceptible to attack from diseases, reducing the soil fertility and hence, farmers were being discouraged to use them (Babalola 2010; Natarajan *et al* 2012 and Prasanna *et al* 2012). In addition, overtime, it has been realized that the alternative to chemical fertilizers may actually be biofertilizers using animal manure as carrier.

Biofertilizers are live formulates which contain living microorganisms which, when applied to seed, plant surfaces, root or soil, inhabit the rhizosphere and enhance the bioavailability of nutrients and increasing the microflora through their biological activities and thereby enhancing plant's growth; they are preparations that readily improve the fertility of land using biological agents. Biofertilizers are from biological wastes and they are not hazardous to soil (Babalola 2010; Babalola and Glick 2012; Chen *et al* 2011; Prasanna *et al* 2012 and Prasanna 2013). They are very useful in that they help in enriching the soil with the microorganisms and these microorganisms produce organic nutrients for soil and help in fighting pathogens. Besides accessing nutrients, for current intake as well as residual, different biofertilizers also provide growth-promoting factors to plants and some have been successfully facilitating composting and effective recycling of solid wastes.

Biofertilizers, depending on available or present microorganisms have come up as a replacement for chemical fertilizers to enhance soil fertility and crop yield in sustainable agriculture (Niederholtmeyer *et al* 2010). Symbiotic, free-living soil bacteria are named as plant growth-promoting rhizobacteria (PGPR). They are involved in important ecosystem developments, and their activities include biological control of plant pathogens, N fixation, mineralization of nutrients and phytohormones production (Babalola and Glick 2012, Mihali *et al* 2008 and Vessey 2003) because of these qualities, they occupy a unique place in the sustainability of agroecosystems. The main sources of biofertilizers are bacteria, fungi, and cyanobacteria (blue-green algae). The relationship that these organisms have with plants is referred to as symbiosis. In this case, both partners derive benefits from each other. Maize (*Zea mays* L.) is one of the highly valued grain crops in South Africa and is prominent in all parts of the country under different environments.

Successful maize production relies on good usage of production inputs that will enhance the environment as well as its production. These inputs include: cultivation of good cultivars, soil tillage, fertilization, weed, insect and disease control, harvesting, marketing and financial resources. In developing countries like South Africa, maize is produced and consumed directly and serves as staple food for some 200 million people. Majority of the people see maize as a breakfast cereal. Notably, after due production process, it is also used for the production of fuel (ethanol) and starch. Afterwards, starch in turn involves enzymatic conversion into products such as sorbitol, dextrine, sorbic and lactic acid, and appears in household items such as beer, ice cream, syrup, shoe polish, glue, fireworks, ink, batteries, mustard, cosmetics, aspirin and paint. Approximately 8.0 million tons of maize grains are produced in South Africa annually on approximately 3.1 million ha of land and half of the production consists of white maize, for human food consumption. Proper utilization or management of animal manure can prevent environmental pollution, improvement in the maize performance and guarantees the change of manure from waste to wealth.

MATERIALS AND METHODS

The experiment was conducted at the North-West University (Mafikeng Campus) Teaching and Research Farm, North-West Province, South Africa. Impact of biofertilizer application on growth and yield of maize was studied using poultry manure as the carrier of biofertilizer. Biofertilizer used was *Azospirillum* strain. Two station experiments were carried out on agronomic field in North-West University, Mafikeng Campus to determine growth and response of maize to biofertilization. The initial soil sample was taken to determine fertility level of soil before sowing the grains. Experimental design adopted was Completely Randomized Design (CRD) in arrangement consisting of five manure treatments (T1, T2, T3, T4 and T5). The treatments contained 0, 5, 10, 15 and 20% levels of manure respectively. T6 was the control treatment which had no biofertilizer and poultry manure. Soil was mixed in 0, 5, 10, 15 and 20% (V: V) *Azospirillum* inoculated animal manure. All other agronomic practices were kept normal and uniform for all the treatments. Data of various yield parameters such as plant height at maturity (cm), ear length (cm), number of grains per ear, biological yield (tha^{-1}), harvest index (%), 500 grain weight (g) and grain yield (tha^{-1}) were recorded. The obtained data were subjected to analysis of variance (ANOVA) according to the procedure of Steel and Torrie (1980) and means were separated by Duncan's multiple range test where there were significant differences using Statistical Analysis System (SAS) 1999 package.

RESULTS AND DISCUSSION

Table 1 shows that plant height was significantly ($P < 0.05$) affected by the application of *Azospirillum* strain using the poultry manure as the carrier. The maximum plant height of 210.00cm was obtained in treatment with 15% manurial treatment (T4). The lowest plant height was observed in treatment with 0% biofertilizer and 0% poultry manure. Plant height is one of the important parameters to measure the effect of the biofertilizer. As the height of the plant increases and the leaf area increases, it gives the plant the privilege of having more areas for photosynthesis. Biofertilizer treatments increased the heights of the plants. This may be due to the fact that the biofertilizer has the potential

of building and maintaining soil fertility (Onasanya et al. 2009; Kong et al. 2008 and Farhad et al. 2009). It can also improve soil tilts, increase water-holding capacity, lessen wind and water erosion and improve aeration, but at the 20% inclusion level the growth began to nosedive (200.20 cm). This may suggest excessive application of manure. Manure should not be applied in quantities that exceed the amount needed for adequate plant nutrition. This is important because excess application may induce nutrient deficiencies in the soil and increase the potential for excess nutrients to enter waterways (Hedge and Sudhaka Babau 2001; Kolawole and Samson, 2009).

Table 1: Effect of poultry manure as carrier for biofertilizers (*Azospirillum* strain) on growth and yield of maize (*zea mays*)

Treatments	Plant height at maturity (cm)	Ear length (cm)	Number of grains per ear	Biological yield (tha^{-1})	Harvest index (%)	500 grains weight (g)	Grain yield (tha^{-1})
(T1) 0% manure but with biofertilizer	184.21 ^c	16.47 ^c	596.31 ^c	15.61 ^c	31.0 ^c	131.28 ^c	4.28 ^c
(T2) 5% manure	192.34 ^b	16.88 ^c	600.01 ^c	16.22 ^b	33.21 ^b	143.34 ^b	5.79 ^c
(T3) 10% manure	198.10 ^b	17.92 ^{ab}	621.28 ^b	16.98 ^b	33.79 ^b	148.51 ^a	6.01 ^b
(T4) 15% manure	210.00 ^a	18.90 ^a	712.14 ^a	19.85 ^a	35.20 ^a	150.14 ^a	7.11 ^a
(T5) 20% manure	200.20 ^{ab}	17.27 ^{ab}	641.00 ^b	18.79 ^a	35.11 ^a	149.11 ^a	6.00 ^b
(T6) 0% biofertilizers, 0% manure	180.00 ^d	15.24 ^c	504.13 ^d	15.11 ^c	29.40 ^c	120.31 ^d	5.12 ^c
SEM	1.45	0.21	1.51	0.31	0.40	1.52	0.41

a, b, c, means on the same column with different superscripts are significantly different ($P < 0.05$)

The maximum ear length was recorded in treatment with 15% manurial application level (18.90 cm) while the minimum was observed in T6 (15.24 cm) and this was followed by treatment with 10% application level. The ear length was affected significantly ($P < 0.05$) by different levels of manure and biofertilizers application. All the treatments led to more ear length when compared to the two controls. The increase in ear length could be due to application of biofertilizers (in this case, *Azospirillum* strains) otherwise referred to as a plant growth promoting rhizobacteria (PGPR). PGPR has been reported to have the ability to stimulate phytohormones, mobilize phosphate, enhances siderophores production, antibiotic production, inhibit plant ethylene synthesis and induce plant systemic resistance to pathogens (Leli et al, 2009; Bashan and de-Bashan 2010 and Mahmood et al. 2001).

In addition, significant ($P < 0.05$) differences were observed in number of grains per ear and number of grains per ear have direct influence on grain yield of maize per unit area. As seen in Table 1, all the treatments were affected significantly. The maximum number of grains (712.14) per ear were counted in maize in T4 and this was followed by T5 (17.27). In T6, the minimum number of grains (504.13) was observed. Biological yield is shows total dry matter production of crop during its life span. From the obtained results, the biological yield of maize was significantly ($P < 0.05$) affected by the biofertilizer. This increase could possibly be due to sufficiency of Nitrogen (Rudesh et al. 2005; Six et al. 2006; Stephens & Rask 2000 and Wu et al. 2005). Application of manurial treatment at 15% showed the highest biological yield (19.85tha^{-1}) and the least result was shown at treatment without manure and *Azospirillum* strains (T6).

Harvest index is the ratio of grain weight to total plant weight. It shows the division of photosynthates between the grains and the vegetative plant and improvements in the harvest index reveals the importance of carbon allocation in grain production. From this study, it was observed that T4 and T5 were significantly ($P < 0.05$) different from T2 and T3. Besides, it was also significantly ($P < 0.05$) different from T1 and T6. Increased harvest index could be associated mainly to a greater increase in grain yield numerical components (i.e. kernel number and/or kernel weight) than in shoot biomass. The 500 grains weight is an important parameter in yield determination. It shows the extent or degree of seed development and determination of grain quality and yield per hectare. The obtained data for the 500 grains weight shows that all the treatments increased 500 grain weight above the control. Grain yield can be expressed as the product between shoot biomass and harvest index. It is the ultimate goal of all the grain crops. This important parameter is associated with many factors such as plant density and nutrient availability. Notably, reduction or enhancement of any of the factors may affect the crop yield. In this work, the maximum grain yield (7.11tha^{-1}) was observed in T4. This was followed by T5 and T3 which were 6.00 and 6.01tha^{-1} respectively. The least grain yield was noted in T1 (4.28tha^{-1}). The increase in grain yield was possibly due to wider range of nutrients, particularly micronutrients made available by the biofertilizers *Azospirillum* strains and its carrier (poultry manure) which would have helped in increasing soil organic matter content of the soil and consequently the grain yield.

CONCLUSION

The work has shed more light on the possibility of enhancing maize growth via the application of *Azospirillum* strains as biofertilizer poultry manure as the carrier as there was tremendous improvement in the plant height at maturity, ear length, number of grains per ear, biological yield, harvest index and grain yield.

REFERENCES

- Babalola O.O (2010). Beneficial Bacteria of Agricultural Importance. *Biotechnol. Lett.* 32:1559-1570.
- Babalola O.O, Glick B.R (2012). The use of microbial inoculants in African agriculture: Current practice and future prospects. *J. Food Agric. Environ.* 10 (3&4): 540-549.
- Farhad, W., M. F. Saleem, M. A. Cheema and M. H. Hammad (2009) Effect of poultry manure levels on the productivity of spring maize. *J. Anim. Plant Sci.* 19 (3): 122-125.
- Kolawole, E. and U. Samson (2009) Growth and Yield of Maize as Influenced by Sowing Date and Poultry Manure Application. *Not. Bot. Hort. Agrobot. Cluj*, 37 (1): 199-203.
- Kong, W. D., Y. G. Zhu, B. J. Fu, X. Z. Han, L. Zhang and J.Z He (2008) Effect of long-term application of chemical fertilizers on microbial biomass and functional diversity of a black soil. *Pedosphere.* 18(6): 801-808.

- Lelei, J. J., R. N. Onwonga, and B. Freyer (2009) Organic based nutrient management strategies: Effect on soil nutrient availability and maize (*Zea mays*L.) performance in Njoro, Kenya. *African J. Agr.* 4 (2): 092-099.
- Mahmood, M. T., M. Maqsood, T. H. Awan, and S. Rashid (2001) Effect of different levels of Nitrogen and intra-row plant spacing on yield and yield components of maize. *Pakistan J. Agri. Sci.* 38 (1-2): 48-49.
- Mihali T.K, Kellmann R, Muenchhoff J, Barrow K.D and B.A Neilan (2008). Characterization of the gene cluster responsible for cylindrospermopsin biosynthesis. *J. Appl. Environ. Microbiol.* 74: 716-722.
- Morin, X., L. Fahse, M. Scherer-Lorenzen and H. Bugmann (2011). Tree species richness promotes productivity in temperate forests through strong complementarity between species. *Ecol. Lett.* 14: 1211-1219.
- Nadrowski, K., C. Wirth and M. Scherer-Lorenzen (2010). Is forest diversity driving ecosystem function and service? *Curr. Opin. Environ. Sust.* 2: 75-79.
- Natarajan C, Prasanna R, Gupta V, Dureja P and L. Nain (2012). Dissecting the fungicidal activity of *Calothrixelenkinii* using chemical analyses and microscopy. *J. Appl. Biochem. Microbiol.* 48:53-57.
- Niederholtmeyer H, Wolfstadter B.T, Savage D.F, Silver P.A and J.C Way (2010). Engineering cyanobacteria to synthesize and export hydrophilic products. *J. Appl. Environ. Microbiol.* 76: 3462-3466.
- Onasanya, R. O., O. P. Aiyelari, A. Onasanya, S. Oikeh, F. E. Nwilene, and O. O. Oyelakin (2009). Growth and yield response of maize (*Zea mays* L.) to different rates of nitrogen and phosphorus fertilizers in southern Nigeria. *World J. of Agr. Sci.* 5 (4): 400-407.
- Prasanna R, P. Jaiswal, J. Shrikrishna, M. Joshi, L. Nain, A. Rana and Y.S Shivay (2012). Evaluating the potential of rhizo-cyanobacteria as inoculants for rice and wheat. *J. Agric. Technol.* 8: 157-171.
- Prasanna R, E.Sharma, P. Sharma, A. Kumar, R. Kumar, V. Gupta, R.S Pal, Y.S Shivay and L. Nain (2013). Soil fertility and establishment potential of inoculated cyanobacteria in rice crop grown under non-flooded conditions-Paddy. *J. Water Environ.* 11:175-183.
- Ranganayaki, N., Tilak, K.V.B.R., Manoharachary, Ch, Mukerji, K.G (2006). Methods and techniques for isolation, enumeration and characterization of rhizosphere microorganisms. In:
- Mukerji, K.G., Manoharachary, C., Singh, J. (Eds.), *Microbial Activity in the Rhizosphere*. Springer Verlag, Berlin, Heidelberg, Germany, pp. 17-38.
- Roldán, A., Salinas-García, J.R., Alguacil, M.M., Díaz, E., Caravaca, F (2005). Soil enzyme activities suggest advantages of conservation tillage practices in sorghum cultivation under subtropical conditions. *Geoderma* 129, 178-185.

- Rudresh, D.L., Shivaprakash, M.K., Prasad, R.D (2005). Effect of combined application of *Rhizobium*, phosphate solubilizing bacterium and *Trichoderma* spp. On growth, nutrient uptake and yield of chickpea (*Cicer aritenium* L.). *Appl. Soil Ecol.* 28, 139-146.
- Six, J., Frey, S.D., Thiet, R.K., Batten, K.M (2006). Bacterial and fungal contributions to C-sequestration in agroecosystems. *Soil Science Society of America Journal* 70, 555-569.
- Statistical Analysis System Institute Inc., (1999). SAS/STAT Programme, Carry, NC: SAS Institute Inc.
- Steel, R.G and Torrie, J.H (1980). *Principles and Procedures of Statistics*. McGraw-Hill, New York, NY.
- Stephens, J.H.G., Rask, H.M., (2000). Inoculant production and formulation. *Field Crops Research* 65, 249-258.
- Vessey J.K (2003). Plant growth promoting rhizobacteria as biofertilizers. *J. Plant and Soil.* 255:571-586.
- Wu, S.C., Cao, Z.H., Li, Z.G., Cheung, K.C., Wong, M.H (2005). Effects of biofertilizers containing N-fixer, P and K solubilizers and AM fungi on maize growth: a greenhouse trial. *Geoderma* 125:155-166.
- Yoldas, F., S. Ceylan, B. Yagmur & N. Mordogan (2008). Effect of nitrogen fertilizer on yield quality and nutrient content in broccoli. *J. Plant Nutr.* 31:1333-1343.
- Zaki, M.F., A.A.M. Abdelhafez, Y. El-dewiny & T.R. Camilia (2009). Influence of biofertilization and nitrogen sources on growth, yield and quality of broccoli (*Brassica oleracea* Var. *Italica*). *Egypt. J. Appl. Sci.* 24: 86-111.

THE EFFECT OF VARIOUS FERTILIZERS ON THE GROWTH OF OIL PALM SEEDLINGS IN THE MAIN NURSERY

Pauliz Budi Hastuti¹, Ni Made Titiaryanti² *

¹ Faculty of Agriculture Institut Pertanian Stiper, Yogyakarta, Indonesia

² Faculty of Agriculture Institut Pertanian Stiper, Yogyakarta, Indonesia

* email: pauliz@instiperjogja.ac.id

ABSTRACT

Nutrients in the form of fertilizer is needed to support the growth of oil palm seedlings in the main nursery. This experiment was carried out to determine the effect of various fertilizers on the growth of oil palm seedlings in the main nursery. The factorial experiment was arranged in a completely randomized design. The first factor was the fertilizer type which consists of four levels, namely formula fertilizer, NPKMg fertilizer, the compost tea of oil palm empty fruit bunches + formula fertilizer, and the compost tea of oil palm empty fruit bunches. The second factor was the varieties of oil palm which consist of three levels, namely DXP Yangambi, DXP Langkat and DXP Simalungun. The results showed that the fertilizer of the compost tea of oil palm empty fruit bunches + formula fertilizer produced the best growth of oil palm seedlings in the main nursery. The DXP Yangambi variety produced better seedling growth than the other varieties.

Keywords: *Oil palm seedlings, main nursey, empty fruit bunches, compost tea, formula fertilizer*

INTRODUCTION

Oil palm is one of the most important estate crops in Indonesia. In the last two decades, the total area of oil palm in Indonesia has increased sharply from less than 1 million hectares in 1989 to more than 8.9 million hectares in 2011 with a production of 23,096,541 tons of CPO (Directorate General of Estate Crops, 2012). The development of oil palm plantation areas requires rapid provision of seedlings.

The nursery system mostly applied in oil palm plantations is single-stage nursery in which sprouts are directly planted in large polybags, and double-stage nursery in which sprouts are grown and nurtured first in small polybags for three months, which is also called pre nursery. Furthermore, seedlings are transferred to large polybags and nurtured there for nine months, and the final stage is referred to as main nursery.

The selection of the formulation and dosage of fertilizer on the pre nursery is different from the main nursery. Indonesia Oil Palm Research Institute recommended that the fertilization on pre nursery be done by sprinkling or spraying on the leaves (foliar application) of the urea solution with a concentration of 0.1 to 0.2% (1-2 g liter⁻¹ of water to 100 seeds) or with a (15-15-6-4) fertilizer solution with a concentration of 0.15

to 0.3% (from 1.5 to 3 g liter⁻¹ of water for 100 seeds). The standard fertilization of oil palm seedlings in the main nursery at the age of 14-15 weeks is done by using NPKMg fertilizer (15:15:6:4) of 2.5 g, 5.0 g of aged 16-17 weeks, 7,5 g of 18-20 weeks and 10.0 g of 20-24 weeks. The fertilization of palm seedlings in the main nursery is carried out in the plantation using NPK, whose dosage is adjusted to the age of the plant (Akiyat, *et al.*, 2005).

Nowadays the dependence of the use of inorganic fertilizers for oil palm seedling fertilization is still high. This is because the effect of inorganic fertilizers is seen immediately and its application can be done more easily. However, if the land is fertilized with inorganic fertilizers continuously, there will be a decline in the efficiency of the fertilization.

Palm oil mill produces wastes which include palm empty fruit bunches (EFB) which are very abundant. Oil palm empty fruit bunches contain 42.8% C, 2.90% K₂O, 0.80% N, 0.22% P₂O₅, 0.30% MgO and micro elements such as 10 ppm B, 23 ppm Cu, and 51 ppm Zn (Buana *et al.*, 2003). These organic materials are not only useful as a supplier of nutrients that plants need but also able to increase soil fertility in the long term through improved physical and biological properties of soil (Stevenson, 1982).

The application of organic fertilizer in the form of empty fruit bunches of oil palm as mulch in oil palm plantations in general can increase the levels of N, P, K, Ca, Mg, C-organic, and soil cation exchange capacity. The increase of soil nutrient is followed by the increase of the production of fresh fruit bunches. Several researchers have shown that the increase of the production of fresh fruit bunches caused by the application of palm empty fruit bunches as mulch on some soil types ranges from 10% to 34%. The development of compost from empty fruit bunches of oil palm waste is not only useful for oil palm plantations, but also for improving soil fertility and productivity of crops (Darnoko and Sembiring, 2005).

In their utilization for crops, organic fertilizers in the form of compost can be extracted or be made in to compost tea (Alter & Michell, 1992; Augustien, 2007). Compost tea can also be used to control pathogens in plants (Brinton *et al.*, 1996 ; Scheuerell, 2003).

Compost tea of oil palm empty fruit bunches is made from composted oil palm empty fruit bunches which are put in a cloth bag and soaked in water for 14 days. Through the soaking of the compost, compost tea resulted. In this way, the nutrient content of compost tea of oil palm empty fruit bunches is more available for soil and plants. The research done by Rohmiyati *et al.*, (2006) showed that the application of organic manures (cow dung compost, chicken and straw) dissolved in the water could increase mustard yield. Compost dissolved with the ratio of 1: 3 shows the highest results of the mustard yield. The organic liquid fertilizer or compost tea made from the waste compost found in cities contained hormones auxin and was able to increase the production of red chili crop. The increase in the number of flowers, and fruits per plant and in the fruit weight per plant are respectively 14.59%, 20.63% and 35.45% when compared to control (using inorganic fertilizers) (Augustien, 2007).

The research done by Prabudi *et al.*, (2010) showed that the use of compost tea of oil palm empty fruit bunches at a dosage of 125 ml per plant produced the best root and plant dry weight of the mustard plant. This is significantly different if inorganic fertilizers is used. The research done by Khaswarina (2001) showed that the combination of Organic Soil Treatment plus N, P, K, and Mg (¼ the recommended

dosage) on the main nurseries of oil palm tends to give better results than all combinations of fertilizers used in the study .

This experiment was carried out to determine the effect of formula fertilizer, NPKMg fertilizer, the compost tea of oil palm empty fruit bunches +formula fertilizer, and the compost tea of oil palm empty fruit bunches on the growth of oil palm seedlings in the main nursery.

MATERIALS AND METHODS

The experiment was conducted at the Education and Research Field of Institut Pertanian Stiper, Maguwoharjo, Sleman, Yogyakarta, Indonesia.

The research material consisted of oil palm seedlings in the nursery around the age of 6 months, oil palm empty fruit bunches obtained from the Education and Research Field of Institut Pertanian Stiper in Ungaran, sugarcane / molasses, NPKMg (15:15:6:4) and formula fertilizer. Formula fertilizer used consisted of a stock solution A (1000 g $\text{Ca}(\text{NO}_3)_2$ and 40 g micro fertilizer completely dissolved in 5 liters of water) and stock solution B (500 g KNO_3 , 500 g KH_2PO_4 , 600 g of $(\text{NH}_4)_3\text{PO}_4$ and 800 g MgSO_4 dissolved in 5 liters of water) (Ginting, 2008). Each of the stock solution (A and B) whose dosage was 10 ml in 1 liter of water was used for oil palm seedling. The formula fertilizer given to the seedlings every morning was 2 liter per day. Once in every two weeks, 20 grams of NPKMg fertilizer was put around the seedlings and covered with soil.

The compost tea of oil palm empty fruit bunches was made from (75%) palm empty fruit bunches + (10%) cow manure + (5%) rice bran + (10%) gliriside leaves which were well-mixed. Then this mixture was given decomposers and also some water to 60% humidity and was turned upside down repeatedly every day. The finished compost (1kg) was put in a cloth bag and given 4 liters of water + 100 ml of molasses. Afterward it was incubated for 14 days. Every day this compost was put into and out of some water repeatedly. The compost tea of oil palm empty fruit bunches given to the oil palm seedlings every week was 200 ml plant⁻¹.

The factorial experiment was arranged in a completely randomized design. The first factor was the fertilizer type consists of four levels, namely formula fertilizer, NPKMg fertilizer, the compost tea of oil palm empty fruit bunches + formula fertilizer, and the compost tea of oil palm empty fruit bunches. The second factor was the variety type of oil palm which consists of three levels, namely (DxP) Yangambi, (DXP) Langkat and (DXP) Simalungun.

Observations were conducted on plant height at 6 months, plant height at 9 months, the increase in plant height, stem diameter at 6 months, stem diameter at 9 months, The increase in of stem diameter, midrib number at 6 months, midrib number at 9 months, the increase in the number of midrib and chlorophyll content. The analysis of compost tea of oil palm empty fruit bunches included N (Semi-micro Kjeldahl method), P (Bray I method), and K (ammonium acetate extraction using 1 N Flamefotometer).

Data were subjected to analysis of variance (F test) using SPSS program. The differences among treatment means were determined by Duncan's Multiple Range Test (DMRT) at $P < 0.05$.

RESULTS AND DISCUSSION

The analysis shows that there is no interaction between the kind of fertilizer and the kind of varieties of oil palm seedlings used for the growth of oil palm seedlings in main nursery. The results of the analysis are presented in Tables 1 and 2.

Table 1. The effect of the kind of fertilizer on the growth of oil palm seedlings in the main nursery

Parameter	Type of fertilizers			
	Formula	NPKMg	Compost tea of EFB + Formula	Compost tea of EFB
Plant height at 6 months (cm)	46,35 a	45,65 a	45,43 a	47,55 a
Plant height at 9 months (cm)	110,13 bc	116,60 a	114,00 ab	107,53 c
The increase of plant height (cm)	63,78 bc	70,95 a	68,57 ab	59,99 c
Stem diameter at 6 months (cm)	2,33 a	2,35 a	2,38 a	2,32 a
Stem diameter at 9 months (cm)	6,88 b	6,74 b	7,22 a	6,33 c
The increase of stem diameter (cm)	4,54 ab	4,39 bc	4,84 a	4,01 c
Midrib number at 6 months	10,87 a	10,20 b	10,13 b	10,13 b
Midrib number at 9 months	16,53 a	15,53 b	16,80 a	15,27 b
The increase of midrib number	5,67 b	5,33 b	6,67 a	5,13 b
The content of chlorophyll (Spad)	62,26 a	61,91 a	59,71 a	48,08 b

Note: The figures followed by the same letter on the line indicate no significant differences based on DMRT test at $P < 0,05$.

Producing good palm seedlings requires media which contain nutrients. But the nutrients which the media have are not sufficient for the growth of seedlings in the nursery, so fertilization is needed. The effect of the fertilizer can be seen in Table 1.

When formula fertilizer, NPKMg, compost tea of EFB + formula fertilizer and compost tea of EFB are given to oil palm seedlings in the main nursery diverse responses in their growth resulted. At the early stage of the experiment (at 6 months) the height and the stem diameter of the plants did not show significant differences. After being treated with various fertilizers, it was found out that the oil palm seedlings which were given NPKMg fertilizer had the greatest increase in height and the oil palm seedlings which were given compost tea of EFB + formula fertilizer had the same growth in height. NPKMg fertilizer and formula fertilizer are chemical fertilizers which are already available to plants.

Giving compost tea of EFB fertilizer + formula fertilizer to the oil palm seedling resulted in a better increase in the stem diameter and in the number of midribs when compared with the giving of the other fertilizers to the oil palm seedling. This is due to the fact that formula fertilizer contained both macro and micro nutrients which are badly

needed by the plants. Formula fertilizer was made from $\text{Ca}(\text{NO}_3)_2$, micro fertilizer complete, KNO_3 , KH_2PO_4 , $(\text{NH}_4)_3\text{PO}_4$ and MgSO_4 . When the formula fertilizer is used along with the compost tea of EFB, the plant growth is boosted. Although the macro nutrient content in formula fertilizer is low, but when it is repeatedly applied to the oil palm seedlings, it meets the need of the plant. Compost tea made from oil palm empty fruit bunches, despite its low element content (0.008% N, 687.5 ppm P, and 617.385 ppm K), contribute to the chemical, physical and biological improvement of soil properties. The use of compost tea combined with formula fertilizer for the oil palm seedlings has an advantage, because soil rich in organic matter is able to bind and store nutrients for plants that are positively charged metal elements, such as Ca, Mg, and K. If CEC soil increases, the soil will hold and release more nutrients for plant growth (Griffin, T. 2004).

According to Munawar (2011: 167), soil organic matter which accumulates in the soil serves as the storage and supplier of essential plant nutrient, because most of the soil organic matter derives from the remains of plants that contain all the nutrients needed by plants. Soil organic matter can improve soil properties which can maintain the availability of nutrients in the soil and can make the soil suitable for plant growth. However, the provision of compost tea of EFB did not show the proper growth of oil palm seedlings. This can be seen in treatment using the compost tea of EFB in which the increase in plant height, stem diameter and chlorophyll content is the lowest when compared with other treatments. This is because the nutrient content is low and its availability is slow.

In the treatment using compost tea of EFB, the chlorophyll content is lower than that of the other fertilizers because based on the analytical results it was found that N content is low. Formula fertilizer, NPKMg fertilizer and compost tea of EFB + formula fertilizer contained a lot of N and Mg, so the chlorophyll content was significantly higher. Besides being needed for the formation of protein, N is also an integral part of chlorophyll which is able to convert light into chemical energy needed for photosynthesis. Sufficient supply of N to plants is indicated by a high photosynthetic activity, good vegetative growth and dark green color of plants (Havlin *et al.*, 2005). Mg in plants is a component of the chlorophyll molecules in all green plants, and plays an important role in almost all plant metabolism and protein synthesis. Mg also functions as a co-factor of the whole enzyme that activates the process of phosphorylation (ATP) (Jones, 1998). The high content of chlorophyll will boost the process which will lead to an increase in the photosynthesis product. This can be seen from the fact that the treatment using formula fertilizer and compost tea of EFB + formula fertilizer resulted in the higher increase in stem diameter if compared with the other treatments.

Table 2 shows that at the early stage of the experiment (at 6 months), (DXP) Yangambi variety has plant height, stem diameter, and number of midrib which are better than the other varieties in the main nursery. Similarly, at the final stage of the experiment (at 9 months) (DXP) Yangambi variety has the best plant height and stem diameter. The increase in plant height, number of midrib and chlorophyll content of the three varieties is similar. This indicates that at 9 months (DXP) Yangambi variety has better growth if compared with (DXP) Langkat and (DXP) Simalungun. If the initial growth is better, the subsequent growth will be better too. This proves that the variety of (DXP) Yangambi from the early to the final stage in the main nursery shows better growth than the other varieties.

Table 2. The effect of the kind of varieties of oil palm on the growth of oil palm seedlings in the main nursery

Parameter	Kind of varieties		
	(DXP) Yangambi	(DXP) Langkat	(DXP) Simalungun
Plant height at 6 months (cm)	51,01 a	45,82 b	41,91 c
Plant height at 9 months (cm)	118,50 a	109,90 b	107,80 b
The increase of plant height (cm)	67,50 a	64,08 a	65,89 a
Stem diameter at 6 months (cm)	2,66 a	2,18 b	2, 20 b
Stem diameter at 9 months (cm)	7,32 a	6,66 b	6,40 b
The increase of stem diameter (cm)	4,66 a	4,48 ab	4,20 b
Midrib number at 6 months	11,10 a	10,30 b	9,60 c
Midrib number at 9 months	16,30 a	15,95 a	15,85 a
The increase of midrib number	5,20 b	5,65 ab	6,25 a
The content of chlorophyll (Spad)	56,68 a	60,13 a	57,16 a

Note: Note: The figures followed by the same letter on the line indicate no significant differences based on DMRT test at $P < 0,05$.

At the early stage of the experiment, the number of midribs of (DXP) Yangambi variety is greater than that of the other varieties. But the number of the midribs of (DXP) Simalungun variety is smaller. At the final stage of the experiment, the number of midribs is similar among all of the varieties. This is because the increase in the number of midribs of (DXP) Simalungun variety is higher than other varieties.

CONCLUSION

The results showed that the fertilizer of the compost tea of oil palm empty fruit bunches + formula fertilizer produced the best growth of oil palm seedlings in the main nursery. The (DXP) Yangambi variety produced better seedling growth than the other varieties.

REFERENCES

- Akiyat, W.Darmosarkoro & Sugiyono. 2005. Pembibitan Kelapa Sawit. Pusat penelitian Kelapa Sawit, Medan 25 p.
- Alter,D.and Michell.1992. Use of Vermicompost extract as an aluminium inhibitor in aqueous solution. *Soil Sci. Plant Anal.*23: 231-240.
- Augustien, N. 2007. Peranan Teh Kompos Terhadap Pertumbuhan dan Produksi Tanaman Cabe Merah Besar (*Capsicum annum*, L.) : Kajian Respon Tanaman Cabe Merah Besar Terhadap Perlakuan Jenis, Cara Pemberian dan Konsentrasi Teh Kompos. <http://adln.lib.unair.ac.id/>
- Brinton, W.F., T.Andreas & D. Mary. 1996. Investigations in to Liquid Compost Extracts. *Biocycle*. Emmaus. Vol. 37, Edisi 11.

- Buana,L., D.Siahaan dan S. Adiputra. 2003. Teknologi Pengolahan Kelapa Sawit. Pusat Penelitian Kelapa Sawit, Medan 128 p.
- Darnoko dan T.Sembiring. 2005. Sinergi antara perkebunan kelapa sawit dan Pertanian Tanaman Pangan Melalui Aplikasi Kompos Tandan Kosong Kelapa Sawit untuk Tanaman Padi. Pertemuan Kelapa Sawit 2005; Peningkatan Produktivitas Tanaman Kelapa Sawit Melalui Pemupukan dan Pemanfaatan Limbah Kelapa Sawit. Medan, 19-20 April 2005 : 138-151.
- Directorate General of Estate Crops. 2012. Plantation Area and Production throughout Indonesia by concession [http:// ditjenbun.deptan.go.id](http://ditjenbun.deptan.go.id) Accessed 5 March 2013.
- Ginting, C. 2008. Pengaruh Suhu Zona Perakaran terhadap Pertumbuhan dan Kadar Klorofil Tanaman Selada Sistem Hidroponik. *Agriplus* Vol.18 (03): 169-178.
- Griffin, T. 2004. Soil Organic Matter. <http://umaine.edu/publications/2288e/>, accessed 29 May 2013.
- Havlin,J.L.,Beaton,J.D.,Nelson,S.L.,and Nelson W.L.2005. Soil Fertility and Fertilizer. An Introduction to Nutrient Management, New Jersey: Pearson Prentice Hall.
- Jones J. Benton Jr. 1998. Plant Nutrition. Manual. CRC Press. Boca Raton, Boston, London, New York, Washington. 149 hlm.
- Khaswarina S, 2001. Keragaan Bibit Kelapa Sawit terhadap Pemberian Berbagai Kombinasi Pupuk di Pembibitan Utama. *Jurnal Natur Indonesia* III (2): 138 – 150.
- Munawar, A. 2011. Kesuburan Tanah dan Nutrisi Tanaman. IPB Press, 240 p.
- Prabudi,I.S.,R.Rebrianto, dan Sugiarto. 2010. Pemanfaatan Limbah Tandan Kosong Kelapa Sawit Sebagai The Kompos Pada Tanaman Hortikultura. Laporan PKM-P 2010. Instiper Yogyakarta.12 p.
- Rohmiyati,S.M., M. Surya dan P.B. Hastuti. 2006. Pengaruh Pelarutan dan Lama Inkubasi (dengan Aerasi) Bahan Organik Terhadap Hasil Sawi (*Brassica juncea*). *Buletin Ilmiah Instiper* 13 (1) : 1-11.
- Scheuerell, S. 2003. Understanding How Compost Tea Can Control Disease. *BioCycle*.Vol.44,Edisi 2.
- Stevenson,F.J. 1982. Humus Chemistry Genesis, Composition, Reactions. A Wiley-Interscience Publ. John Wiley & Sons. New York

GIBBERELIC ACID SYNTHESIS IN THE DEVELOPING SEEDS OF COCOA

Yohana Theresia Maria Astuti^{1*}, Kumala Dewi², Santosa², A. Adi Prawoto³

¹ Faculty of Agriculture, Institut Pertanian Stiper, Yogyakarta, Indonesia.

² Faculty of Biology, Universitas Gadjah Mada, Yogyakarta, Indonesia.

³ Pusat Penelitian Kopi dan Kakao Indonesia / ICCRI, Jember, East Java, Indonesia.

* Corresponding author: astuti_maria2000@yahoo.com

ABSTRACT

An experiment was carried out to determine gibberellic acid synthesis in the developing cacao seeds. Two cacao clones namely KW163 and KW165 were used. Several plants for each clone were selected and hand pollination was conducted before anthesis. Samples of healthy seeds were taken at 1, 2, 3, 4, 5, 6, 7, 8, 9, 10 weeks following hand pollination. Gibberellic acid content was determined by HPLC (High Performance Liquid Chromatography). Molecular study was carried out to know expression of *TcGA20ox* like gene on seeds aged seven weeks. The results showed that, in seeds aged 1-10 weeks, the gibberellic acid content in developing seeds of clone KW163 fluctuated from about 1068.10 ng.g⁻¹ fw at week 1 to 181.92 ng.g⁻¹ fw at week 10 and the gibberellin content in developing seeds of clone KW165 fluctuated from about 1762.49 ng.g⁻¹ fw at week 1 to 714.54 ng.g⁻¹ fw at week 10. *TcGA20ox* like gene that could be found in seeds indicated that there was gibberellic acid synthesis in the developing seeds.

Keywords: *Cocoa seed, synthesis, gibberellic acid, TcGA20ox like gene.*

INTRODUCTION

Cocoa flowers are formed on the trunk and branches, called cauliflorous (Cuatrecasas, 1964; Wood & Lass, 1984). Cocoa plants produce a lot of flowers. In general, only 1-5% of all flowers that had been pollinated could fruiting (Hasenstein & Zavada, 2001; Almeida & Valle, 2007). The hormones in the seeds affect seed sink strength for photosynthate (Nichols, 1960; Prawoto, 2000). Photosynthate allocation takes place from the leaves as a source to the food reserve storage organs and growing organs as sink (Ramsperger-Gleixner *et al.*, 2004; Turgeon, 2006). Photosynthate distribution in plant is affected by sink condition (Buckhout & Tubbe, 1996; Thorpe & Minchin, 1996). Gibberellic acid play a role in increasing the sink strength of tomato fruits that is important in their development (Ho, 1996). Competition among fruits, young fruits and young shoots of cocoa is possibly controlled by hormones internally (Nichols, 1960). In the fruit, there are a variety of hormones that interact in determining the formation and development of the fruit, such as auxin, cytokinin, gibberellic acid and abscisic acid (Baydar & Harmankaya, 2004; Grierson, 1995).

Gibberellic acid (GA) is a diterpenoid compound that regulate a variety of developmental processes such as seed germination, cell elongation, leaf growth and flower and fruit development (Olszewski *et al.*, 2002; Hu *et al.*, 2008). Gibberellic acid can be found in some parts of the plant, such as the internodus, petiolus, the young leaves, apical stems, the developing fruits and seeds and seed germination (Sponsel, 1995). In apple, the fruit development is stimulated by gibberellic acid (Richards *et al.*, 2001). Gibberellic acid is also found at an early stage of embryonic development in *Phaseolus vulgaris* seed. It shows that gibberellic acid is essential in embryonic development (Rock & Quatrano, 1995). The content of gibberellic acid in the seed determines the process of embryogenesis (Weiss and Ori, 2007). Some seeds synthesized gibberellic acid, such as the seeds of *Pisum sativum* L. (Ozga *et al.*, 2009), *Phaseolus vulgaris* L. (Rock & Quatrano, 1995), and *Arabidopsis thaliana* (Olszewski *et al.*, 2002). Gibberellic acid is found in the seed of avocado (*Persea americana* Mill.) (Blumenfeld & Gazit *cit.* Bower & Cutting, 1988). On avocado, auxin, gibberellic acid and cytokinin play a role in the process of fruit development (Blumenfeld, 1970). Auxin, gibberellic acid, cytokinin and abscisic acid are also detected in *Rosa roxburghii* fruit (Wei-guo *et al.*, 2004). The grape ripening is regulated by hormones. There is high gibberellic acid content in the early formation of the grape. The gibberellic acid content decreases on subsequent fruit development. In fruit of grapes of Perlette cultivar aged 20 –78 days, the content of gibberellic acid was about 300 ng.g⁻¹ fresh weight at 20 days, then decreased to about 50 ng.g⁻¹ fresh weight at 78 days (Baydar & Harmankaya, 2004). There is a change in the content of auxin, gibberellic acid and cytokinin in the growth and development of tomato fruit . The content of gibberellic acid in tomato fruit fluctuated during fruit development; it is varies approximately 600 - 830 ng.g⁻¹ fresh weight of tomato fruit (Kojima, 2005; Gillaspay *et al.*, 1993). There is a range of gibberellic acid content in the fruit development of pear (*Pyrus sp.*) of about 20-50 ng.g⁻¹ fresh weight in the early to middle stages of fruit development (0-50 days after pollination). In the mid to late stages of fruit development (80-130 days after pollination), the concentration of gibberellic acid decreased. It showed that gibberellic acid important in fruit development (Liu *et al.*, 2004).

Gibberellic acid biosynthesis can be divided into three stages, each with multiple steps. The first stage is the formation of ent-kaurene, the second stage is the oxidation of ent-kaurene to GA₁₂ and the third stage is the step from GA₁₂ to active gibberellic acids. There are several enzymes involved in the biosynthesis (Rademacher, 2000; Olszewski, 2002; Hu *et al.*, 2008). In the third stage, GA₁₂ and GA₅₃ are converted into GA₉ and GA₂₀ with the help of enzymes GA₂₀oxidase. GA₉ and GA₂₀ are converted to GA₄ and GA₁ with the help of enzymes GA₃oxidase. GA₄ and GA₁ are converted to GA₃₄ and GA₈ with the help of enzymes GA₂oxidase (Olszewski *et al.*, 2002; Hu *et al.*, 2008; Huizen *et al.*, 1997; Ait-Ali *et al.*, 1999; Kusaba *et al.*, 2001). Several genes involved in the biosynthesis of gibberellic acid in *Arabidopsis*, among others GA₂₀oxidase (Phillips *et al.*, 1995). There is *AtGA20oxidase* expression in *Arabidopsis* seed germination (Frigerio *et al.*, 2006) and *SbGA20oxidase* expression in embryos of sorghum (Flores *et al.*, 2003). In research on the biosynthesis of gibberellic acid in early fruit formation showed an increase in the transcription of genes which are encoding *PsGA20oxidase* in pear (Ozga *et al.*, 2009), an isolation of GA₂₀ox gene expression from pea seed (Huizen *et al.*, 1997) and the gene expression of GA₂₀ox on apple leaves, young stem and seed (Kusaba *et al.*, 2001).

This research aims to know the content of gibberellic acid and the *TcGA20ox* like gene expression in the young seeds of cacao.

MATERIALS AND METHODS

KW163 and KW165 clones of cacao which were planted at Indonesia Coffee and Cocoa Research Institute (ICCRI), Jember, East Java, were used in this study. Samples of fruit were the result of hand pollination without given treatment. Gibberellic acid content analysis was conducted on seeds from fruits aged 1 to 10 weeks with 3 replications. Analysis procedure of gibberellic acid content on cocoa seeds followed the procedure of Kelen *et al.* (2004). Gibberellic acid content was determined by HPLC (High Performance Liquid Chromatography).

RNA extraction was executed with Qiagen RNeasy Plant Mini Kit (20) reagen. Step work was done following the procedure in the reagent instruction. Concentration and purity of RNA was measured by spectrophotometer absorbance at 260 and 280 nm as follows: RNA concentration = $A_{260} \times 40 \times 50 \text{ mg.ml}^{-1}$; RNA purity = A_{260}/A_{280} .

Reverse Transcriptase - Polymerase Chain Reaction (RT - PCR) was executed with Qiagen longrange 2Step RT-PCR reagen. Step 1 is the synthesis of cDNA, while the second step is PCR cDNA. Step works were done following the procedures in the reagen instruction.

Primer of *TcGA20ox* like gene was obtained from the DDBJ DATA CUSTALW DNA sequences of *Cucurbita maxima* (AJ 308 480), *Populus trichocarpa* x *Populus deltoidea* (EF 148 790) and *Poncius trifoliata* x *Citrus sinensis* (AJ 250 187) as follows:

TcGA20ox-F: 5'-CTAYCCDCCRTGCCAAAARCC-3'

TcGA20ox-R: 5'-GCTRTTCACNACCGCYCDRTG-3'

Product size = 235 bp.

PCR program consisted of initial activation at a temperature of 93°C for 3 minutes, followed by 35 cycles consisting of denaturation at a temperature of 93°C for 15 seconds, annealing at a temperature of 50°C for 30 seconds and extension 68°C for 1 minute. In the final stage of the final extension, PCR was performed at a temperature of 68°C for 8 minutes. PCR results were stored at a temperature of -20°C. A total of 5 ml of PCR products were analyzed by electrophoresis on 1.2% agarose gel with a 100bp DNA ladder marker (Vivantis) 10 ml.

Table 2 shows that there is a RNA of *TcGA20ox* like gene in cocoa seeds of KW163 and KW165 clones. This suggests that there is a transcriptional activity of *TcGA20ox* like gene in cocoa seeds. Fig. 1 shows the expression of *TcGA20ox* like gene of cocoa seeds clone KW163 and KW165. GA20ox is one of the enzymes involved in the synthesis of gibberellic acid (Flores, *et al.*, 2003; Hu, *et al.*, 2008; Ozga *et al.*, 2009). This indicates that gibberellic acid is synthesized in the cocoa seeds.

RESULT AND DISCUSSION

Table 1. The content of gibberellic acid in cocoa seeds

Clone	The age of cocoa seeds (weeks)									
	1	2	3	4	5	6	7	8	9	10
	ng.g ⁻¹ fresh weight									
KW 163	1068.10	740.68	577.99	394.11	340.43	264.49	261.42	200.02	219.31	181.92
KW 165	1762.49	1946.69	1394.62	984.19	616.86	730.39	751.20	730.69	718.92	714.54

Table 2. The purity and concentration of RNA in the cocoa seeds

Clone	RNA concentration ($\mu\text{g.ml}^{-1}$)	RNA purity
KW 163	82	1.9
KW 165	66	2.0

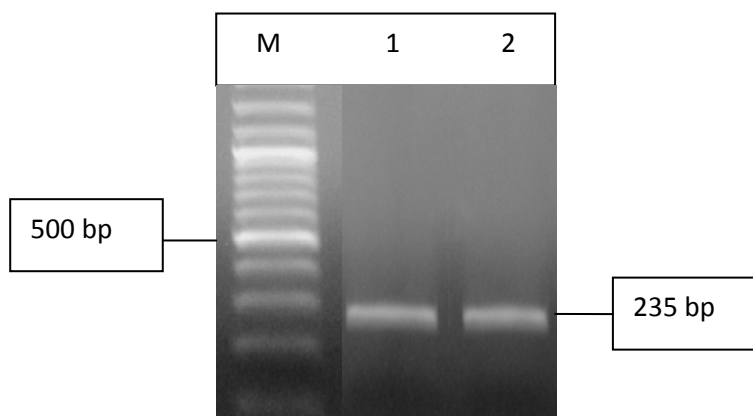

Fig. 1. RT-PCR product electrophoregram of *TcGA20ox* like gene from RNA of 7 weeks cocoa seeds. M. 100 bp DNA marker (Vivantis); 1. KW163; 2. KW165.

The result of the isolation *TcGA20ox* like gene expression is consistent with the result of the content of gibberellic acid (Table 1). Gibberellic acid biosynthesis in seeds is also indicated by the relatively high content of gibberellic acid in seeds, which is between 1068.10 - 1762.49 ng.g⁻¹ fresh weight of seeds aged 1 weeks until about 181.92 - 714.54 ng.g⁻¹ fresh weight of seeds aged 10 weeks (Table 1). Gibberellic acid content in the young seeds is much higher than in the older, indicating a strong gibberellic acid synthesis in the young seeds. This is supported by the electrophoregram of *TcGA20ox* like gene expression. The gibberellic acid synthesis is required for embryonic development. Gene expression analysis performed in this study reinforced the role of gibberellic acid in the development of cocoa seeds. Photosynthate allocation is an integrated system, which is determined by the interaction between the source and sink. Changes in sink activity would affect changes in photosynthate transport toward

the sink. Sink activity is a metabolic activity in the sink, such as respiration process and maintenance processes for the formation, growth and development (Pearcy *et al.*, 1994). Cell metabolism is regulated by various of hormones interactively. Gibberellic acid content analysis showed that there were changes in the gibberellic acid content of cocoa seed development. This could be an indicator of the gibberellic acid effect on the development of cocoa seeds. It is in accordance with the statement that there is a role of gibberellic acid in the tissue development (Frigerio *et al.*, 2006). The result indicates a characteristic of gibberellic acid content at each stage of the development of cocoa seeds. Gibberellic acid with other hormones regulate metabolism in seeds and determine the process of embryogenesis and viability of seed development. This result is consistent with the statement that auxin and gibberellic acid increase the sink strength of the fruit to absorb photosynthate in cocoa (Miller & Walsh, 1990) and *Festuca rubra* L. (Hull, 1996). The presence of hormones in the fruit is determined by its biosynthesis and transport. Gibberellic acid biosynthesis takes place in several stages involving various reactions. *TcGA20ox* like gene expression is found in seeds revealed the presence of gibberellic acid biosynthesis in seed that is required for embryonic development. This study revealed the possible role of gibberellic acid synthesis in the development of cocoa seeds.

CONCLUSION

Gibberellic acid found in cocoa seeds reveals the role of gibberellic acid on each stage of the development of cocoa seeds. *TcGA20ox* like gene expression found in cocoa seeds indicates gibberellic acid synthesis in the seeds which determines the success of the development of cocoa seeds.

REFERENCES

- Ait-Ali, TA, Frances, S, Weller, JL, Reid, JB, Kendrick, RE & Kamiya, Y 1999, 'Regulation of gibberellin 20-oxidase and gibberellin 3 β -hydroxylase transcript accumulation during de-etiolation of pea seedlings', *Plant Physiol.*, vol. 121, pp. 783-791.
- Almeida, AF & Valle, RR 2007, 'Ecophysiology of the cacao tree', *Braz. J. Plant Physiol.*, vol.19 no.4, pp. 425-448.
- Baydar, NG & Harmankaya, N 2004, 'Changes in endogenous hormone levels during the ripening of grape cultivars having different berry set mechanisms', *Turk. J. Agric. For.*, vol. 29, pp. 205-210.
- Blumenfeld, A 1970, *Hormonal Systems in Avocado Fruits*. PhD Thesis, The Hebrew Univ. of Jerusalem, Jerusalem.
- Bower, JP & Cutting, JG 1988, 'Avocado fruit development and ripening physiology', in Janick, J (*ed.*), *Hort. rev.*, vol. 10, pp. 229-271.
- Buckhout, T & Tubbe, A 1996, 'Structure, mechanisms of catalysis, and regulation of sugar transporters in plants', in Zamski, E & Schaffer, AA (*eds.*), *Photoassimilate Distribution in Plants and Crops: Source – sink Relationships*, Marcel Dekker Inc., New York, pp. 229-282.

- Cuatrecasas, J 1964, *Cacao and Its Allies: A Taxonomic Revision of The Genus Theobroma*, Smithsonian Institution, Washington D.C.
- Flores, LP, Carrari, F, Fernandez, RO, Rodriguez, MV, Ensico, S, Stanelloni, R, Sanchez, RA, Bottini, R, Lusem, ND & Arnold, RLB 2003, 'Expression analysis of a GA 20-oxidase in embryos from two sorghum lines with contrasting dormancy: Possible participation of this gene in the hormonal control of germination', *J. of Exp. Bot.*, vol. 54, no. 390, pp. 2071-2079.
- Frigerio, M, Alabadi, D, Gomez, JP, Carcel, LG, Phillips, AL, Hedden, P & Blazquez, MA 2006, 'Transcriptional regulation of gibberellin metabolism genes by auxin signaling in *Arabidopsis*', *Plant Physiol.* vol.142, pp. 553-563.
- Gillaspy, G, Ben-David, H & Gruissem, W, 1993, 'Fruits: A developmental perspective', *The Plant Cell*, vol. 5, pp. 1439-1451.
- Grierson, W 1995, 'Fruit development, maturation, and ripening', in Pessarakli, M (*ed.*), *Handbook of Plant and Crop Physiology*, Marcel Dekker Inc., New York, pp. 419-425.
- Hasenstein, KH & Zavada, MS 2001, 'Auxin modification of the incompatibility response in *Theobroma cacao*', *Phys. Plant*, vol. 112, pp. 113-118.
- Ho, LC 1996, 'Whole plant source – sink relationships of selected crops: tomato', in Zamski, E & Schaffer, AA (*eds.*), *Photoassimilate Distribution in Plants and Crops: Source – sink Relationships*, Marcel Dekker Inc., New York, pp. 709-728.
- Hu, J, Mitchum, MG, Barnaby, N, Ayele, BA, Ogawa, M, Nam, E, Lai, WC, Hanada, A, Alonso, JM, Ecker, JR, Swain, SM, Yamaguchi, S, Kamiya, Y & Sun, TP 2008, 'Potential sites of bioactive gibberellin production during reproductive growth in *Arabidopsis*', *The Plant Cell*, vol. 20, pp. 320-336.
- Huizen, R, Ozga, A & Reinecke, DM 1997, 'Seed and hormonal regulation of gibberellin 20-oxidase expression in pea pericarp', *Plant Physiol.*, vol. 115, pp. 123-128.
- Hull, RJ 1996. 'Whole plant source – sink relationships of selected crops: turfgrasses', in Zamski, E & Schaffer, AA (*eds.*), *Photoassimilate Distribution in Plants and Crops: Source – sink Relationships*, Marcel Dekker Inc., New York, pp. 781-796.
- Kelen, M, Demiralay, EQ, Ser, S & Ozkan, G 2004, 'Separation of abscisic acid, indole-3-acetic acid, gibberellic acid in 99 R (*Vitis berlandieri* x *Vitis rupestris*) and Rose oil (*Rosa damascene* Mill.) by reversed phase liquid chromatography', *Turk. J. Chem.*, vol. 28, pp. 603-610.
- Kojima, K 2005, 'Phytohormones in shoot and fruits of tomato: apoplast solution and seedless fruit', *JARQ*, vol. 39, no. 2, pp. 77-81.
- Kusaba, S, Honda, C & Kano-Murakami, Y 2001, 'Isolation and expression analysis of gibberellin 20-oxidase homologous gene in apple', *J. of Exp. Bot.*, vol. 52, no. 355, pp. 375-376.
- Liu, F, Jensen, CR & Andersen, MN 2004, 'Pod set related to photosynthetic rate and endogenous ABA in soybeans subjected to different water regimes and

- exogenous ABA and BA at early reproductive stages', *Ann. of Bot.*, vol. 94, pp. 405-411.
- Miller, AN & Walsh, CS 1990, 'Indole-3-acetic acid concentration and ethylene evolution during early fruit drop development in peach', *Plant Growth Regul.*, vol. 9, pp. 37-46.
- Nichols, R 1960, 'Auxins of cacao and cherelle wilt', *Proc. VII Interamericana Cacao Conference*, Trinidad and Tobago, pp. 100 – 104.
- Olszewski, N, Sun, T & Gubler, F 2002, 'Gibberellin signaling: biosynthesis, catabolism, and response pathways', *The Plant Cell*, vol. 14, pp. 61-80.
- Ozga, JA, Reiecke, DM, Ayele, BT, Ngo, P, Nadeau, C & Wickramarathna, AD 2009, 'Developmental and hormonal regulation of gibberellin biosynthesis and catabolism in pea fruit', *Plant Physiol.*, vol. 150, pp. 448-462.
- Pearcy, RW, Ehleringer, JR, Mooney, HA & Rundel, PW 1994, *Plant Physiological Ecology*, Chapman & Hall, London.
- Phillips, AL, Ward, DA, Uknes, S, Appleford, NEJ, Lange, T, Huttly, AK, Gaskin, P, Graebe, JE & Hedden, P 1995, 'Isolation and expression of three gibberellin 20-oxidase cDNA clones from *Arabidopsis*', *Plant Physiol.*, vol. 108, pp. 1049-1057.
- Prawoto, AA 2000, 'Kajian morfologis, anatomis dan biokhemis layu pentil kakao serta perkembangan upaya pengendaliannya', *Pelita Perkebunan*, vol. 16, no. 1, pp. 11-29.
- Rademacher, W 2000, 'Growth retardants: effects on gibberellin biosynthesis and other metabolic pathways', *Ann. Rev. Plant Physiol. Plant Mol. Biol.*, vol. 51, pp. 501-531.
- Ramsperger-Gleixner, M, Geiger, D, Hedrich, R & Sauer, N 2004, 'Differential expression of sucrose transporter and polyol transporter genes during maturation of common plant in companion cells', *Plant Physiol.*, vol. 134, pp. 147-160.
- Richards, D.E, King, KE, Ait-Ali, T & Harbed, NP 2001, 'How gibberellin regulates plant growth and development: A molecular genetic analysis of gibberellin signaling', *Ann. Rev. Plant Physiol. and Mol. Biol.*, vol. 52, pp. 67-88.
- Rock, CD & Quatrano, RS 1995, 'The role of hormones during seed development. Metabolism', in Davies, PJ (ed.), *Plant Hormones; Physiology, Biochemistry and Molecular Biology*, Kluwer Acad. Publ., London, pp. 671-697.
- Sponsel, VM 1995, 'The biosynthesis and metabolism of gibberellins in higher plants metabolism', in Davies, PJ (ed.), *Plant Hormones; Physiology, Biochemistry and Molecular Biology*, Kluwer Acad. Publ., London, pp. 66-97.
- Thorpe, MR & Minchin, PEH 1996, 'Mechanisms of long- and short- distance transport from sources to sinks', in Zamski, E & Schaffer, AA (eds.), *Photoassimilate Distribution in Plants and Crops: Source – sink Relationships*, Marcel Dekker Inc., New York, pp. 261-282.

- Turgeon, R 2006, 'Phloem loading: How leaves gain their independence', *BioSci.*, vol. 56, no. 1, pp. 15-24.
- Wei-guo, F, Hua-ming, A, Guo-qin, L, Song-tao, H & Jin-ping, L 2004, 'Changes of endogenous hormones contents in fruit, seeds and their effects on fruit development of *Rosa roxburghii*', *Sci. Agric. Sinice*, vol. 37, no. 5, pp. 728-733.
- Weiss, D & Ori, N 2007, 'Mechanisms of cross talk between gibberellin and other hormones', *Plant Physiol.*, vol. 144, pp. 1240-1246.
- Wood, GAR & Lass, RA 1985, *Cocoa*, Longman, London.

ALTERNATIVE PROPAGATION TECHNOLOGY FOR RUBBER (*Hevea brasiliensis*)

Onofre S. Corpuz

Arakan Cotabato Foundation College of Science and Technology PHILIPPINES

nfr_uplb@yahoo.com

ABSTRACT

Rubber tree is known to be the white gold tree species in Mindanao Philippines due to its high priced latex product. It is a seasonal tree which has problems on seed propagation thus; stem cut rubber was tested for sprouting and rooting potentials as affected by stem parts and levels of ANAA. The experiment employed a split-split plot design in lay-out and data analysis. The results indicated that at 75 days of observation, brown stem cut rubber significantly gave higher rate of survival (74%) as compared to 41% in green stem cut. No ANAA (control treatment) was significantly lower in survival rate of 48.3% compared with 65.8% and 58.3% in 1tbsp/3 lit. H₂O and 1tbsp/1lit. H₂O respectively with no interaction effects observed. Brown stem part significantly performed better than the young stem parts (green stem cut) as affected by the levels of ANAA. Lower concentration of ANAA (1tbsp/3 lit. H₂O) gives better sprouts and rooting potentials as compared to the control treatment and higher concentration of the growth hormone with interaction effects. This indicated that older stem part and lower level of ANAA application would mean greater potential of propagating rubber tree through stem cut technology, thus alternative propagation technology during seed off year in rubber would be addressed.

Keywords: *Stem cut, sprout, rooting potentials, survival rate, soaking time, levels of ANAA*

INTRODUCTION

The common rubber (*Hevea brasiliensis*) tree is an indigenous tree in Amazon, Brazil. It is a tropical tree that grows best at temperatures of 20-28°C with annual rainfall of 1,800-2000 mm. Prime growing area of rubber tree is 10 degrees in latitudes from the equator, but it is also cultivated in the Philippines particularly in Mindanao Island. It is a light demanding tree species and requires moist soil. Rubber tree is relatively insensitive to soil type, but higher production and disease resistance can be on highly fertile soil.

H. brasiliensis grows satisfactorily up to 600 meters asl, but it tends to be pruned to damage by strong winds. In plantations, it may grow up to 20 to 30 meters (IRRDB, 2005). It is a material having industrial, technologies and domestic uses. While it is considered a minor crop in the Philippines, it has high export potentials and is rated as one of the most profitable agro-industrial ventures (Phil. Recommend for Rubber, 1977).

Rubber tree is initially grown for its latex but it provided timber for the highly profitable downstream furniture industry (Mohamad, 1998). It is a seasonal tree species which

means that there are years when said plant do not bear fruits (seed-off year). With this reason, rubber nurserymen/planters could hardly provide means of producing planting materials. Hence, this research attempts to find alternative methods of mass propagation of rubber planting materials by trying to determine the growth success of stem cut rubber as influence by stem parts and levels of ANAA. Vegetative propagation provides the best opportunity to multiply valuable trees for cultivation (Mialoundama *et al.*, 2002. Results of this study may help rubber planters and nurserymen to cope with the shortage of rubber planting materials during off seasons.

Seedlings of *H. brasiliensis* are raised in nursery for almost a year before transplanting to the field. Stem cut propagation technology for rubber tree will shorten this time of nursery management besides, it help minimize cost and effort of producing planting materials by utilizing tree parts in mass propagation during seed-off year or even during peak season of rubber trees by recycling/utilizing the stems being cut after budding successes. Result of this study will contribute on the development of the rural community rubber farmers/planters who cannot afford to buy high cost budded rubber planting materials. It is assured that stem cut will inherit all the characteristics of the tree source (prototype) thus, successful stem cut propagules will not be budded anymore.

The study generally aimed to propagate rubber tree through stem cut. Specifically it sought to:

1. Determine the sprouting and rooting potentials of stem cut rubber as influence by stem parts (brown and green) and levels of alpha naphthalene acetic acid (ANAA).
2. Find out the survival rate of the stem cut rubber
3. Determine the number of roots that will be developed
4. Measure the length of the sprout and longest root developed
5. Relate the rates of the growth hormones with the growth characteristics that appears such as number of stem that produces sprouts, number of roots develop, length of sprout and longest roots developed

MATERIAL AND METHOD

Study on the success of stem cut rubber as alternative propagation technology was conducted in CFCST Doroluman Arakan Cotabato from July 17 to October 2, 2011 to determine the potential of stem cut rubber tree in producing sprouts and roots. One hundred eighty stem cut (green and brown stem) at 1foot length (Figure 1) were used in the study. Stem cut were soak in water with ANAA at different levels such as 1tbsp/litH₂O and 1tbsp/3litH₂O including control treatment (no application). After soaking at decided number of hours (0 hours as control, 6 hours and 12 hours treatment), stem cut were planted on a used poly bag soil filled with sandy clay soil with a ratio of 1:2. The experiment is arranged in a split-split plot design using stem parts as main plot treatment, soaking time as subplot and levels of ANAA as sub-subplot treatment replicated three times. The data were analyzed using SAS version 5.



Figure 1. Stem cut rubber parts

RESULT AND DISCUSSION

A. Survival Rate

Table 1 shows that at 75 days of observation, brown cut rubber significantly has higher survival rate of 74% as compared to 41% in green cut stem parts. The levels of ANAA also shows significant variations. The control treatment is significantly lower in survival (48.3%) compared with 65.8% and 58.3% in 1tbsp/3 lit. H₂O and 1tbsp/1lit. H₂O respectively. Figure 3 shows the cuttings in 75days after planting.

Table 1. Survival of stem cut rubber after 75 days as affected by stem parts and levels of ANAA

Parameters	Treatment	Percent
Stem Parts	Green	40.67a
	Brown	74.00b
Levels of ANAA	No Application	48.30a
	1tbsp/1lit.H ₂ O	58.30ab
	1tbsp/3lit.H ₂ O	65.80b

Mean with common letter subscript are not significantly different at 1% level



Figure 3. The cuttings in 75days after planting

B. Sprouting

The stem cut parts in 17 days after planting reported to significantly **affects** sprouting growth. The green stem parts significantly performed better compared to brown stem parts in the early growth stage. However, after 45 days to 75 days, the trend reversed, brown stem parts significantly performed better than the green stem (Table 2). Figure 4 and figure 5 shows the stem cut after 17 and 45 days respectively.

Table 2. Sprouting growth potentials of stem cut rubber as affected by stem parts

Stem Parts	17 Days	45 Days	60 Days	75 Days
Green	6.2667a	5.8000a	5.0000a	4.0667a
Brown	3.8000b	8.0667b	7.4667b	7.4000b

Mean with common letter subscript are not significantly different at 1% level



Figure 4. 17 days after planting



Figure 5. 45 days after planting

Levels of ANAA significantly **affects** sprouting success. At 17 days, the control treatment (no application) significantly lower in growth (3.083 sprouts) compared to 5 and 7 sprouts in 1tbsp/lit.H₂O and 1tbsp/3lit.H₂O respectively. The trend continued up to 75 days only that the control treatment did not significantly **varied** with 1tbsp/lit.H₂O (Table 3).

Table 3. Sprouting growth potentials of stem cut rubber as affected by levels of ANAA

Levels of ANAA	17 Days	45 Days	60 Days	75 Days
Control	3.083a	6.083a	5.167a	4.83a
1tbsp/lit.H ₂ O	5.000b	7.500b	7.250b	5.83ab
1tbsp/3lit.H ₂ O	7.000b	7.500b	6.330ab	6.58b

Mean with common letter subscript are not significantly different at 1% level

C. Length of sprout produced

Table 4 shows the length of sprout measured after 75 days. The brown stem part reported to be significantly longer in length of 12.7cm compared to the green parts of only 5.76cm. This implies that brown stem cut grows faster in length up to 75 days (Table 4).

In terms of the effect of ANAA on sprout length, the two treatments did not vary significantly with the control treatment. This implies that the level of ANAA did not affect the growth of sprout in terms of length.

Table 4. Length of sprout measured after 75 days as affected by stem parts and levels of ANAA

Parameters	Treatment	Mean
Stem Parts	Green	5.7644a
	Brown	12.700b
Levels of ANAA	No Application	9.733a
	1tbsp/1lit.H ₂ O	9.436a
	1tbsp/3lit.H ₂ O	8.778a

Mean with common letter subscript are not significantly different at 1% level

D. Rooting Growth Potentials

The number of roots developed did not vary as influenced by stem parts. However, root length and number of secondary roots significantly differed. The brown stem cut significantly longer in length (6.67cm) compared to 4.65cm in green stem cut (Table 5).

Brown stem cut also significantly higher in number of secondary roots developed (8.95) compared to only 5.4 in green stem cut.

Table 5. Rooting growth potentials of stem cut rubber as affected by stem parts

Stem Parts	No.of Roots	Length of Root (cm)	No. of Secondary Roots
Green	2.0	4.65a	5.4a
Brown	2.24	6.66b	8.95b

Means with the same letter are not significantly varied at 5% level

The effect of ANAA levels on the root growth of stem cut rubber is reported to be significant in terms of number of roots and length of roots but not to number of secondary roots. The 1tbsp/3lit.H₂O has significantly higher number of roots developed (4.4) and has longer roots (9.125cm) compared to the 1tbsp/lit.H₂O and the control treatment which are not significantly varied from each other (Table 6). Figure 6 shows the uprooted plants with root system and sprouts developed.

Table 6. Rooting potentials of stem cut rubber as affected by levels of ANAA

Levels of ANAA	No.of Roots	Length of Root (cm)	No.of Secondary Roots
No Application	2.22a	7.389a	7.286a
1tbsp/1lit.H ₂ O	2.84a	7.632a	8.867a
1tbsp/3lit.H ₂ O	4.4b	9.544b	9.125a

Mean with the same letter subscript are not significantly different at 5%



Figure 6. Uprooted plants with root system and sprouts developed

E. Effect of soaking time

No significant effect have been observed in the survival rate, sprouting and rooting potentials of stem cut rubber as influenced by time of soaking. This implies that soaking hours will not affects the growth success of stem cut rubber.

F. Relationship of the number of sprout developed per collection days with stem parts, levels of ANAA and time of soaking

Pearson's correlation analysis reported that cut stem parts of the rubber is negatively related to the number of sprouts emerged 45 days after planting (DAP), 60 DAP and 75 DAP. The same findings with the levels of ANAA was found (Table 11).

On the other hand, time of soaking is positively related with the number of sprouts emerged in all collection days. The implication of the negative relationship in the levels of ANAA with number of sprouts emerged can be due to over dosage. As the level of ANAA application increased, growth of sprout seems to decline. The finding of the study clearly state that 1tbsp/3litH₂O is significantly better than 1tbsp/litH₂O in terms of sprout and root growth potentials of rubber tree species.

Table 11. Pearsons' Correlation Analysis for stem parts, levels of ANAA, soaking time and number of sprouts emerged in various collection days after planting

	Stem Parts	ANAA Level	Soaking Time	17 DAP	45 DAP	60 DAP	75 DAP
Stem Parts	1.0000						
ANAA level	0.0000	1.0000					
Soaking time	0.0000	0.6429**	1.0000				
17 DAP	0.4134*	-0.3554	0.0329	1.0000			
45 DAP	-0.4553*	-0.0608	0.1181	0.0946	1.0000		
60 DAP	-0.050**	-0.2113	0.0255	0.1406	0.6926**	1.0000	
75 DAP	-0.627**	-0.1609	0.0905	0.0516	0.7230**	0.8201**	1.000

G. Scatter plot of the relationships of stem parts, levels of ANAA and time of soaking

The following scatter plots will explain the relationship of the three factors (stem parts, soaking time and rate of ANAA) with sprouting and rooting growth of stem cut rubber.

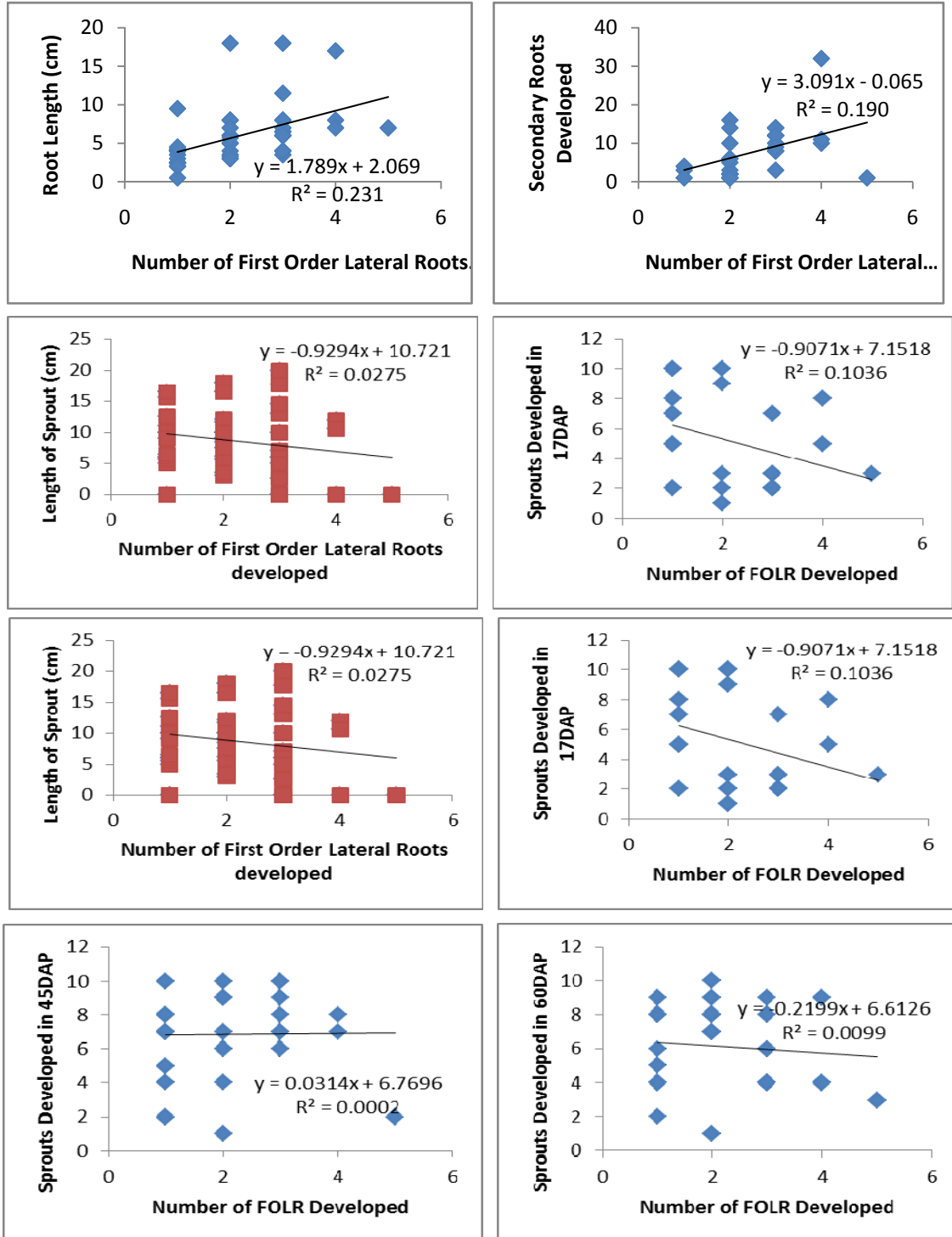

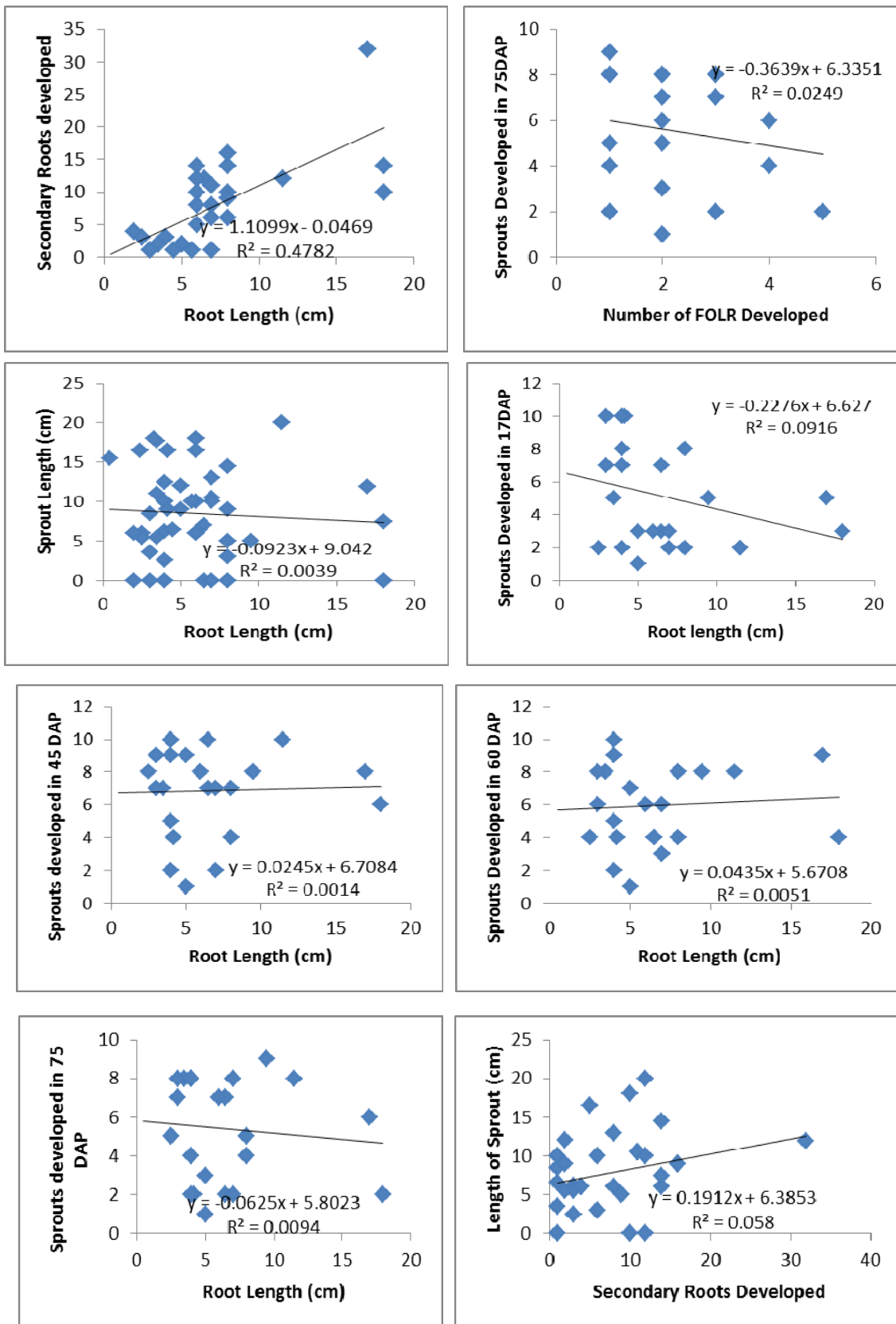

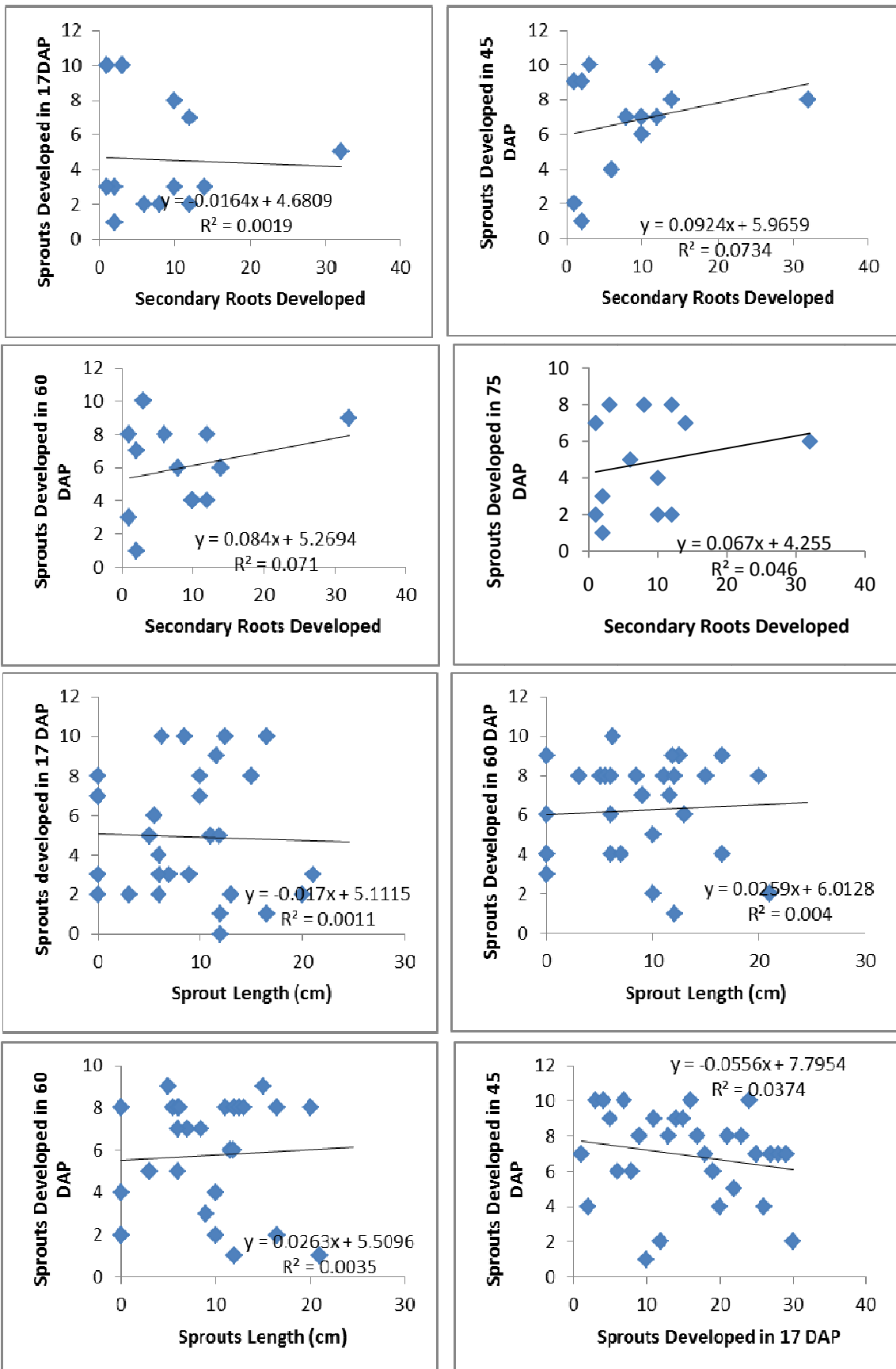

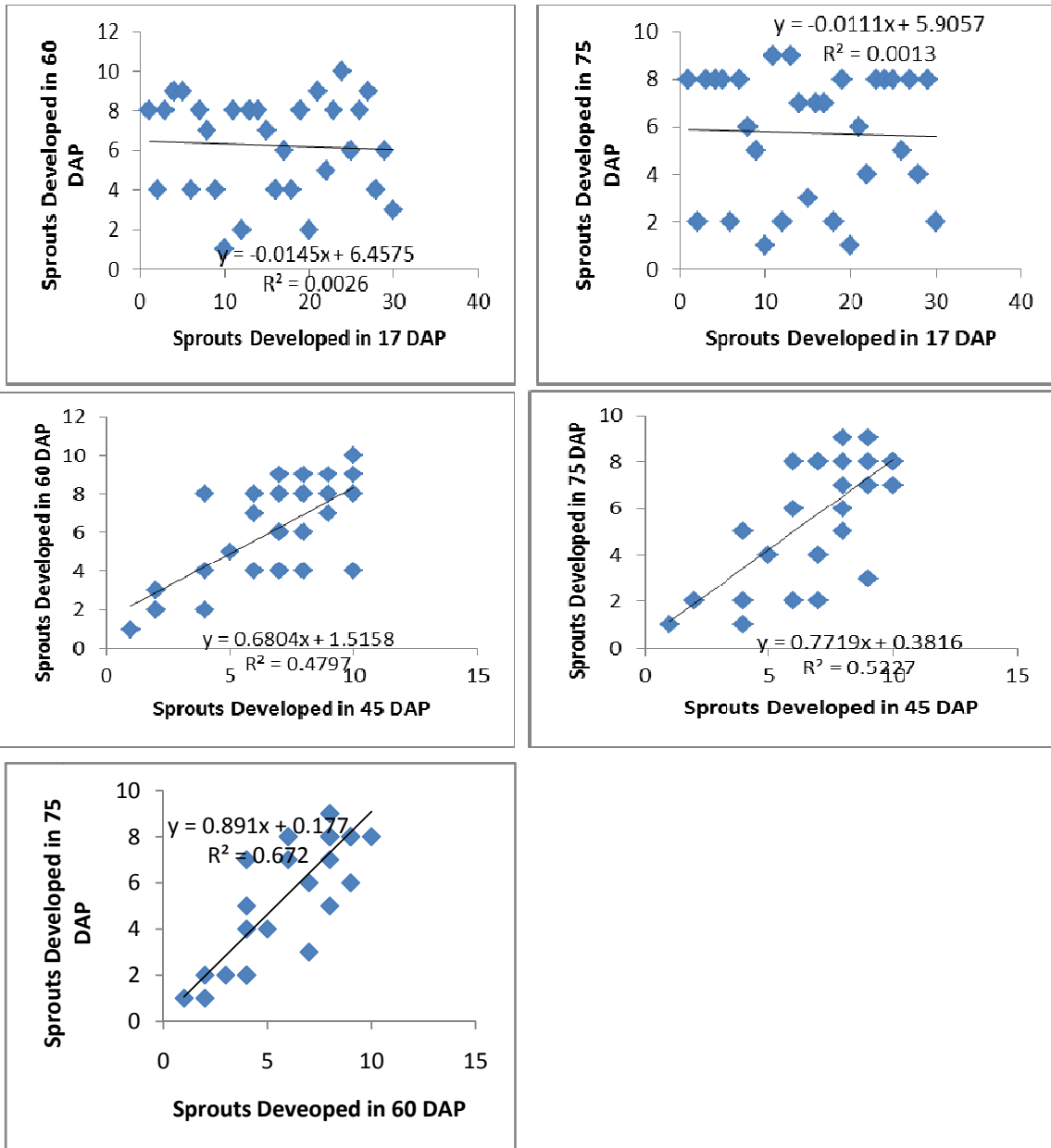

The length of rubber stem cut used in the study is 1 foot in length without considering the visible bud eye of the stems. One study shows that single node stem cuttings are better planting materials for successful survival and of large plum. There could be differences in aeration between media; or even the pH of the media. Small responses of large sour plum cuttings to hormone application could be due to high supplements of endogenous auxins in the shoots of the cuttings and these might interact negatively with the applied NAA hormones (Owuor et.al 2009).

Rooting ability of stem cuttings depends on several factors. The purpose of treating the cuttings, with auxin is to increase the percentage of rooting (Ullah *et al.*, 2005). Rooting was relatively insensitive to different NAA concentrations. The good rooting and survival of cuttings in sawdust may be explained by the high water retention of sawdust (Mialondou *et al.*, 2002) and faster initiation of root formation by NAA hormone application. With the present study, 1tbsp/3litH₂O survived significantly and performed

better as compared to 1tbsp/litH₂O. Among the exogenous rooting hormones, alpha naphthalene acetic acid (ANAA) has been found to be reliable in rooting of cuttings. According to Hartmann *et al.*, (1997) there are compounds within stem cuttings such as phenolics that interact with auxins to promote rooting, and increase root length. Some species tend to root better in certain substrates with or without hormone treatment, and this is linked to their hydromorphic or xeromorphic status (Mialondou *et al.*, 2002).

The findings of Blythe *et. al* (undated) generally showed that, with increasing auxin concentration in the plugs, treatments first provided a root-promoting response of the lower stem tissue of the cuttings and suppression of shoot development, then a phytotoxic response of the lower stem tissue and some root-promoting response of the upper stem tissue, and then a phytotoxic response by all stem tissue. The auxin NAA has previously been shown to be phytotoxic when applied at elevated rates to *Oxalis* plants as a foliar spray (Holt and Chism, 1988).

Vegetative propagation provides the best opportunity to multiply valuable trees for cultivation (Mialoundama *et al.*, 2002). Cuttings propagated in sawdust with hormone treatment produced long and slender roots (Owuor *et.al* 2009). Application of ANAA hormone tended to increase the rate of root growth. Similar findings were reported by Ofori *et al.* (1996) while rooting *Milicia excelsa*. Other factors could interact with media to affect root growth and development (Loach, 1992). Roots of the cuttings grown in sand media were short, coarse and brittle, while when media such as mixture of sand: sawdust were used, the cuttings had well branched “slender” and flexible root types, which were suitable for transplanting. The findings also agree well with the findings by Hartmann and Kester (1983). The observations could be explained by the high moisture holding capacity and good aeration of the sawdust media. Pure sawdust has been found to have high moisture holding capacity and also a lower air/water ratio than coarse and fine sand in the propagation of *Nauclea diderrichii* cuttings (Leakey,1990).

Accordingly to Mohinderpal (1995), 1000 ppm of IBA treatment applied as basal dip in 1-2 cm diameter hardwood cuttings collected from healthy vigorously growing branches where in terminal portion of leaves is excised and branches are made into 15-20 cm long cuttings and then planted in nursery beds under 50-60% shade. The per cent of rooting is low.

On the other hand, hardwood cuttings treated with IAA or IBA 100 ppm in dilute water solution by basal dip method for 24 hrs gave profuse rooting (Sunil Puri and Verma, 1996).

Researchers have proved that stem cuttings of chirpine can be rooted with the help of auxin under mist conditions (Bhatnagar, 1977). About 12-15 cm long cuttings taken from the lateral branches of six year old plants of chirpine in the month of July, treated with 50 mg/l-1 water solution of IAA and planted under mist are reported to root 100% (Shamet and Handa, 1996). To encourage growth of branch blasts, the apical portion of chirpine plants is excised in the beginning of April. Within a month, about 4-6 cm long branch blasts are produced near the cut end. These are collected and planted under mist. Rooting occurs on more than 60 per cent cuttings within about 6 weeks. The percentage of rooted cuttings can be increased to as high as 90 per cent by girdling the side shoots followed by the treatment with growth promoters, and using these side shoots for vegetative propagation.

CONCLUSION

Based from the result of the study, sprouting and rooting success of stem cut rubber particularly the brown/older part performed and survived significantly better and higher with the green/younger stem parts. While lower concentration of ANAA (1tbsp/3lit.H₂O) perform better as compared to the control treatment. Time of soaking did not affect the sprouting and rooting growth of stem cut rubber. These findings can be used as guide when propagating rubber trees through stem cut.

Stem cut technology for rubber tree would be an advantaged for rubber farmers to continuesly cultivate planting materials even during seed off year thus promote sustainability aside from the benefits of shortening the nursery management time from 6-9 months to a petriod of only 3-6 months. Budding operation as pre-requesit for rubber plantation using sexual propagation would not a problem when using asexually propagated planting materials as in this particular findings.

RECOMENDATION

Testing of other growth hormones should be done to better understand their effects. The foregoing study only proves that older stem cut rubber performed better than green or younger parts. It also proves that lower concentration of ANAA (1tbsp/3litH₂O) responded better than higher concentrations of 1tbsp/litH₂O.

This finding will be further validated when conducting another trials with additional parameters and treatments such as different watering frequency, varied temperature of shading intensity, soil medium, length of cuttings, varietal source, other growth hormones, time of collecting cuttings, position of planting, and age of tree source. Take note that, plant grown through cuttings would be genetically identical to the parent plant from which the original cutting was taken. This is not necessarily so when plants are grown from seed. Cuttings are the most widely used technique for reproducing "prototype" plants. Therefore, it is highly recommended to have a follow up study and test the on field performance of successful cuttings in the particular study considering its growth and latex production.

REFERENCES

- Blyth, E.K, Sibley J.M.,. Tilt, K.M 2004. Cutting propagation of foliage crops using a foliar application of auxin. *Scientia Hort.* 103:1:31-37.
- Hartmann, H.T., D.E. Kester, F.T. Davies, Jr., and R.L. Geneve. 2002. *Plant propagation: Principles and practices.* 7th ed. Prentice Hall, Upper Saddle River, NewJersey.
- Hartmann, H.T. and Kester D.E. 1983. *Plant propagation, rinciples and practices.* Prentice Hall International, London.
- Holt, J.S. and W.J. Chism. 1988. Herbicidal activity of NAA (1-naphthaleneacetic acid) on creeping woodsorrel (*Oxalis corniculata*) in ornamentals. *Weed Sci.* 36:227-233.

- IRRDB 2005. The International Rubber Research and Development Board. Proceedings of Symposium on physiological and molecular aspects of the breeding of Hevea
- Leakey R.R.B. 1990. *Nauclea diderriochi*: rooting of stem cuttings, clonal variation in shoot dominance, and branch plagiotropism. *Trees*. 4:164-169.
- Mialoundama F., M.L. Avana, E. Youmbi, P.C. Mampouyl, F. Kogpuep, A.C. Tsobeng, and J. Abega 2002. Vegetative propagation of *Dcrodos edulis* (G. Don) H.J Lam by marcots, cuttings and micropropagation. *Forests, Tress and Livelihoods*. 12:85-96
- Ofori, D.A., A.C. Newton, R.R.B. Leakey, and J. Grace. 1996. Vegetative propagation of *Milicia excels* by leafy stem cuttings: effects of auxin concentration, leaf area and rooting medium. *For ecology Mgt*. 84:39-48.
- Owuor, B. , D. Musyimi, M. Ocaidoand J. Asimwe. 2009. Vegetative propagation of the large sour plum (*Ximenia caffra* Sond) by rooting of plagiotropic stem cutting. *ARPN Journal of Agricultural and Biological Science*. Vol 4. No. 1 January 2009.
- Sunil Puri and S.L. Swamy. Geographical variation in rooting ability of stem cuttings of *Azadirachta indica* and *Dalbergia sisso*. *Genetic Resource and Crop Evolution*. Vol. 46 No. 1, 29-36, DOI 10.1023/A:1008609407987. <http://springerlink>.
- Ullah, T., F.U. Wazir, M. Ahmad, F. Analoui, and M.U. Khan. 2005. A break through in guava (*Psidium guajava* L.) propagation from cutting. *Asian Journal Plant Sci.*, 4:238-243.

TESTING AND EVALUATION OF UPLAND RICE VARIETIES IN SULTAN KUDARAT PROVINCE

R. Ortuoste ¹ and, J. Ortuoste ²

Environmental Management, 2 Planning and International Affairs

Sultan Kudarat State University

susanortuoste@gmail.com

ABSTRACT

A study was conducted in Senator Ninoy Aquino and Bagumbayan, Sultan Kudarat. For six (6) consecutive wet and dry cropping seasons from May 2008 to November 2011 to determine the agronomic and yield characteristics and its reaction to pests and diseases. Results showed that on the average yield of the different upland rice cultivars in six cropping seasons, Kasagpi, Kulaman and Bli outyielded the check with a mean yield of 2717,2675 and 2555 kg/ha, respectively. In terms of the agronomic characteristics, all indigenous varieties exhibited similar characteristics on the average number of productive tillers and filled grains. However in terms of plant height almost all indigenous cultivars were taller and are late maturing as compared to the check (UPL Ri 5, UPL Ri 7 and NSIC varieties). In terms of its reaction to pests and diseases, Kulaman cultivars were severely damaged with rice blast during dry season.

Keywords: *Upland rice, cultivars, outyielded, productive tillers and maturity.*

INTRODUCTION

Historically, farmers play an important role in the development of crops. The first breeders were the farmers who domesticated wild plants that resulted to the cultivated crops being grown today like upland rice.

Upland rice is noted for its quality and aromatic flavor which is highly demanded as source of carbohydrates specifically for the Filipinos. This is usually served during special occasions where family and friends dine in together. Demands of these varieties are high in the market and commands higher price as compared to the lowland rice varieties. In spite of this situation, rarely we can see farmers planting the said cultivars due to limited or unavailable seed supply coupled with its susceptibility to pests and diseases and high production cost.

With only few approved released varieties available to farmers, they continue to select new varieties/cultivars that will suit to their needs and preferences that can adapt to local conditions.

With the desire to increase and sustain rice production in the country, there is a need to continuously develop new and improved upland rice cultivars. However, before a new upland rice cultivar is recommended to the farmers for commercial planting, there is a

need to conduct multi-location season trials in order to determine their yield potentials and its reaction to pest and diseases.

It is on these premise that this study was conducted to collect available seeds from the farmers in the province and in the neighboring provinces and to test its adaptability through performance evaluation in terms of its agronomic characteristics and yielding ability. High performing and high yielding varieties will be screened further to test its resistance to pest and diseases. Results of this study will be made as one of the bases in deciding what upland rice cultivars is suitable in the province of Sultan Kudarat

OBJECTIVES

1. To determine the agronomic characteristics and yielding ability of different upland rice varieties collected in the province of Sultan Kudarat
2. To evaluate the field reaction of the different upland rice varieties to major rice pest and diseases
3. To mass produce selected lines/varieties for commercial production

REVIEW OF RELATED LITERATURE

A research-farmer managed trial was constructed in highland area of Cotabato provinces from April to August 1995. Three Farmer cooperators were requested to set aside 5,000sqm used to test the different upland rice varieties. Six upland rice varieties were superimposed in the farmer field. Among the different varieties tested, UPL Ri-7 has the highest yield of 3.83 tons per hectare followed by PSB RC-I, UPL Ri-S1, C4-68g, C4-137 and BPI-76 with a mean of 3.67, 3.56, 3.52, 3.40 tons per hectare respectively. The harvest was obtained by Dinorado farmers variety with a mean of 1.82 tons per hectare.

Nine upland rice selection, one Philippine seed board (PSB) upland rice variety and a popularity grown farmers variety were evaluated for adaptation quality in acid upland areas of cavity, Iloilo, Negros Occidental and Bukidnon with varying degrees of acidity. Adaptation trials aimed to evaluate cultivars in terms of higher yield, more tolerance to acidity and other associated soil disorders, resistance to pest and comparable grain qualities with the currently grown rice cultivars in the area. Only the selection IR 3880-2-3 ad IR 2979-24-1 (brown) obtained higher mean yield than the check variety IR3880-2-3 yielded more than 2,000kg/ha or 86%.

Upland rice refers to rice grown both in levels and stopping fields that are bounded and depend in rainfall for moisture (De Datta, 1975). Likewise shifting cultivation hill paddy, dry land rice and direct sewn upland are term that are describe Upland rice which is grown entirely as rain fed, well drained-non paddled and non-irrigated crops (grist 1975) observed that the land rice varieties grown in the tropic are characterized with rapid emergence from the sort following direct sowing, vigorous seedling growth enabling the crop to complete with weeds, low to medium lettering, insensitivity or weak sensitivity to photoperiod and maturation period ranging from 100 to 125 days.

Mackensize et al (1980) as cited by Ortuoste (1993) rice characteristics are controlled by single mutagens or induced imitation an affected tool for improving specific of existing cultivars particularly, plant height, maturity and certain grain character.

Moorman, as cited by a Datta (1975) noted a positive correlation of ground water and growth of upland rice. He observed that the surface soil with medium to sandy texture overlying and subsoil of their texture are often considered best of upland rice. In the same manner, *Abifarin et al*, as cited by *Clarete (1978)* reported that in West Africa-upland rice most successful on soil with higher water retention capacity.

Reuben and Katuli (1978) as cited by Ortuoste (1993) evaluated 12 upland rice lines from various research centers. Each line was direct sown at 20 x 20 cm spacing in the field under rain fed condition during the 1987 cropping season in randomized complete block design with three replications. The overall yield which range from 1.8 t/ha. to 0.3 t/ha. yielded local check Supa. The low yield was attributed to drought, particularly during the productive stage between booting and grain filling.

MATERIALS AND METHODS

The materials used in this study were as follows: eighteen (18) upland rice seeds, herbicides, pesticides, knapsack sprayer, fertilizer, tiebox, meter stick, record book, and tape measure.

This study was carried out in a randomized complete block design with the 18 upland rice cultivars as treatments replicated three times. The procedure used in this study were the following.

1. Collection
2. Evaluation
3. Purification
4. Seed multiplication and production
5. Seed distribution

RESULTS AND DISCUSSION

A. Plant Height (cm)

Figure 1 showed that the different rice cultivars exhibited significant difference in plant height (Fig 1. Among the upland rice cultivars tested, Dinarado 3 was found out to be the tallest (150.00 cm). Lagani and Dinorado2 cultivars obtained a plant height with a means of 148.00 and 136.00 cm. The NSIC-9 and Dinorado 1 obtained the third and second shortest upland rice cultivars tested. UPL Ri-7 cultivar was significantly the shortest among the cultivars used (85.00 cm). These differences in height could be attributed to the varietal characteristics of the crops planted.

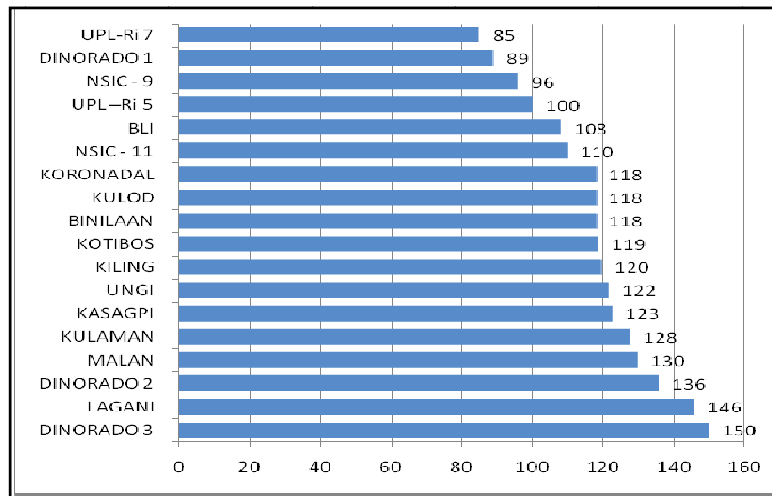

Fig.1: Plant height of Upland rice Cultivars in Sultan Kudarat Province

B. Productive Tillers/hill

The number of productive tillers Fig 2) mostly of all cultivars tested range from 10-12 productive tillers per hill. Only UPL Ri-5 got the lowest productive tillers produced 9.0/hill.

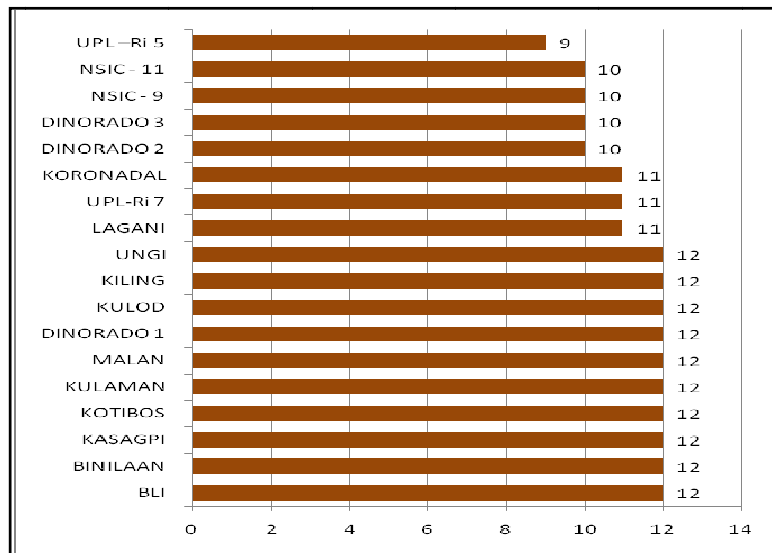

Fig.2: Productive Tillers of Upland rice Cultivars in Sultan Kudarat Province

C. Panicle Length (cm)

The longest length among the cultivars tested was observed in cultivars Kiling with a mean of 32.00 cm, followed by Binilaan and Kasagpi obtained similar length with a mean of 31.00 cm. While the NSIC-11 got the shortest length with a mean of 20.00 cm.

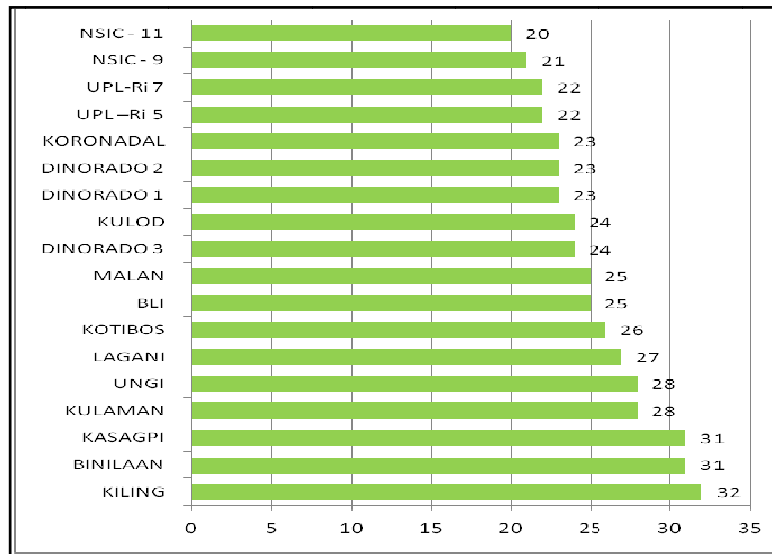

Fig.3: Panicle Length of Upland rice Cultivars in Sultan Kudarat Province

D. Filled Grains/Panicle

The Bli cultivars was found out an obtained the highest number of filled grains per panicle with a mean of 98, followed by Kotibos and Kasagpi with a mean of 97 and 96 filled grains per panicle respectively. While the lowest number of filled grains per panicle was observed in UPL Ri-5 with a mean of 83.

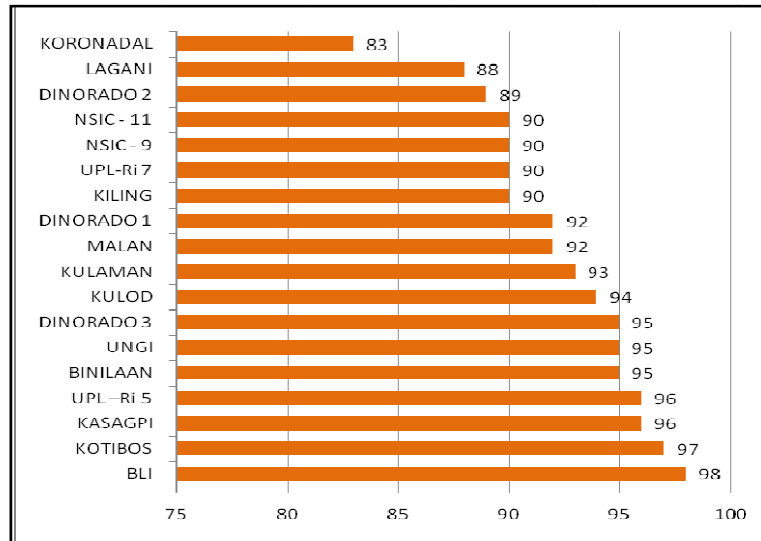

Fig.4:Filled Grains/Panicle of Upland rice Cultivars in Sultan Kudarat Province

E. Number of Days to Maturity (DAS)

The different upland rice cultivars exhibited highly significant differences on the number of days to maturity from sowing (Figure 5). The Kulaman, Dinorado 3, Binilaan, Kasagpi, Kulod and Kiling cultivars were found to be late to mature with the means range from 122- 126 days. Bli, Kotibos, Lagani, Malan, Dinorado 2, NSIC-9,

UPL Ri-5, UPL Ri-5, Koronadal, and Ungi belong to early maturing range from 109-119 days. The Dinorado 1 and NSIC 11 were found to be the very early maturing cultivars among the entries tested with a means of 96 and 105 days.

The result implies that these differences could be attributed to the agronomic characteristics and to the climate adaptability of different upland rice cultivars to the local condition and also to the fertility of the soil.

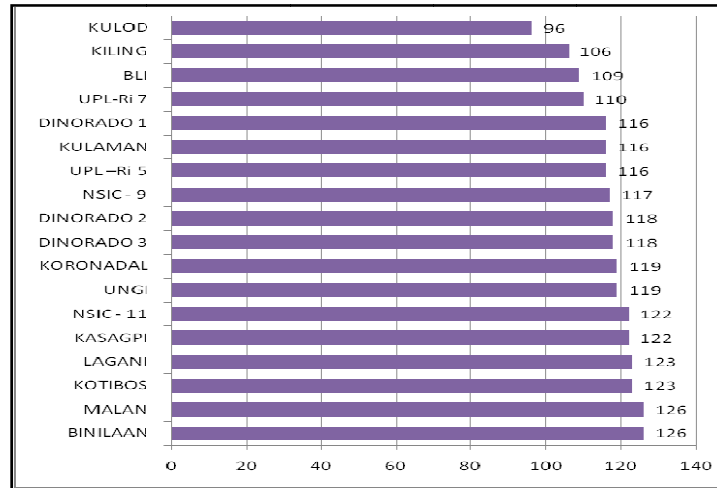

Fig.5: Maturity (DAS) of Upland rice Cultivars in Sultan Kudarat Province

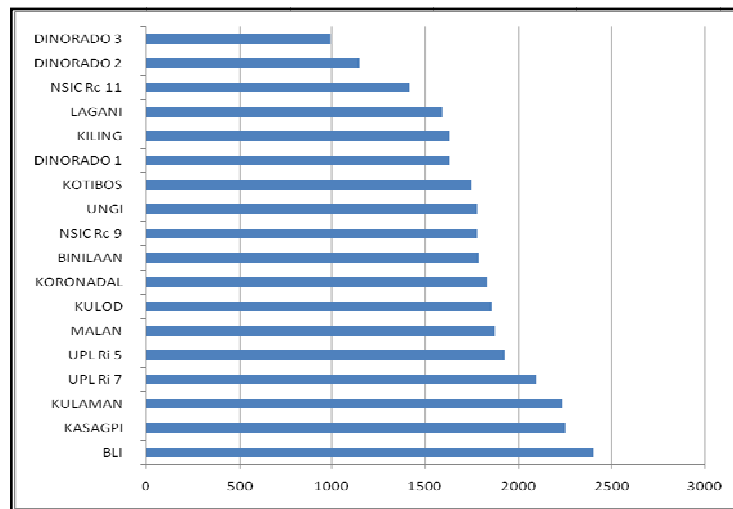

Fig.6: Grain yield (kg/ha) of upland rice cultivars/entries for wet season across locations in Sultan Kudarat Province

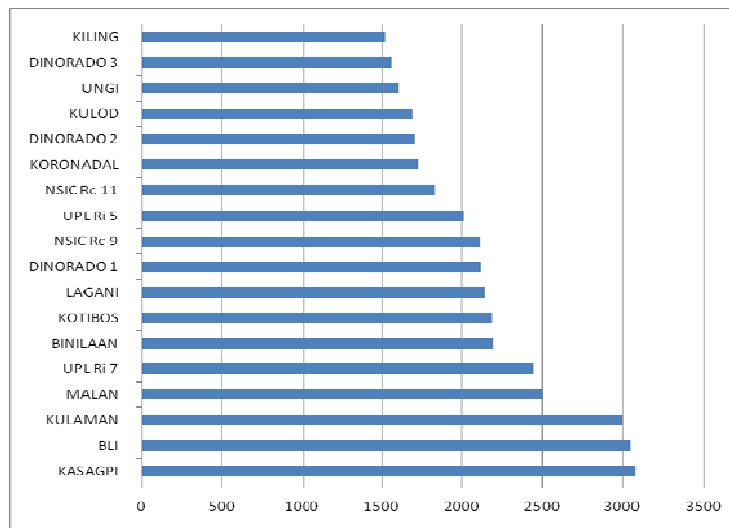

Fig.7: Grain yield (kg/ha) of upland rice cultivars/entries for dry seasons across locations in Sultan Kudarat Province

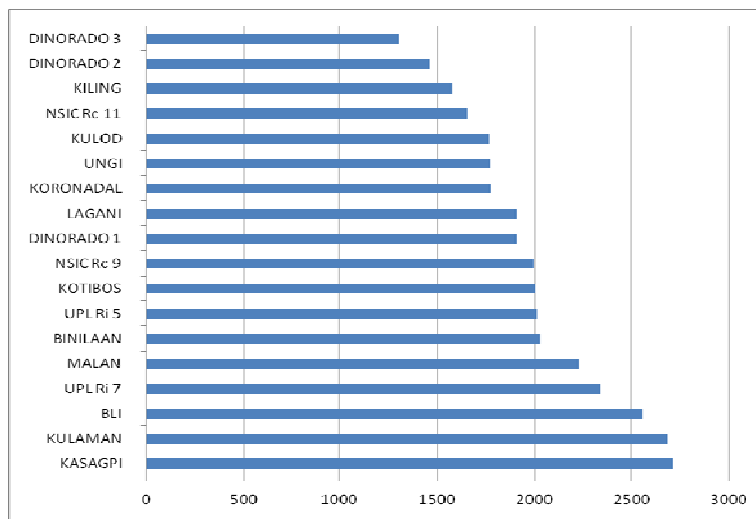

Fig.8: Average Grain yield (kg/ha) of upland rice cultivars/entries for dry(3) & wet(3) seasons across locations in Sultan Kudarat Province

F. Pest and Disease Reaction

The pest and disease reaction of different upland rice cultivars it was found out that during wet season stem borer and leaf folder were observed in some cultivars (Intermediate). While in the dry season rice blast and leaf folder were damage in some cultivars (Intermediate). Only the NSIC-11 varieties got severe damage in rice blast (susceptible) during dry season.

Table.1: Pest and disease reaction of upland rice cultivars/entries planted during wet and dry season, CY 2007-2011`

Entries	Wet season*				Dry season*			
	Stem borer	Leaf folder	Rice blast	Leaf spot	Stem borer	Leaf folder	Rice blast	Leaf spot
1. Bli	Mr	I	R	R	R	I	I	R
2. Binilaan	I	I	R	R	R	I	I	R
3. Kasagpi	Mr	I	R	R	R	I	R	R
4. Kotibos	I	Mr	R	R	R	I	R	Mr
5. Kulaman	Mr	I	R	R	I	I	R	I
6 lagani	I	I	R	R	I	I	R	Mr
7. Malan	I	I	R	R	R	I	I	R
8. Dinorado 1	I	Mr	R	R	R	R	I	I
9. Dinorado 2	I	I	R	R	R	R	I	I

Entries	Wet season*				Dry season*			
	Stem borer	Leaf folder	Rice blast	Leaf spot	Stem borer	Leaf folder	Rice blast	Leaf spot
10.dinorado 3	I	I	R	Mr	I	I	R	R
11. Nsic rc 9	I	I	Mr	Mr	I	R	R	I
12. Nsic rc11	I	I	Mr	Mr	Mr	R	S	R
13. Upl ri 5	I	I	R	R	I	I	I	R
14. Upl ri 7	I	I	R	R	I	R	R	I
15. Kulod	Mr	I	R	R	R	Mr	Mr	R
16.koronadal	Mr	Mr	R	R	R	R	Mr	I
17. Kiling	Mr	Mr	R	R	R	R	Mr	R
18. Ungi	Mr	Mr	R	I	R	R	Mr	R

*R – Resistant;

MR – Moderately Resistant;

I - Intermediate

G. Grain Yield (kg/ha)

The different upland rice cultivars exhibited differences on grain yield as shown in table 2. It was found out that the top yielder among the 18 entries were Kasagpi, Kulaman, Bli UPL Ri 7 Malan and Binilaan with a means of 2712, 2679,2555,2333,2227 and 2022 kg/ha respectively. The increase in yield was principally attributed to the number of grains per panicle, number of productive tillers, varietal yielding capabilities and also to the growth performance of every cultivar tested.

Table.2: Grain yield (kg/ha) of upland rice cultivars/entries for 6 cropping seasons across locations in Sultan Kudarat Province

Entries	Planting schedule (month/year)						Average (kg/ha)
	May to oct, 2008	Nov to april, 2009	Jun to oct 2009	Dec to apr 2010	Jun to oct 2010	June-nov.2011	
1. Bli	2660	4008	3360	2750	1180	2394	2555
2. Binilaan	1530	3110	2690	1675	1135	1808	2028
3. Kasagpi	2180	4120	3550	2690	1020	2417	2712
4. Kotibos	1630	2840	2280	1930	1330	1796	2002
5. Kulaman	2840	4060	2940	2640	915	2307	2679
6. Lagani	1830	2700	2175	2050	780	1685	1907
7. Malan	2030	3360	2360	2160	1225	1982	2227
8. Dinorado 1	1830	2570	2290	2080	780	1705	1910
9. Dinorado 2	945	2790	1840	1055	660	1276	1458
10. Dinorado 3	760	2380	1680	1160	535	1147	1303
11. Nsic rc 9	2030	2350	2450	2285	860	1709	1995
12. Nsic rc 11	1250	2660	2240	1375	755	1466	1656
13. Upl ri 5	2680	2230	2170	2050	930	1758	2012
14. upl ri 7	2680	2950	2580	2430	1025	1955	2333
15. Kulod	2550	2260	1930	1875	1090	945	1770
16. Koronadal	2155	2390	2360	1920	975	877	1779
17. Kiling	1780	2025	1990	1635	1120	900	1575
18. Ungi	1930	2175	2150	1730-	1255	915	1775

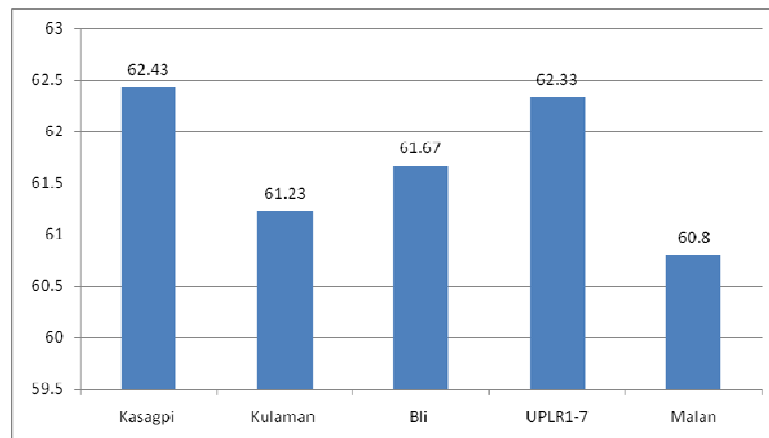

Fig.9: Milling Recovery (kg) of top yielding upland rice cultivars in Sultan Kudarat Province

Figure 9 showed that the highest milling recovery was observed in cultivars Kasagpi with a mean of 62.43 Kg followed by UPLR1-7 (check) with a mean of 62.33 Kg. while the Bli, Kulaman and Malan got a mean of 61.67, 61.23 and 60.80 kgs respectively.

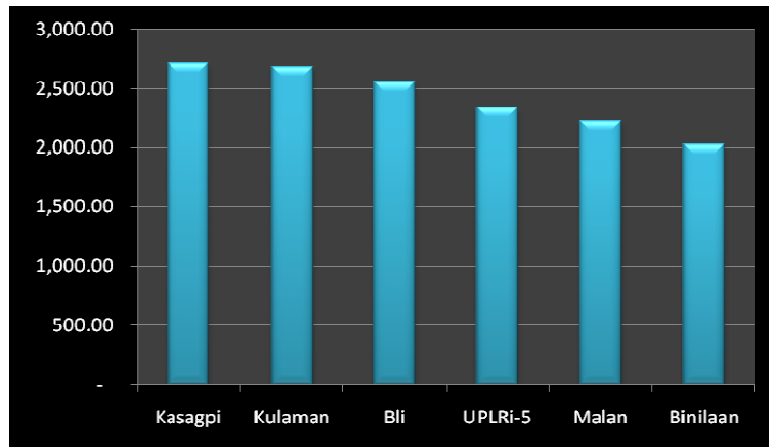

Fig. 10: Average grain yield (kg/ha) of the top six high yielding upland cultivars for 6 cropping seasons across locations in Sultan Kudarat

SUMMARY AND CONCLUSION

1. Indigenous rice cultivars were observed to be taller than check varieties.
2. Productive tillers ranged from 9-12 tillers/hill for wet season and 9-12 tillers per hill during dry season.
3. Majority of indigenous upland rice cultivars obtained longer panicle length compared to check varieties.
4. Bli and Kasagpi cultivars exhibited the most number of filled grains with a mean of 98-96 filled grains per panicle. The lowest were observed from UPL Ri -5 (check) with a mean of 83 filled grains per panicle.
5. Most of the indigeneous cultivars were found to be late maturing (120-128 DAS) while the check are early maturing (95- 116 DAS).
6. In terms of yielding ability, KASAGPI, Kulaman and Bli gave the highest grain yield with a mean of 2712, 2679 and 2555 kg/ha .
7. Field infestation of stem borers and leaf folders was observed during wet season while rice blast infestation was dominant in the area during dry season.

ACKNOWLEDGEMENT

The authors wish to express their profound gratitude and appreciation to the following persons and institutions;

Sultan Kudarat State University - Research Development and Extension for providing necessary financial support of the research study. Special mention to our ever supportive President, Dr. Teresita L. Cambel.

Dr. Rolando F. Hechanova, Vice President for Research Development and Extension, and Dr Ruby S. Hechanova, Director for Research and Development for their endorsement, recommendation and favorable support for the conduct of the study.

RD&E and Tissue Culture Laboratory staff for their assistance making the study successful.

PRAISES and GLORY to our ALMIGHTY GOD for His guidance and blessings all throughout the whole duration of the study.

REFERENCES

Lumbao and Tabili CDA. CEMIARC Adaptability Trial of Different Upland Rice Varieties. PhilRice Annual Report. 67 pp.

Ortuoste, R. 2010. Variety Trial of Upland Rice Cultivars in Sultan Kudarat Province. Terminal Report, 45 pp.

Siesta, et, a.l On Farm Adaptation trial of Promising Upland Rice Varieties and Selection under acid Upland Condition.

Philippine Journal OF Crop Science, 2006.

IMPROVEMENT OF WHEAT (*Triticum aestivum* L.) CROP TOLERANT IN LOWLAND THROUGH MUTATION INDUCTION

Budyastuti Pringgohandoko

Department of Agrotechnology, Faculty of Agriculture,

Universitas Pembangunan Nasional "Veteran" Yogyakarta, Indonesia

Email: bpringgohandoko@yahoo.com

ABSTRACT

In Indonesia, wheat has become a main food after rice into two so that the needs of wheat always increase, reaching 7.4 million tons in 2010-2011 and rose again to 7.8 million tons in 2011-2012. In Indonesia there is not enough land in the highlands for wheat planting in economies of scale. Therefore it is necessary to find an alternative to utilizing the available land in the area that is economically dry land in the lowlands (250-400 m from the sea level). The research objective is to increase the genetic diversity of wheat crop in Indonesia through mutation technique using gamma rays from Cobalt-60, which can be utilized in assessing the high quantity and quality in some wheat mutants, which can be cultivated in the lowlands. The experimental design used was Randomized Complete Block Design (RCBD) with 2 factors. The first factor was an irradiation dose which consists of three levels, namely: 0 Gy, 200 Gy and 300 Gy. The second factor was 4 wheat mutants M2 generation, such as: WL-2265, SA-75, DWR-195 and PN-81, so there were 12 combinations of treatment (Factor I x Factor II = 3 x 4 = 12). Each combination treatment was repeated 3 times (blocks). From the results of this experiment concluded that Gamma ray irradiation with Cobalt - 60 can increase the genetic diversity of wheat plants. Gamma ray irradiation with Cobalt-60 dose of 300 Gy can produce wheat mutants from varieties WL-2265, SA-75, DWR-195 and PN-81 that can grow in the lowlands with higher seed weight/clump, the percentage of seed total protein and seed wet gluten than the non mutant plants.

Key words: *wheat, mutation, mutant*

INTRODUCTION

Wheat (*Triticum aestivum* L.) is an important food crop in the world, both in terms of its contribution as a source of calories as well as protein source. Program introduction of wheat from subtropical to tropical countries has actually been done since 40 years ago by CIMMYT to South Asia and South-East Asia covering nearly 33 million hectares of land area in India, Pakistan, Bangladesh, Burma, Thailand, Philippines, and Indonesia (Haryono, 2001).

In Indonesia, wheat has become a main food after rice into two so that the needs of wheat always increase from year to year. It can be seen from the high consumption in Indonesia is the biggest wheat flour is in the form of noodles. During the years 1990-

1999, the rate of growth in the number of people who consume the noodles in the city was 56.4 % and 67.0 % in villages (Anonymous, 2005). To meet the needs of wheat flour in Indonesia, the government has issued a considerable foreign exchange and each year continues to increase. As from January to December 2007, global wheat price hikes as high as 90 percent. While the price of wheat flour rise 30-40 percent (Wahyuni, 2007). Wheat imports continued to increase, reaching 7.4 million tons in 2010-2011 and rose again to 7.8 million tons in 2011-2012. Dependence on wheat imports from the U.S., the drought that occurred in the United States caused the wheat prices shocks potentially threaten Indonesian food again (Anonymous, 2012). How Indonesia responds to potential price volatility and supply in the country due to drought in the United States, since wheat has become an important component in the food consumption of Indonesian society. If Indonesia can not cope with the above, it will have a serious impact on inflation, and nutrition Indonesian society. Tackle more fundamental issues, which makes Indonesia is always in a position vulnerable to any fluctuation in world food should be done (Anonymous, 2012).

Based on the considerations above, the rate of grain demand is difficult to follow because of the limited supply of foreign exchange to reduce wheat imports in the future be an alternative that must be taken. If this situation occurs then you need to consider is the impact on national food security. To avoid vulnerability due to restrictions on imports of wheat it should be considered to be able to produce wheat locally (Yusuf et al., 2001). The Indonesian government should look at it as an opportunity more seriously to be able to produce its own wheat and more serious about building self-sufficiency (Anonymous, 2012)

In Indonesia there is not enough land in the highlands for wheat planting in economies of scale. Therefore it is necessary to find an alternative to utilizing the available land in the area that is economically dry land in the lowlands (250-400 m from sea level). On such lands major barrier to the growth of wheat is abiotic environmental stresses. At this suboptimum lands, adaptation to abiotic stresses the determining factor in the success of a variety of wheat to be able to generate power according to the potential outcome (Sujiprihati et al., 2001).

Seeing the reality of the importance of wheat to the people of Indonesia and the constraints that exist, it is necessary to begin extracting the potential of tropical plants such as wheat through plant breeding research program. Because wheat is not a native to Indonesia, the existing wheat varieties are generally derived from the introduction, so that the genetic diversity of wheat in Indonesia is still very limited. Plant breeding requires a high genetic diversity of plants that can be selected according to the desired breeding objectives. Program for the success of planting wheat in tropical Indonesia with good quality results and one of them is through mutation. The use of low-dose irradiation is quite capable of causing genetic effects bigger and better results than choosing a higher dose of irradiation but a lot of physical damage (Inawati, 2004).

Until now it has never been reported study of mutations in wheat plant breeding for tolerance in lowland temperature is generally high. Given the importance of information about the wheat crop strains that can be cultivated in the lowlands with high temperatures in an effort to get mutants that is tolerant to environmental stresses in Indonesia, this research needs to be done.

The research objective is to increase the genetic diversity of wheat crop in Indonesia through mutation technique using gamma rays from Cobalt-60, providing wheat crop genetic diversity to allow further selection is done to get a new genetic resource that can be utilized in hybridization program, assessing the quantity and quality of wheat in some wheat mutants, which can be cultivated in the lowlands with a high quantity and quality results.

To meet the needs of wheat flour in Indonesia, the government has issued a considerable foreign exchange and always increasing. In 1999 the wheat needs to reach 3 million tons, while in 2000 has reached 3.9 million tons (Anonymous, 2000). Currently Indonesian wheat imports of 4.5 million tons per year (Purmono, 2004). Approximately 80 % of wheat imports obtained from Australia, while the rest of America and Canada (Subandi et al., 2001). As from January to December 2007, global wheat price hikes are expected to reach 90 percent. While the price of wheat flour will rise 30-40 percent (Wahyu, 2007). Based on the considerations above, the rate of grain demand is difficult to follow because of the limited supply of foreign exchange to reduce wheat imports in the future be an alternative that must be taken. If this situation occurs then you need to consider is the impact on national food security. To avoid vulnerability due to restrictions on imports of wheat it should be considered to be able to produce wheat locally (Yusuf et al., 2001).

Jusuf et al. (1993), argues that the condition of uninterrupted growth rates of pests and diseases of wheat in general linear according to altitude. It means that the higher the elevation the better growth and higher plant biomass, and production increased. Wheat production target of at least 2 tones / ha for plain medium (500-700 m from sea level) with the age range 90-120 days and 3 tons / ha for upland (> 700 m from sea level) with the age range 100-150 days, so it is possible to enter this plant into crop farming in general. With such a range of ages expected wheat can be planted after the dry season rice crop. Another advantage is the increased diversity of species cultivated farmers so that the likelihood of genetic vulnerability can be avoided in the field (Yusuf et al., 2001).

In Indonesia there is not enough land in the highlands for wheat planting in economies of scale. Therefore it is necessary to find an alternative to utilizing the available land in the area that is economically dry land in the lowlands (250-400 m from sea level). On such lands major barrier to the growth of wheat is abiotic environmental stresses such as high temperatures and drought. At this suboptimum lands, adaptation to abiotic stresses the determining factor in the success of a variety of wheat to be able to generate power according to the potential outcome (Sujiprihati et al., 2001).

Seeing the reality of the importance of wheat to the people of Indonesia and the constraints that exist, it is necessary to begin extracting the potential of tropical wheat plants through plant breeding research program. Because wheat is not a native to Indonesia, the existing wheat varieties are generally derived from the introduction, so that the genetic diversity of wheat in Indonesia is still very limited. Plant breeding requires a high genetic diversity of plants that can be selected according to the desired breeding objectives. Program for the success of planting wheat in tropical Indonesia with good quality results and one of them is through mutation, as has also been done in some countries that is not a country of origin wheat crop. Mutations will be reflected in

the genetic variation of plants, which then through the selection process and will allow further testing to obtain a variety of crops (Soeranto, 2001).

OBJECTIVE

Research purposes by mutation using gamma rays from Cobalt - 60 on wheat plants are:

1. Increase the genetic diversity of wheat crop in Indonesia through mutation technique using gamma rays from Cobalt - 60.
2. Providing wheat crop genetic diversity to allow further selection is done to get a new genetic resource that can be utilized in hybridization program.
3. Find mutants of wheat that can be grown in the lowlands with a high yield quantity and quality.

MATERIALS AND METHODS

A. Plant culture

Field research was conducted at the Experimental field of Gadjah Mada University in Banguntapan District, Yogyakarta at an altitude of 150 m above sea level. Preparation of planting medium by mixing soil and manure regosol a ratio of 2:1, which was subsequently mixed media put in a poly bag with a diameter of 25 cm to \pm 5 cm from the surface of the poly bag. After that, planting seeds in a planting medium in a poly bag \pm 1 cm deep, a seed per poly bag planted wheat. Next, watering is done to maintain moisture at field capacity media, but it kept to a wheat crop not to dryness. Fertilization was applied, such as: Urea, SP-36, and K₂O₅ with 1-2-1 ratio g/poly bag. Fertilization is done 2 times, the third section at planting and the second residual fertilizer when the plants are given 40 days. Weeding is done three times, the first at four weeks after planting, second at eight weeks after planting, and the third line with the growth of weeds. Pest and disease control are chemically by using Thiophatane methyl (Topsin M70 WP) 0.77 kg / ha or Propiconazole (Tilt 250 EC) of 0.40 l/ha.

B. Treatment

The experimental design used was Randomized Complete (RCBD) with 2 factors. Factor I was the dose of gamma ray irradiation, namely:

D0: Without irradiation

D1: Irradiation 200 Gy

D2: Irradiation 300 Gy

Factor II: the wheat mutant plants M₂ generation, such as: V1 (WL-2265), V2 (SA-75), V3 (DWR-195), and V4 (PN-81)

Factor I x Factor II there are 3 levels there are 4 levels = 3 x 4 = 12 combinations of treatments were repeated 3 times (blocks) and each treatment combination consisting of 29 plants.

C. Measurements

1. The average weight of seeds/clump, by weighing all seeds produced from each sample's plants in each treatment combination.
2. Percentage of total seed protein, the analysis is done by using a micro-Kjeldahl method.
3. The content of gluten, analysis of amino acid composition and content of gluten was measured by Size - Exclusion High-Pressure Liquid Chromatography (SE-HPLC).

D. Statistical analysis

The data were analyzed using analysis of variance at the 5% significance level, and followed by Duncan's multiple range tests at the 5% significance level if there is a significant difference between the combination treatments.

If the observation samples is not homogeneous, then the transformation of the experimental data so that the data will be processed in accordance with the procedure analysis of variance meet all the assumptions underlying the validity of the use of a analysis of variance, so the results of this analysis can reflect events that actually happened in an experiment. In other words, in order to recommendations made from the conclusion of the analysis of variance be credible and can be used as guidelines for the users (Gomez and Gomez, 1983).

RESULT AND DISCUSSION

A. The average seed weight/clump

Results of analysis of variance showed that there is an interaction between wheat varieties and irradiation dose in influencing seed weight/clump. The average of seed weight/clump is presented in Table 1.

Table 1. The average of seed weight/clump

Wheat Varieties	Irradiation Dose (Gy)			Average
	D0 (0 Gy)	D1 (200 Gy)	D2 (300 Gy)	
V1 (WL-2265)	6,76 b P	3,14 c P	22,78 a P	10,89
V2 (SA-75)	4,34 b Q	3,41 c P	5,25 a S	4,33
V3 (DWR-195)	4,38 b Q	3,79 c P	19,73 a Q	9,30
V4 (PN-81)	0,96 b R	2,26 a Q	1,36 b R	1,27
Average	4,11	3,15	12,28	6,45 (+)

Description: Mean followed by the same letter in the column (capital letters) and rows (lower case) showed no significant difference based on Duncan 's Multiple Range Test at the 5% significance level. Sign (+) indicates no interaction.

At V1, V2 and V3, the D2 treatment has the heaviest seed weight/clump compared to D0 and D1. At V4, the D0 and D2 treatments markedly more severe than the D1 treatment, but between D0 and D2 treatments there are no significant difference. In the D0 treatment, seed weight/clump of V1 is significantly higher compared to V2, V3 and V4, but between V2 and V3 there is no significant difference. In the D1 treatment, grain weight on V1, V2 and V3 are heavier than V4, however between three of them there is no significant difference. At the D2 treatment, seed weight in V1 plants significant higher compared to V2, V3 and V4.

On the parameter grain weight/clump, on plants that are not irradiated showed that the WL-2265 varieties most heavily weighted real seeds, while the PN-81 varieties lightest real. In the irradiation treatment at a dose of 200 Gy, WL-2265 varieties of real lighter while varieties manifest PN-81 is heavier although still lighter than the real WL-2265 varieties. On irradiation at a dose of 300 Gy, WL varieties become more apparent than on the weight not irradiated. This suggests that in addition to possible changes in grain weight/clump due to mutations caused by the high number of real seeds and weighs 100 grains which include high grain weight/clump resulted in a real highest, while the PN-81 varieties despite the high weight of 100 seeds but because of the amount of very few seeds the seed weight per clump into real lighter.

B. Percentage of seed total protein

Results of analysis of variance showed that there is an interaction between wheat varieties and irradiation dose affects the percentage of total protein in wheat seed. Percentage of seed total protein is presented in Table 2.

Table 2. Percentage of seed total protein (%)

Wheat varieties	Irradiation Dose (Gy)			Average
	D0 (0 Gy)	D1 (200 Gy)	D2 (300 Gy)	
V1 (WL-2265)	10,49 b P	13,01 a P	12,47 a P	11,99
V2 (SA-75)	10,44 b P	11,78 a Q	12,46 a P	11,56
V3 (DWR-195)	11,18 b P	12,87 a PQ	13,17 a P	12,41
V4 (PN-81)	10,73 a P	11,84 a PQ	11,36 a Q	11,31
Average	10,71	12,38	12,37	11,82 (+)

Description : Mean followed by the same letter in the column (capital letters) and rows (lower case) showed no significant difference based on Duncan 's Multiple Range Test at the 5% significance level. Sign (+) indicates no interaction.

At V1, V2 and V3, D1 and D2 treatments markedly greater than the percentage of total seed protein D0 treatment, but the treatment of D1 and D2 there is no significant difference. At V4, treatment D0, D1 and D2 showed no significant differences. In the D0 treatment, the percentage of total protein in wheat seed V3 no significant difference between V1, V2, V3 and V4. In the D1 treatment, the percentage content of gluten real V1 is greater than V2, but the V1 to V3 and V4 no real difference. In the D2 treatment,

the percentage of total plant protein V4 significant low when compared to the V1, V2 and V3, but between V1, V2 and V3 there is no significant difference.

C. Percentage of wet gluten content of wheat seed

Results of analysis of variance showed that there is an interaction between wheat varieties and irradiation dose in influencing the percentage of wet gluten content of wheat seed. The mean percentage of wet gluten content of wheat seed are presented in Table 3. On V1 and V3, the D1 treatment caused the percentage of gluten significantly difference, it is higher than in D0 and D2 treatments. At V2 and V4, D1 and D2 treatments showed no significant differences in wet gluten content, but both are higher than the percentage of gluten in D0 treatment.

Table 3. Percentage of wet gluten content of wheat seed (%)

Wheat varieties	Irradiation Dose (Gy)						Average
	D0 (0 Gy)		D1 (200 GY)		D2 (300 Gy)		
V1 (WL-2265)	33,04	c	59,79	a	48,03	b	48,03
	Q		Q		R		
V2 (SA-75)	33,03	b	47,96	a	49,72	a	49,72
	Q		R		R		
V3 (DWR-195)	54,11	c	65,60	a	58,70	b	58,70
	P		P		P		
V4 (PN-81)	35,37	b	51,45	a	54,02	a	54,02
	Q		R		Q		
Average	38,89		56,20		52,62		49,24 (+)

Description : Mean followed by the same letter in the column (capital letters) and rows (lower case) showed no significant difference based on Duncan 's Multiple Range Test at the 5% significance level. Sign (+) indicates no interaction.

In the D0 treatment, the percentage of gluten content in wheat seeds significantly different between V3 compared with V1, V2 and V4, but no between V1, V2 and V4. In the D1 treatment, the percentage of gluten in V3 also the most obvious comparison to V1, V2 and V4, but between V2 and V4 are not significant difference. In the D2 treatment, the percentage of gluten in V3 seeds keep it significant different when it was compared to V1, V2 and V4, but between V1 and V2 there is no significant difference.

DISCUSSION

From the results of the analysis show that the influence of wheat varieties and gamma irradiation doses showed that there is interaction at all parameters, i.e.: seed weight/clump, percentage of total protein and percentage of wet gluten wheat seeds.

On the parameter grain percentage of total protein showed no significant differences between wheat varieties that do not get treatment irradiation. In plants that were irradiated with a dose of 200 Gy and 300 Gy, varieties WL-2265, SA-75 and DWR-195 experienced a noticeable increase in the percentage of total seed protein, but the PN-81 varieties are not experiencing real changes. This indicates that irradiation changes the structure of the gene plays a role in controlling the formation of proteins. Although the

percentage of total protein was also greatly influenced by the environment, but in this study the environments effect on the percentage of total protein as environmental stresses do not occur.

On the parameter grain percentage of total protein showed no significant differences between wheat varieties that do not get treatment irradiation. In plants that were irradiated with a dose of 200 Gy and 300 Gy, varieties WL-2265, SA-75 and DWR-195 experienced a noticeable increase in the percentage of total seed protein, but the PN-81 varieties are not experiencing real changes. This indicates that irradiation changes the structure of the gene plays a role in controlling the formation of proteins. Although the percentage of total protein was also greatly influenced by the environment, but in this study environments this effect on the percentage of total protein as environmental stresses do not occur.

In the parameter of the percentage wet wheat seed gluten content, mutant DWR-195 has the highest compared with varieties WL-2265, SA-75 and PN-81. In plants that are subjected to irradiation at a dose of 200 Gy and 300 Gy, all experienced marked improvement. This is in addition to the effect of mutations that occur as well as an increase in the percentage of total protein that occurs primarily in protein gliadin and glutenin. Both of these proteins are able to form a combination of a protein complex called gluten. Gluten most abundant in wheat germ, can reach 80 % of the total protein. Because gluten is very influential in the dough to be springy, elastic, plastic, and dull the increase of irradiation treatment on the gluten of wheat varieties to obtain mutant wheat varieties is indispensable in improving the quality.

CONCLUSION

1. Gamma ray irradiation with Cobalt-60 can increase the genetic diversity of wheat plants in Indonesia with the parent WL-2265, SA-75, DWR-195 and PN-81, so they can be used as a source of new genetic hybridization program.
2. a. Gamma ray irradiation with Cobalt-60 dose 200 Gy in varieties PN-81 produced wheat mutants, that can tolerant in the lowlands with higher seed weight/clump and the percentage of wet seed gluten compared to non mutants.
 - b. Gamma ray irradiation with Cobalt-60 dose of 200 Gy in varieties WL-2265, SA-75 and DWR-195 produced wheat mutants, that can tolerant in the lowlands with higher percentage of seed total protein and the percentage of wet seed gluten than the non mutants.
 - c. Gamma ray irradiation with Cobalt-60 dose of 300 Gy in varieties WL-2265, SA-75 and DWR-195 produced wheat mutants, which were tolerant in the lowlands with higher seed weight/clump, the percentage of seed total protein and the percentage of wet seed gluten compared to non mutants.

REFERENCES

Anonymous. 2005. Agricultural Research and Development News: Food Consumption Trend Wheat Products in Indonesia. At: <http://pustaka.bogor.net/publ/warta/w2556.html> accessed on 10 November 2005.

- Anonymous. 2012. Indonesia to get food crisis easily. Kompas.
- Gomez, K.A. and A.A. Gomez. 1983. Statistical Procedures for Agricultural Research. 2nd edition. An International Rice Research Institute Book. A Wiley-Interscience Publication. John Wiley & Sons. New York. Chichester. Brisbane. Toronto. Singapore. P. 294-315.
- Haryono, S.K., 2001. Wheat Development in Tropical Environmental Conditions. Prospects and Constraints. Hall Seed Control and Certification of Food Crops and Horticulture II Central Java.
- Inawati, N. 2004. Identification of agronomic wheat (*Triticum aestivum* L.) mutant features (M2) through mutation induction whit Gamma Co-60. Skripsi. Agricultural Faculty. Universitas Pembangunan Nasional. Yogyakarta.
- Jusuf, M., H. Bahar, A. K., Harmel, D. Jamin, Asmaniar, Dasmal and L. Bahri. 1993. Thai Punjab 81 and 88 Candidates of Wheat Varieties For Tropical Climate Indonesia. Meeting on Technical Team Waiver Crop Varieties, 17 to 18 March.
- Jusuf, M., A.A. Daradjat and M. Dahlan. 2001. Release of Varieties experience Nias and Wheat Development in the Future. Hall Seed Control and Certification of Food Crops and Horticulture II Central Java. Thing. 15-28.
- Purmono, A. 2004. Rated Wheat Development in Indonesia Prospective. Breaking edition 3 September 2004.
- Soeranto, H. 2001. Plant Breeding Research Wheat (*Triticum aestivum* L.) With Mutation Technique. In " Adaptation Test / Discharge Preparation Wheat Varieties in Central Java". Subagyo. Hall Seed Control and Certification of Food Crops and Horticulture II. Central Java. Thing . 29-39.
- Subagyo. 2001. Adaptation Test / Discharge Preparation Wheat Varieties in Central Java. Hall Seed Control and Certification of Food Crops and Horticulture II Central Java. Thing. 1-14.
- Subandi, M. Joseph, Rudiyanto, E. Pudjiharti. 2001. Initial Selection and Seed Production of Wheat (*Triticum aestivum* L.) varieties DWR-162 from India. Research Report Aimed To PT Bogasari Flour Mills. Faculty of Agriculture, University of Slamet Riyadi Surakarta and Discourse Satya Christian University Salatiga.
- Sujiprihati, S., D. Sopandie, S. Sastrosumarjo and Trikoesoemaningtyas. 2001. Wheat research at the Center for the Study of Plant Breeding, Department of Agriculture, Bogor Agricultural University. Hall Seed Control and Certification of Food Crops and Horticulture II Central Java.
- Soeranto, H. 2001. Plant Breeding Research Wheat (*Triticum aestivum* L.) With Mutation Technique. In " Adaptation Test / Discharge Preparation Wheat Varieties in Central Java". Subagyo. Hall Seed Control and Certification of Food Crops and Horticulture II. Central Java. Thing. 29-39.
- Wahyuni, A. I. 2007. Wheat price increases 90% during 2007. Detikfinance.

UTILIZATION OF WASTE PALM OIL AS A SOURCE SOIL ORGANIC MATTER FOR SUPPORT GREEN AGROINDUSTRY

S. Setyo Wardoyo¹⁾

¹⁾Department of Agro-technology (Soil Science) UPN "Veteran" Yogyakarta.

Ring road street, Condongcatur Yogyakarta 55283 Telp/Fax. 274-486737.

Email: setyowdy@gmail.com

ABSTRACT

Indonesian climate conditions that have a high temperature and humidity, to support the rapid proliferation of soil microbes including cellulolytic microbes, so that decomposition of soil organic matter goes very fast. As a result of mineral soils in Indonesia are generally poor organic matter. While the abundance of oil palm waste, not fully utilized as raw material for downstream, and the waste created circumstances that disrupt the environment. As an alternative to resolve palm oil waste is utilized as a source of soil organic matter. Organic matter to improves soil physical, chemical and biological soil and healthy environment. Thus it can help support the creation of good green Agro-industry.

Key words: oil palm waste, soil organic matter, agro-industry

INTRODUCTION

Indonesia has a tropical area especially temperature and high humidity as a result of decomposition of soil organic matter goes very fast, so that the mineral lands in Indonesia generally contain low organic matter. As a result the physical, chemical and biological soil is not good, and easily eroded. More so with the loss of nutrients transported through harvest with no effort to bring it back.

Palm plants have waste, in the form of plant parts that are not past the stage of processing of oil palm empty fruit bunches example. Parts of this plant can be a waste because there is widespread use of waste treatment technologies in the oil palm farmers, lack of expert personnel and skilled workers as well as the lack of investor interest in the business in the processing of agricultural waste.

The expansion of oil palm plantations are also an abundance of agricultural waste has consequences. People have realized that the abundant waste will interfere with the environment or be a disposal problem. At the end of the 20th century, many experts began to researching on waste to be a by-product and the rest though again become useful materials such as organic fertilizer into the soil to be restored again, but not all of the palm oil industry utilizing these technologies. Agricultural waste is not only used for agriculture alone, but can be used for food industry, livestock feed, pharmaceuticals, cosmetics and construction. Many things once unimaginable is now becoming a reality. To the authors limit the waste as a source of soil organic matter, which is derived from plant oil palm.

A. Waste Oil Palm And Results Of Side

Terms of waste, just for a while before there is technology that can process them into useful material. Once available technology modifiers waste into useful products, the waste is turned into byproducts.

Harvested in the form of palm oil fresh fruit bunches (FFB). Separation of the fruit from FFB, will leave waste or slender bunches that in terms of plantation called "empty fruit bunches". The next process in the factory, the fruit will produce crude palm oil products and coir waste (wet / dry pulp) and leave nuts palm. Crude palm oil will result in major palm oil products and liquid wastes left which is called by Sludge. At a later stage the nuts will be separated again from its shell to the kernel. Shell can create byproducts activated carbon, charcoal and norit. While the kernel can produce palm kernel oil and oilcake which will also create a by-product of alcohol, vinegar, sugar and cattle feed (Naibaho, 1990).

In more developed countries, oil palm Agroindustry already utilize these wastes into by-product, in the form of organic fertilizer, cattle feed or as material of paper, pulp, cement board, etc. (Figure 1). Expected future all Indonesian oil palm agro-industry has been utilizing these wastes into by-product or other industrial raw materials.

1. Oil Palm Empty Fruit Bunches

Empty fruit bunches obtained from the separation of fresh fruit bunches (FFB) with fruit. Number of empty fruit bunches estimated 27% of FFB. Palm oil production on land Class II by 24 tonnes FFB / ha / yr. In 2012, the area of oil palm plantations in Indonesia covering an area of 9,074,621 ha (Ministry of Agriculture, 2013). Thus a total waste of empty fruit bunches estimated 58.8 million tons / yr. The empty fruit bunches, previously only stacked near the factory even spread on sidewalks to the garden, thus disturbing environment. On a small scale empty fruit bunches used for fuel and ash to raise the pH of acid soils.

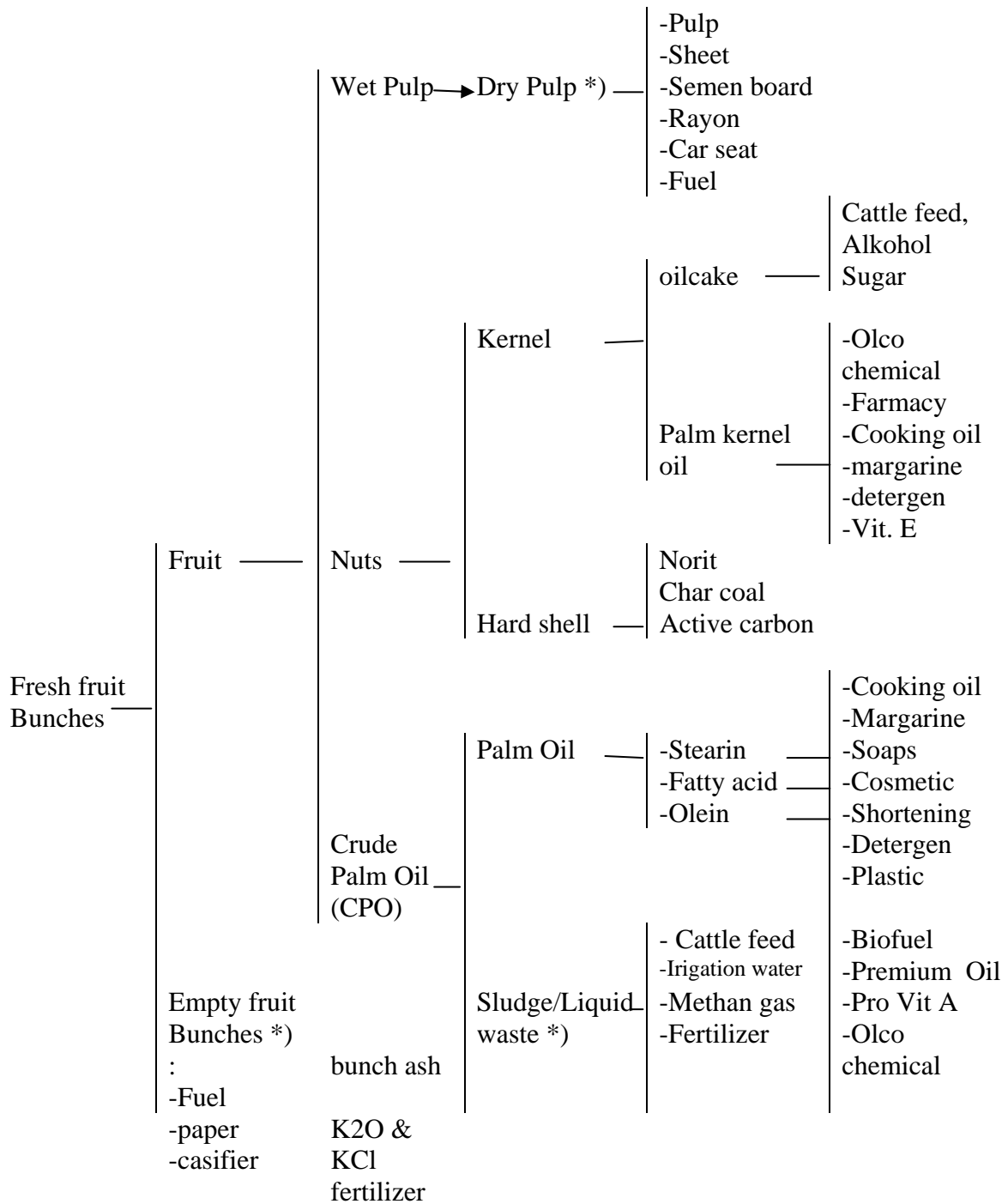

*) potential as soil organic matter

Figure 1. Chart of Palm Oil Products and Possible It Usage (Naibaho, 1990; modified).

In 1982 some researchers began using the ash bunches for soil research, although the numbers are still limited. Panjaitan, Soegijono and Sirait (1983) have examined the effect of empty fruit bunches ash on podzolic, regosol and alluvial soil pH changes. Empty fruit bunches ash analysis results obtained highest K₂O content is 40.79% (Table 1), so it is often used as a fertilizer K is equated with KCl. Another element that is also high after K₂O are MgO, CaO and Cl. The results showed that for podzolic soil pH

change from 5.2 to 6.5 requires empty fruit bunches ash dose 5.2 kg / palm trees, whereas the ground regosol of pH 5.7 to 6.5 requires 2.5 kg ash / trees and alluvial soils of pH 5.3 to 6.5 requires ash 5.8 kg / tree.

Table 1. Results Analysis of oil palm empty fruit bunch ash (Tampubolon, 1982)

No	Kind the element	Average
1.	pH	12.0
2.	K ₂ O	40.79 %
3.	C-organic	0.79 %
4.	N-total	0.10 %
5.	P ₂ O ₅	4.51 %
6.	CaO	5.51 %
7.	MgO	9.77 %
8.	Cl	4.90 %
9.	Na ₂ O	0.14 %
10.	Mn	0.13 %
11.	Fe	0.31 %
12.	Cu	99 ppm
13.	B	295 ppm
14.	Zn	381 ppm

At different times Panjaitan et al (1983) to continue his research on the P available on the same soil type with empty fruit bunches ash dose equivalent to 0.215 kg P₂O₅/tree for podzolic soil, 0.232 kg /tree for alluvial soil and 0.103 kg/tree to the ground regosol . The results showed that the dose increase P available on podzolic soil, but do not raise the P available on alluvial soil and regosol, because the soil is already available P have each medium and high.

Empty fruit bunches mostly composed by long-chain C such as lignin 27.4% (Tun Tedja, 1991), cellulose and other carbohydrates, making it difficult to decompose. With the rapid development of biotechnology, it has been discovered microorganisms capable of producing extracellular enzymes that degraded lignin and cellulose quickly on oil palm empty fruit bunches. In practice empty fruit bunches should be cut first, and composted. At the time composting efforts need to be made as follows:

Adding nutrients N, to lower the C / N ratio to avoid immobilization N.

- a. Adding cellulolytic microorganisms namely fungi *Neurospora sitophila* as cellulase and xylanase enzyme producer. This enzyme is able to hydrolyze empty fruit bunches and palm coir into sugar before having delignification (Tun Tedja, 1991). Thus the decomposition will be faster.
- b. Adding elements of P. Decomposition will be faster when the ratio of C / N / P = 100/10/1
- c. With attention to environmental factors such as pH compost, aeration, moisture and temperature.

2. Coir Palm Oil

Coir obtained from the results separation of the fruit into coir (still containing oil) with nuts; later coir pressed crude palm oil will come out and leave the coir / wet pulp. On a

small scale wet pulp is dried to be used to make car seats, fuel, cement board, rayon, carpet, pulp and paper. This effort has not been widespread all oil palm plantations, so still not solve the problem of oil palm coir waste. Coir is also dominated by lignin is 21.56% (Table 2), then composting into soil organic matter the same with compost empty bunches. To accelerate the degradation, Harrey (1992) have examined the composting coir palm with inoculum giving *Humicola lanuginosa* and *Neurospora sitophila*. *H. lanuginosa* used because they have the privilege to be thermophilic, can degrades lignin compost 45-65 °C, while *N. sitophila* are mesophilic, can degrades lignin at a temperature of 25-35 °C compost (Wardoyo, 1993). The results showed that after the inoculum was grown for 10 days, it can be 50% lower lignin content.

Table 2. Palm Coir composition (Harrey, 1992)

No	Kind the element	Contents (%)
1.	Lignin	21,56
2.	P ₂ O ₅	0,12
3.	K	0,91
4.	Ca	0,19
5.	Mg	0,23
6.	Na	0,81
7.	Mn	0,08

3. Palm oil sludge

Sludge is the residual liquid waste processing palm oil that has been compacted. The amount of sludge is less than 2% of FFB. Pada 1988 the amount of waste palm oil mills in Indonesia about 44,400 tons of BOD per day with 25 g / l (Tobing and Loebis, 1990). The resulting sludge that can be directly used and is non-toxic, then the waste water must be treated by anaerobic fermentation. The treatment will be BOD of 25,000 mg / l to 200 mg / l and COD of 54 850 mg / l to 1,230 mg / l. Similarly, the concentration of elements is generally down, except Boron (Table 3). With such treatment, then the rest of the solidified waste can be used directly as an ingredient stabilizer soil structure.

Table 3. Results of analysis Liquid Waste Palm Oil (Tobing and Loebis, 1990).

No	Type of Nutrients	Concentration before fermentation (mg / l)	Concentration after fermentation (mg / l)
1.	N-total	100	50
2.	P total	50	10
3.	K total	300	100
4.	Ca total	240	200
5.	Mg total	120	30
6.	Mn	0,40	0,01
7.	Fe	3,30	0,80
8.	Cu	0,07	0,03
9.	B	0,01	0,20
10.	Zn	0,70	0,20

Hanafiah and Jusuf (1988) have examined the effect of sludge on the growth and production of corn. The results showed that a dose of 1.8 kg / plant with sludge 12 weeks maturity level, it can increase corn production of 1.1 tonnes / ha.

B. Benefits Of Soil Organic Matter

No doubt that organic matter can improve the physical, chemical and biological soil; either directly or indirectly. Improvement of soil properties reflected in better plant growth and satisfactory results.

1. Physical properties of soil

Organic matter can improve the structure, because it stimulates the formation of soil aggregates through physico-chemical processes. Stable aggregates will increase the ability to binding water and soil nutrients, better aeration, tillage-range is greater, the fulcrum of the reduced penetration and permeability is more stable. Organic matter also reduce soil erosion, because of the infiltration capacity and run-off are small

2. Chemical Properties

The direct benefits of organic matter as a source of N, P, S through mineralization. Mineralization process sometimes produces nutrient elements available in the form of a profitable crop, but sometimes freeing toxic compounds. Indirect benefits that increase the CEC, help provide N through fixation of atmospheric N₂, freeing a fixed P, chelating micro elements, adsorbs pesticide and other organic compounds. Humus formed from organic matter has a positive and negatively charged groups. Positive cluster can hold such phosphate anions, nitrate and sulfate.

3. Biological Properties

Organic matter were as a source of energy and C source for soil microbes. The addition of organic matter will improve the soil mibrobia activity, increased microbial saprophyte that produces antibiotics, phenolic acids and even compounds inhibiting pathogen.

CONCLUSION

The rapid degradation organic matter in the tropics, if attributed with the use of organic matter, then it is imperative for us to manage the land in such a way that the lack organic matter is not the case. I increase the original organic matter in the soil and add from outside the land.

Organic matter does have some weakness such as low nutrient levels, high volume, making it difficult to transport, difficult dose determined with certainty, often contain heavy metals as well as disease carriers, but if we are oriented to save the environment, then the composting the waste that has accumulated around the palm oil mill important. Finally compost from empty fruit bunches waste can be reused by plants as fertilizer, while the environment for the better. Thus the utilization of palm oil waste can support green agro-industry.

REFERENCES

Ministry of Agriculture. 2013. Production, Area and Productivity of Indonesian plantations.

<http://www.deptan.go.id/Indikator/tabel-3-prod-lsareal-prodvtas-bun.pdf> [22-09-2013].

- Hanafiah and S. Jusuf. 1988. Effect of dose and level of maturity of oil palm waste (sludge) as organic fertilizer on the growth and production of maize. *Bul. Pert.* Vol. 7 (3).
- Harrey, 1992. Composting of oil palm ith abut giving inoculum *Humicola lanuginosa* and *Neurospora sitophila*. Thesis S2 IPB. Bogor.
- Naibaho, P. M. , 1990. Prospects for the development of downstream palm oil industry. Proc. Technical meeting of palm oil. Pekanbaru.
- Panjaitan, A., Sugijono and Sirait. 1983a. Effect of oil palm bunch ash on acidity (pH) for podzolic, regosol and alluvial soil. *Bul. BPP Medan.* Vol. 14 (3).
- Panjaitan, A., Sugijono and Sirait. 1983b. Effect of oil palm bunch ash on P available on podzolic soil, regosol and alluvial. *Bul. BPP Medan.* Vol. 14 (3).
- Tampubolon, M. 1982. Possibility of utilization of farm waste. Proc. Workshops PN/PTP I and P4TM. Medan.
- Tobing, P. L. and B. Loebis. , 1990. Reduction and utilization of oil palm waste. Proc. Technical meeting of palm oil. Pekanbaru.
- Tun-Tedja, I. , 1991. Production of extracellular enzymes (cellulase and xylanase) from *Neurospora sitophila*. IPB S3 dissertation. Bogor.
- Wardoyo, S. S. , 1993. The influence of environmental factors on soil organism lives and productivity of the land. Scientific lectures HIMITA Fac. Agriculture UPN "Veteran" Yogyakarta.

IMPROVING SOIL PRODUCTIVITY WITH BIOCHARS

Arnoldus Klau Berek and Nguyen V. Hue

Department of Tropical Plant and Soil Sciences, University of Hawaii at Manoa; St. John Plant Science Lab, Room 102, 3190 Maile Way, Honolulu, Hawaii 96822 USA.

akberek@hawaii.edu

ABSTRACT

Biochar is a stable form of charcoal produced from heating organic materials in a high temperature and low oxygen process. Due to its porous nature, surface functional groups, and other properties, biochar could serve as a beneficial soil amendment. To investigate this potential of biochars, six wood-derived biochars were characterized, and then amended to a Hawaiian acid soil at 2% and 4% alone or in combination with 2 cmolc/kg of lime. Their effects on soil properties and the growth of test plant (*Desmodium intortum*) were measured. The experiments were conducted twice in a greenhouse of the University of Hawaii at Manoa. The results indicated that upon biochar additions soil pH was increased, soil exchangeable aluminum was reduced, and plant nutrients were enriched variously, depending on the biochars' feedstock. Total dry weights of the test plant in biochar-alone treatments (2nd planting) increased 2-4 folds over the control or lime treatment. Such differential effects of biochars were attributed to the differences in ash content, pH, calcium carbonate equivalent, base cations and surface-functional groups. Four of the six biochars tested improved soil productivity and increased plant growth. Thus, we would recommend that biochars produced from lac tree (*Schleichera oleosa*), leucaena (*Leucaena leucocephala*), she oak (*Casuarina junghuhniana*) or Hilo mixed woods be applied at 2 to 4% in combination with a moderate quantity (1-2 cmolc/kg) of lime for soil productivity and plant growth improvements.

Keywords: biochar, soil productivity, exchangeable Al

INTRODUCTION

Biochar is the product of thermal decomposition or incomplete combustion of biomass under a limited supply of oxygen or by natural fire. Its production was inspired by the discovery of the anthropogenic Amazonian Dark Earth or Terra Preta, which had a higher nutrient content, cation exchange capacity (CEC) and organic matter than the surrounding soils (Lehmann *et al.*, 2002; Lehmann & Joseph, 2009). Recently, biochar has often been produced under a pyrolytic process for soil amendment or carbon sequestration (Lehmann and Joseph, 2009).

Since biochar can be produced from a variety of feedstocks and under different production processes and conditions, they have different physical, chemical and biological properties (Antal and Grønli, 2003); thus potentially having different effects when applied to soils. Singh *et al.* (2010) reported significant differences in pH, CEC, ash content, surface basidity and acidity, lime equivalent, nutrient content of 11

biochars made from wood, manure, leaf, papermill sludge, poultry litter produced under 400°C and 500°C pyrolysis temperatures, with or without steam activation. Keiluweit *et al.* (2010) also found wood pine biochar differed from tall fescue grass biochar in respect to their volatile matter (VM); fixed carbon; ash content; C, N, H, and O content; H:C and O:C ratios, and surface area. In addition, Mukherjee *et al.* (2011) observed a different surface chemistry represented by pH, VM, ash content, CEC, anion exchange capacity, point of zero net charge, zeta potential, isoelectric point and surface acid functional group distribution of oak, pine and grass laboratory-produced biochars at different pyrolysis temperatures. Such results show a need for biochar characterization before its use as a soil amendment or carbon sequester.

Biochar has been shown as a promising and environmental friendly soil amendment for sustainable agriculture and climate change mitigation (Glaser *et al.*, 2002). Recent investigations indicated that biochars can ameliorate several constraints of acid soils (Novak *et al.*, 2009; Singh *et al.*, 2010; Deenik *et al.*, 2011; Streubel *et al.*, 2011; Yuan & Xu, 2012). In addition to its liming potential, biochar can also improve soil CEC and the availability of plant nutrients, increase water holding capacity, reduce nutrient leaching, and reduce carbon emission (Novak *et al.*, 2009).

The capacity of biochar to increase soil pH and to reduce exchangeable Al depends on its ash and volatile matter content, which is affected by biochar's feedstocks and production process (Deenik *et al.*, 2011). Soluble salts, such as potassium and sodium carbonates and oxides, can cause an increase of pH in the water-film around biochar particles (Joseph *et al.*, 2010). However, the liming potential should not only be related to the ash content, but also to the surface functional groups of biochar. Hue (2011) reported that soil-solution Al was significantly complexed by crop residues applied to acid soils. Indeed, surface chemistry and reactivity of biochar is partly attributed to the presence of functional groups such as phenolic and carboxylic acids (Boehm, 1994; Rutherford *et al.*, 2008; Cheng *et al.*, 2008). The objective of this study is to characterize selected biochars produced from different feedstocks, and to investigate their capacities to improve the productivity of an acid soil.

MATERIALS AND METHODS

A. Biochar collection & characterization

Six biochars were collected from Indonesia and Hawaii. Five biochars were made by farmers in an open fire process with a broad range of temperature in West Timor, Indonesia. They are leucaena (*Leucaena leucocephala*), lac tree (*Scheichera oleosa*), she oak (*Casuarina junghuhniana*), mahogany (*Swietenia macrophylla*), and mountain gum (*Eucalyptus urophylla*) wood-derived biochars. The sixth was a mixed wood biochar produced by Landscape Ecology Corporation, Hilo, Hawaii. All coarse biochars were air dried followed by oven dried at 70°C for 48 h, crushed, sieved to pass through a 60 mesh sieve, and stored before used.

Biochar's pH was measured after biochar and deionized water (1:5) were mixed and equilibrated for an hour, while biochars EC were measured after 24 hour equilibration. Biochar moisture, ash and volatile matter contents were measured with the American Society for Testing and Materials (ASTM) method (D-1762-84) (ASTM, 1990). Biochar's CaCO₃ equivalent was determined by a rapid titration according to the

procedure described by Rayment & Higginson (1992). To measure functional groups on the surface of biochars, three procedures were used: (1) Fourier Transform Infra-red (FTIR) spectrometry, (2) solid state ^{13}C magic angle spinning nuclear magnetic resonance (MAS ^{13}C -NMR) as suggested by McBeath *et al.* (2011), (3) the Boehm titration method (Boehm, 1994).

Total carbon, nitrogen and hydrogen elements were determined using an elemental analyzer. Oxygen element was obtained by calculation. Other nutrients in biochars were read with an inductively coupled plasma (ICP) spectrometer after wet digested in an acid mix (70% of HNO_3 and 30% of HClO_4) at 150°C for 1.5 h.

Surface structure and porosity of biochars were measured with a scanning electron microscope (SEM). Cation exchange capacity of biochars was measured with the ammonium acetate (NH_4OAC) pH 7.0 method (Chapman, 1965).

B. Greenhouse experiments

To study the amending capacity of biochars, a greenhouse experiment was conducted using an acid soil, Ultisol order (Ustic Kanhaplohumults, Leilehua series), from Oahu, Hawaii, USA. Soil samples were air dried, and sieved to pass a 4 mm sieve for the pot experiment; and passed through 0.5 mm sieve for chemical analysis. In its natural state, the soil had a pH of 4.6, 2.4 cmolc/kg acidity, 1.8 cmolc/kg exchangeable Al, and 16.8 cmolc/kg CEC. The six biochars described above were used as amendments along with a hydrated lime (Bandini®) having a CaCO_3 equivalent of 108.

The treatments, consisting of biochars and lime, were arranged in a 6 x 3 x 2 factorial completely randomized design with 3 replicates. Biochar rates were: control (soil without biochar), 2% and 4%. The lime treatments were control (soil without lime) and 2 cmolc/kg. Each of two kg of soil was added with biochars and/ or lime, mixed, watered, and then transferred into pots. Basal nutrients were added to all treatments (mg/kg): 160 N, 160 P_2O_5 , and 160 K_2O from a 16-16-16 commercial fertilizer. After four weeks of incubation, all pots were planted twice with *Desmodium intortum* cv. Greenleaf, as the test plant. *Desmodium* was cut after 37 days. The shoots were cut and the roots were carefully removed from the soil. Both were washed with tap water and then with deionized water three times before oven-dried at 70°C and the dry weights were recorded. Soil samples were collected from each pot after four weeks of incubation, air-dried, crushed, and passed through a 0.5 mm sieve before analysis. Selected soil chemical properties, namely soil pH (H_2O 1:1), total acidity and exchangeable Al, were measured using the same methods described previously.

C. Statistical and analysis of data

Mean, standard error and regression coefficient were computed from three replicates data using Microsoft 2010 Excel software. Treatment effects on soil properties and plant growth were analyzed by a two-way analysis of variance using PROC ANOVA GLM of the SAS 9.2 software, and the Duncan's multiple mean comparisons at $P \leq 0.05$ were done for testing the significance of the treatments.

RESULTS AND DISCUSSION

A. Selected properties of biochars

Selected properties of biochars are shown in Tabel 1. Biochars' pH ranged from 4.2 to 10.4, and positively correlated with the ash content (Fig. 1a). There is also a positive correlation between CaCO_3 equivalent and base cations in the biochars (Fig.1 b). Biochars' EC ranged from 0.1 to 2.4 dS/m, their CEC varied from 13.9 to 45.1 cmolc/kg, and VM content from 22.9 to 55.3%. Total phenolic varied from 25.1 to 9,621.9 $\mu\text{g/g}$, with the highest content being from the mahogany and mountain gum biochars. Leucaena, lac tree, mix wood and she oak wood biochars had alkaline pH, high CaCO_3 equivalent and EC. In contrast, mountain gum and mahogany biochars, had acid to slightly acid pH, high CEC, volatile matter and total phenolic content.

Elements or nutrients content varied with biochar types (Table 2). Leucaena, lac tree, mix wood, and she oak biochars had higher content of N, P, Na, K, Mg, Ca, Si, Bo, Cu, Zn than mountain gum and mahogany biochars. The results seem to reflect the elemental content of the feedstock. The total C, H and O ranged from 55.2 to 71.2%, 1.0 to 3.0% and 26.4 to 43.2% respectively (Table 1); and calculated O:C and H:C ratios ranged from 0.2 to 0.6. Based on the O:C ratio and fix carbon content, the stability order of our biochars is leucaena < mahogany < mixed wood < lac tree \approx mountain gum \approx she oak. The results agreed with those of Spokas (2010) who proposed the O:C ratio as a key indicator of biochar stability. The reliability of O:C ratio as an indicator of stability was further supported by Crombie *et al.* (2013) who showed a strong correlation among three stability indicators (included O:C ratio) for pine wood, rice husk and wheat straw derived biochars.

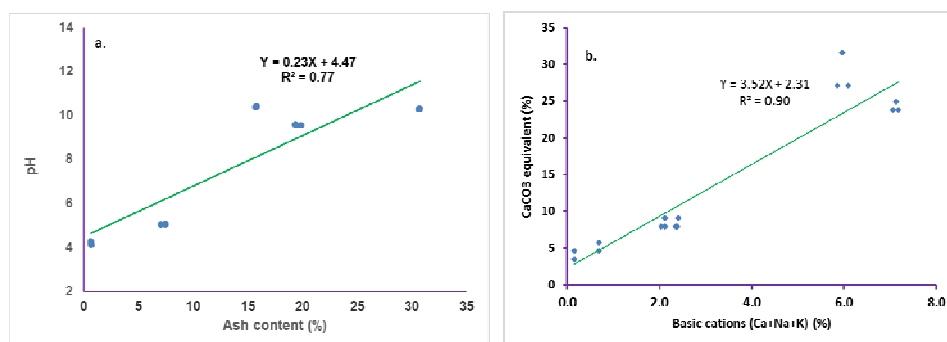

Figure 1. Relationships between pH and ash content (a) and between CaCO_3 equivalent and basic cations (b)

Surface functional groups of biochars measured by FTIR, NMR, and Boehm titration are shown in Fig. 2, Fig. 3, and Table 3, respectively. FTIR bands at 3400 cm^{-1} is assigned to OH stretch of phenol, while C-H stretching of aliphatic CH_x at $2800\text{--}2400\text{ cm}^{-1}$, C=O carboxylic and ketones at 1700 cm^{-1} , C=C stretching aromatic components and C=O conjugated ketones and quinones at 1600 cm^{-1} , aliphatic C-H bending vibration at 1420 cm^{-1} , C-H stretch at 1030 cm^{-1} , which is associated with undecomposed cellulosic and lignous C (cellulose, hemicellulose and lignin), and C-H bending aromatic CH out of plane deformation at 874 cm^{-1} . The peak intensity also reflects the quantity of surface functional groups shown in Table 3. The band of carboxylic groups (1700 cm^{-1}) for leucaena and lac tree biochars, for example, is nearly

disappeared in Fig. 2. These values are in agreement with those reported by Brewer *et al.* (2011), and Kloss *et al.* (2012). The small quantity of carboxylic groups obtained from Boehm titration for those biochars was consistent with our FTIR results. Quantity of phenolic groups was very high in the mountain gum and mahogany biochars. It was consistent with the total phenolic content obtained from the Prussian blue assay, broad bands FTIR at 1600 cm^{-1} , and Boehm titration.

NMR bands from the six biochars had similar patterns (Fig. 3). A typical aromatic band at the center and two symmetrical spinning side bands. The broad central band around 120-160 ppm is aromatic, and is the main component of biochar. This was the result of the rearrangement and aromatization of thermochemically degraded cellulose, hemicellulose and lignin during pyrolysis (Keiluweit *et al.*, 2010). The presence of aromatic compounds is supported by the FTIR peak at 1600 cm^{-1} and the low values of biochar H:C ratio. On the left side there are aldehyde (190-200 ppm) and a small band of carboxylic (160-170 ppm), while CH-O, CH-N, CH-X (70-90 ppm) and other aliphatics (10-30 ppm) bands are on the right.

SEM graphs show the porous nature of biochars (Fig. 4.). The ranges of pore size for leucaena, Hilo mixed wood, she oak, mahogany, lac tree and mountain gum biochars are 2.25-27.6 nm, 2.26-15.9 nm, 4.28-12.6 nm, 2.88-15.5 nm, 1.69-12.6 nm, and 2.24-6.92 nm respectively. They are of micropores (< 2 nm) and mesopores (2-50 nm). Porosity was developed from the rearrangement of fused-ring carbons during the heating process. The aggregated fused-ring carbons are stacked to form small lamellar crystallites, then the crystallites were randomly orientated that left voids between them (Rutherford *et al.*, 2004).

B. Soil pH

The addition of biochars at 2% and 4% alone or in combination with 2 cmolc/kg of lime raised soil pH varyingly, depending on types and rates of biochars (Fig. 5). Leucaena and lac tree biochars increased soil pH from 4.5 to 5.9 and 5.8, respectively when applied at 2%, and increased the soil pH further to 6.9 and 6.3, respectively at 4%. However, their capacity to raise soil pH were lowered when combined with lime. Hilo mixed wood and she oak raised the soil pH moderately. Mahogany and mountain gum biochars only increased soil pH slightly to 5.0 when applied with lime. The magnitude of soil pH increases well correlates with the biochars ash content (Fig. 6). This finding is in line with those of Deenik *et al.* (2011), Chintala *et al.* (2013), Butterly *et al.* (2013).

C. Soil Exchangeable Al

Type and rate of biochars affected soil exchangeable Al differently (Fig. 7). Soil exchangeable Al was decreased from 1.8 cmolc/kg to undetectable level by the addition of leucaena or lac tree biochars at 2%, and by Hilo mixed wood and she oak biochars at 4%. In contrast, mahogany and mountain gum biochars decreased soil exchangeable Al only when applied in combination with lime. The result is similar to that of Deenik *et al.* (2011) who reported that the kiawe charcoal was capable of increasing soil pH and reducing exchangeable Al in a Hawaiian Ultisol. Our finding is also consistent with those of Yuan & Xu (2012) in China, Singh *et al.* (2010) in Australia, and Yamato *et al.* (2006) in Indonesia. The liming capacity of biochars could be attributed to their

CaCO₃ equivalent (Fig. 8.) and surface functional groups. The mechanisms behind the neutralizing capacity of biochars are: (1) increasing soil pH and precipitation of solution Al by the presence of OH⁻ ion released from dissolution of organic & inorganic compounds from the biochars, and (2) complexing Al by insoluble oxidized organic functional groups, particularly carboxylics and phenolics at the surface of biochar (Joseph *et al.*, 2010; Yuan & Xu, 2012).

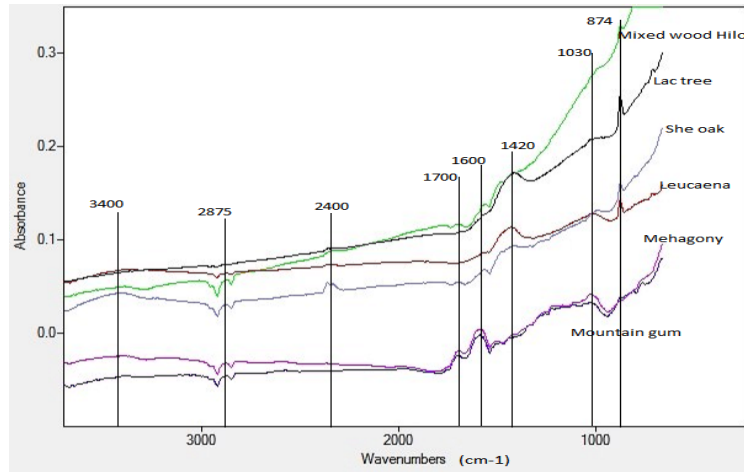

Figure 2. FTIR bands characterizing functional groups on the surface of 6 biochars

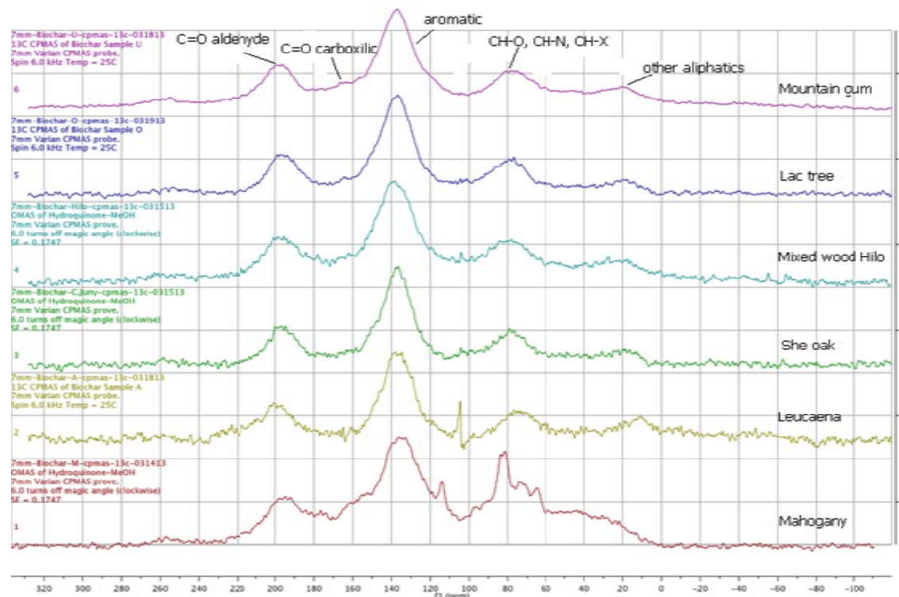

Figure 3. CPAS NMR peaks of the chemical compounds and functional groups of six biochars

Table 1. Mean and standard error of selected properties of 6 biochars

Biochars	pH	EC	CEC	CaCO ₃ eq	Phenolics	Ash	Volatile	Fix C	C	H	O	O:C	H:C
	1:5	dS/m	cmolc(+)/kg	%	µg/g	%	%	%	%	%	%		
Leucaena wood	10.3	2.1 ± 0.04	20.1 ± 0.5	28.6 ± 1.5	27.4 ± 0.8	30.7 ± 0.03	33.3 ± 1.2	35.9 ± 1.2	55.2 ± 0.6	1.0 ± 0.07	43.2 ± 0.6	0.59 ± 0.01	0.22 ± 0.01
Lac tree wood	10.4	2.3 ± 0.02	17.3 ± 1.3	24.1 ± 0.4	35.2 ± 0.3	15.8 ± 0.04	28.1 ± 0.03	56.1 ± 0.1	68.2 ± 0.9	1.4 ± 0.04	29.9 ± 0.9	0.33 ± 0.02	0.24 ± 0.01
Hilo mixed wood	9.5	2.4 ± 0.01	14.7 ± 0.2	8.4 ± 0.4	25.1 ± 0.2	19.6 ± 0.2	23.7 ± 0.5	56.7 ± 0.4	64.5 ± 0.9	1.5 ± 0.06	33.6 ± 0.9	0.39 ± 0.02	0.27 ± 0.01
She oak wood	10.2	0.9 ± 0.02	13.9 ± 0.6	8.4 ± 0.4	28.3 ± 0.5	4.6 ± 0.1	22.9 ± 1.8	69.8 ± 1.7	71.2 ± 5.1	2.0 ± 0.04	26.4 ± 5.2	0.30 ± 0.08	0.34 ± 0.02
Mahogany wood	5.0	0.1 ± 0.00	45.1 ± 0.5	5.0 ± 0.4	532.4 ± 7.5	7.3 ± 0.1	53.3 ± 1.0	39.3 ± 1.2	61.9 ± 1.6	3.0 ± 0.04	34.7 ± 1.7	0.42 ± 0.03	0.59 ± 0.01
Mountain gum wood	4.2	0.1 ± 0.00	44.9 ± 0.5	4.2 ± 0.4	9,621.9 ± 341.9	0.7 ± 0.0	36.4 ± 0.2	62.9 ± 0.2	69.1 ± 2.1	2.3 ± 0.09	28.3 ± 2.2	0.31 ± 0.03	0.40 ± 0.01

Table 2. Mean of concentration of selected elements in the biochars

Biochars	N	P	K	Ca	Mg	Na	Fe	Mn	Zn	Cu	B	Mo	Al	Co	Si
	%						µg/g								
Leucaena wood	0.6	0.08	0.85	5.1	0.55	0.03	3894.4	214.2	18.9	16.2	26.1	0.30	3710.8	0.04	38.1
Lac tree wood	0.3	0.13	0.73	6.3	0.32	0.06	571.0	87.9	15.1	10.1	12.7	0.04	448.1	0.00	45.7
Hilo mixed wood	0.5	0.09	0.47	1.6	0.22	0.35	12259.5	153.8	13.3	20.9	12.8	0.18	9766.9	0.06	15.7
She oak wood	0.3	0.01	0.50	1.5	0.11	0.08	284.0	41.9	5.1	5.2	8.4	0.38	129.4	0.01	58.8
Mahogany wood	0.2	0.01	0.17	0.5	0.12	0.01	2728.6	62.4	9.4	8.7	2.9	0.20	1779.2	0.02	28.3
Mountain gum wood	0.1	0.02	0.03	0.1	0.03	0.04	206.2	12.9	8.7	2.5	3.2	0.02	155.3	0.00	28.0

Table 3. Mean and standard error of functional groups on six biochars obtained by the Boehm titration

Biochars	Total	Carboxylic	Phenolic	Lactonic
	mmol/g			
Leucaena	0.38 ± 0.01	0.07 ± 0.02	0.21 ± 0.04	0.10 ± 0.03
Lac tree	0.38 ± 0.02	0.12 ± 0.02	0.20 ± 0.04	0.07 ± 0.02
Hilo mixed wood	0.58 ± 0.03	0.22 ± 0.02	0.27 ± 0.03	0.10 ± 0.03
She oak	0.43 ± 0.01	0.24 ± 0.01	0.06 ± 0.01	0.13 ± 0.01
Mahogany	2.64 ± 0.03	0.31 ± 0.01	1.57 ± 0.05	0.76 ± 0.03
Mountain gum	2.15 ± 0.03	0.55 ± 0.04	0.88 ± 0.04	0.72 ± 0.03

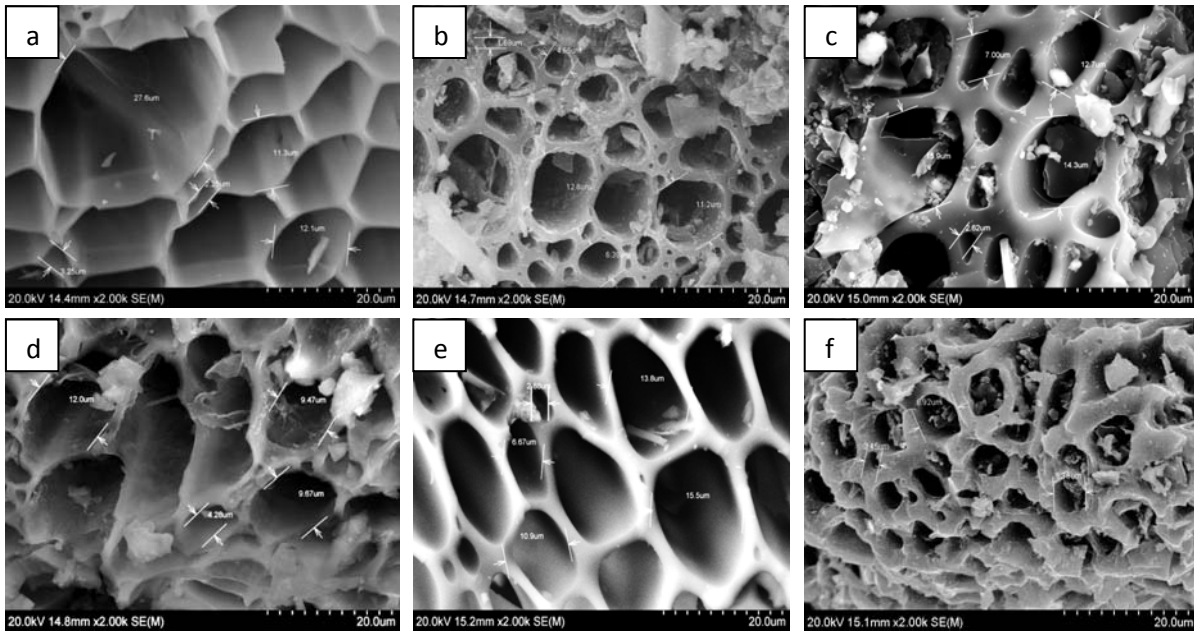

Figure 4. SEM graphs show the surface structure and porosity of six biochars
 a. *Leucaena* b. *Lac tree* c. *Hilo mixed wood* d. *She oak* e. *Mahogany* f. *Mountain gum*

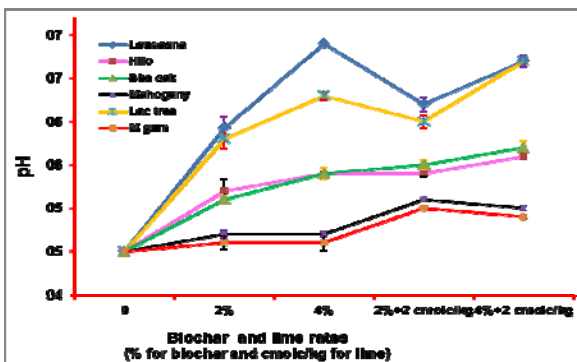

Figure 5. Soil pH as affected by biochar and lime amendments

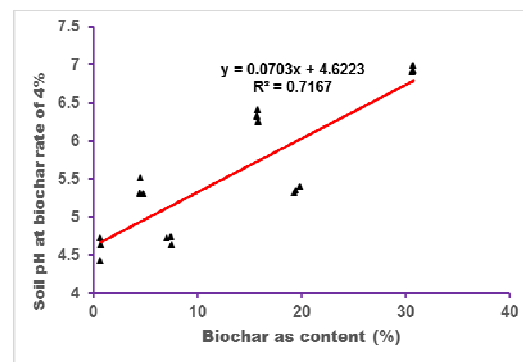

Figure 6. Correlation between biochar ash content and soil pH

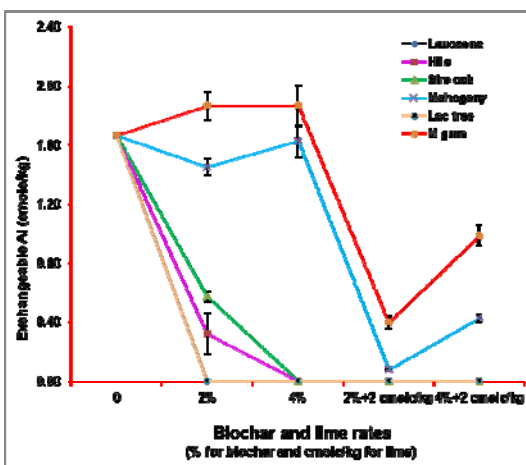

Figure 7. Soil exchangeable Al as affected by biochar and lime amendments

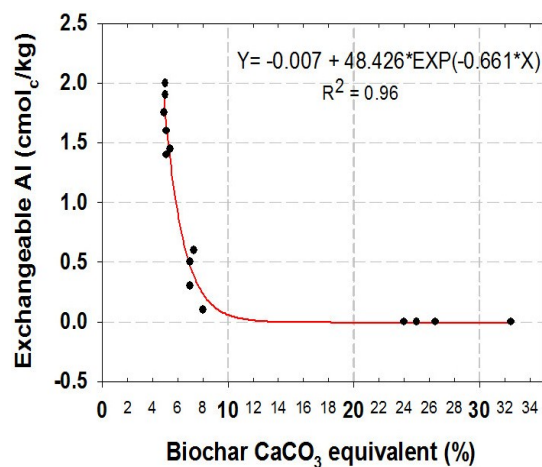

Figure 8. Correlation between biochar CaCO_3 equivalent and exchangeable Al in amended with 2% biochars

D. Plant dry weight

Total dry weight of *Desmodium intortum* increased with the addition of biochars (Fig. 9). The best growth in the first planting was obtained from the application of Hilo mixed wood, lac tree and she oak at 2% and mahogany at 2% with lime (data not shown). In the second planting, the best growth was obtained from the application of leucaena, lac tree and she oak biochars at 4%. Such growth enhancement could be attributed to the reduction of Al toxicity, increases in soil pH, soil CEC and nutrients upon biochar incorporation. The combination of biochars and lime depressed plant growth in the second planting for nearly all biochars tested, perhaps due to the over liming effects.

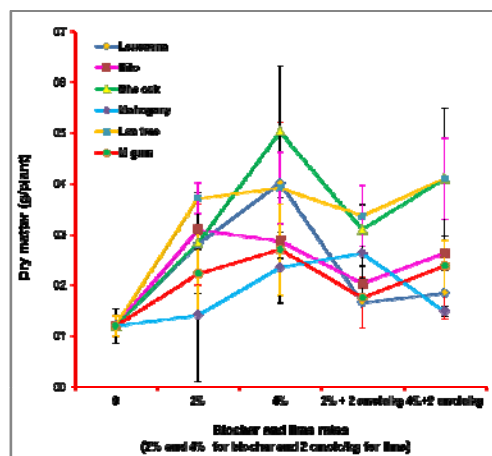

Figure 9. Dry weight of *D. intortum* as affected by biochar and lime applications (Second planting)

CONCLUSIONS

Biochar characterization of physicochemical properties allowed us to choose appropriate biochars for improving soil productivity and enhancing plant growth. Six biochars derived from different woody materials were quantitatively showed differences in ash, volatile matter, fix C, total C, H, N and O, O:C and H:C ratios, pH, calcium carbonate equivalent, CEC, EC, elemental content, surface functional groups, and surface structure and porosity. The higher capacity to improve soil productivity and to support plant growth of leucaena, lac tree, mixed wood, she oak wood derived biochars than mahogany and mountain gum biochars could be predicted from their measured properties. More specifically, the additions of leucaena, lac tree, mixed wood or she oak derived biochars at 2-4% clearly increase soil pH, and lowered exchangeable Al to a nontoxic level, thereby increasing *Desmodium intortum* growth.

ACKNOWLEDGMENTS

This paper is produced with a significant contribution from Dr. Nguyen V. Hue as my principal advisor. Equally significant supports came from the DIKTI scholarship, and helps from Dr. Jun Wang for FTIR analysis, Dr. Walt Niemczura for NMR records and interpretation, Dr. Rebecca Briggs for CHON analysis, Ms. Tina Carvalho for SEM and EDS records, and Mr. X. Huang for ICP spectroscopy analysis.

REFERENCES

- Antal MJ and Grønli M. 2003. The art, science, and technology of charcoal production. *Ind. Eng. Chem. Res* 42:1619-1640.
- ASTM, 1990. Standard method for chemical analysis of wood charcoal. ASTM:292-293.
- Boehm H P. 1994. Some aspects of surface chemistry of carbon blacks and other carbons. *Carbon* 32:759-769.
- Brewer CE, Hu Y, Schmidt-Rohr K, Loynachan TE, Laird DA, and Brown RC. 2011. Extent

- of pyrolysis impacts on fast pyrolysis biochar properties. *J. Environ. Qual.* 41:1111-1122
- Butterly CR, Baldock JA, and Tang C. 2013. The contribution of crop residues to changes in soil pH under field conditions. *Plant Soil* 366:185-198.
- Chapman HD. 1965. Cation exchange capacity. In: Black CA (ed): Methods of soil analysis Part 2, No. 9 in the series Agronomy. Madison (WI): *Am. Soc. Agron.* p. 891-901.
- Cheng C-H, Lehmann J, and Engelhard MH. 2008. Natural oxidation of black carbon in soils: Changes in molecular form and surface charge along a climosequence. *Geochim. Cosmochim. Acta* 72:1598–1610.
- Chintala R, Mollinedo J, Schumacher TE, Malo DD, and Julson JL. 2013. Effect of biochars on chemical properties of acidic soil. *Arch. Agron. Soil Sci.* 1-12.
- Deenik JL, Diaraa A, Uehara G, Campbell S, Sumiyoshi Y, and Antal MJ. 2011. Charcoal ash and volatile matter effects on soil properties and plant growth in an acid Ultisol. *Soil Sci.* 176:336-345.
- Glaser B, Lehmann J, and Zech W. 2002. Ameliorating physical and chemical properties of highly weathered soils in the tropics with charcoal-a review. *Biol. Fert. Soils* 35:219-230.
- Hue NV. 2011. Alleviating soil acidity with crop residues. *Soil Sci.* 176:543-549
- Joseph S D, Camp-Arbeistain M, Lin Y, Munroe P, Chia C H, Hook J, van Zwieten L, Kimber S, Cowie A, Sing B P, Lehmann J, Foidl N, Smernik R J, and Ammonette J E. 2010. An investigation into the reaction of biochar in soil. *Aust. J. Soil Res.* 48:501-515.
- Keiluweit M, Nico PS, Johnson MG, and Kleber M. 2010. Dynamic Molecular Structure of Plant Biomass-Derived Black Carbon (Biochar). *Environ. Sci. Technol.* 44:1247-1253
- Kloss S, Zehetner F, Dellantonio A, Hamid R, Ottner F, Liedtke V, Schwanninger M, Gerzabek MH, Soja G. 2012. Characterization of slow pyrolysis biochars: effects of feedstocks and pyrolysis temperature on biochars properties. *J. Environ. Qual.* 41: 990-1000.
- Lehmann J and Joseph S. 2009. Biochar for environmental management-science and technology. *Earthscan*. London.
- McBeath AV, Smernik RJ, Schneider MPW, Schmidt MWI, and Plant EL, 2011. Determination of the aromaticity and the degree of aromatic condensation of a thermosequence of wood charcoal using NMR. *Org. Geochem.* 42: 1194–1202.
- Mukherjee A, Zimmerman AR, and Harris W. 2011. Surface chemistry variations among a series of laboratory-produced biochars. *Geoderma* 163:247-255.
- Novak JM, Lima I, Xing B, Gaskin JW, Steiner C, Das KC, Ahmedna MA, Rehrh D, Watts DW, Busscher WJ, Schomberg H. 2009. Characterization of designer biochar produced at different temperatures and their effects on a loamy sand. *Annals of Environmental Science* 3:195-206.
- Rutherford DW, Wershaw RL, and Cox LG. 2004. Changes in Composition and Porosity Occurring During the Thermal Degradation of Wood and Wood Components. *U.S. Geological Survey Scientific Investigations Report* 2004-5292.

- Rutherford DW, Wershaw RI, and Reeves III JB. 2008. Development of acid functional groups and lactones during the thermal degradation of wood and wood components. *U.G. Geological Survey Scientific Investigations Report 2007-5013*.
- Singh B, Singh BP, and Cowie AL. 2010. Characterisation and evaluation of biochars for their application as a soil amendment. *Aust. J. Soil Sci.* 48:516-525.
- Spokas KA. 2010. Review of the stability of biochar in soils: predictability of O:C molar ratios. *Carbon Manage.* 1: 289-303.
- Yamato M, Okimori Y, Wibowo IF, Anshori S, and Ogawa M. 2006. Effects of the application of charred bark of *Acacia mangium* on the yield of maize, cowpea and peanut, and soil chemical properties in South Sumatra, Indonesia. *J. Soil Sci. Plant Nutr.* 52:489-495.
- Yuan JH and Xu RK. 2012. Effects of biochars generated from crop residues on chemical properties of acid soils from tropical and subtropical China. *Soil Research* 50:570–578.

LAND MANAGEMENT SALAK PONDOH (*Salacca edulis Reinw*) ESPECIALLY BASED ON ALTITUDE AT TURI SLEMAN

Subroto Padmosudarso

Department of Agrotechnology , UPN "Veteran" Yogyakarta, Indonesia

subroto_ps@yahoo.co.id

ABSTRACT

Land is a whole number of natural resources, referred to the climate, geology, soils, vegetation, fauna and water. Salak Pondoh is one variety of salak (*Salacca edulis Reinw*) that has gained popularity in the last decade, the fruit has a specific taste and aroma, contains a high calcium that beneficial for bone growth. Salak Pondoh developed in Turi very fast and almost all agricultural land has been used for Salak Pondoh cultivation without exception paddy field. Paddy field as a source of methane gas which contribute increased heat of the earth. Paddy field changes to Salak Pondoh land is expectedly being more friendly to the environment. Salak Pondoh has a thick and stiff leaf morphology and a thorny stem which very useful in conserving of soil and water. Midrib prickly with thorns which is more tightly near the base stem may control the speed of the rain water flow. It is useful in regulating soil moisture. Salak Pondoh land in Turi is divided into three altitude. At an altitude of 350-450 m above sea level, it produce a good on especially quality fruit but the fruit is small, at an altitude of 450-650 m above sea level, it produce a good on generally quality fruit and fruit has big size, at an altitude of 650-900 m above sea level, Salak Pondoh produce not so good quality fruit has big in size. Based on the above description the Salak Pondoh land management particularly based on altitude needs to be improved and maintained for its sustainability.

Keywords: *Salak pondoh, land, management, altitude*

INTRODUCTION

Land is a whole number of natural resources, which include vertical rows from the atmosphere through the weathering layer lithosphere. Natural resources are referred to the climate, geology, soils, vegetation, fauna, and water (Notohadiprawiro, 1978). Land component discussed in this paper are mainly focused on altitude, moisture, and temperature.

Salak Pondoh is one variety of salak (*Salacca edulis Reinw*), that has gained popularity in the last decades. This variety has many advantages over the other varieties already known in Indonesia. The fruit does not cause constipation and stomach ache, though eaten before taking meal and in a big quantity. Besides it has a specific taste and aroma,

sweet without bitterness in spite of the unripe on. The fruit contain a lot of calcium, the substance have very much needed for human bone growth (Padmosudarso, 2000).

Principally Salak Pondoh has four phases of growth : (1) The planting phase since the start of cropping up root and leaf expansion (2) Phase of formation and enlargement of clumps or stems (3) Generative phase that marked by the emergence of flower, plant age of 2,5 - 3 years (4) The end phase, the phase formation is estimated to be 1-7 months starting from pistil formation until harvest (Suprayitno, 1995).

RESULT AND DISCUSSION

Population growth of Salak Pondoh at Turi Sleman was increased very fast. Much low productive land that was originally was planted with Salak Pondoh but now all was planted with Salak Pondoh and almost no land left. E ven too much rice fields have been changed to Salak Pondoh land, it is because Salak Pondoh is more promising as well as Salak Pondoh can also help to create a friendly environment. Salak Pondoh has a very important role : (1) Thick and pinnate leaves that grow on the stem, the leaf is are able to withstand the blows rain water so that the soil is not damaged, and have an influence on the decrease in evaporation, so it helps in the conservation of soil and water (2) Salak Pondoh have spines that number and more and more structure down getting close to the base of the stem which controls the speed of meeting water dripped to the ground, with more spines meeting the slower water speeds which means it can maintain better soil moisture, causing the below Salak Pondoh time of the year in a moist condition.

Climate is one very important factor in the growth process and plants production. Each farm has a direct relationship with climatic factors. Enormous influence of climatic factors on the growth and yield (Lakitan, 1994), as well as the role of climate for Salak Pondoh can influence the quantity and quality of fruits.

Physical and chemical processes controlled by temperature, and then it controls biological reactions that take place in the plant. Temperature determines the rate of diffusion of gases and liquids into the plant. When the temperature droppds, the water viscosity will increase. Likewise gase, the kinetic energy of the carbon dioxide, oxygen and other substances may change with temperature.

Temperature dependent solubility of various substances were as follows carbon dioxide solubility in cold water twice from hot water solubility. The converse applies to most solids, sugar has a greater solubility in hot water than cold water.

Reaction rate is influenced by temperature, usually the higher the temperature, the faster the reaction. Temperature has a significant effect on respiration.

Temperature affects the stability of the enzyme system. At the optimum temperature, enzyme systems function well and remain stable for a long time. At cold temperatures, they remain stable, but it does not work, while the high temperature defective enzyme system at all.

Temperature also has a strong influence on the reaction of plant biochemistry and physiology. It will also determine the level of various crops tasks suc as absorption of mineral elements in water. Higher water viscosity at low temperatures, but the

cytoplasm membrane through which the water is less permeable. Photosynthesis is more slowly at low temperatures, and consequently slower growth rate. Temperature

The maximum and minimum temperatures that promote plant growth is usually around 5° C - 35° C. Temperature for optimum growth is vary depending on the plant and vary according to the stage of developments. Various parts of different plants are sensitive to minimum temperature. Plants that have adapted to the cold climate, its roots are more sensitive to low temperatures than stems. Flower buds are weaker than leaf buds.

A number of processes growth have relation with temperature. Including respiration, photosynthesis and some of the reactions of various symptoms of maturation and ripening. Processes in plants such as dormancy, flowering, fruit formation, is very sensitive to temperature. Most plants require a night temperature lower than the temperature of daylight. Some plants require cold temperatures to complete the circle of life .

Extreme temperatures can damage the crop. Temperatures that are too cold and freezing temperatures or too hot/high can kill plants. Damage due to high temperatures can be attributed to drought (desiccation). Burning plants as the weather is too hot / high, usually the result of water loss in transpiration activity is too much when compared with the absorption of water. Cessation of growth at high temperatures is a picture of a disturbed metabolic balance. When the respiration rate increases faster than the speed of photosynthesis, it will result in food shortages in plant body.

Plants grown without light but were given food source of spare places will be yellow and have a very long stem and thin. In plants that are obtain light will form a green color in contrast to the formation of chlorophyll and stimulation photosynthesis, and get a normal structure. Light can affect the distribution and synthesis of auxin. Some anthocyanin pigments that can be formed also requires light. Cool bright light conditions favor conversion of starch into sugar, which then become available for the synthesis of the red pigment, this is anthocyanin. In the cold night time outlined chlorophyll, carotenoid pigments appear yellow more stable. Influence of light on plant growth is often associated with the duration of irradiation and darkness (photoperiod).

The rate of photosynthesis relate to the availability of raw materials, namely water and carbon dioxide, and the energy available in the form of heat and light. The rate of photosynthesis is greatly reduced during dim light, when the sky is overcast. But not all plants have a response to high light intensity. Some require only one-tenth of full sunlight.

Salak plants can grow at altitude of 0-900 m above sea level, rainfall 200 -400 mm / month and monthly average more than 100 mm, the sun needs 50-70 % , the daily temperature between 20-35° C, the Salak plant will grow well, at a temperature of more than 35°C, the growth will be stunted (Anonim, 1992).

The quantity of Salak Pondoh production needs to be related with the quality of the productt. As for determining the quality frutt divided into two, namely: (1) The quality of the frutt in general, and (2) quality of the fruit specific. Quality of frutt are generally determined by visually assessment that can be seen by the eye senses, such as fruit size, fruit uniformity and deformed fruit, and the organoleptic assessment which can be perceived by the senses in addition to the eye of taste, aroma, crispness ..

According to Padmosudarso, (2000), Salak Pondoh land altitude in Turi Sleman was divided into three locations, namely : (1) Altitude 300-450 m above sea level is called the low land : (2) Altitude 450-650 m above sea level called middle land, (3) Altitude 650-900 m above sea level called the up land.

Based on the altitude, in general quality of fruit from the middle land is better than one from the up land and from low land, Meanwhile fruit from up land is better than one from the low land. For the specific quality of fruit, salak from the low land is better than from the middle land and from the up land, while from middle land is better than from the up land. Salak Pohon from the up land generally has a rather large size, rather uniform and without a lot defects. The specific quality of its fruit rather sweet, less smell, less crisp, and not sour. Middle land fruit quality generally, almost uniformly, large fruit size and not a lot of defects, specific quality of fruit is sweet, aroma somewhat crisp, little less sour. Low land fruit quality generally small fruit size was not much deformed rather uniform, in specific quality of fruit, is strong aroma, crisp and slightly sour. To assess the fruit of Salak Pondoh it was used Panelist Method

A. Generally Land Management

Salak Pondoh at Turi Sleman is basically fit and can grow well and produce fruit in adequate quantity and in quality, This means that in general land component in Turi Sleman have a good role to the growth and development of Salak Pondoh itself, Each land component provides customers and mutual support between each other.

Salak pondoh as a component of land then can be produced in a good to very good quantity and quality of the fruit is good to very good as well as grow and develop properly, Salak Pondoh also has a good role to the environment and the Salak Pondoh itself. Salak Pondoh have a thick leaf morphology that function to withstand blows and of rain water. They have spines that the number structure more and more dense down / getting close to the base of stem. It can keep the soil humidity, so the water is always adequate. Water requirement is supported in Turi Sleman from rainfall that almost throughout the year. Climate components in Turi Sleman especially rainfall, and temperature humidity has a good role, specific temperature and humidity will be discussed separately in section particular land management .

Land component at Turi Sleman covering three types of soil those Entisol, Inceptisol, and Andisol. Salak Pondoh can grow well on these three types of soil. Regarding soil texture ranged slightly coarse to coarse so that Turi Sleman soil drainage is good to very good. Under high rainfall in Turi Sleman it can be overcome with good drainage.

The main components of topographic are elevation and slope. At Turi Sleman soil and plant support for the growth of plants to cope with heavy rainfall. However in the slope land it was still being made terraces and garden bed. Regarding altitude will be discussed more detail in section special land management.

As above mention water component can be an important component for the growth and development Salak Pondoh. It is also well supported by the springs coming from Mount Merapi, which flows throughout the year.

Generally land management, human resource as a land manager basically lived maintain land and preserve land resources optimizing well with the results of the use of land in accordance with the principle of land capability.

B. Specifically Land Management

Land management in accordance with the title is specifically overview the land components related to altitude, temperature, and humidity influencing the Salak Pondoh production.

Land management in particular are essentially should be paid for attention : 1) The altitude, temperature, and humidity. Salak Pondoh land in Turi Sleman at three location/altitude indicate the temperature and humidity are different.

Up land average temperature is 19°C per year and humidity is 96.6 % per year. Middle land average temperature is 22.37°C per year and humidity is 83.48 % per year. Low land average temperature is 24.37°C per year and humidity is 72.18 % per year. 2). Fruit quality based on altitude. Fruit quality at the middle land in general is better than one from the up land and low land, while one from up land is better than low land. Specific quality of fruit from low land is better than fruit from middle land and up land, the fruit from middle land is better than from up land. After considering the altitude factor to do with the fruits there for the specific land management directioned focused on the best fruit according to general quality are best located in the middle land. Whereas the best fruit according to specific quality are best located in the low land. It is because the best quality in general and in specific term is the Salak Pondoh that is desired by consumers. Then land management for up land is directed to middle land in order that temperature and humidity close to temperature humidity at the middle land. The hope quality of fruit in general or specific will be approaching the quality fruit in general or in specific in the middle land.

Salak Pondoh land management needs to be maintained and preserved naturally. The enhanced research related to improvement of fruit quality in general and in specific term should be encouraged.

CONCLUSIONS

- A. Land component in general and particularly elevation of Turi Sleman, is suitable for Salak Pondoh. On the middle land Salak Pondoh produce fruit in the best general quality, while on the low land Salak Pondoh produce fruit in the best specific quality. Both of these qualities are quality of Salak Pondoh desired by consumers.
- B. Land management in general and in particular, be keep and cultivated in accordance with land capability and suitability for middle land and low land. For the up land management be directed to middle land so that the temperature and humidity is set in such a way that up land has temperature and humidity as middle land has, with the hope that fruit quality of Salak Pondoh will close to the fruit quality of Salak Pondoh from the middle land.
- C. Should be encouraged research on particular Salak Pondoh to improve the quality of the Salak Pondoh.fruit.

REFERENCES

- Anonim. 1992. Daftar komposisi Bahan Makanan. Direktorat Gizi Departemen Kesehatan R.I. Bhatara. Jakarta
- Lakitan, B. 1994. Dasar-dasar Klimatologi. PT. Raja Grafindo Persada. Jakarta.
- Notohadiprawiro, T. 1978. gatra Fisik dalam Penyajian Lahan Kritik Dalam Lahan Sumber Daya Alam Serbagatra dan lingkungan Hidup Manusia. Departemen Ilmu Tanah. Fakultas Pertanian .Universitas Gajah Mada. Yogyakarta.
- Padmosudarso. S. 2000. Kesesuaian Lahan Salak Pondoh di Kecamatan Turi Sleman DIY. Universitas Gajah Mada. Yogyakarta.
- Supriyatno Imam. 1995. Budidaya Salak Pondoh. CV. Aneka. Solo.

DEVELOPMENT OF PURWACENG (*Pimpinella pruatjan* Molkenb) TO SUPPORT HERBS INDUSTRY AND SOIL CONSERVATION IN DIENG PLATEAU, CENTRAL JAVA

Partoyo^{1*}, Eko Amiadji Julianto¹, M. Husain Kasim¹, Teguh Kismantoroadji², Indah Widowati² and Sumino³

¹ Program Study of Agro-technology, Faculty of Agriculture,

² Program Study of Agribusiness, Faculty of Agriculture, Universitas Pembangunan Nasional "Veteran" Yogyakarta Jl. Lingkar Utara Condongcatur, Yogyakarta, INDONESIA

³ Indonesian Arts Institute, Jl. Parangtritis, Sewon, Bantul, Yogyakarta, INDONESIA

* Corresponding author: partoyo@upnyk.ac.id

ABSTRACT

Purwaceng is a multipurpose crop for development of green agro-industry, since it will support the demand of agroindustry of herbs as well as conserve soil from erosion. Purwaceng (*Pimpinella pruatjan* Molkenb) is a herbal plant that is popular as Indonesian herbs used as aphrodisiac, diuretic, and tonic. Its root contains substance that is believed beneficial to boost stamina and sexual endurance. Nowadays, the purwaceng get a high price due to lack of supply whilst demand from the herbs industry has never been fulfilled. Unfortunately, the plant is considered as endangered species that is endemically found particularly in Dieng Plateau. In 2013, the plant gained patent for the Dieng Plateau as Geographic Indication of purwaceng. Extensive cultivation of the plant in a wider area of Dieng Plateau and its surroundings is very promising. For the last two decades, Dieng plateau has been utilized for potato cultivation that contributed to the horrible soil erosion problem. The said farming practice is contradictive to the soil conservation rule. It is on this premise that planting of purwaceng can be very useful to counter the effect of environmental degradation issue in the Dieng Plateau. This is due to its morphological and physiological characteristics, where purwaceng may be cultivated as cover crop for bare land as well as mixed cropping under tree shading. It will reduce run off of rainfall water and increase infiltration that in turn will reduce soil erosion. This paper will discuss efforts that should be done to promote purwoceng for increasing production as well as reducing soil erosion in Dieng Plateau.

Keywords: *Pimpinella pruatjan*, herbs, agro-industry, soil conservation, Central Java.

INTRODUCTION

Dieng Plateau is one of Indonesia's tourism destinations. It is located in the border of two regencies, i.e.: Banjarnegara and Wonosobo Regency where most of the areas are developed for agricultural activities. During its development, this area has become the centre of agricultural development centre for plantation and tourism area in Central Java Province. Tourism activities itself is contributed in a significant manner of income to the farm household as this area has formerly been one of the Hindu empire in Indonesia (Saputro, 2012). Dieng Plateau is the second tourism destination in Central Java Province after Borobudur temple (Yuwana, 2010).

On the other hand, due to its physical environmental characteristics this area has been also developed as the agricultural production centre for vegetables and potato production in Central Java. Dieng has been popular as center of potato cultivation since 1990s. Area of land planted with potatoes was expanded tremendously, even occupied forest land. According to Rudiarto & Doppler (2013), deforestation in this area is mainly caused by land clearance as many local people have been expanded their farmland up to the higher-level area. It is also confirmed from the field survey that deforestation was seriously taking place and hence increasing the risk of land degradation, which may accelerate soil erosion.

In addition, some practices of potato cultivation are contradictive to soil conservation rule. Several researchers reported a high rate of soil erosion that exceeded the tolerable soil loss. Rudiarto & Doppler (2013) reported the annual soil loss rate changed from 0 until 1096 tons/ha/year for the year 1991 and 0 up to 1063 tons/ha/year in 2006. From the results of actual soil loss, afterwards, the classification has been made to show different erosion hazard levels, which more than 40% area included as very high hazard severity.

Currently, the hegemony of potato cultivation is declining. Beside of its negative impact to the environment, many farmer households faced with fund deficit. Actually, potato cultivation is very expensive. It required a high input of capital. At present, many farmers have switched to cultivate many other horticulture crops, such as carrot, cabbage, cauliflower, and leek. Some of them were back to develop local specific crop, i.e. carica, kemar, and purwaceng. All the three crops are usually processed for drink, syrups or refreshment. They are popular as specific souvenir for Dieng Plateau visitor.

Considering economic value as well as environmental benefit, development of those local crops is very promising. Presently, it is still in the stage of promotion to motivate the local people/farmer to be interested in developing carica, kemar, and purwaceng as the re-emerged commodities from Dieng Plateau. This paper is authored by the research and development team for community service conducted in Kejajar Wonosobo, particularly the development of purwaceng crop at area of Dieng plateau and the surroundings.

General Situation of Kejajar District, Wonosobo Regency

Kejajar is a district in Wonosobo Regency which is located at the highest altitude and dominated with mountainous area. It covers 5,762 hectares or approximately similar to 5.85% area of Wonosobo Regency. Dieng Plateau is included in this district. Altitude of the

district ranges from 1,360 to 2,302 m above sea level. It has a tropical climate with two seasons in a year, i.e. dry season and rainy season. Air temperature ranges from 14 – 23 °C in the day and drop to 9 – 18 °C in the night. Annual rainfall is recorded more than 2,500 mm. This condition is favorable for the development of horticultural agriculture, as well as tourism and plantation.

The main livelihood of the community is especially from horticultural agriculture and tourism sector. It has been famous that Kejajar is area of horticulture production in Central Java. Several commodities cultivated in Dieng are potato, cabbage, carrot, and cauliflower. All those crops are cultivated very intensively using high level of pesticide application and deep soil tillage. It is very endanger the sustainability of soil and the environment. Besides, during 1990s, many farmers were illegally occupied state forest to be cleared and used as potato plantation. It happened due to the high economic return from cultivating potato. At that time, land use of Kejajar was dominated by dry agricultural land of 3,066.3 ha (53.21%) and state forest of 2,309.8 ha (40.08%).

Deforestation has resulted in barren critical land that produces very high incident of soil erosion. Most of land in Kejajar is sloping area that predominantly has steepness of 15 – 40% for 1,993ha (65% area). Agricultural land in Kejajar covers approximately 3,500 hectares including this steep land or even more than 40% steepness. This situation induces a more serious damage due to soil erosion.

Population based on census 2010 recorded that Kejajar is inhabited by 40,925 peoples, consists of 20,987 male and 19,938 female. Population density is 710 people per square meters. Population growth is 0.42% per year.

ECONOMIC POTENTIAL OF PURWACENG CULTIVATION

Sikunang is one of the villages in Kejajar district that has potential for purwaceng cultivation. It is located in the Dieng Plateau. Purwaceng has been domesticated by Mr. Mubasir since 1970s. Later, purwaceng has gained better economic value since 1981, after raised consumer need for herbal material. However, number of farmers who developed purwaceng is remain very few until now (2013).

Several constrains of purwaceng development are scarcity of seedlings. It was not extensively available the seedlings that can be gather from the wildlife. Purwaceng may only be found in the area with the altitude more than 2,000 m above sea level. Besides, harvesting time of the purwaceng is 5-8 months after planting. It is long enough for the farmer awaiting the crop to be harvested.

In fact, presently the market of purwoceng has been available, either for fresh purwoceng or dry purwoceng/simplisia. Demand of purwaceng from herb industry in Semarang has not been able to fulfilled yet. Productivity of purwaceng is 9kg fresh purwoceng per 10 square meters of land. After drying, a 10kg fresh purwoceng produces 1kg dry simplisia. Economic potential of purwaceng cultivation is very beneficial. Now, the price of fresh purwaceng is Rp 80,000/kg, while dry simplisia is Rp 600,000/kg.

Low production of the purwaceng from the study area is mainly due to less area used for cultivation, lack of seedling, and low productivity due to not intensive practice of cultivation applied. Therefore, the author team is conducting activities to overcome those three constraints.

THE USE OF PURWACENG FOR HUMAN HEALTH

Purwaceng (*Pimpinella pruatjan* Molkenb. or *Pimpinella alpina* Molk.) is one of endangered species of herb plant that is endemically found in Indonesia. Purwaceng in Wonosobo Regency has only found in Dieng Plateau with the altitude 2,000 – 3,000 meter above sea level. At present, the population is very scarce. It is categorized as critical that has to be strictly conserved (Rivai *et al.*, 1992). Besides in Dieng, purwaceng was also ever found at Gede Pangrango mountain (West Java) and in Anjasmoro mountain although presently it is not clearly traced (Darwati dan Roostika, 2006).



Figure 1. Sample of harvested purwaceng, including, flower, shoot and root.

Purwaceng is a herb plant having effect of increasing motorical activity and tonic of muscles. According to Rahardjo (2003), root of purwaceng is useful as herbs of aphrodisiac (enhancing sexual endurance and inducing erection), diuretic (facilitating urination), and also as tonic (increasing stamina) (Hernani, 2004).

At present, wild purwaceng has been become more extinct. It was due to largely sought of the plant without any regeneration. Besides, forest plundering, deforestation, and forest conversion to agricultural land have devastated habitat of purwaceng. A massive exploitation of wild purwaceng was motivated by high price of purwaceng as long as increased demand from the consumer. They did not like to cultivate the plant, but hunting to the forest and field.

Considering high rate of purwaceng extinction, therefore it is required an effort for conservation. This research is going to awaken people in Kejajar to get economic benefit from the purwaceng concurrently with conservation effort for the environment. Attempt to cultivate in situ has not been carried out by the people yet. It was due to lack of seedling availability and information about cultivation practices.

POTENTIAL OF PURWACENG FOR LAND CONSERVATION

Purwoceng plant is a shrub that may grow to cover soil surface. The plant habitus, leaf morphology, and stem structure are suitable to be used as land cover crop. The taxonomy of purwaceng is as follow (Rahardjo, 2003):

Divisio : Spermatophyta
 Sub division : Angiospermae
 Class : Dicotyledoneae
 Ordo : Apiales
 Familia : Apiaceae
 Genus : *Pimpinella*
 Species : *Pimpinella pruatjan*

It is a multiple benefit of development of purwaceng cultivation in order to get economic value of the plant, as well as conservation benefit for the plant germplasm itself and for soil conservation. From the theoretical side, reducing soil erosion by using purwaceng as soil cover crop is one application of vegetative methods for reducing soil erosion.



(a)

(b)

Figure 2. Morphology of purwaceng plant at open land (a), and shaded land (b)

Selection of purwaceng as soil cover crop is appropriate at least according to two reasons. Firstly, purwaceng has a long growth periode. It tightly covers up soil surface that protect the soil from rain water droplet. In the rainy season, it has a dense leaves. The plant can be harvested during the dry season after age of 5-8 months. Harvesting was done for the mature plant while the young plant was remained to be left. By this way, soil surface was continuously covered by the plant. Secondly, the land that has been planted with purwaceng is not need to be replanted. The plants will regenerate itself by the seed. Self regeneration is naturally occurred from the fallen seed, that especially germinating during rainy season. The seed is continuously germinating in succession, therefore it is always purwaceng plant exist covering the soil.

Regarding the existing situation captured from on field survey and interview in Kejajar, it has been prepared activities to develop purwaceng crop. The potential use of purwaceng in Kejajar district can be optimized by conducting the following efforts:

1. Production of purwaceng seedlings.

This step is the preliminary effort to boost population of purwaceng crop. Research of Syahid *et al.* (2004) showed success of tissue culture for seedling production. It can be used for mass production, in spite of conventionally technique from the seed. Seedling produced in Kejajar is shown in Figure 3.



Figure 3. Purwaceng seedling originated from seed

2. Increasing area of purwaceng planting.

Increasing cultivated area will increase production volume of purwaceng. Additional area can be gained from shaded area under stand of carica crop and kemar crop. It will be beneficial to reduce soil erosion and increase economic return upon multi cropping land.



Figure 4. Cultivation of purwaceng under shading of carica and kemar crop

3. Improvement of cultivation technique of purwaceng.

In order to avoid chemical contamination, purwaceng cultivation usually does not apply chemical fertilizer as well as pesticide. Suggestions for improving cultivation are application of organic fertilizer or growth hormone (Fathonah & Sugiyarto, 2009), and implementation of proper plant spacing. Plant spacing should consider high productivity of purwaceng crop and high impact on reducing soil erosion.



Figure 5. Performance of purwaceng from different plant spacing

CONCLUSIONS

Purwaceng is a herb plant that has economic benefit, as well as soil conservation effect. In Keajar, this crop can be developed to support either agro-industry of herbal, as well as environmental benefit in the area of Dieng Plateau.

ACKNOWLEDGEMENT

This paper is written based on activity that still in progress under multi-years community services scheme funded by the Directorate Research and Community Services (DP2M DIKTI). The authors cordially thank to DP2M of DIKTI for funding the community services conducted in Keajar Wonosobo.

REFERENCES

- Darwati, I. dan I. Roostika., 2006. Status Penelitian Purwoceng (*Pimpinella alpina* Molk.) di Indonesia. *Buletin Plasma Nutfah*. Vol.12 No.1. Hal. 6-15.
- Rahardjo, M. 2003. Purwoceng tanaman obat aprodisiak yang langka. *Warta Penelitian dan Pengembangan Tanaman Industri* 9(2):4-7.
- Rivai, M.A., Rugayah, and E.A. Widjaja. 1992. *Thirty years of the eroded species medicinal crops*. Floribunda. Pioneer of Indonesian Plant Taxonomy, Bogor. 28 p.
- Rudiarto I. and Doppler W. 2013. Impact of land use change in accelerating soil erosion in Indonesian upland area: A case of Dieng Plateau, Central Java - Indonesia. *International Journal of AgriScience* Vol. 3(7): 558-576.

- Saputro, PB. 2012. *Tata Kelola Wisata Di Dataran Tinggi Dieng Provinsi Jawa Tengah*. Skripsi. Departemen Konservasi Sumberdaya Hutan dan Ekowisata. Fakultas Kehutanan. Institut Pertanian Bogor. v+63 hal. Unpublished
- Syahid SF, Rostiana O, Rohmah M. 2004. Pengaruh NAA dan IBA terhadap perakaran purwoceng (*Pimpinella alpina* Molk.) in vitro. *Indonesian Biopharmaca Exhibition and Conference*. Yogyakarta, 14-15 Juli 2004.
- Yuwana, DMS. 2010. *Analisis Permintaan Kunjungan Objek Wisata Kawasan Dataran Tinggi Dieng Kabupaten Banjarnegara*. Skripsi. Fakultas Ekonomi. Universitas Diponegoro. xvi+97. Unpublished.
- Hernani, RO. 2004. Analisis kimia akar purwoceng (*Pimpinella pruatjan*). *Seminar Indonesian Biopharmaca and Exhibition Conference*. Yogyakarta, 14-15 Juli 2004.
- Fathonah D, dan Sugiyarto. 2009. Pengaruh IAA dan GA terhadap pertumbuhan dan kandungan saponin purwaceng (*Pimpinella alpina*). *Nusantara Bioscience 1*: 17-22.

ISOLATION AND CHARACTERIZATION OF HUMIC ACID OF VARIOUS WASTE MATERIAL SON SALINE SOIL AND THEIR EFFECTS TO PADDY

Wanti Mindari, 2W. Guntoro, 3Zaenal Kusuma, 4Syekhfani

1,2 Fac. Of Agriculture UPN "Veteran" East Java, 3,4 Brawijaya Univ INDONESIA

Email : wanti.81263@gmail.com

ABSTRACT

Isolation and characterization of humic acid of various waste materials aimed to assess the its quantity and quality. The improvement potency of soil salinity and plant growth is needed to be studied further. Humic acids extracted from sewage plants, livestock and industry with 0.5 N NaOH (1:10) for 24 hours and precipitated approximately 12 hours to separate the humic and humin. Humic material containing humic acid and fulvic acid. Precipitation of humic acid with the addition of 5 N HCl to pH 2, then centrifuged at 200 rpm 30 minutes. Humic acid purification by washing with HF + HCl 1: 3 followed by water up to 3 times. Pure humic acid is dried at a temperature of about 40°C, and then characterized the value of E4/E6, C-organic, EC, pH and humic%. E4/E6 ratio values <5 shows the character of humic acid. Humic acid levels are best obtained from peat followed by coal, compost, filter cake, and manure. Cation exchange capacity in the range of 80-115 g me/100 humic acid at a pH between 6.7-7.5. EC humic acid 0 ms /cm. Humic acid potential in reducing salinity and the growth of rice for 35 DAP was not significantly different between the kinds of waste.

Keyword: C-organic, humid acid, pH, rice, waste matterial

INTRODUCTION

Humic acid is a derivative of the organic matter decomposes (Mikkelsen, 2005); <http://www.ihss.gatech.edu/sources.html>, Eladia, et al. 2005), main obtained in the manure, peat, lignite, coal, leonardite and in soil, water, waste, compost piles, marine and sediments lake. Humic acid is one of the humic substances (SH) which is soluble in alkali but not soluble in acid. A typical humic acid molecule may consist of a polymer structure of six carbon atoms in the aromatic ring of the base-or phenol trihidroksil connected by a bond-O-, -NH-, -N-, and -S-, and contains relationship-OH groups and quinone (-O-C₆H₄-O-). This structure contains a high density of functional groups of humic acid reactive molecules. AH molecular weight greater than AF. Stevenson (1982) in Spark (2003) noted that HS is considered as circular molecules, long chains or cross-linked macromolecular two or three-dimensional negatively charged mainly derived from ionization acid functional groups, eg, carboxyl.

Humic are produced from NaOH extraction in quantitative or qualitative aspects (Pansu,

2003). However, some procedure found from several studies indicating the methods of using NaOH to be reliable within certain limits and suitable for intended purpose (Tan et al., 1994). Isolation of humic acid by extracting dried sediment samples at alkaline conditions (a mixture of 0.1 M NaOH and 0.1 M Na₄P₂O₇ = 1: 1) and then the solution's fraction was added 6 M HCl until pH 2. The most basics of a extraction procedure are to mix a soil with a 0.1 M solution of NaOH at a ratio of soil: solution = 1:5, while the International Humic Substances Society (IHSS) using in 1:10 ratio. The general ratio that is used depends on the organic content of soils (Tan, 2003).

Process of extraction or separation of humic acid with the addition of alkaline NaOH , KOH to a pH of about 9 to form humic dispersed in water and lower the pH to about 2 to precipitate the humic acid. The separation of materials has been carried along by previous researchers. Geoff (2010) resulted in at least 70 percent humic acid through oxidation of the material under alkaline conditions at temperatures between 100 ° C and 200 ° C for at least 1-2 hours at pH 2.9 and precipitate under considerable pressure . Corresponding oxygen pressure in the process is 5-200 psi and alkali source corresponding to the hydroxyl include sodium, potassium, ammonium, lithium or that combination. fulvic acid extract by adding a base solution to humic substances so that the pH of the solution between 9-10. Extraction and fractionation of HA are various in period of about 4 hours to 7 days or from 12-24 hours. Tangible results in the AH isolation of soil is 9 hours (4 hours of extraction, 4 hours and 1 hour fractionation purification) (Nur Hanisah, et al 2008, Chen et al, (2009). Rosliza (2009) There is a linear relationship between the extraction time and the results of humic acid, but there is no relationship between fractionation and results of natural AH C, E4/E6, carboxyl, phenolic and total acidity AH .

Humic acid extraction with NaOH or KOH causes AH saturated with Na or K, so that the negative charge will attract positive charge. Negative charge (CEC) of humus is generally approved for H⁺ dissociation of functional groups, very dependent on pH. Carboxylate of several carboxyl group is quite sour to escape under pH 6 leaving a negative charge on the functional group: R-COOH = R-COO⁻+ H⁺ . as the pH system increases above 6. Other weaker and highly acidic carboxylic groups dissociated with phenolic OH and other weak acids at pH> 8. Dissociation of H⁺ from the acid groups throughout the pH range adds humus total negative charge. Dissociation of H⁺ from the phenolic OH, Amida (= NH), and other groups may also contribute to the negative charge. Protonated groups such as (R-OH₂)⁺ and (R-NH₃)⁺ can produce a positive charge, but overall the humus have negative charge . The charge's side (mainly COO⁻) allow SOM to retain cations can not be washed but the exchange form available to plants (Bohn et al 2001). CEC value of some materials can be used to predict the activity that correlated with humic acid. Humic acid content of various materials that are Leonardite/Humic, black peat, brown coal, Manure, Compost and Soil, respectively 40, 10, 10, 5, and 2%. Fulvic acid content of the same materials, respectively 85, 40, 30, 15, and 5% (<http://humintech.com/001/agriculture/information/general.html>). Chen et al. (1977) believed that the E4:E6 ratio was related to the degree of condensation of the aromatic humic components. Humic acid structure has e4/E6 ratio in between 3.3 - 5.0 (Pansu, 2003) while Orlov (1985) agree by showing a range of 4.1 - 4.8

Role of humic acid on the soil and plants

The use of humic materials in agricultural production continues to grow and evolve. There are a number of reports of both successful and unsuccessful use of this material, due to the wide

variety of materials and methods of manufacturing process (Mikkelsen 2005). Sometimes humic materials can provide a carbon (C) as a source of soil microorganisms, but the mechanism does not seem like, as humic material applications 5-20 gal / A will supply the 3-15 lb C / A if compared with > 4,000 lb C/A that is returned in the form of residues of corn. Humic acid indicates its function as a urease inhibitor and as a nitrification inhibitor in some conditions

Leonardite is beneficial in overhauling clay and compacting soils, assist in the transfer of micronutrients from the soil to the plant, ensuring water retention, accelerate seed germination, penetration, and stimulates the development of microflora populations in soils (Mikkelsen, 2005; Khaled and Fawy, 2011). Filter cake is the result of solid waste from the production process of making sugar. Humic acid (AH) of the filter cake has been beneficial to plant growth, including making lateral roots of maize (*Zea mays* L.) grown, associated with stimulation of plasma membrane ATPase activity. AH ability to support the development of roots showed that the HA filter cake can be used as a plant growth environment stimulator (Busato et al. 2010). Chen et al. (1977) believed that the E4:E6 ratio was related to the degree of condensation of the aromatic humic components. Humic acid structure has e4/E6 ratio in between 3.3 - 5.0. (Pansu, 2003) while Orlov (1985) agree by showing a range of 4.1 - 4.8

Humic substances play an important role in soil fertility and plant nutrition (Tan, 1998; Spark, 2003; Pettit 2011). Humic acid can neutralize soil acidity and alkalinity, improve and optimize the absorption of nutrients and water by plants, increase the buffering properties of soil, acting as a natural chelator for metal ions under alkaline conditions and promote absorption by the roots, has very high cation exchange capacity, promote the conversion of nutrients (N, P, K, Fe, Zn and other elements) into a form available to plants, improving nitrogen uptake by plants, reducing the reaction of phosphorus with Ca, Fe, Mg and Al and released into a form that is available and beneficial to plants (Khaled and Fawy., 2011). Doses of humic substances application is 0, 2 and 4 g.kg⁻¹ to the saline soil one month before planting and humic acid liquid 0, 0.1 and 0.2% in the leaves sprayed twice on days 20 and 40 after emergence of seedlings increase the absorption of nutrients (Khaled and Fawy, 2011).

MATERIAL AND METHODS

A. Site Study and Treatment

Laboratories experiments were conducted at the Faculty of Agriculture UPN "Veteran Jawa Timur on June to September 2012. Humic acids extracted from sewage plants, livestock and industry with 0.5 N NaOH (1:10) for 24 hours and precipitated approximately 12 hours to separate the humic and humin. Compost of sewage plant, manure, filtercake, coal, and peat were sieved to pass a 2-mm sieve, as supposed by Tan (2003). Each of them weighted 50 g entered in to plastic bottle of 1L. and added 500 ml NaOH 0.5 N into bottle (1:10), and then sailed and positioned in shaker. Agitation of this solution were done for 24 hours. After that, the extract (Humic material) displaced from depletion (humin), containing humic acid (gel, brown -black) and fulvic acid (solution, orange). Precipitated of humic acid with the addition of 5 N HCl to pH 2, then centrifuged at 2000 rpm 30 minutes. Humic acid (HA) purification by washing with HF + HCl 1: 3 followed by water up to 3 times. Pure humic acid was dried at a temperature of about 40°C and then characterized the value of E4/E6, C-organic, EC, pH and humic%. E4/E6 ratio values <5 shows the character of humic acid.

Saline Soil samples were taken from Gunuganyar at a depth of 0-20 cm, dried and sieved with a 2 mm sieve. The principle of this soil were pH 7.8, EC 1.5 mS/cm, C-organic 0.8 %, CEC 45 me/ 100g, Exchangeable Ca, Mg, Na, and K were 18, 3, 2, 1 me/100g respectively.

B. Experimental Design

A pot experiment was arranged in a Completely Randomized Factorial Design. It was conducted at Faculty of Agriculture, University of Pembangunan Nasional "Veteran" East Java. The first factor comprises 5 kind organic matter: compost, manure, guano, while the second factor comprises six levels acid humic powder of 0, 0,5, 1,0, 1,5, 2,0, and 2,5 g/kg respectively. Each treatment combination was repeated 3 times.

Soil were weighed 3 kg equivalent to absolute dry weight, mixed with humic acid and than incubated at a field capacity in room condition for 2 weeks. After incubation, the basic NPK fertilizers equivalent to 200 kg ha⁻¹ was added ($3 \times 100 \text{ mg} = 300 \text{ mg pot}^{-1}$). Rice seedlings planted to sink. It taken from a nursery at 15 cm height. Two seedlings of rice were planted per pot and then a light irrigation ($EC_w < 1$) was applied up to saturate. After 2-weeks planting, the plants were thinned to 1 plant per pot and its growth was maintained until harvest. Water was added until the soil is saturated with $EC < 1 \text{ mS.cm}^{-1}$. Plants were maintained in a screen house with the temperatures ranged of 27-30 °C. Pest control was carried out if a pest attack symptom was found and a preventive action was performed by a mechanical handling.

C. Sampling and assessment

Humic acid pH made about pH 6 from pH 2 by adding a few drops of KOH. EC of HA measured in a powder or liquid form. The value of C-organic measured in Walkey and Black method as proposed by Marc Pansudan Jacques Gautheyrou (2003). Organic matter was weighed 0.1 g incorporated into the Erlenmeyer flask and added 10 ml of 1N potassium dichromate and 20 ml of concentrated sulfuric acid, allowed to stand 30 minutes Extractant was added with 200 ml of water, 10 ml of concentrated phosphorus acid, 0.2 g of sodium fluoride and 10 drops of diphenyl amine. Excess dichromate titrated with ferrosulfat 1 N. Percent of HA was measured gravimetrically at a temperature of about 100°C. The value of E4 and E6 HA (1 ml HA liquid : 10 ml 0,05 N NaHCO₃) were measured in 465 and 665 nm Spectro Pharo 100 respectively. E4/E6 ratio values was obtained by dividing the value of E4 with E6. CEC of HA was measured with NH₄OAc pH 7 1N extract. Soil chemistry characteristic (pH, EC, C-organic) were measured from a depth of soil sub sample (0-10 cm), 30 DAT (days after treatment) of HA with the same method as before. Growth of rice were evaluated for hay and roots dry weight, plant length, and the number of rice tillers in 35 days after planting (DAP).

D. Statistical analysis

The data of HA characteristic was corrected to kinds of sewage plant, livestock, and industry. The value of characteristic of HA was correlated with the growth parameters, and soil chemical characteristics. The resulting value is correlated with the growth parameters. Data were analyzed by analysis of variance (ANOVA) using Microsoft excel. Means of value were tested by Least Significance Different (LS D) at $P = 0.05$ to determine the soil salinity and

rice growth from effect of level and kinds of humic acid.

RESULTS AND DISCUSION

Characteristic of Humic acids that were extracted from sewage plants, livestock and industry with 0.5 N NaOH (1:10) for 24 hours, precipitated from fulvic acid with the addition of 5 N HCl to pH 2, purification by washing with HF + HCl 1: 3 followed by water up to 3 times, dried at a temperature of about 40oC, is presented in Table 1.

Tabel 1. The value of C-organic, E4/E6, EC, and CEC humic acid

No.	Source	Origin	C-org		HA %	E4/E6	EC mS/cm	CEC Me/100g
			liquid (%)	powder				
1	coal	Kota waringinhilir, Kalimantan	23,07	29.27	4,6.00	2,37	0,00	104,09
2	peat	---“---	46.32	44.96	7,60	2,92	0,00	116,83
3	Compost	GunungAnyar	8.59	16.39	2,60	3,71	0,01	80,72
4	Manure	GunungAnyar	4.21	9.81	1.80	4,40	0,01	59,48
5	Guano	Gresik	15.28	18.07	1.20	4,74	0,03	47,48
6	hay	Gununganyar	5.84	7.72	1.80	4,35	0,01	79,48
7	Filter cake	Sidoarjo	5.34	7.62	1,60	4,58	0,02	69,48

Highest Humic acid levels are obtained from peat followed by coal, compost, filter cake, and manure. Cation exchange capacity in the range of 80-115 g me/100 humic acid at a pH between 6.7-7.5. EC humic acid 0 ms /cm. Peat contains the highest of a C-organic, humic acid, and CEC than other organic materials, respectively by 7.6%, 44, 96%, 116 me/100g followed by coal, compost, rice straw, manure, filter cake, and guano. C-organic content of powder HA is higher than the liquid HA. All of humic acid has a low EC value in the range of 0 to 0.03 mS/cm. C-organic content of organic matter was positively correlated with % humic acid and CEC, but negatively correlated with E4/E6 values. Humic acid was potentially reducing salinity and the growth of rice for 35 DAP. It was not significantly different between the kinds of waste

Table 2. Correlation between humic acid character

	C-org-powder	C-org-liquid	% HA	E4/E6	EC	CEC
C-org-powder	1,00	0,99	0,94	-0,70	-0,57	0,73
C-org-liquid		1,00	0,93	-0,70	-0,40	0,71
% HA			1,00	-0,94	-0,64	0,85
E4/E6				1,00	0,80	-0,78
EC					1,00	-0,69
CEC						1,00

The E4/E6 ratio values of <5 shows the character of humic acid, while value of > 5, is fulvic acid (Tan, 2003). The E4/E6 ratio of humic acid from kinds of these material were < 5, (2, 9- 4,74). This is slightly different from the expressed by Tan (2003), who obtain E4/E6 ratio of humic acid extracted from the ground, which is around 4-5. The higher content of organic material will be high humic acid content, which is characterized by the ratio of the value. The different yield of HA was caused by different extraction and kinds of organic matter that use.

I used of NaOH 0.5N, while others used of NaOH 0.1N, and mixture of NaOH and Na₂PO₄O₇ 1 N, or by water. Sodium hydroxide solution is believed as the best extractor than others. The increasing of dose of humic acid did not decrease pH EC yet, but increased number of tiller and hay weight of rice. Purification of humic acid lowering soluble Na content of 25-45%

Humic acid extraction with NaOH causes AH saturated with Na, so that the negative charge will attract positive charge. Surface area and adsorption capacity per unit mass of humus is larger than the layer silicate minerals. Cation Exchange Capacity (CEC) of humus is generally approved for H⁺ dissociation of functional groups. All humus loads are very dependent on pH, with humic acid and fulvic acid behaves as a weak polyelectrolyte. Separation of carboxyl and phenol may produce 85 to 90% of the negative charge of humus. Carboxylate of several carboxyl group is quite source to escape under pH 6 leaving a negative charge on the functional group: R-COOH = R-COO⁻ + H⁺. As the pH of the system increases above 6, unit R-COOH separates on various different pH. The charge's side (mainly COO⁻) allow soil organic matter (SOM) to retain cations can not be washed but the exchange form available to plants (Bohn et al 2001). Application doses of humic acid from a variety of sources up to 2,5 g/kg to saline soil for 30 days after that were not significantly different on soil pH, Ec and C-organic, and the length of the plant, but significantly different on straw weight and number of tillers (Table 4). Although soil salinity indicators (pH and EC) did not affect the application for 30 days, but the number of tillers and straw weight significantly, and the best results on the application of humic acid for about 1,5-2,0 g/kg

Tabel 4. Anova of soil characteristic and plant growth parameter caused humic acid application.

SK	db	F- calculate					F table		
		EC	pH	C-org	Weight of hay	Number of tiller	Lenght	5%	1%
Blok	2	0,014 ns	0,014 ns	0,002 ns	3,04 ns	141,66 **	1,10 ns	4,30	9,92
treatment	17	0,14 ns	0,015 ns	0,104 ns	8,36 **	5,87 **	1,04 ns	2,11	2,90
HA	2	0,16 ns	0,039 ns	0,616 ns	11,61 **	7,03 **	1,90 ns	4,30	9,92
DOSE	5	0,33 ns	0,022 ns	0,018 ns	14,60 **	9,46 **	0,70 ns	2,57	4,03
AH x DOSE	10	0,05 ns	0,007 ns	0,045 ns	4,59 **	3,85 **	1,04 ns	2,23	3,17
Galat	34								
Total	53								

Numbers accompanied by the same letter no significantly different at p = 0.05

Yield experiment above is almost similar with reseach that was doing by Khaled and Fawy (2011), Turan, 2011; Asik, 2011, they find that application dosis of humus 0, 2, 4 g/kg at one month before planting, increased the N of corn uptake. while Barışet al and ÇELİK et al (2010) find that dose of humus 0,1, 2 g /soil kg increase N uptake of wheat and decrease soil salinity from concentration of NaCl of 60 mM or CaCO₃ 40 %. Paksoy, et al. (2010) and Çimrin, et al (2010) find that dose of AH 0- 1500 mg/kg and K 0- 300 mg/kg or in P 0- 150 mg/kg) at salin soil respectively. they can increased N, P, K, Ca, Cu, Fe, Mn or Cu conten and plant growth in p < 0.005. Optimum yield was gained with dose of 69 mg kg⁻¹ P with HA 750 mg kg⁻¹. Value of Na content at shoot and root decreased with the increasing of doses

Table 5. Mean of plant growth parameter caused humic acid application

Treatment	C-Organic	Hay weight	Lenght plant	Number of tillering
AH-Guano	0,90 a	51,23 a	62,78 a	18,35 b
AH-manure	0,85 a	54,14 b	64,81 a	16,87 a
AH-compost	0,73 a	64,66 c	63,97 a	22,61 c
BNT 5 % =	0,15 a	0,47	0,50	0,77

Numbers accompanied by the same letter no significantly different at $p = 0.05$

Treatment	C-Organic	Hay weight	Lenght plant	Number of tillering
0	2,52 a	36,37 a	63,83 a	10,00 a
0,5 g	2,47 a	60,88 d	64,44 a	19,59 b
1,0 g	2,58 a	58,38 c	64,89 b	20,70 b
1,5 g	2,36 a	52,63 b	64,11 a	24,30 c
2,0 g	2,32 a	67,94 f	63,44 a	19,33 b
2,5 g	2,62 a	63,86 e	62,39 a	21,74 b
BNT 5%	2,59 a	0,94	1,01	1,53

of humic. Gulser et al (2010) find that the higher doses of HA 0, - 4 g/kg and calcium nitrate (0 -150mg kg⁻¹) at saline soil (+ 60 mMNaCl) affect germination signficantly. Optimum Doses of HA are 1000 and 2000 mg kg⁻¹ and 50 mg kg⁻¹ CaNO₃ increasing dry weight and fresh leaf, diameter of root and shoot , root lenght and tips. The highest doses of AH (4000 mg kg⁻¹) and CaNO₃ (100 and 150 mg kg⁻¹) decreasing those criteria in salin condition.

CONCLUSION

The value of Humid acid various organic matters, was depended on environmental processes, extraction tecnique, purification and acids solution. Purification is very important proceses for extraction, especially if it used Na in extracxtion, for safety application to soil and plan. Humic acid contain on peat and coal were highest than other matterial. Doses of HA appllication of 2.5 g/kg was not significantly decreaseing soil pH, EC and C-organic matter from Gunungnyar village, but it was increasing plant growth parameter, except plant lenght.

ACKNOWLEDGMENTS

We thank the farmers for the soil sampling as well as to provide information on land management, Directorate of Higher Education, Ministry of Education and Culture of Indonesia and the staff of the Department of Soil Science, Brawijaya University that contributed in the soil analysis , and Special thanks for Dr.Ir. Abdul Mukri Prabowo, M.Agr.Sc deceased.

REFERENCES

- Bohn, H. B.L.McNeal, and G.A. O,connor, 2001. Soil Chemistry, Third Edition. John Wiley & Sons.Inc. 307p. (ionpenting 26-67).
- Bariş B. Aşık, Murat A. Turan, Hakan Çelik, Ali V. Katkat, effect of Humic Substances on uptake of wheat (Tritium durum)

- Busato J.G.; D.B. Zandonadi; L.B. Dobbss; A. R.Façanha; L.P.Canellas. 2010. Humic Substances Isolated From Residues Of Sugar Cane Industry as Root Growth Promoter. *Sci. Agric.* 67, (2), p.:206-212,
- Ching, P.C. and S.A. Barber. 1979. Evaluation of temperature effects on K uptake by corn. *Agron. J.* 71:1040- 1044.
- Chen CHH, OH.Ahmed,Nik M.Ab. Majid and M. B.Jalloh. Reduction of Isolation Period of Coal Humic Acids .*American Journal of Applied Sciences* 6 (7): 1327-1330, 2009
- Çimrin, K. M. Ö.Türkmen, M.Turan and B.Tuncer. 2010. Effect Of Humic Acids andPhosphorus on Growth and Nutrient Content of Pepper SeedlingsGrown Under Mode-rate Salt Stress In Growth Chamber Conditions. *fric.J.Of Biotech.* 9(36) : 5845-5851,
- Çelik H. Ali V. Katkat, B B. Aşık, MA. Turan 2010.Effect of humus on growth and nutrient uptake of maize under saline and calcareous conditions. *Agriculture* 97 (4), : 15-22,
- Eladia M. P.Méndez, J. Havel, 2005. Humic substances.compounds of still unknown structure: applications in agriculture, industry, environment, and biomedicine Jiří Patočka3 *J. Appl. Biomed.* 3: 13.24.
- Fortun, A. C. Fortun, C. Ortega. 1989. Effect Of Farmyard Manure And Its Humic Fractions On The Aggregate Stability Of A Sandy–Loam Soil. *JSS* 40, (2,): 293–298.
- Foth, H.D. and B.G. Ellis. 1997. *Soil Fertility*. CRC Press, Boca Raton, Florida.290 p.
- Freire j.M.G.M., R. A. Ekisoain, A.M.Z. Arregui, E.B. Lluundain, M.F.Ramirez. 2010. Heteromolecular metal – Humat (chelate) complexes. Patent No.: US 7,947,818 B2
- Geoff M S.J. del Mc. 2010 Extraction of fulvic mineral from humic substances. Patent No: US 7,825,266, B1
- Goff D.W..1982. Method Of Producing Humic Acid. US Patent 4,319,041
- Havlin, J.L., J.D. Beaton, S.L. Tisdale, and W.L. Nelson. 1999. *Soil Fertility and Fertilizers*. 6thEdition. Prentice Hall. Upper Saddle River, NJ. 499 p.
- Khaled, H. and H.A. Fawy. 2011. Effect Of Different Levels Of Humic Acids On The Nutrient Content, Plant Growth, and Soil Properties Under Conditions Of Salinity . *Soil & Water Res.*, 6(1): 21–29
- Lori Jr. L. Busbar et al. Production Of Acid Soluble Humates 5,663,425.
- Lutan , R. Y . 1999. Karakterisasiasamhumatdarisedimenhutanlindungbakau (mangrove) MuaraAngkeTeluk Jakarta. FMIPA-UI.Abstrak.
- Mikkelsen, R.L. 2005.Humic Materials for Agriculture. *Better Crops* 89 (3): 6-10.
- Moberly P. K. and J . H. Meyer .1978. Filter Cake - A Field And Glasshouse Evaluation South African Sugar Association Experiment Station, Mount Edgcombe. *Proceedings Of The South African Sugar Technologists' Association*
- Murat A. Turan , Barış B. Aşık, Ali V. Katkat, Hakan Çelik. The Effects of Soil-Applied Humic Substances to the Dry Weight and Mineral Nutrient Uptake of Maize Plants under Soil-Salinity Conditions

- Paksoy, M.,Ö. Türkmen and A.Dursun. 2010. Effects of potassium and humic acid on emergence, growth and nutrient contents of okra (*Abelmoschusesculentus*L.) seedling under saline soil conditions. *Afric.Jour. of Biotechnology* Vol. 9(33), pp. 5343-5346,
- NurHanisah M. R.,O.H. Ahmed, K.Susilawati,N. M. Ab. Majid andM. B.Jalloh. 2008. Determination of Minimal Duration Essential for Isolation of Humic AcidsFrom Soils in Forest Restoration Programmes *American Journal of Agricultural and Biological Sciences* 3 (3): 597-601, 2008.
- Pettit R.E.. *Organic Matter, Humus, Humate, Humic Acid, Fulvic Acid, And Humin: [Http://Www.Calciumproducts.Com/Articles/Dr. Pettit_Humate.Pdf](http://www.Calciumproducts.Com/Articles/Dr._Pettit_Humate.Pdf)*
- Rosliza S, O.H. Ahmed, K. Susilawati,N.M. Ab. Majid and M. B. J. Simple 2009. Rapid Method of Isolating Humic Acids fromTropical Peat Soils (Sapristis) . *American Journal of Applied Sciences* 6 (5): 820-823, 2009.
- Spark, 2003. *Environmental Soil Chemistry*, Academic Press. 345 p
- Stuart E. Lebo, Jr., Schoield; KevinR. Wirtz, Mosinee; Stephen L, Dickman, Wausau, 1997. *Production Of Oxidized Humic Acids By An Oxygen-Alkali Process*5,688,999
- Tan, K.H. 1998. *Principles of soil chemistry*.3rd ed. 521p.
- Tan. K. H. 2003. *Humic Matter in Soil and the Environment.Principles and Controversies.University of Georgia.Athens, Georgia, U.S.A.*
- Theng, B.K.G. 2012. *Humic Substances. Developments in Clay Science*, vol. 4,: 391–456
- Tenzer, A. I. L. Fla. 1987. *Bioattvating System For Increased Plant Growth And Yields. Patent Number:4,666,497*

LCA METHODS ON THE TREATMENT OF BIOMASS RESIDUES IN A PALM-OIL SYSTEM

Edi Iswanto Wiloso,^{1,2*} Reinout Heijungs²

¹Research Center for Chemistry, Indonesian Institute of Sciences (LIPI),
Puspiptek, Serpong, Tangerang, Indonesia

²Institute of Environmental Sciences (CML), Leiden University, P.O. Box 9518, 2300 RA,
Leiden, The Netherlands

*Corresponding author: ediiswanto@yahoo.com; wiloso@cml.leidenuniv.nl

ABSTRACT

Palm oil mills generate large amounts of biomass residues, such as empty fruit bunches (EFB). According to best agricultural practices, these biomass residues are supposed to be returned back to plantation as mulch to maintain soil fertility. This closed-loop nutrient cycle can reduce the need for external fertilizers resulting in an efficient palm oil system. However, there are variations in practice. Some of the EFB may be sold as co-products for various uses, further processed into bioenergy, or simply dumped or burned without energy recovery. These later options are more likely to occur in oil mills with limited or no plantation areas, processing FFB from other plantations. In different situations, the status of EFB could be a waste or commodity with prices. The difference in economic status of and treatment options for biomass residues can cause variations on the way to perform life cycle assessment (LCA), leading to divergence in results and complicated interpretation. In this regard, comparison among LCA results, developed in consistent manners, is needed to be able to properly choose which treatment options would be the most sustainable one. This paper aims at illustrating the ways to handle diverse scenarios on the treatment of biomass residues in a palm oil system, focusing on the system boundary definition and the choices of allocation methods, while making all the methodological steps as transparent as possible. Various treatment options and valuation schemes for EFB were chosen to cover possible system boundary with reference to the palm oil system: internal and external recycles, internal waste treatment, and external uses. Life cycle inventory (LCI) of these model scenarios were developed based on Ecoinvent v2.2 databases. Allocation methods are suggested and their effects on the sustainability of palm oil products were discussed.

Keywords: *Life cycle assessment, Allocation methods, Global warming impact, Palm oil, Empty fruit bunches.*

INTRODUCTION

A. Palm Oil in Indonesia

Elaeis guineensis is a tropical forest palm native to West and Central Africa. Grown in plantations, it produces 3–8 times more oil for a given area than any other tropical or temperate oil crops (soybean, sunflower seed, canola or rapeseed oil) (Sheil *et al.*, 2009). The areal coverage of oil palm plantation in Indonesia in 2009 was 7.5 million hectares with crude palm oil (CPO) production of 20.5 million ton (MOA, 2010), 15.5 million ton of which was exported as CPO or its derivatives (Hasan, 2010). In general, oil palm is highly productive business and commercially profitable at large scales because palm oil demand is generally rising (Sheil *et al.*, 2009). Large plantation are dominated by private companies up to around 49.47%, smallholders accounted for 41.80%, and the state companies owned the remaining 8.73% (ICN, 2010). Major export destinations of CPO and its derivatives are India, China, and Europe (Hasan, 2010a). Recent implementation of the new European Union Directive on GHG emission on palm oil products imposes a stricter requirement on some of the sustainability criteria to enter the European market (ICN, 2010).

Current planting techniques and materials are supposed to achieve productivity of 32 ton of fresh fruit bunches (FFB) per hectare per year, yielding 6–7 ton of CPO. But in reality, typical yields of smallholders are 2.5 ton CPO/ha.year, while large-scale producers are between 4 and 6 ton CPO/ha.year. Reasons for this disparity probably include no sufficient access to good planting stock, fertilizer, and low intensity maintenance (Sheil *et al.*, 2009). Some key sustainability issues in the palm oil plantation and palm oil processing are noted by the World Bank. These are wide productivity gap among small and large scale plantation, land and social conflict, deforestation, biodiversity loss, and climate change (Hasan, 2010b). Some improvements need to be done to support sustainable palm oil management. In that relation, Indonesian palm oil industry is now in the process of transforming into a more sustainable practice by adopting RSPO (Roundtable Sustainable on Palm Oil) and ISPO (Indonesian Sustainable Palm Oil). RSPO is voluntary business to business arrangement, while ISPO is mandatory on national level starting in 2012.

B. Potential of Biomass Residues and Treatment Options

Biomass residues generated from plantation areas are palm fronds from periodic harvesting of FFB, and palm trunks from re-planting activities. The common management practice for this biomass is to place them on the fields as mulch (land covering, soil conditioner, and fertilizer). In Malaysia, one ton of harvested FFB will result in 7 ton of trunks and 26.2 ton of fronds (Yunus *et al.*, 2010). Another source of biomass residues is palm oil mills. Palm oil is extracted from the pulp of the fruit, leaving large portion of biomass residues. The estimated biomass residues in 2009 included empty fruit bunch (EFB) of 16,657,809 tons, mesocarp fiber (MF) of 11,422,497 tons, and palm kernel shell (PKS) of 5,092,530 tons (Hambali *et al.*, 2010). In Indonesia, there were about 608 oil mills with total processing capacity of 34,280 ton FFB/hour in 2008.

Press fiber and shell generated by the palm oil mills are largely used as solid fuels for steam boilers to generate electricity. These biomass residues are typically used to meet the internal energy demand for the operation of a palm oil mill. According to best agricultural practices, EFB are supposed to be returned back to plantation as mulch to maintain soil fertility. This closed-loop nutrient cycle can reduce the need for external fertilizers resulting in an efficient palm oil system. The properties of EFB which are wet, bulky, and voluminous are unfavorable for handling and transportation. The distance between oil mills and plantation may become the limiting factor for the feasibility of land application. Consequently, there are variations in practice. Some of the EFB may be sold as co-products, further processed into bioenergy, simply dumped, or burned without energy recovery. These later options are more likely to occur in oil mills, with limited or no plantation areas, processing fresh fruit bunches (FFB) from other plantations. In recent years, there is also a growing interest to convert this lignocellulosic biomass into bioenergy (Lim & Lee, 2011; Wiloso *et al*, 2012; Chiew & Shimada, 2013).

C. Previous LCA Studies on EFB

An integrated system producing more than one product, such as palm oil or biodiesel together with compost, bioethanol, biochar, biooil, or syngas is known as a multi-product system. The environmental impact in such situation can be solved by either a partitioning approach, or system expansion in which the system boundary is extended to accommodate more than one functional flow. Previous LCA studies on a palm-oil system involving further treatment on EFB have typically used substitution or avoided burden/process approaches (see Table 1). This is done by giving to the final results environmental credit (saving) if the residues are valued as goods, or environmental debit (emissions) if they are valued as wastes.

Table 1: LCA studies on palm-oil systems involving further treatment on EFB.

Parameters	Stichnothe & Schuchardt (2010)	Lim & Lee (2011)	Hansen <i>et al</i> (2012)
Product systems	Palm oil	Biodiesel	Biodiesel
Valuation on EFB	Goods and wastes	Goods	Goods and wastes
Proposed treatment on EFB	Compost	Bioethanol	Biochar, biooil, syngas
Goals	To evaluate environmental impacts of treating EFB and POME	To maximize the output from a limited amount of land	To compare the GHG balance of different treatments for EFB
Functional units	1 ton of FFB	1 hectare of land in 100 years	1 ton biodiesel
Allocation methods	Substitution	Substitution	Substitution
Impact category	Energy, GHG, and 8 others	Energy, GHG	GHG

Recently, Chiew & Shimada (2013) discussed the environmental performance of the conversion of EFB into various products, including ethanol, methane, briquette, heat and power (CHP), compost, medium density fiberboard (MDF), pulp and paper. In contrast to the studies listed in Table 1, these alternative processes were evaluated independently, not related to the main palm oil system. These literature studies on the treatment of EFB illustrate wide variety in terms of goal and scope, system boundary, functional units, and impact categories. Therefore, comparison and interpretation among results need to be done very carefully since each LCA studies were carried out quite diverse methodological choices.

D. Valuation on Biomass Residues

Input or output within a product system in LCA can be categorized in terms of products, co-products, and wastes. Economic flows by definition travel between two unit processes, so each economic flow must be the output of one process or the input of another process. Co-products are a generic term to include all potential outputs besides the main product. Adopting this view, a palm oil system, for example, has to consider also all biomass residues generated in the plantation and oil mills. Therefore, ideally, trunks and fronds in the plantation, EFB, shells, and fibers in the oil mill are supposed to be included in the LCIs. But, then, we also have to differentiate between co-products from wastes.

To distinguish products from wastes, the economic value of flows can be used as the determining factor. The common criteria are that co-products have certain values comparable to the main product, while wastes have no or even negative value (Singh *et al*, 2010). Guinée *et al* (2009) define a product as a flow between two processes with a positive economic value, whereas a waste as a flow between two processes with a negative economic value. The process following a waste flow can be either a treatment unit to reduce the pollution strength of the waste or a conversion unit to make another product (recycling). In this paper, we contrasted EFB as wastes or as goods. Goods in the LCA terminology are one form of products among other forms (materials, energy, and services) (Guinée *et al*, 2009).

A waste stream is conventionally assumed to be free of environmental burden, since the impact has been charged mostly to the products and co-products. Further distinction is, however, required between goods and wastes. There are quite a few cases where we do not know for certain if the price of an agricultural residue is positive or negative, such as the case of EFB that remains within one company. The presently co-products that do not have yet a real market value, in the future may become valuable. Further, due to technological developments, fluctuations in markets, and governmental intervention, goods may rapidly turn into a waste or the other way around (Heijungs & Wiloso, 2012).

The interest to convert biomass residues in a palm oil system into valuable products now becomes a trend (Stichnothe & Schuchardt, 2010; Lim & Lee, 2011; Hansen *et al*, 2012; Chiew & Shimada, 2013). Biomass residues dumped on fields un-utilized or burned without energy recovery are considered as wastes with no or negative economic values. It means that actors in the chain have to pay for the treatment or for getting rid of the waste stream. Depletion of natural resources has encouraged the practice of recycling of wastes or residues for useful products. This treatment option is even more

advantageous if the residues potentially generate harmful emissions if not properly treated. These developments strongly affect valuation of biomass residues in a palm oil system.

The following are some development on the interest of using oil palm biomass residues for energy purposes. In Malaysia, the Small Renewable Energy Power Program (SREP) was launched in 2001 to encourage utilization of agriculture wastes for electricity generation to be connected to the national grid. This policy has attracted investments to develop CHP plants using palm oil biomass residues, including EFB. Some of them are installed at the palm oil mill and some are independent power plants connected to the grid with power plant scales ranging from 1 to 14 MW. So far, there were 3 CHP plants are reported in operation under the SREP program (Chiew & Shimada, 2013). In Indonesia, the government recently issued ministry of energy and mineral resources regulation (no. 4, 2012 and no. 19, 2013) regarding electricity price (feed-in tariff) from bioenergy-based power plants. Within the period of 2001 to 2012, there were 10 on-grid power plants based on palm oil wastes with contracted capacity between 2 to 10 MW. However, not all of these facilities are continuously in operation. The main issues are the increasing price and continuity of feedstock supply (Kusdiana, 2013). These developments will surely affect the way we value EFB in the coming future, and therefore assessing this biomass residues at different valuation schemes become important.

E. System Boundary and Allocation Methods

A multi-functional system consists of unit processes, yielding more than one functional flow including co-production, combined waste processing, and recycling (Guinée *et al*, 2004). Co-production is a multi-functional system having more than one functional outflow and no functional inflow. Recycling is a multi-functional system having one or more functional outflows and one or more functional inflows. Combined waste processing is a multi-functional system having no functional outflow, but more than one functional inflow. Relevant multi-functional systems involving the use of biomass residues in an agricultural system are illustrated in Figure 1 (based on Wiloso & Heijungs, 2013). The consequences of such multifunctional systems ([a] and [b]) are that the environmental burden of the process has to be split according to a partition procedure. In the case of [a] with two output products, the environmental burden is partitioned between Product1 and Product2. In the case of [b] with waste input and product output, the environmental burden is to be partitioned between upstream and downstream links. In the case of [c], there is no allocation problem, therefore, all environmental burdens are charged to the waste input.

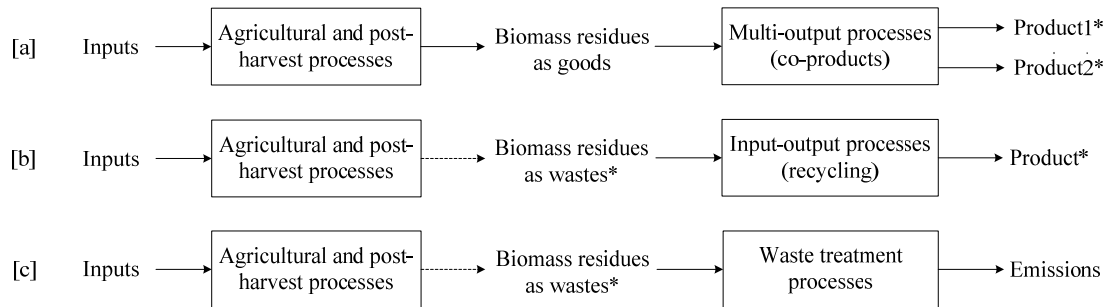

Fig. 1: Status of biomass residues and possible treatment options in an agricultural system. The cases [a] and [b] result in multi-functional flows, while the case [c] does not yield products, but emissions. (---> = upstream chain of the waste streams is disregarded; * = functional flows)

The environmental load of multi-functional systems can be allocated in several ways. Guinée (2002) distinguishes two steps in solving the multi-functionality problem. The first concerns avoiding burden allocation in accordance with the ISO preference. This is done by reducing the system boundary of a multi-functional system to a unit operation level, or by expanding the boundary of the analyzed product system to include additional functions related to the co-products or recycled wastes. The resulted expanded system includes more than one functional unit.

The term system expansion is often confused with the substitution method. Both are multi-functional systems, but manifested in quite different ways. In this paper, the system expansion is done by introducing an additional unit process (treatment of biomass residues) within the system boundary a palm oil system. Therefore, the additional unit process becomes an integral part of the main system, and the LCI is solved simultaneously. In substitution approach, the system keeps the single functional input or output, but correcting the system by subtracting an avoided, hypothetical process (Voet *et al*, 2008; Guinée *et al*, 2009). The substitution approach is done by subtracting the avoided impact using equivalent process available in literatures. Therefore, the LCI of the main system and the additional process are solved separately.

The second step concerns solving the remaining multi-functionality problems by allocation on the basis of physical properties or economic values. The physical allocation can be based on the relative mass, carbon content, or energy content of the outputs, while economic allocation can be based on the relative market value of the outputs. In this paper, the partitioning approach splits environmental burden between co-products if the residues valued as goods, or between upstream and downstream links of the unit process if the residues valued as wastes are converted into final products. Further discussion on the procedure to deal with allocation procedures and system expansion can be found in Tillman *et al* (1994) and Heijungs & Guinée (2007).

The difference in economic status of the EFB, in terms of goods or wastes, and the different treatment options for biomass residues can cause variations on the way to perform life cycle assessment (LCA), leading to divergence in results and complicated interpretation. Comparison among LCA results developed in consistent ways is needed to choose which options would be the most sustainable one. This paper aims at

illustrating the ways to handle diverse scenarios on the treatment of biomass residues, focusing on the system boundary definition and the choices of allocation methods, while making all the methodological steps as transparent as possible.

METHODS

The models were developed to represent a palm-oil system integrated with various possible options in treating biomass residues (conversion of wastes to products, conversion of goods to products, treated in a waste treatment unit, sold as co-products to external parties). In reference to the main palm oil system, the boundary of the models can be classified into internal recycle, external recycle systems, internal waste treatment, and external uses. The inventory data were based on Ecoinvent v2.2 (2010) and software used to develop the LCA models was CMLCA v5.2 (2012). LCI data of Ecoinvent used in this paper were oil palm plantation (ID#199), palm oil mills (ID#150), mulching (ID#171), production of ethanol from soft wood chips by fermentation and distillation (ID#456, ID#11795), and burning in a municipal solid waste incinerator for wood (D#2130).

Figures 2 and 3 illustrate six possible scenarios on the treatment of EFB. In Scenario 1 and 2 (Figures 2a and 3a), EFB is returned back to the fields as mulch. Significant burden is expected from transportation of EFB from the oil mills to the plantation fields. This scenario is applied for both young trees in re-planting areas, and productive trees to supplement inorganic fertilizer. This internal recycle cases are typically not modeled in the LCI, for example in the case of Ecoinvent v2.2. Here, the EFB did not appear in the modeling of palm oil systems. The fact that Ecoinvent did not include EFB in the LCI shows that biomass residues are actually almost never treated as actual co-products of an agricultural system. In this paper, we modeled this internal recycle case, consisting mostly transportation of the EFB from the oil mills to the plantation. The LCI, however, did not include the GHG emissions to the air and fertilizing value of EFB on soil quality.

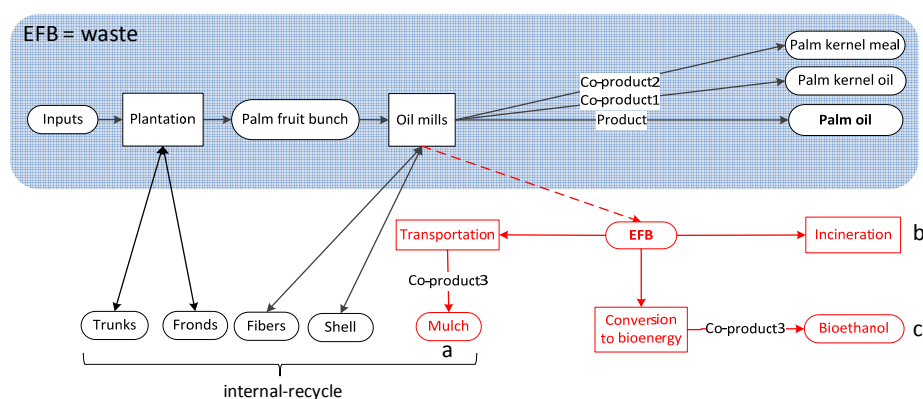

Fig. 2: System boundary of possible treatment options for EFB when valued as wastes: [a] returned back to the plantation as mulch, [b] treated in waste treatment units, and [c] converted to bioenergy. Dashed lines mean that upstream chain of the waste stream is disregarded. (○ = goods or wastes; □ = unit process; ↔ = internal recycle in the plantation or oil mills; in red = EFB sub-systems; shaded = main palm oil systems)

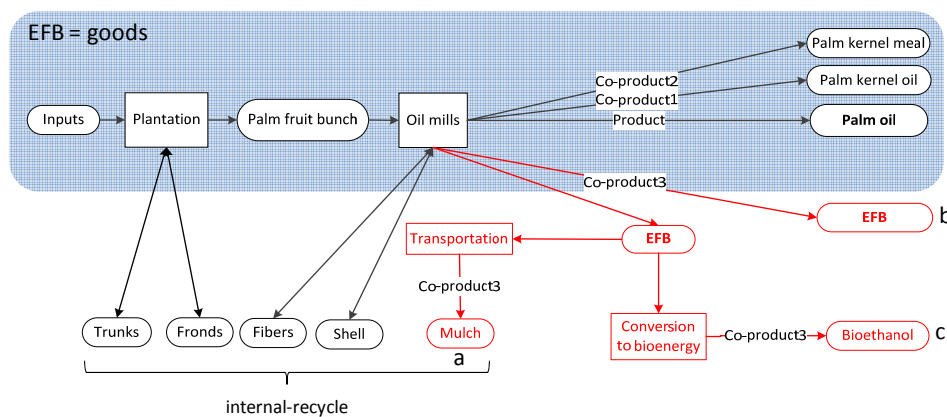

Fig. 3: System boundary of possible treatment options for EFB when valued as goods: [a] returned back to the plantation as mulch, [b] sold as a co-product, and [c] converted to bioenergy. (○ = goods or wastes; □ = unit process; ↔ = internal recycle in the plantation or oil mills; in red = EFB sub-systems; shaded = main palm oil systems)

In Scenario 3 and 4 (Figures 2c and 3c), EFB is converted into products. In this paper, the product is represented as bioenergy, specifically bioethanol. This is an external recycle case since the bioethanol product is to be used for external uses. Converting the under-utilized fraction of EFB into bioethanol, a second generation biofuel, can be seen as an option to manage residues leading to a possible improvement in environmental performances of the palm oil system. There are two unit processes used in the LCI: the first one is fermentation process to convert EFB to 95% ethanol (Ecoinvent, ID#456), the second one distillation to increase ethanol purity to 99.7% (Ecoinvent, ID#11795). In Scenario 5 (Figures 2b), EFB is treated in a waste treatment unit which is controlled incineration without energy recovery. This is chosen since open (uncontrolled) burning is prohibited. The resulted bottom ash may have a good fertilizer values, but not considered in the model. In Scenarios 6 (Figure 3b), EFB is sold as co-products for external uses.

RESULTS AND DISCUSSION

Table 2 summarizes the proposed allocation methods for each scenario. Converting the EFB into products or treating the EFB in a waste treatment unit can be solved by system expansion. In this case, a specific unit process (for example mulch, ethanol, and incinerator) is included in the LCI. More specifically, for EFB as wastes, we suggest to use 'a combined system expansion and partitioning approach'. The key feature is the possibility to split the burden between upstream (waste treatment unit) and downstream (production unit) links, depending on the technology levels of a specific unit process. This approach offers better representation the real-world situation of the system than substitution or avoided burden approach.

Table 2: Proposed allocation methods for possible treatment options and valuation of EFB in a palm oil system.

Scenario	Treatment options for EFB	EFB valuation	System boundary with reference to the palm oil system ^{*)}	Allocation methods
1	Returned back to plantation (mulch)	Wastes	Internal recycle (Figure 2a)	System expansion + partitioning
2	Returned back to plantation (mulch)	Goods	Internal recycle (Figure 3a)	System expansion
3	Converted to products (ethanol)	Wastes	External recycle (Figure 2c)	System expansion + partitioning
4	Converted to products (ethanol)	Goods	External recycle (Figure 3c)	System expansion
5	Treated in a waste treatment unit (incinerator)	Wastes	Internal waste treatment (Figure 2b)	System expansion
6	Sold as co-products to external parties	Goods	External uses (Figure 3b)	Substitution with equivalent products, or partitioning

^{*)} The term ‘recycle’ here is used quite differently than the definition given by Guinée et al (2004). In contrast to Scenarios 1 and 3, recycles in the case of Scenarios 2 and 4 do not involve burden partitioning between the upstream and downstream links since the input flow is not a functional flow, the status of the EFB is goods.

For an option to sell EFB as co-products to external parties (Scenario 6), we do not have any control on the final use of the co-products. It could be used either for example for compost, bioenergy, or pyrolysis products (biochar, biooil, syngas). Therefore, we cannot decide in advance what kind of processes to be considered by the external users. In this context, we prefer to use the term ‘substitution’ rather than ‘system expansion’ although both refer to the same multi-functional systems. In short, we used the term system expansion to refer to recycle systems and internal waste treatment (Scenarios 1-5), and substitution for external uses (Scenario 6). This is in contrast with what happen with the case of recycle (Scenarios 1-4) or internal waste treatment (Scenario 5). In this case, the specific unit processes can be determined in advance, and included in the LCI. Scenario 6 can be solved by either substitution with equivalent products or partitioning approaches. Of course, selling the EFB as co-products to an external bioenergy plant or converting the EFB (as goods) to bioenergy on-site would give the same effect provided that the same technology is used.

Six possible scenarios on the treatment of EFB in a palm oil system were presented. The effect of these different treatments on the global warming performances of CPO was evaluated based on various allocation methods. The analysis was done based on 1 FU (a palm oil system only) or 2 FUs (palm oil and EFB systems).

Table 3: Contribution analysis on global warming impact of a palm-oil system at different system boundary. (Default Ecoinvent v2.2: EFB was not modeled in the LCI)

Processes	System boundary	
	Cradle to gate	Gate to gate
Land clearance	43%	-
Plantation	36%	-
Lorry	<1%	55%
Other oil mill operations	<1%	8%
GHG (kg CO ₂ -eq/ton CPO)	1520	106

Table 3 shows that the global warming performances of a palm oil system at a ‘cradle to gate’ boundary was 1520 kg CO₂e/ton CPO, while at a ‘gate to gate’ boundary was 106 kg CO₂e/ton CPO. The contribution of the land clearance and plantation phases in this regard were so dominant that the effects of different treatment on EFB can be evaluated only at the ‘gate to gate’ boundary. Therefore, further analyses (Scenarios 1-6) are suggested to be done only in this system boundary.

CONCLUSION

The status of EFB as wastes or goods and allocation methods for multi-functional flows determines the environmental performances of a palm-oil system. Different scenarios on the treatment of biomass residues in palm oil systems require different methodological approaches in terms of system boundary and allocation methods. The suggested methodological choices offer more transparencies in the process of assessment, representing real-world situation of the system.

REFERENCES

- Chiew, YL & Shimada, S 2013, ‘Current state and environmental impact assessment for utilizing oil palm empty fruit bunches for fuel, fiber and fertilizer - A case study of Malaysia’, *Biomass and Bioenergy*, vol. 51, pp. 109-124.
- Guinée, JB (ed.) 2002, *Handbook on life cycle assessment: operational guide to the ISO standards*, Kluwer Academic Publisher, Dordrecht.
- Guinée, JB, Heijungs, R & van der Voet, E 2009, ‘A greenhouse gas indicator for bio-energy: some theoretical issues with practical implications’, *Int. J. Life Cycle Assess.*, vol. 14, no. 4, pp. 328–339.
- Hambali, E, Thahar, A & Komarudin, A 2010, ‘The potential of oil palm and rice biomass as bioenergy feedstock’, Paper presented at the 7th Biomass Asia Workshop, Jakarta, Indonesia, 29 November – 1 December.
- Hansen, SB, Olsen, SI & Ujang, Z 2012, ‘Greenhouse gas reductions through enhanced use of residues in the life cycle of Malaysian palm oil derived biodiesel’, *Bioresour. Technol.*, vol. 104, pp. 358–366.
- Hasan, MF 2010a, *Volume exports reach 15.6 million tons of CPO*, GAPKI (Indonesian Palm Oil Association), viewed 3 February 2011, <<http://en.infosawit.com/>>.

- Hasan, MF 2010b, 'Increasing competitiveness of Indonesian palm oil industry', Paper presented at the Annual MAKSI Seminar 2010, Bogor, Indonesia.
- Heijungs R & Guinée JB 2007, 'Allocation and "what-if" scenarios in life cycle assessment of waste management systems', *Waste Manag.*, vol. 27, no. 8, pp. 997–1005.
- Heijungs R & Wiloso EI 2012, 'LCA of second generation bioenergy and biomaterials: progress and problems'. *Proceedings of the The 2nd Korea-Indonesia Workshop and International Symposium on Bioenergy from Biomass*, Serpong, Tangerang, Indonesia.
- ICN (Indonesian Commercial Newsletter) 2009, *Palm oil industry in Indonesia*, <<http://www.datacon.co.id/CPO1-2009.html>>.
- Indonesian Palm Oil Association, viewed 13 October 2013, <<http://www.gapki.or.id/Page/CPOPrice?Index=7&selectedPage=0>>.
- Kusdiana, D 2013, 'Existing and new bioenergy policies needed and implementation target', Paper presented at EBTKE Conference and Exhibition 2013, Ministry of Energy and Mineral Resources of The Republic of Indonesia, Jakarta, Indonesia, 21-22 August.
- Lim, S & Lee, KT 2011, 'Parallel production of biodiesel and bioethanol in palm-oil-based biorefineries: life cycle assessment on the energy and greenhouse gases emissions.' *Biofuels, Bioprod. Bioref.*, vol. 5, pp. 132–150.
- Ministry of Agriculture 2010, *Strategic planning for plantation development 2010-2014*, Directorate General of Plantation, Jakarta.
- Sheil, D, Casson, A, Meijaard, E, van Noordwijk, M, Gaskell, J, Groves, JS, Wertz, K & Kanninen, M 2009, *The impacts and opportunities of oil palm in Southeast Asia*, CIFOR, Bogor, Indonesia.
- Singh, LA, Pant, D, Korres, NE, Nizami, AS, Prasad, S & Murphy, JD 2010, 'Key issues in life cycle assessment of ethanol production from lignocellulosic biomass: Challenges and perspectives', *Bioresource Technology*, vol. 101, pp. 5003–5012.
- Stichnothe, H & Schuchardt, F 2010, 'Comparison of different treatment options for palm oil production waste on a life cycle basis', *Int J Life Cycle Assess.*, vol. 15, pp. 907–915.
- Tillman, AM, Ekvall, T, Baumann, H & Rydberg, T 1994, 'Choice of system boundaries in life cycle assessment', *J Clean Prod*, vol. 2, no. 1, pp. 21–29.
- Van der Voet, E, van Oers, L, Davis, C, Nelis, R, Cok, B, Heijungs, R, Chappin, E & Guinée, JB 2008, *Greenhouse gas calculator for electricity and heat from biomass*, CML, Institute of Environmental Sciences, Leiden University.
- Yunus, R, Salleh, SF, Abdullah, N & Biak, DRA 2010, 'Effect of ultrasonic pretreatment on low temperature acid hydrolysis of oil palm empty fruit bunch', *Bioresource Technology*, vol. 101, no. 24, pp. 9792-9796.
- Wiloso, EI, Heijungs, R & de Snoo, GR 2012, 'LCA of second generation bioethanol: A review and some issues to be resolved for good LCA practice', *Renewable and Sustainable Energy Reviews*, vol. 16, no. 7, pp. 5295-5308.
- Wiloso, EI & Heijungs, R 2013, 'Key issues in conducting life cycle assessment of bio-based renewable energy sources', In Singh, A, Pant, D & Olsen, SI (Eds.), *Life Cycle Assessment of Renewable Energy Sources*, Springer, London, pp. 13-36.

REDUCING AMMONIA GAS CONCENTRATION FROM COMPOSTING OF LEFTOVER FOOD BY NATURAL ZEOLITE FROM JAPAN

Ida Ayu Gede Bintang Madrini^{2*}, Sakae Shibusawa¹,
Yoichiro Kojima³, Shun Hosaka⁴

¹ Institute of Agriculture, TUAT, Tokyo, Japan

² United Graduate School of Agricultural Science, TUAT, Tokyo, Japan

³ National Institute of Livestock and Grassland Science (NILGS), Nasu, Japan

⁴ Graduate School of Agriculture, TUAT, Tokyo, Japan

Email: bintang_madrini@yahoo.com (*)

ABSTRACT

This paper describes the effectiveness of natural zeolite as adsorbent of ammonia gas in composting of leftover food. A one week experiment was conducted at 5 small scale (10 l) reactor to observe decomposition process in leftover food waste and rice hull. Material mixture was added and mixed with four different doses of natural zeolite from Japan "Itaya Zeolite-13" (3%, 30%, 50% and 100% of natural zeolite by wet weight basis, respectively) in comparison with the control (0%). Ammonia gas and temperature were monitored during 1 week of composting. The temperature development in all reactors treatment from day 2 ranged from 45 to 65 °C. Between those ranges aeration (e.g. thermal convection in chamber), oxygen diffusion, the transport of gaseous compounds, moisture loss, the rate of chemical reactions, was occurred. Decreasing of final compost properties such as moisture content, organic matter and EC was caused by increasing doses of zeolite. However, pH value was increased for all treatment especially for 50 and 100% of natural zeolite. Decreased ammonia gas was started from day 2, ammonia gas range were 2100-500, 1000-100, 1300-350, 350-50, 210-30 ppm V for 0%, 3%, 30%, 50% and 100% of granular natural zeolite (<4mm) respectively. It was demonstrated that natural zeolite from Japan could be an adsorbent in composting process of leftover food waste. Reducing ammonia gas in different doses of natural zeolite was evident in this study.

Keywords: *Leftover food, rice hull, natural zeolite, ammonia gas, adsorbent.*

INTRODUCTION

Composting has been recognized as a re-using organic natural resource and environmental-friendly pursuit. However, the critical issues of the composting process known as odor have been spread as the weakness of composting. Managing odor to minimize impact still requires knowledge of the composting appropriately practiced

especially when the composting facilities located in urban area. The chemicals that commonly translate to odors at leftover food composting include ammonia, and some organic acid (Volatile Fatty Acid). Natural zeolite is used commonly because of their unique adsorption, ion exchange, molecular sieve, and catalytic properties. Some amendments such as peat, zeolite, and basalt have been used to adsorb ammonia in composting (Bernal *et al.*, 1993; Witter *et al.*, 1989). This study was conducted to describe the effectiveness of four different doses of natural zeolites as adsorbent of ammonia gas on composting of leftover food.

MATERIALS AND METHODS

Five cylindrical composting reactors (capacity of 10 L) were used (Fig.4 (left)). One thermocouple for temperature check and control were place horizontally at the center of each reactor. The cylinder was insulated with chamber to minimize the conductivity heat loss along the reactor wall (Fig.4 (right)). The temperature of chamber was controlled to follow the material temperature within 1 °C. Compressed air was introduced to the bottom of each reactor and distributed to the material mixture (Fig.1 (right)) through a perforated plate. About 30 l of leftover food (Fig.1 (left)) from lunch center was mixed with 60 l of rice hull and amended with 0.25% of lime. The natural zeolite from Japan (“Itaya Zeolite-13”) was sieved to granular (<4 mm) (Fig.2). The material mixture was added with four different doses of natural zeolite from Japan (3%, 30%, 50% and 100% of zeolite by wet weight basis, respectively) in comparison with the control (0%) and then were mixed with power mixer WPM-70A Minato Industrial Co., Ltd (Fig.3) for 5 minute. About 4.5 kg of each dose was placed in each reactor. Temperature was monitored using thermocouple and recorded. Ammonia gas was monitoring with auto-analyzer (optoacoustics system) during 1 week of composting. Final compost material was checked for some parameter such us moisture content (MC)/total solid, organic matter (OM)/volatile solid, pH, and EC. Moisture content was determined at 105 °C for 24 h and volatile solid were determined on triplicate samples at 600 °C for 2 hour. The pH and EC was measured using Horiba D-24 sensor at ratio of 1: 10 (material/compost: water).



Fig.1 Leftover food (left) and material mixture (right)



Fig.2 Granular Zeolite (<4 mm)



Fig.3 Power mixer WPM-70A

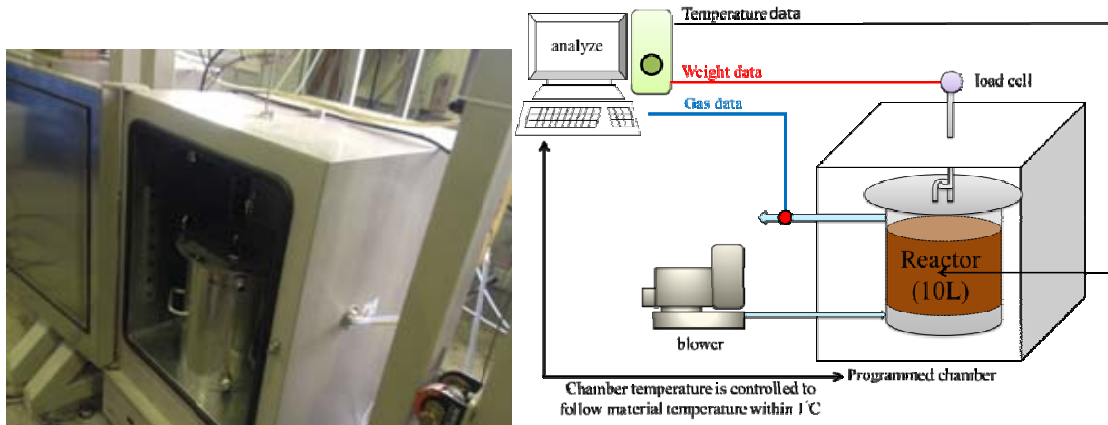

Fig.4 Composting reactor (left) and schematic of composting reactor (right)

RESULT AND DISCUSSION

The temperature development in all reactors treatment from day 2 ranged from 45 to 65 °C (fig.5). Wilbur et al (1990) stated that decreasing odor emissions at a bio solids composting facility with increasing temperature, from 46 °C up to 68 °C. Between those ranges aeration (e.g. thermal convection in chamber), oxygen diffusion, the transport of

gaseous compounds, moisture loss, the rate of chemical reactions, was occurred. Decreased ammonia gases by adsorption of different doses of granular zeolite are illustrated in figure 6. From day 2, ammonia gas ranges were 2100-500, 1000-100, 1300-350, 350-50, 210-30 ppm V for 0%, 3%, 30%, 50% and 100% of granular natural zeolite (<4mm) respectively. Witter et al (1988) also stated that high losses of ammonium nitrogen not only reduce the agronomic value of the end-product and represent a waste of a valuable resource, but also contribute to the pollution of the environment. The effect of adsorbent addition on initial and final characteristic of composting material was shown in figure 7 and 8. Decreasing in moisture content, organic matter and EC was caused by increasing doses of zeolite. However, pH value was increased for all reactors treatment especially for 50 and 100% of natural zeolite. The result confirmed with statement of Vuorinen et al 1997; Day et al., 1998 that during the composting process the biologically degradable organic matter is converted into volatile CO₂ and H₂O and is removed from the compost and the total N content increases which results in a C/N decrease toward the end of composting.

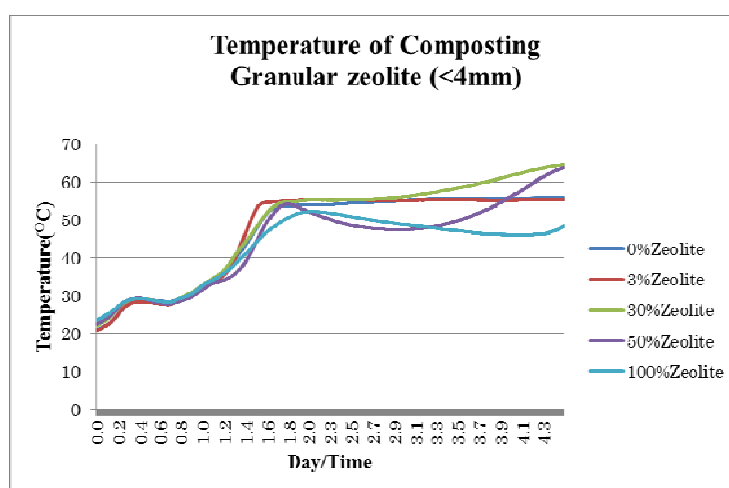

Fig.5 Temperature profile

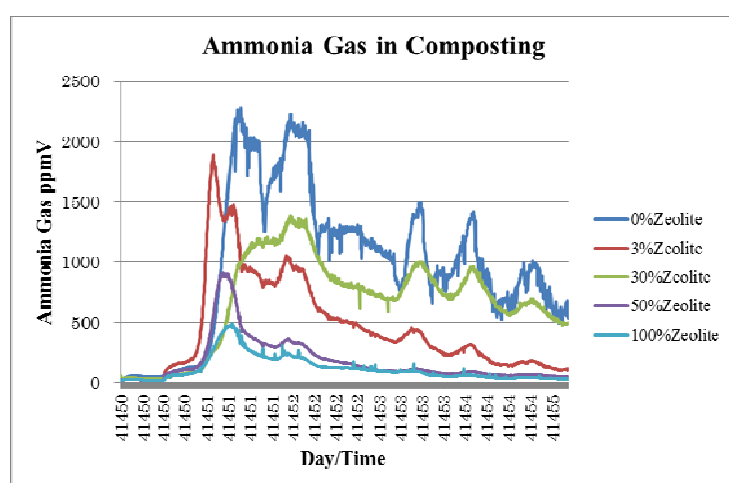

Fig.6 Change in Ammonia Gas during Composting

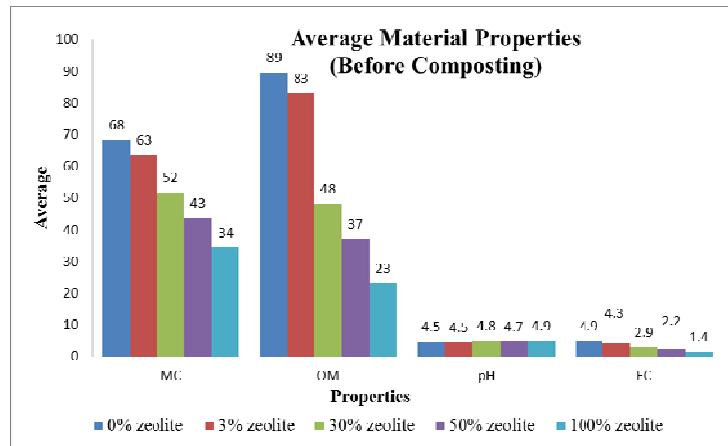

Fig.7 Initial characteristics of composting material

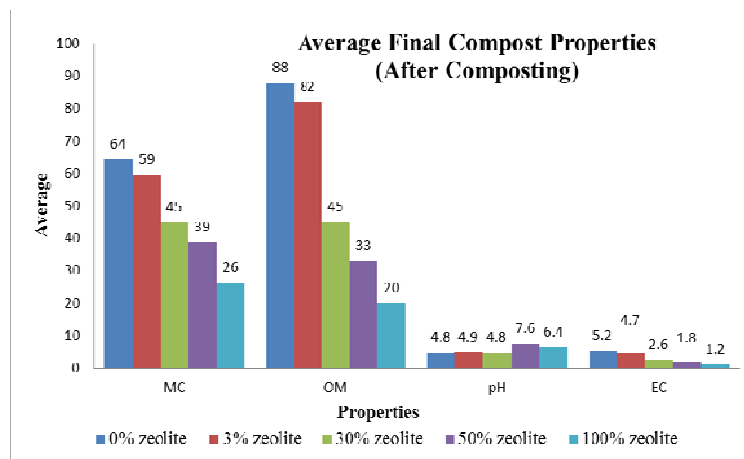

Fig.8 Final characteristic of compost material

CONCLUSIONS

1. It was demonstrated that natural zeolite from Japan “Itaya Zeolite-13” could be an adsorbent in composting process of leftover food waste.
2. Reducing ammonia gas in different doses of natural zeolite from Japan “Itaya Zeolite-13” in the form of granular (<4mm) was evident in this study.

REFERENCES

- Bernal, M.P., Lopez-Real, J.M., Scoot, K.M., 1993. ‘Application of natural zeolite for the reduction of ammonia emission during the composting of organic waste in laboratory composting simulators’. *Bioresource Technology* 43, 35-39.
- Vuorinen, A.H., Saharinen, M.H., 1997. ‘Evolution of microbiological and chemical parameters during manure and straw co-composting in a drum composting system. *Agric. Ecosyst. Environ.* 66, 19-29

- Wilber, C., and C. Murray, 1990. 'Odor Source Evaluation'. *BioCycle* 31(3):68-72.
- Witter, E., Lopez-Real, J., 1988. 'Nitrogen losses during the composting of sewage sludge, and the effectiveness of clay soil, zeolite, and compost in adsorbing the volatilized ammonia'. *Biol. Wastes* 23, 279–294.
- Day, M., Krzymien, M., Shaw, K., Zeremba, L., Wilson, W.R., Botden, C., Thomas, B., 1998. 'An investigation of the chemical and physical changes occurring during commercial composting'. *Compost Sci. Util.* 6, 44–66.

A STUDY OF SOIL ADSORPTION TOWARD CHROMIUM IN LIQUID WASTE FROM TANNING INDUSTRY

Agung Sahida, Sari Virgawati, and AZ. Purwono Budi Santosa

Department of Agro-Technology, Faculty of Agriculture,

UPN "Veteran" Yogyakarta

e-mail: agung.shd@gmail.com (+6285743038169)

ABSTRACT

Tanning industry potentially produces waste containing heavy metals chromium (Cr) is harmful to the environment. One of the methods to decrease the Cr in liquid waste is using soil as adsorbent. Soil capacity to adsorb of heavy metal is determined by clay content, soil moisture, redox potential, pH, organic matter content and CEC. This research aimed to determine the soil capacity of Vertisol, Oxisol, Entisol, and Andisol to adsorb Cr in liquid waste from tanning industry. The experiment conducted in this research was to flow and saturate the liquid waste into soil column four soil samples. The adsorption capacity of each soil type was calculated by comparing Cr content in the soil with it in the filtrate. The results showed that the soil is a good Cr adsorbent and each soil type has different abilities in the adsorption of heavy metals Cr. At first saturating the soil is able to adsorb Cr about 99.92%, the second saturation at 99.64%, and the third saturation of the soil is able to adsorb Cr 97.17%. The adsorption capacity of Entisol and Oxisol was 0.174 mg/g, Andisol has an adsorption capacity of 0.175 mg/g, and Vertisol has adsorption capacity of 0.177 mg/g.

Keywords: *Chromium (Cr), Soil Adsorption, Tanning Industry.*

INTRODUCTION

One of the negative effects from industrial development is the increase of industrial waste amount that is possibly harmful and hazardous. Heavy metals is categorized in B3 waste (Hazardous and Harmful Materials) that, in a specific content, can harm its surrounding environment because it is toxic for plants, animals, and humans.

Tanning industry is one of the industries that potentially produce waste containing harmful heavy metals such as Chromium (Cr). This is happened because the materials used in the process are mostly a mixture of Na_2S , $\text{Ca}(\text{OH})_2$, H_2SO_4 , NaCl , dan Cr.

The maximum limit of Chromium allowed for Cr based on the State Minister for the Environment policy is 0.6 ppm. Meanwhile, according to research conducted by Fadilah (2011), characteristic of waste from tanning industry that has passed through Liquid Waste Processing Installation (IPAL) still contain Chromium of 41.37 ppm.

The prevention of heavy metals contamination to the environment can be performed in several methods. The most practical method is sedimentation which is followed by filtering, absorbing by using active carbon, natural zeolite and also soil.

The adsorption method by soil in solving the problem of waste contaminated by heavy metals is relatively simple and easy to be performed. In addition, soil has high adsorption capability, renewable, easy to get, and abundant.

Objective

The objective of this research is to determine the soil capacity of Vertisol, Oxisol, Entisol, and Andisol to adsorb Cr from the liquid waste of tanning industry.

Soil Contamination

Matters that can cause soil contamination are liquid waste or industrial chemical material leakage, use of pesticide, permeation of contaminated surface water into sub-surface layer, oil-contaminated vehicle accident, chemical substance, or waste; liquid waste from the waste dumping area, and also industrial waste that is dumped directly to the soil without obeying the regulations (Illegal dumping) (Sofyan, 2009).

The critical limit of heavy metal concentration in soil, water, and plant can be noticed in Table 1.

Table 1. The critical limit of heavy metal concentration in soil, water, and plant

Heavy Metals	Soil (ppm)	Water (ppm)	Plant (ppm)
Pb	100.00	0.03	50.00
Cd	0.50	0.05-0.10	5-30
Co	10.00	0.4-0.6	15-30
Cr	2.50	0.5-1.0	5-30
Ni	50.00	0.2-0.5	5-30
Cu	60-125	2-3	20-100
Mn	1500.00	-	-
Zn	70.00	5-10	100-400

Source : State Ministry for Population and Environmental of Indonesia (Dalhousie, 1992)

According to Palar (1994), soil has a significant role on the transfer and the washing of pollutant. Soil is also categorized as a pollutant carrier. The transfer process can be divided into three which are flow on, absorption, and leaching. If there is an accumulation from the metals, it will cause an environmental effect. The very last and highest accumulation of metals happens in the soil because of the forceful clay colloids absorption in the soil (Alloway, 1995).

Tanning Industry

Tanning industry is an industry that process raw hides or skins into hides or leather by using tanning material (Zaenab, 2008). Tanning industry is one of the industries that have potential to harm the environment. The average amount of tanning industry waste

is 8,000 – 12,000 gallon per 1,000 pound of processed wet hides. The average content of waste is 8,000 ppm of total solids, 1,000 ppm of protein, 300 ppm of NaCl, 1,600 ppm of total hardness, 1,000 ppm of sulfide, 40 ppm of chromium, 60 pp of nitrogen, and 1,000 ppm of BOD. Those wastes have pH value between 11 and 12, and normally will produce 5 – 10% of sludge concentration because of chalk content and sodium sulfide. While in USA, from 1 tons of raw hides, it produces 600 kg of solid waste and contains 60,000 metric tons of high-content chromium (Cabeza *et al.* 1998).

Based on the research conducted by Fadilah (2011), the characteristic of tanning industry waste are as follow:

Table 2. The analysis result of physical and chemical factor of tanning industry waste

No	Parameter	Maximum Content (ppm)	Result (ppm)
1	BOD	50	102.3
2	COD	110	180.5
3	Chrome	0.6	41.37
4	TSS	60	107
5	Sulphide	0.8	0.02

Table 3 shows the standard of liquid waste that has to be fulfilled by all tanning industry made by State Ministry for the Environment No: KEP-51/MENLH/10/1995 about the standard of liquid waste for industrial activity.

Table 3. The standard of liquid waste for tanning industrial activity

Parameter	Tanning Process By Chrome		Tanning Process By Leaves	
	Maximum Content (mg/L)	Maximum Contamination Load (kg/tons)	Maximum Content (mg/L)	Maximum Contamination Load (kg/tons)
BOD	50	2	70	2.8
COD	110	4.4	180	7.2
TSS	60	2.4	50	2
Total Chrome	0.6	0.024	0.1	0.004
Oil/Fat	5	0.2	5	0.2
Total N	10	0.4	15	0.6
Total Ammonia	0.5	0.02	0.5	0.02
Sulphide (S)	0.8	0.032	0.5	0.02
pH	6.0-9.0		6.0-9.0	
Maximum waste discharge	40 m ³ /tons of raw material		40m ³ /tons of raw material	

Soil as Heavy Metals Adsorbent

Soil has a limited ability or capacity in performing retention and accumulating the heavy metals. If this limitation is lapsed then the pollution will happen. Soil capacity in

performing retention, absorbing, and accumulating heavy metals is determined by clay content, soil moisture, redox potential, pH, organic material content and cation change capacity (CEC) (Bohn *et al.*, 1979 *cit* Jones dan Jarvis, 1981).

Soil reaction is an important controlling factor of chemical activity of metals and any other important process in the soil. By the increase of pH, the ionic form from micro unsure cation changes into hydroxide or oxide form. (Soepardi, 1983). Alloway (1995) also proposed that generally heavy metals cation moves easier in the sour condition and the increase of pH by calcification decrease the heavy metals availability for the living creature.

Organic material can reduce the negative effect that is possibly caused by heavy metals and maintain the plant in normal condition (Stevenson, 1994). Research by Ariyanto *et al.* (2005) proposed that from the metal content analysis, in this case is Chromium (Cr), the decrease of Cr content in the soil is followed by the result about higher organic material content.

Adsorption and cation change have a practical role which is very important in the nutrient adsorption of plant, soil fertility, nutrient retention, and fertilization (Tan, 1991). The soil clayey usually contains electronegative content which enables the cation change reaction. The CEC value is influenced by its negative content source and also by the soil texture and the amount of colloid in the soil. (Soepardi, 1983).

MATERIAL AND METHODS

The soil sample used in this research was taken from several locations in order to get different soil types, which are:

- a. Andisol is taken from Dieng plateau, Wonosobo Regency.
- b. Oxisol is taken from Patuk Sub district, Gunungkidul Regency, Yogyakarta.
- c. Entisol is taken from Piyungan Sub district, Bantul Regency.
- d. Vertisol is taken from Donggubah, Wonosari Sub district, Gunungkidul Regency, Yogyakarta.

The soil sample was top soil and sub soil part. The tanning industry liquid waste was taken from tanning industry in the Sitimulyo Industrial Area, Piyungan, Bantul.

In the experiment, the liquid waste from tanning industries which was indicated to be contaminated by heavy metals Cr was flowed in the same volume and saturated on each soil type, and then the filtrate was contained. After the filtrate from the first saturation had been depleted and the soil had reached the field capacity, then the second saturation was performed followed by the third saturation. All treatments were performed three times on each soil type. Afterward, Chromium content in the filtrate produced from those saturations were analyzed in the laboratory.

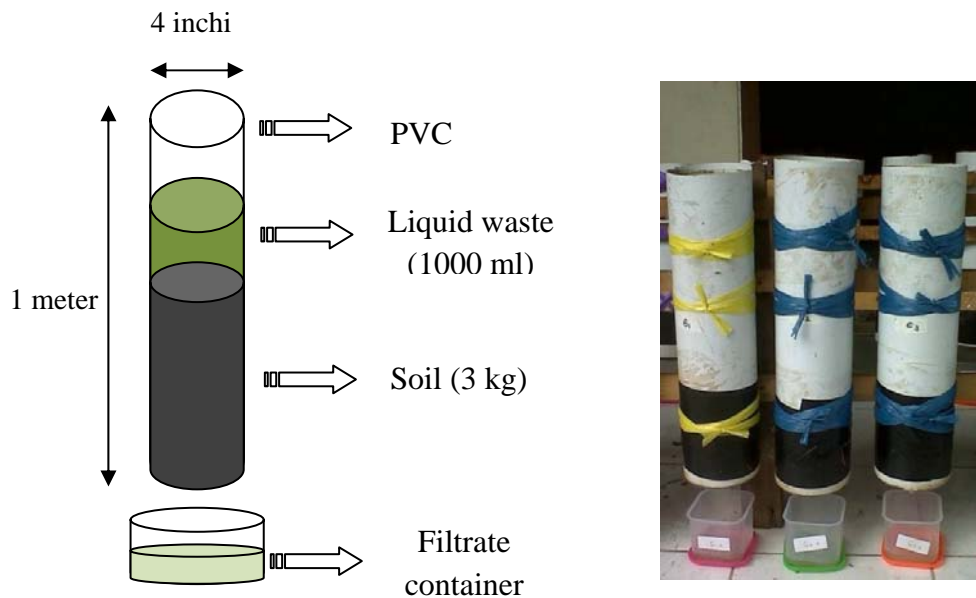

Figure 1. The Outline of Saturation Process of Liquid Waste from Tanning Industry

RESULT AND DISCUSSION

These are data from the analysis result of liquid waste, filtrate, and soil adsorption capacity measurement in the first, second, and third saturation.

The data obtained in this research shows that the total Chromium content in the liquid waste from tanning industry that has not been processed is 530.43 ppm, while the maximum limit allowed is 0.60 ppm. This high Chromium concentration in the liquid waste is occurred because in the tanning process, it usually uses tanning material $\text{Na}_2\text{Cr}_2\text{O}_7$ (Natriumdikhromat) which is subsequently reduced by gas SO_2 and formed into $\text{Cr}(\text{OH})\text{SO}_4$. This will be harmful for the environment and the living creature if it is flowed and spread just like that.

Table 4. Soil capacity to absorb Cr in the first saturation

Soil type	Cr-Total (ppm)		Saturation 1 (ppm)		Adsorption Capacity (mg/g)
	Soil	Liquid Waste	Cr-Filtrate	Cr-Adsorbed	
Vertisol Topsoil	0.4	530.4310	1.0613	529.3698	0.176457
Vertisol Subsoil	3.5	530.4310	0.0391	530.3919	0.176797
Oxisol Topsoil	0	530.4310	0.8119	529.6191	0.176540
Oxisol Subsoil	0	530.4310	0.0213	530.4097	0.176803
Entisol Topsoil	9.6	530.4310	1.2448	529.1862	0.176395
Entisol Subsoil	4.2	530.4310	0.1514	530.2796	0.176760
Andisol Topsoil	5.0	530.4310	0.0213	530.4097	0.176803
Andisol Subsoil	0	530.4310	0.0213	530.4097	0.176803

Table 5. Soil capacity to absorb Cr in the second saturation

Soil type	Cr-Total (ppm)		Saturation 2 (ppm)		Adsorption
	Soil	Liquid Waste	Capacity (mg/g)	Cr-Adsorbed	Capacity (mg/g)
Vertisol Topsoil	529.77	530.4310	0.1168	530.3142	0.176771
Vertisol Subsoil	533.89	530.4310	0.5945	529.8365	0.176612
Oxisol Topsoil	529.62	530.4310	9.8343	520.5967	0.173532
Oxisol Subsoil	530.41	530.4310	0.3732	530.0578	0.176686
Entisol Topsoil	538.79	530.4310	1.1348	529.2962	0.176432
Entisol Subsoil	534.48	530.4310	2.5291	527.9019	0.175967
Andisol Topsoil	535.41	530.4310	0.4108	530.0202	0.176673
Andisol Subsoil	530.41	530.4310	0.0213	530.4097	0.176803

Table 6. Soil capacity to absorb Cr in the third saturation

Soil type	Cr-Total (ppm)		Saturation 3 (ppm)		Adsorption
	Soil	Liquid Waste	Cr-Filtrate	Cr-Adsorbed	Capacity (mg/g)
Vertisol Topsoil	1060.08	530.4310	0.4702	529.9608	0.176654
Vertisol Subsoil	1063.73	530.4310	0.8808	529.5502	0.176517
Oxisol Topsoil	1050.22	530.4310	36.7483	493.6827	0.164561
Oxisol Subsoil	1060.47	530.4310	10.9170	519.5140	0.173171
Entisol Topsoil	1068.08	530.4310	11.6217	518.8093	0.172936
Entisol Subsoil	1062.38	530.4310	36.1242	494.3068	0.164769
Andisol Topsoil	1065.43	530.4310	21.6697	508.7613	0.169587
Andisol Subsoil	1060.82	530.4310	1.4503	528.9807	0.176327

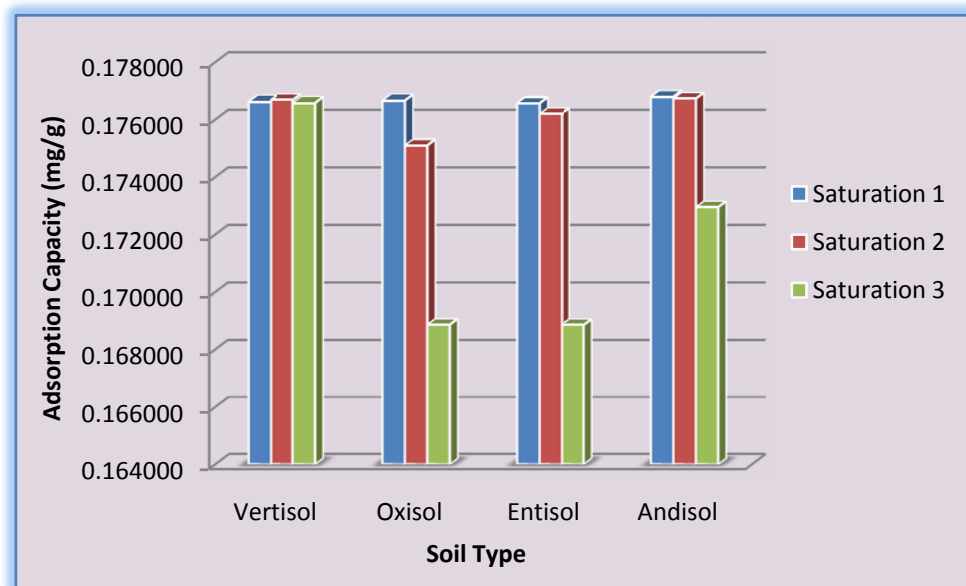

Figure 2. The Chart of Soil Adsorption Capacity toward Chromium

From the experiment, it is proved that soil can function as a good adsorbent for Chromium. This can be observed on Table 4, 5, and 6 showing that the soil adsorbing capacity from the three saturations still shows good result.

In the first saturation, the soil can absorb Chromium in the average of 99.92%. The Chromium concentration in the filtrate is still below the maximum limit allowed.

In the second saturation, the soil adsorption capacity is decreased into 99.64%. The vertisol and andisol capacity are stable and not decreasing compared to oxisol and entisol. Moreover, the filtrate produced by these two soil type is still below the maximum limit allowed by the State Minister for the Environment.

In the third saturation, the soil adsorption capacity decreases again, but the basic adsorption capacity is still high in the range of 90%. This shows that the soil can accumulate huge amount of Chromium. From this experiment, the soil has accumulated Chromium more or less in the amount of 1,500 ppm.

A. The Adsorption Capacity of Vertisol

The physical and chemical characteristic of vertisol is very influential toward the soil capacity to absorb Chromium. In this case, high clay content and Cation Exchange Capacity (CEC) has a significant role in the Chromium adsorption. Vertisol has high clay content and also high CEC so that it supports the cation change process. Since clay colloid has negative charge while Chromium has positive charge, then the Chromium will be dragged toward the clay particle and bounded electro-statically on the clay surface. Clay has tiny particle and enormous surface area that enables to absorb great amount of Chromium.

Tan (1991) proposed that mineral montmorillonite is categorized as unique element from clay in the soil Vertisol, Mollisol, and Alvisol, and also found in several Entisol. Plasticity potential and high swelling-shrinking of this type of mineral causes these soils to have plasticity characteristic in wet condition and hard if it in dry. The high swelling-shrinking potential causes this mineral to be able to receive and fasten the ionic of the metal and organic compound. Besides, mineral montmorillonite also has specialty that adsorption by the clay surface can occur not only on the outer surface but also can penetrate into inter micelles area.

Vertisol here also has a small particle, so that the soil tends to be more compact and difficult to flow the liquid waste of tanning industry. The soil which has soft texture and is dominated by clay will have more total pore space and mostly constructed by micro pores so that it has higher water holding capacity. This high water holding capacity will have an influence toward the soil adsorption capacity because the soil will absorb more liquid waste from tanning industry.

The use of vertisol as adsorbent of Chromium will be more effective if the problem on the physical characteristic that is difficult to loosen the water can be solved. To solve these problems, vertisol characteristic can be improved by combining vertisol and other soil types for heavy metals adsorbent.

B. The Adsorption Capacity of Oxisol

Although oxisol has a higher clay content than vertisol, due to different clay type contained it may caused the soil adsorption capacity of oxisol to be still lower than vertisol.

Oxisol in this research has higher organic content than vertisol and entisol. The high organic content in oxisol will affect the soil adsorption toward Chromium.

Stevenson (1982) in Ariyanto (2001) proposed that tar form organic material can control the availability of metal in the soil. The other evidence of chelating is the research conducted by Ariyanto et al. (2005), proposed that from the analysis of metal content, in this case Chromium, the decrease of Cr content occurs in the soil followed by the result about higher organic material content. From the analysis result, it can be concluded that the decrease of Chromium is caused by the chelating of organic material toward Chromium.

Although oxisol has higher organic material content, it has lower CEC compared to other types of soil. Besides, clay contained in oxisol is kaolinite type (1:1) with surface area range only between 7 to 30 m²/g and much smaller than any other types of clay. This can enable good oxisol adsorption capacity to absorb Chromium in the starting saturation, while in the second and third saturation, the adsorption capacity then been decreased.

C. The Adsorption Capacity of Entisol

Entisol texture is dominated by sand fraction so that it has bigger soil particle compared to other soil types. With a bigger or coarse soil particle, it can create a bigger soil pore size as well. The effect is that the saturated liquid waste will be easier to pass soil column and less Chromium will be absorbed in the soil.

Entisol also has less organic material content compared to other soil types. This low organic material content and less clay content will reduce the amount of colloid in this soil. This enables the decrease of Chromium adsorption capacity and much faster to decrease.

D. The Adsorption Capacity of Andisol

The characteristic of andisol is very dark, very porous, containing organic material and clay in the type of amorphous, especially allophane and also slight silica, alumina, or metal-hydroxide (Darmawijaya, 1990). Van Olphen (1977) *cit.* Tan (1991) proposed that specific surface area of allophane type is around 100 to 800 m²/g, so that andisol will have a wide cation adsorption area.

Organic material will form colloidal topsoil which has greater cation adsorption capacity than clay, so that the organic material contained in andisol has a crucial role in the process of Chromium adsorption.

The physical characteristic of andisol which has low bulk density and also high water holding capacity will be useful in the Chromium adsorption because in this research, Chromium contained in the liquid waste is saturated into the soil.

CONCLUSION

Based on the research result, it can be concluded that soil is a good Chromium adsorbent. Vertisol, Oxisol, Entisol, and Andisol have different adsorption capacities toward Chromium. Vertisol has an adsorption capacity in the amount of 0.177 mg/g, Oxisol and Entisol in the amount of 0.174 mg/g, while Andisol in the amount of 0.175 mg/g.

REFERENCES

- Alloway B. J. (1995). Heavy metal in soils. Blackie Academic and Profesional; London.
- Ariyanto, DP. (2001). Pengaruh Jarak Buangan Air Limbah Industri di Daerah Jaten–Karanganyar Terhadap Kadar Cu dan Cr dalam Air dan Tanah Permukaan Saluran Air Pungkuk. Skripsi. Fakultas Pertanian Universitas Sebelas Maret Surakarta.
- Ariyanto, DP., Indro W., Hery W. (2005). Pengaruh Jarak Buangan Air Limbah Industri di Daerah Jaten – Karanganyar Terhadap Kadar Chromium dalam Air dan Tanah Permukaan Saluran Air Pungkuk. Caraka Tani 5 (2) : 20-29.
- Bapedal. (1995). Kep-01/Bapedal/09/1995 : Tata Cara Dan Persyaratan Teknis Penyimpanan Dan Pengumpulan Limbah Bahan Berbahaya Dan Beracun. Bapedal (Badan Pengendalian Dampak Lingkungan). Jakarta.
- Cabeza, L.F, and M.M. Taylor, (1998). Process of Leather Waste. Water Management Journal, pp. 211- 214. US Department of Agriculture, Agricultural Research Service; USA.
- Darmawijaya, M. I. (1990). Klasifikasi Tanah. Gajah Mada University Press.Yogyakarta.
- Fadilah, A. (2011). Toksisitas Limbah Penyamakan Kulit Terhadap Daphnia. Universitas Pendidikan Indonesia; Bandung.
- Jones, L. H. P. and S. C. Jarvis. (1981). The fate of heavy metals. In Greenland, D. J. and M. H. B. Hayes (ed) : The Chemistry of Soil Processes. A Willey Interscience Publ. John Wiley & Sous Ltd. Chichester, New York..
- Ministry of State for Population and Enviromental of Indonesia, and Dalhousie, University Canada (1992), Environmental Management in Indonesia. Report of Soil Quality Standars for Indonesia. *Dalhousie University Canada*.
- Palar, H. (1994). Pencemaran dan Toksikologi Logam Berat. Rineka Cipta; Jakarta.
- Soepardi. G. (1983). Sifat dan Ciri Tanah. Departemen Tanah. Fakultas Pertanian, IPB. Bogor.
- Sofyan, A. (2009). Pencemaran Tanah. <http://personal.ftsl.itb.ac.id/asep/profile/pencemaran-tanah/>. Diakses : 27 Mei 2012.
- Stevenson, F.J. (1994). Humus Chemistry: Genesis, Composition, Reactions. 2nd ed. Wiley Interscience Publ. John Wiley & Sons. New York.
- Tan, K. H. (1991). Dasar-Dasar Kimia Tanah. Gajah Mada University Press; Yogyakarta.

Zaenab, (2008). Industri Penyamakan Kulit dan dampaknya terhadap lingkungan. <http://keslingmks.wordpress.com/2008/08/18/industri-penyamakan-kulit-dan-dampaknya-terhadap-lingkungan/>. Diakses 27 Mei 2012.

GROWTH AND LEAVES DIGITAL IMAGE ANALYSIS OF RICE CULTIVATED IN VARIOUS LEVELS OF NITROGEN CONCENTRATION AND BROWN PLANTHOPPER INFESTATION

Partoyo¹, Mofit Eko Purwanto¹, Sari Virgawati¹, Frans Richard Kodong², Sri Sumarsih¹

¹Agrotechnology Department, Faculty of Agriculture

²Informatics Department, Faculty of Industrial Technology

UPN "Veteran" Yogyakarta

* Corresponding author: partoyo@upnyk.ac.id

ABSTRACT

The information of recommended fertilizer dosage and pest control that is location-specific is required by the farmer for the success of its agricultural cultivation. In this research, digital image analysis of the rice leaf sample was conducted to obtain a basis data for determining its nutrient sufficiency status and pest attack level. Hydroponic rice planting is performed in the green house with variations of nitrogen sufficiency and variations of brown planthopper population. Along the rice crop development, rice leaf photography is performed to capture the digital image of rice leaf from various treatments of nitrogen sufficiency variation, pest attack level variation, and plant period variation. The process of digital image processing is performed to obtain image parameter, which are Red (R), green (G), dan blue (B). The variation of nitrogen content from 10% - 150% of recommended dosage produces various rice leaf greenness, amount of tillers, amount of panicles, and plant biomass weight. The increase of nitrogen content from 10% - 150% causes color diversity from greenish yellow with the value of R: 86, G: 131, and B: 46, to dark green with the value of R: 119, G: 169, and B: 72. Rice crop that is attacked by brown planthopper changes from green with the value of R: 206, G: 193, and B: 159 into brownish yellow with the value of R: 196, G: 98, and B: 86 along with the increase of it population.

Keywords: rice crop, nitrogen, planthopper, digital image.

INTRODUCTION

In 2014, the government targets a surplus of hulled rice in the amount of 10 million tons (Tri, 2012). The production means whose role is very vital in supporting the national rice production improvement is fertilizer. The recommendation of N, P, and K fertilizing on the Rice of Location-Specific Rice Field is regulated with Minister of Agriculture Regulation No. 40/Permentan/OT.140/04/2007 (Deptan RI, 2007). However, this recommendation has a limitation such as this recommendation is assembled on district level. The actual fertilizer dosage also can be lower than recommended dosage if its soil fertility variability is high. The use of PUTS is limited to the availability of equipments in the field so that the farmer cannot use it when needed (Virgawati, 2010). The productivity levelling off and the increase of fertilizer

price is a stimulation to improve the efficiency of agro-business system especially the efficiency of fertilization on rice field which is the biggest fertilizer consumer. Therefore, the determination of precise fertilizer dosage becomes urgent for achieving an efficient fertilization.

In 2010, *Education for Sustainable Development* (ESD) UPN “Veteran” Yogyakarta research team conduct a research about the application of *Precision Agriculture* (PA) concept and technology in several district in Magelang Regency (Virgawati *et al.*, 2010). *Precision Agriculture* designs soil and crop management carefully according to diversity that is found in the land (Shibusawa, 2001). Plant and characteristic of soil in the land is not only varied on distance and depth, but also time. This diversity problem becomes the basic difference between *Precision Agriculture* dan *Conventional Agriculture* (Srinivasan, 2006).

Pest attack often becomes a problem in the rice productivity improvement effort. The main rice pest in Indonesia is green planthopper and brown planthopper. Green planthopper is a vector that spreads ‘tungro’ disease while brown planthopper spreads dwarf virus. This pest can form a huge population only in a short time and damage plants on every single growth phase. Planthopper attack can cause a loss whose amount is depended on the attack level, from low attack level until fail to pay back level (Anonim, 2010).

This research is designed to produce information especially recommended fertilizer dosage and pest control that is location-specific. For that reason, digital image analysis of the rice leaf sample was conducted to obtain a basis data for determining its nutrient sufficiency status and pest attack level. This research is aimed to assemble technology that combines *artificial neural network* (ANN) technique with digital image data communication technique to determine fertilizer need and pest control recommendation. This technology is designed so that the farmer can find out recommended fertilizer dosage and pest control recommendation needed for the agricultural land only by sending data in the form of rice leaf image through short messages (MMS) to the system.

MATERIALS AND METHODS

The details of each phase are as follow:

A. Hydroponic rice planting in green house with nitrogen nutrient sufficiency variation and pest attack level variation.

1. This phase begins with preparing plant media in the form of river sand. Before used, the sand is cleansed with tap water until the water is clear. The aim is to remove materials except sand that are possible to carry nutrition.
2. Planting is performed in 69 plastic pots, consists of 23 treatments with 3 repetitions. The variety chosen is Ciherang with consideration as the most popular variety that is planted in the research area and shows a clear visual indication of planthopper attack.
3. The liquid media of hydroponic is prepared with complete nutrient composition which is based on the need of rice crop according to IRRI (Yoshida *et al.*, 1976), except for the nitrogen content, variations of sufficiency percentage are made with the value of 10%, 20%, 30%, 40%, 50%, 60%, 70%, 80%, 90%, 100%,

110%, 120%, 130%, 140%, 150%. Meanwhile, for the pest attack treatments, rice is planted with optimum hydroponic media composition (100%) and infested with brown planthopper with population 1, 2, and 3 pair of adult planthopper (age of 4 days) with male and female comparison of 1:1 to arouse pest attack level variations.

4. The plant is kept until harvest age.

B. Observation of plant growth and planthopper population

1. Growth of the rice plant was observed for plant height, wet and dry weight of plant biomass, amount of tiller, and amount of panicle per pot.
2. Population of planthopper was observed every week from week 1 until week 7 to monitor the population change.

C. Photography of hydroponic rice leaf in green house.

1. This photography is performed to record digital image of rice leaf from various treatments of nutrient sufficiency variation, pest attack level variation, and plant age variation. This photography is performed by using digital camera Canon EOS 500D.
2. This photography is performed on selected leaf sample that has been completely developed (*fully expanded leaf*), starting from plant age of three weeks after transplanting (WAT) in 10 days of interval. This photography is performed until it comes into bud.

D. Parameter analysis of the digital image of rice leaf.

The process of digital image processing is performed to obtain image parameters, which are: Red (R), Green (G), dan Blue (B).

RESULT AND ANALYSIS

The plant height is mostly ranged between 95 and 105 cm. There are two treatments that produce plant height below 90 cm, i.e. 30% and 130% N concentration. The four topmost plant heights are treatment of 70%, 80%, 90%, and 100% (Figure 1). This result indicates a better nitrogen sufficiency in those four levels of nitrogen concentration.

The average amount of tillers per hill shows the mode in between 80% and 110% N concentration (Figure 2). It might be said that optimum nitrogen content for tillering is around 80% to 110% of recommended concentration. Lower or higher N concentration is resulted in the lesser amount of tiller per hill.

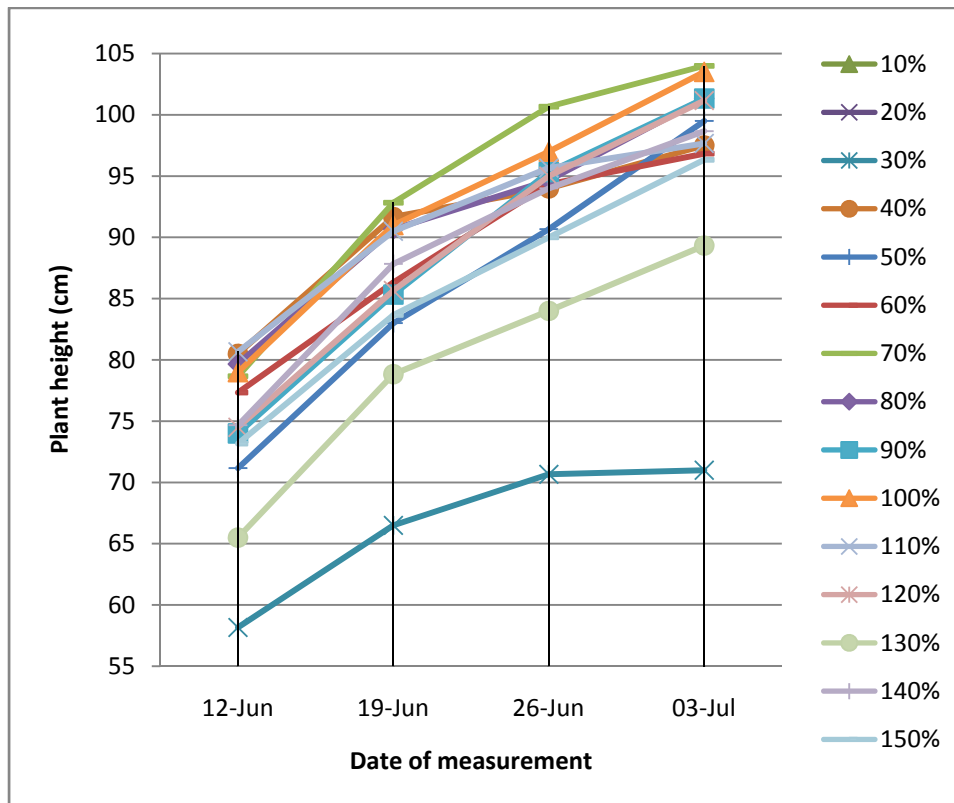

Figure 1. The average height of rice crop up to maximum vegetative

The pattern of amount of tiller per hill is similar to the average amount of panicles per hill (Figure 3). The weight of panicles per hill is connected with the amount of panicles per hill so that the weight diversity of panicles is similar with the amount of panicles per hill pattern (Figure 4). It can be seen that the most weight panicle was produced by 100% N concentration treatment.

The weight of plant tissue which includes straw and root shows that on treatment with nitrogen content higher than 100% until 150% produced plant tissue weight that is similar to treatment with nitrogen 100% (Figure 5). The rice straw on treatment with high nitrogen content (above 100% of dosage) still shows a high vegetative growth during panicles maturation. One of the indications is the leaf which tends to be constant in green although the panicles have turned into yellow until harvest age. Nevertheless, the produced tissue contained less dry weight as compared to 100% N concentration treatment (Figure 5).

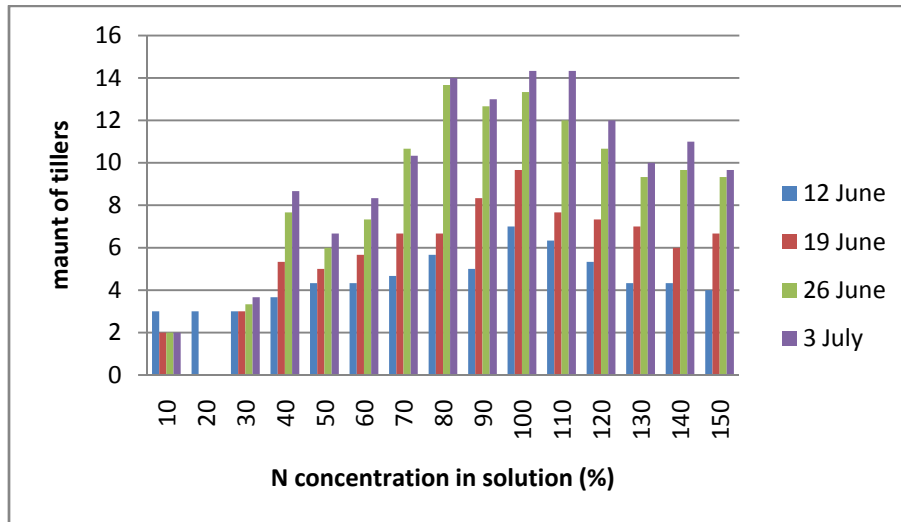

Figure 2. The average amount of tillers per hill at the harvest time

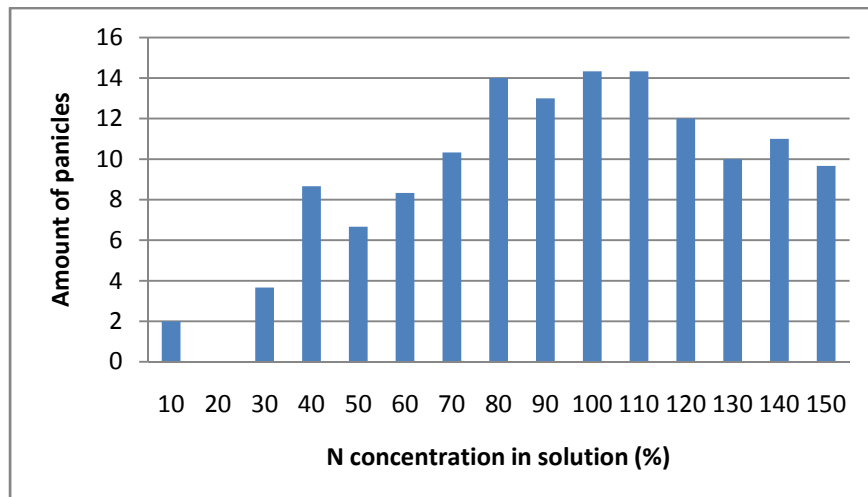

Figure 3. The average amount of panicles at the harvest time

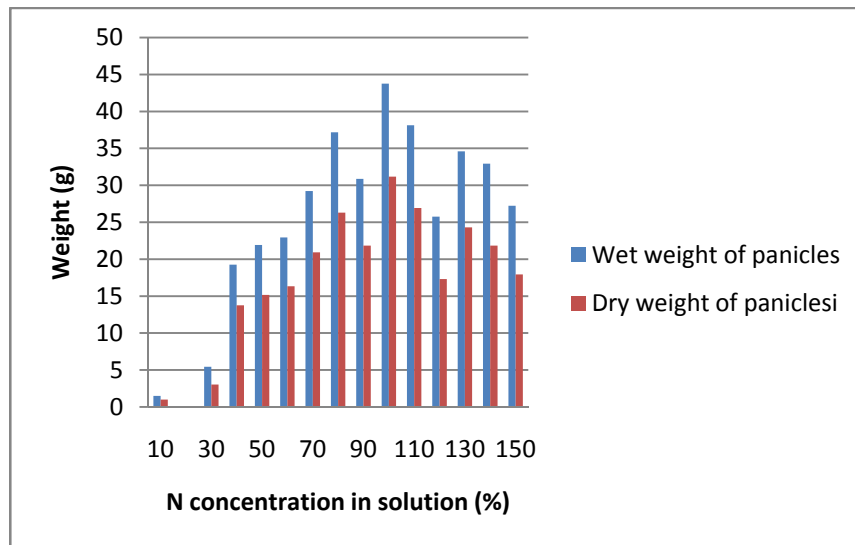

Figure 4. The average wet and dry weight of panicles

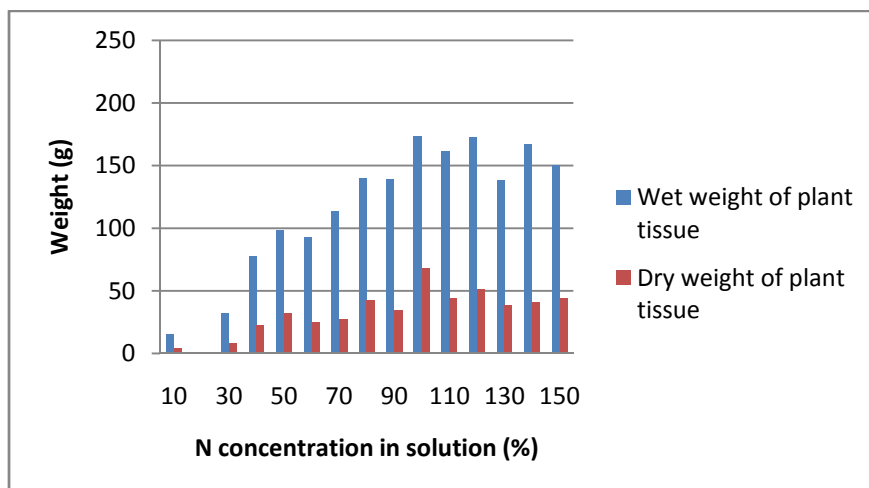

Figure 5. The average wet and dry weight of plant tissue

The experiment pot that is infested with brown planthopper is made into three limits of initial planthopper population with three repetitions and it uses hydroponic nutrition composition with 100% of nitrogen content. The experiment pot of brown planthopper attack is given a cover made from mica sheet. The infestation of brown planthopper is performed when the rice crop attains the age of 1 week. The population of brown planthopper is observed every 7 days so that the fluctuation of planthopper population can be obtained. The initial population of brown planthopper influences the population development. The rice crop that is infested with adult brown planthopper (imago at the age of 4 days) with higher initial population will develop its population faster. The population of brown planthopper with three pair initial population is developed faster than two pair and one pair initial population. This rapid population increase is followed by rapid decrease as well. Rice crop that is relatively young is more sensitive toward brown planthopper attack, so that the high population will rapidly decrease its ability to provide nutrition for the next offspring. The low initial population will increase

population slowly and the crop damage as well, so that the population of brown planthopper will decrease slowly as the plant is increasingly damaged (Figure 6).

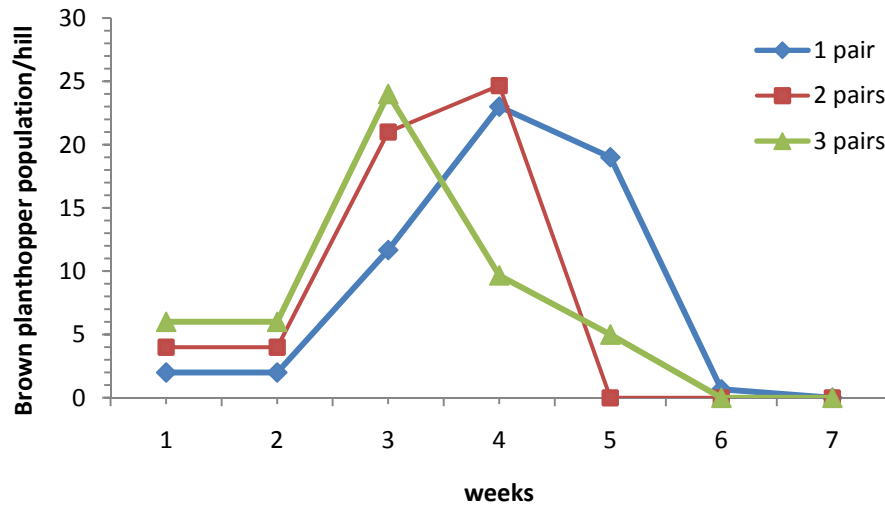

Figure 6. The population dynamic of brown planthopper on rice crop Cihorang variety, with initial population of 1, 2, and 3 pairs

The digital image parameter that has been successfully extracted from the data of leaf image for all treatments is Red, Green, dan Blue (RGB). The output of digital image processing is listed on Table 1.

Table 1. The parameter of digital image of rice leaf from a number of variations of nitrogen (N) sufficiency, pest attack, at the age of 1, 7, and 8 weeks

Treatment	No	Week 1			Week 7			Week 8		
		Red	Green	Blue	Red	Green	Blue	Red	Green	Blue
01-1-10 %	1	146	217	79	158	184	91	186	176	116
01-2-10%	2	121	199	87	102	165	34	125	136	111
01-3-10%	3	79	139	51	86	131	46	134	149	117
02-1-20%	4	129	185	88	129	139	111	130	142	88
02-2-20%	5	158	234	102	130	178	126	229	222	214
02-3-20%	6	80	134	38	189	196	156	165	175	129
03-1-30%	7	126	176	41	69	115	51	118	180	57
03-2-30%	8	151	219	80	106	165	57	154	194	119
03-3-30%	9	129	206	74	94	130	43	141	175	99
04-1-40%	10	149	214	70	71	132	52	112	152	86
04-2-40%	11	156	216	84	72	120	60	137	153	97
04-3-40%	12	113	181	68	90	131	63	134	149	95
05-1-50%	13	143	178	74	54	100	51	92	133	62
05-2-50%	14	138	185	81	99	171	107	92	134	58
05-3-50%	15	153	234	93	60	103	34	124	163	100
06-1-60%	16	86	132	33	62	120	59	108	145	74
06-2-60%	17	129	188	78	41	83	33	122	140	90
06-3-60%	18	134	222	60	135	185	116	124	150	90
07-1-70%	19	100	140	41	126	173	119	120	144	86
07-2-70%	20	154	196	84	137	178	120	148	153	105
07-3-70%	21	137	217	60	126	164	77	125	152	76
08-1-80%	22	153	244	104	71	131	61	176	187	116
08-2-80%	23	148	247	102	103	166	113	152	147	108
08-3-80%	24	150	242	104	81	124	53	120	141	98
09-1-90%	25	184	241	124	169	183	121	144	165	102
09-2-90%	26	154	240	120	86	152	90	122	140	94
09-3-90%	27	153	217	118	102	143	55	87	121	72
10-1-100%	28	141	223	95	114	176	79	101	118	48
10-2-100%	29	139	219	105	91	146	61	114	160	124
10-3-100%	30	153	223	95	76	127	52	131	185	110
11-1-110%	31	200	255	155	172	175	117	97	134	100
11-2-110%	32	160	225	97	159	176	110	103	154	111
11-3-110%	33	153	217	120	93	131	58	109	118	80
12-1-120%	34	157	217	97	140	148	83	80	127	62
12-2-120%	35	158	240	114	93	145	83	102	147	47
12-3-120%	36	153	237	97	102	143	75	122	162	101
13-1-130%	37	138	224	89	90	140	77	129	147	78
13-2-130%	38	124	176	68	177	181	112	129	147	78
13-3-130%	39	151	238	125	146	160	72	101	144	86
14-1-140%	40	68	115	35	106	125	52	127	175	76
14-2-140%	41	114	177	70	91	136	95	128	166	127
14-3-140%	42	100	166	56	121	167	105	124	153	78
15-1-150%	43	57	111	17	62	118	57	108	150	86
15-2-150%	44	95	167	57	73	124	67	83	125	58
15-3-150%	45	138	203	87	123	180	39	90	145	74
H1-1	61	81	121	33	133	117	104	152	127	97
H1-2	62	80	119	30	69	91	53	112	135	88
H1-3	63	75	110	75	152	123	105	206	193	159
H2-1	64	60	121	32	140	112	98	255	255	255
H2-2	65	79	121	30	165	129	105	236	218	204
H2-3	66	102	144	48	165	147	127	217	195	172
H3-1	67	94	140	32	126	109	93	210	191	148
H3-2	68	80	130	30	167	154	136	196	98	86
H3-3	69	94	118	32	161	145	130	232	218	183

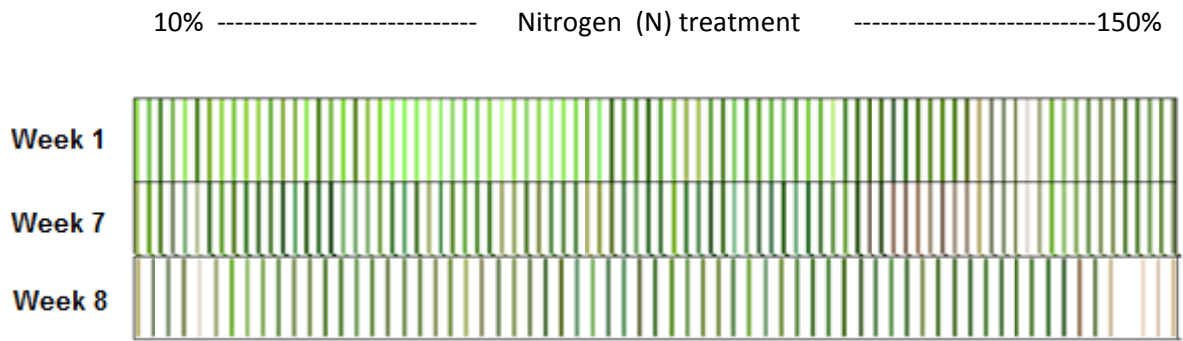

Figure 7. The color diversity of rice leaf on nitrogen (N) content treatments from 10% until 200%

CONCLUSION AND SUGGESTION

1. The variation of nitrogen content from 10% - 150% of recommended dosage produces various rice leaf color, amount of tiller, amount of panicles, and plant tissue weight.
2. The increase of nitrogen content from 10% - 200% causes color diversity from greenish yellow with the value of R: 86, G: 131, and B: 46, to dark green with the value of R: 119, G: 169, and B: 72.
3. The initial population of brown planthopper influences the population development. This rapid population increase is followed by rapid population decrease because of food source insufficiency from rice crop.
4. Rice leaf that is attacked by brown planthopper turns from green with the value of R: 206, G: 193, and B: 159 into brownish yellow with the value of R: 196, G: 98, and B: 86 along with the increase of brown planthopper population.

ACKNOWLEDGEMENT

The authors cordially thank to the Directorate of Research and Community Services (DITLITABMAS-DIKTI) for funding this research.

REFERENCES

- Ahmad, U. 2006. Pengolahan citra digital dan pemrogramannya. Graha Ilmu. Yogyakarta.
- Anonim, 2010. Standar Operasional Prosedur (SOP) Pengendalian Wereng Coklat dan Virus Kerdil. Informasi Ringkas Bank Pengetahuan Tanaman Pangan Indonesia. Balai Besar Penelitian Tanaman Padi.
- Blackmore, S. (1994). Precision Farming : an overview. *Agricultural Engineer* 49(3),86-88.

- Deptan RI, 2007. Peraturan Menteri Pertanian Nomor 40/Permentan/OT.140/04/2007 tentang Rekomendasi Pemupukan N, P, dan K Pada Padi Sawah Spesifik Lokasi. <http://www.litbang.deptan.go.id/regulasi/one/11/file/Revisi-Permentan-no-40.pdf>. diakses 2 Mei 2012.
- Dibike, Y.B., and D.P.Solomatine. 1999. River Flow Forecasting Using Artificial Neural Networks. <http://www.ihe.nl/hi/sol/papers/EGS99-annriverflow.pdf>
- Fu, L.M. 1994. Neural Network in Computer Intelligence. McGraw-Hill, Inc. New York. 459p
- Hermantoro, 2011. Prediksi Kadar Bahan Organik Tanah dengan Pengolahan Citra dan Jaringan Syaraf Tiruan Menggunakan Telepon Genggam. Prosiding Seminar Nasional Informatika Pertanian 2011 “Akselerasi Pengembangan Informatika Pertanian untuk Pemberdayaan dan Perlindungan Petani”.
- Munir & Rinaldi. 2004. Pengolahan Citra Digital. Informatika Bandung. Bandung.
- Paola, J. D. & Schowengerdt, R. A., 1995. A detailed comparison of neural network and maximum likelihood classifiers for urban land use classification, *IEEE Trans. Geosci. Remote Sensing* 33 (4), 981-996.
- Pham, D.T. 1994. Neural Network for Chemical Engineers. Elsevier Press. Amsterdam.
- Pujiharti, Y., J. Barus, dan B. Wijayanto. 2008. Teknologi Budidaya Padi. Seri buku inovasi: TP/01/2008. Balai Besar Pengkajian dan Pengembangan Teknologi Pertanian. Badan Penelitian dan Pengembangan Pertanian RI. 30hal.
- Srinivasan, A. (2006). Precision Agriculture: An Overview. In A. Srinivasan (Ed.), *Handbook of Precision Agriculture: Principles and Applications* (pp. 3-18). New York: The Haworth Press Inc.
- Suyamto, 2010. Strategi dan Implementasi Pemupukan Rasional Spesifik Lokasi. *Pengembangan Inovasi Pertanian*, 3(4), 306-318
- Toth, E., & Brath, H. 2002. Flood Forecasting Using Artificial Neural Networks in Black-Box and Conceptual Rainfall-Runoff Modelling. [Http://www.iemss.org/iemss2002/proceedings/pdf/-volume%20ue/370_toth.pdf](http://www.iemss.org/iemss2002/proceedings/pdf/-volume%20ue/370_toth.pdf)
- Tri, Y., 2012. Pemberdayaan Petani melalui Denfarm Padi. *Sinar Tani Edisi* 22-28 Februari, No. 3445, Tahun XLII.
- Virgawati, S., S. Sumarsih, F.R. Kodong, D. Nuryadin, E. Murdiyanto, H. Lukito, & W. Choiriyati, 2010. Pusat Kegiatan Belajar Masyarakat (PKBM) Sebagai Media Penerapan Teknologi Precision Farming dengan Decision Support System untuk Optimalisasi Pengelolaan Tanaman Pangan Ramah Lingkungan. Laporan Akhir Hibah Penelitian ESD DP2M Dikti.
- Yoshida S, Forno DA, Cock JH, Gomez KA, 1976. Laboratory Manual for Physiological Study of Rice. IRRI. Los Banos. The Phillipines. 83p.

PRODUCTIVITY, SOIL FERTILITY, AND ECONOMIC BENEFIT IN CHANGES FROM CONVENTIONAL TO ORGANIC RICE FARMING SYSTEM AT SRAGEN DISTRICT

Oktavia Sarhesti Padmini

Agrotechnology, Fac. of Agriculture UPN "Veteran" Yogyakarta

oktaviasarhesti@yahoo.com

ABSTRACT

Organic farming/products are becoming necessary in the world to control ecosystem health and to impart related human health benefits. The objective of this research was to increase production, improve soil chemical and physical properties and revenue and B/C ratio. The experiment was conducted at two sub-districts namely Ngrampal and Kobonromo, Sragen district, from November 2012 until March 2013. These sites represented three rice farming systems: conventional, semi organic and fully organic rice farming. Several investigation methods were applied, namely survey, and direct interview in the field; visit and discuss with farmers house. The fully organic system in Ngrampal and Kebonromo produced the lowest un-productive tillers, the highest percent-recovery and the same weight of rice. The fully organic and semi-organic farming systems increase chemical such as organic matter and cation exchange capacity, better selling price and income compared with conventional, although the three farming systems have the benefit of farming and constantly viable. Be caused it has a value of B/C ratio and R/C ratio more than one.

Keywords: Organic farming, Rice farming, soil fertilities, and economic analysis

INTRODUCTION

Increasing food production through green revolution is inseparable from the use of modern technologies such as improved seeds, chemical fertilizers, pesticides, and herbicides. Conventional rice farming is only oriented to increase rice yield by encouraging on using inorganic fertilizer and pesticide and refused using organic ones. Heavy reliance on chemical fertilizers as nutrient sources potentially reduce soil productivity, and soil compaction. Both of them will reduce organic matter. The most real effect was the plant gradually unresponsive on fertilizing (Gunadi and Bostang, 1997). Though the dosage of fertilizer had been increased, plant productivity was not in balance with supplying additional fertilize (Padmini, 2007; Deore *et al.*, 2010). Dependence on high doses of chemical fertilizers and pesticides as well as potentially reduce the land productivity, and also caused leveling productivity. Rice productivity in Sragen 2005-2011 respectively 5,558 tons / ha, 5.184 tons / ha, 5.367 tons / ha, 5.267 tons / ha, 5.318 tons / ha 5.668 tons / ha and 5.812 tons / ha. (Department of Agriculture and Food Security Sragen, 2011).

Department of Agriculture was making inroads Sragen use organic fertilizer that was triggered by movement healthy lifestyle that focuses on the importance of the foundation of life by "slogan Back to nature with vision Sragen Go Organic 2010" (Wiyono, 2007). Supported by the Ministry of Agriculture who agree that action must be performed, one of which increase agricultural production and maintain natural resources. In 2007 rice production increased 4.96% (Apriyantono, 2007). The basic principle of organic farming is the maintenance of good soil and following the philosophy that nature farming is how to give the soil life (Kosit, 2011). The aim of organic farming systems is improved agro-ecosystems healthy, biodiversity and biological activity (Dubey and Dubey, 2010).

Actually organic and semi-organic rice farming is profitable for farmers, this is due to organic rice production cost is lower and has a higher economic value than inorganic farming. The price organic rice in the market reached 9.000 IDR each kg, less than the price inorganic rice 8000 IDR each kg (Interviews with farmers, 2011). Organic farming technology can be used as an alternative to reduce the dependence on inorganic fertilizers and pesticides. Organic farming emphasizes the use of organic fertilizers and pesticides that do not harm the soil, so that the farmland ecosystem in balance (Sukristiyonubowo, *et al.*, 2011)

The farmers used to apply fertilizer N. P and K three times and the last application is conducted on three-weeks-old plants. At this time plants are still at the early tillering stage. Applying nutrient through the leaves to the next growth phase is very important. Organic fertilizers are applied through the leaves is more effective because it can be absorbed directly by the plant. Application organic liquid fertilizer combined with inorganic fertilizer provides better nutrient sufficiency. Based on the above problems will be very interesting to do research about productivity, soil fertility and Socioeconomic through changes from inorganic to organic rice farming systems in Sragen District.

MATERIALS AND METHODS

The experiment was conducted at two sub-districts namely Ngrampal and Kobonromo, Sragen district, Central Java in two cropping seasons: the rainy season (MH) I November 2012-March 2013. Assessment at the rice farming systems were done with Participatory Rural Appraisal. Number of farmer cooperators from Bener and Kebonromo villages for each of farming system five people. Land area studied between 0.5-2 hectares. To complete data on production and socio-economic evaluation conducted in several investigation methods were applied, namely survey, and direct interview in the field, visit and discuss with farmers house. and coordination with local authorities (village chief)

The three rice farming systems (conventional, semi-organic and fully organic) were mainly separated according to the labour cost and agricultural input cost. The labour cost consist of land preparation, planting, fertilization, weeding, pest and diseases control, watering and harvest. Agricultural cost consist of mineral fertilizers, powder organic fertilizer, LOF, Bio pesticides, Commercial pesticides, and 'Score'. The conventional systems, the farmers applied NPK (450 kg urea/ha+300 kg SP-36/ha+150 kg/ha KCl) and commercial pesticides. The semi organic system only less NPK fertilizers (150 kg urea/ha+100 kg SP-

36/ha and 75 kg/ha KCl) + 2 tons/ha organic fertilizers. The fully organic farming system, the farmer used 3 tons/ha organic fertilizers and liquid organic fertilizers (LOF “Plus” and Bacteria fertilizer). The LOF “Plus” was prepared in our field using agricultural waste (rotting/over ripened fruits and vegetables, and neem leaves extract enriched with rice sprout. The bacteria fertilizer contains 1) major microbes as providers of N, P, K elements through biosynthetic, bio enzymatic and fixation so they are available to plants; 2) secondary microbes that produce a food source for the proliferation of all microbes in the biotic associations; 3) and create ideal soil conditions for development of all microbes (Ngrembakatingkir.blogspot.com, 2011). The three kinds of farming systems used the source of water original from irrigation water.

In the farming system, we gathered data of production and economic to evaluate benefit cost (B/C ratio). The B/C ratio is calculated to the formula below (Sukristiyonubowo, *et al.*, 2011)

$$\frac{B}{C} \text{ ratio} = \frac{\text{Benefit}}{\text{Production cast}}$$

Production cost is sum of the labour and agricultural input cost, while Benefit is the different between the revenue and the production cost. When the B/C ratio is ≥ 1 , the rice farming systems is efficient and gives more benefit. In contrast when the B/C ratio ≤ 1 , the system farming is not efficient.

Observation about soil fertility by taking soil samples were done in three rice farming systems. Composited samples of top soil, 0-20 cm layers, were taken in November 2012 before starting experiment and March 2013 after experiment. These soil samples were analyzed in Analytical laboratory of the soil science at Faculty of Agricultural UPN “Veteran” Yogyakarta. Determining chemical included the measurement of pH (H₂O), was measured in 1:5 soil water suspension using a glass electrode method; Cation Exchange Capacity (CEC), Organic matter (Organic Carbon was determined by using the Walkley and total Nitrogen by using Kjeldahl), Phosphorus (available P) were measured colorimetric using Olsen methods.

RESULTS AND DISCUSSION

Observation to the yield components, included the number of tillers, number of panicles, length of panicles, number of grain per panicles. Also observations to the un-productive tillers, weight of grains per hill and per hectare, and percent-recovery (Table 1 and 2). The result showed that the number of tillers and panicles on the conventional and semi-organic systems from both of Kebonromo and Ngrampal villages were not different, but both of them were higher than fully organic system.

Table 1. The yield components for three differences rice farming system in the Sragen District, Indonesia for the wet season 2013

Village	Treatmens	Yield components			
		Number of tillers	Number of panicles	Length of panicles (cm)	Number of grain/panicles
Kebonromo	Conventional	22,67 a	18,33 a	24,67 b	103,67 c
	Semi organic	21,33 a	18,33 a	26,70 a	114,67 b
	Fully organic	16,33 b	15,67 b	25,17 ab	117,00 b
Ngrampal	Conventional	23,50 a	18,83 a	23,17 b	117,00 b
	Semi organic	23,33 a	19,83 a	27,33 a	127,67 a
	Fully organic	17,45 b	15,33 b	25,67 ab	124,25 a

Source : Data were gathered in the wet season 2013 with PRA methods and interviewed

The conventional and semi organic farming system in both villages have a higher yield but the conventional system produced the biggest percent-un productive tillers, the shortest length of panicles, the lowest number of grain/panicles and the smallest percent-recovery. The fully organic system produced the smallest un-productive tillers, the highest percent-recovery and the same weight of rice with the semi-organic system.

Table 2. The yield components for three differences rice farming system in the Sragen District, Indonesia for the wet season 2013

Village	Treatmens	Yield components				
		Un-productive Tillers %	Weight of grains per hill (kg)	Weight of grains/ha (ton)	Recovery (%)	Weight of rice
Ngrampal	Conventional	19,14 a	34,15 ab	7,28 a	61.07 b	4.45 a
	Semi organic	14,06 b	36,75 a	7,37 a	62.95 b	4.64 a
	Fully organic	10,17 c	33,23 b	6,52 b	64.97 a	4.24 a
Kebonromo	Conventional	19,63 a	34,75 ab	7,27 a	61.78 b	4.49 a
	Semi organic	15,29 b	37,00 a	7,10 a	62.20 b	4.42 a
	Fully organic	12,85 c	33,45 b	6,53 b	64.81 a	4.23 a

Source : Data were gathered in the wet season 2013 with PRA methods and interviewed

Observation to the Soil chemical and physical properties from three rice farming systems in sub district of Sragen Districts presented in the table 3. Application soil having a pH (H₂O) 6.64 and pH (KCl) 5.99. The pH is included in rather acid . Soil analysis results by conventional in both villages Ngrampal and Kebonromo have a pH (H₂O) 6,11 and 6,01. Content of organic matter was very low was 0,79 % and 0,76 %, Cation Exchange Capacity (CEC) was 12,63 me% and 10,84 me%. Content of total-N 0.09 % and 1,02 %. Levels of P-available was 85,15 ppm and 46,82 ppm. Application of organic fertilizer 3 tons.ha⁻¹. Season⁻¹ both in semi organic and fully organic can increase soil fertility, especially soil pH, C-organic, CEC and deeper, whereas reduce in P-available.

Table 3. Soil chemical properties from three rice farming systems in sub district of Sragen Districts (Soil were sampled in the wet season 2013)

Soil Parameters	Conventional		Semi organic		Fully organic	
	Ngrampal	Kebonromo	Ngrampal	Kebonromo	Ngrampal	Kebonromo
pH (H2O)	6,11	6,01	6,35	6,23	6,64	6,31
C (%)	0,79	0,76	0,85	0,85	1,71	0,18
N-total (%)	0,09	1,12	1,02	1,21	1,05	1,12
P Olsen (ppm P2O5)	85,15	46,82	58,27	41,26	36,70	20,49
CEC (me%)	12,63	10,84	13,43	15,42	19,46	17,79
Soil depth (cm)	17,50	15.50	30.00	28.50	33,50	30.00

Source : Analytical laboratory of the soil science at Faculty of Agricultural UPN “Veteran” Yogyakarta.

Economic analysis for three differences rice farming system presented in the table 4. The calculation of the efficiency and benefit farming showed that the fully organic and semi

Table 4. Simple economic analysis for three differences rice farming system in the Sragen District, Indonesia for the wet season 2013 (in IDR) per hectare

Parameters	Conventional		Semi organic		Fully organic	
	Ngrampal	Kebonromo	Ngrampal	Kebonromo	Ngrampal	Kebonromo
Production Cost						
Land leases	6,500,000	6,500,000	6,500,000	6,500,000	6,500,000	6,500,000
A. Labor cost:						
Land preparation	1,500,000	1,800,000	1,500,000	1,800,000	1,500,000	1,800,000
Planting	1,575,000	1,800,000	1,800,000	2,025,000	1,800,000	2,025,000
Fertilization	540,000	540,000	300,000	300,000	180,000	180,000
Weeding	900,000	900,000	600,000	600,000	500,000	500,000
Pest and diseases control	600,000	600,000	150,000	150,000	100,000	100,000
Watering	120,000	150,000	120,000	150,000	120,000	150,000
Harvest	1,800,000	1,950,000	1,800,000	1,950,000	1,800,000	1,950,000
B. Agricultural input cost:						
Mineral fertilizers	2,250,000	2,250,000	175,000	175,000	-	-
Organic fertilizer	-	-	300,000	300,000	300,000	300,000
LOF	-	-	-	-	-	-
Commercial pesticides	150,000	150,000				
‘Scorr’	150,000	150,000	-	-	-	-
Total Cost	16,085,000	16,790,000	13,245,000	13,950,000	12,800,000	13,505,000
Revenue	35,556,800	36,115,200	39,466,350	37,485,000	38,389,760	38,448,640
Benefit	19,471,800	19,325,200	26,221,350	23,535,000	25,589,760	24,943,640
R/C ratio	2.21	2.15	2.97	2.68	2.99	2.85
B/C ratio	1.21	1.15	1.98	1.69	2.00	1.85

organic rice in Ngrampal villages had more efficiency and benefit with the value of R / C ratio 2.99 and 2.97, and B / C ratio 2:00 and 1.98 respectively, followed by the fully organic and semi organic rice in Kebonromo villages with the R / C ratio 2.85 and 2.68, and B / C ratio 1.85 and 1.69 respectively. The lowest efficiency and benefit farming value found in conventional rice farming.

Soil fertility in research area were dominated by conditions very low, so the soil was categorized less fertile. The semi-organic and fully organic rice farming increase of the soil dept and chemical soil properties, especially increase the organic matter content, CEC, whereas reduce P-available. Organic matter as an indicator in determining soil fertility. Increased in organic matter correlated with increased cation exchange capacity. Formation of organic matter helps soil particles aggregation that can create a system that both air and water, thereby increasing the population of microorganisms in the soil. Nitrogen and phosphate in soil following with the organic matter content. If the levels of $N > 2.6\%$ and $C / N < 15/1$ it will take the mineralization process, resulting in the release of N. Instead immobilization occurs when the levels of $N < 1.2\%$ and $C / N > 33/1$. Microorganisms utilize nitrogen to proliferate, resulting in competition between plants to microorganisms (Anonim, 2005).

The fully organic system technology produced the smallest un-productive tillers, the highest percent- recovery and the same weight of rice. Although the conventional and semi organic farming system have a higher yield but the conventional system produced the biggest percent-un productive tillers, the shortest length of panicles, the lowest number of grain/panicles and the smallest percent- recovery. The role of organic fertilizer in semi organic systems can substitute NPK fertilizer, respectively 60 % urea, 60 % SP-36, and 50 % KCl for improving the highest yield.

The economic analysis in this study is empirical and is conducting comparative analysis between three treatments, i.e. treatment with three rice farming systems (conventional, semi-organic and fully organic). Table 6 shows that both treatments are financially efficient and profitable to manage. The criterions used for analyzing are Revenue Cost Ration (R/C) and Benefit Cost Ratio (B/C). The difference in input usage affects the cost of the productivity of the land (Gittinger, 2008). The conventional system technology costs more than the reduced one. In market, the price of NPK (inorganic fertilizers) is higher than the organic fertilizer, because the inorganic fertilizer is produced by factories (Purcell, 2009). On the other hand, the organic rice gets higher price than the rice produced by conventional farming using inorganic fertilizer. The price rice in Sragen Regency, Rp. 8000/kg (conventional rice), Rp. 8500/kg (rice semi organic) and Rp. 9000,-/kg (rice fully organic). It makes that the R/C and B/C of rice cultivation with the semi and fully organic systems were higher than conventional system.

In the recent years, the consumers' preference for healthy food tends to increase. They select healthy and delicious food including organic rice. In this condition the higher price of food including rice (organic/semi organic) becomes negligible. As shown in Table 7, R/C and B/C of rice by fully and semi organic were higher than conventional. Be caused the selling price of that rice were higher than conventional system, while organic fertilizer was

still cheap. Therefore, economically, rice produced with semi and fully organic ware very profitable.

CONCLUSION

The fully organic system in Ngrampal and Kebonromo produced the lowest un-productive tillers, the highest percent-recovery and the same weight of rice. The fully organic and semi-organic farming systems increase chemical such as organic matter and cation exchange capacity, better selling price and income compared with conventional, although the three farming systems have the benefit of farming and constantly viable. Be caused it has a value of B/C ratio and R/C ratio more than one.

REFERENCES

- Apriyanto, A. 2009. Rekor Baru dari Petani Indonesia oleh Webmaster. Pengabdian kepada Rakyat Indonesia. Arsip jurnal.
- Anonim, 2005. Handout chemistry and soil fertility. Gadjah Mada University Department of Agriculture and Food Security Sragen, 2011. Annual Reports Agricultural Office. Sragen Regency, Indonesia
- Deore, G. B., Limaye A. S., Shinde B. M., and S. L. Laware. 2010. Effect of Novel Organic Liquid Fertilizer on Growth and Yield in Chilli (*Capsicum annum*, L.). Asian J. Exp. Biol. Sci. Spl. 2010 :15-19
- Gunadi, D. H., dan B. Radjagukguk, 1997. (Terjemahan). Teknologi dan Penggunaan Pupuk. Gadjah Mada Univ. Press.
- Gittinger, J.P, 2008. Agriculture Economical Project Analysis. Universitas Indonesia Collaboration with Johns Hopkins, 579p
- Kosit, P. 2011. Kyusei Nature Farming and the adaptation of farmers in the Isan Region of Thailand. European Journal of Social Science 21 (3): 471-482.
- Ngrembakatingkir.blogspot.com. 2011. Revolusi Petani Indonesia Komuditas Tani Mandiri Indonesia
- Padmini, O.S. Tohari, D, Prajitno, dan A. Syukur. 2007. Peran Pupuk Organik terhadap Perbaikan Sifat Kimia Tanah dan Hasil Padi Sawah di Vertisol. Prosiding HITI (Buku 3). Solusi Miskekola Tanah dan Air untuk Memaksimalkan Kesejahteraan Rakyat. pp 1514-1523
- Padmini, O. S. 2010. Peran Pupuk Organik dalam Rotasi Tanaman Berbasis Padi Berkelanjutan Mendukung Ketahanan Pangan Nasional, Prosiding, Yogyakarta, 2 Desember 2010
- Purcell, W. D. 2009. Agricultural Marketing: System, Coordination, Cash and Future Price. Reston Publishing Company Inc. A Prentice Hall Company. Reston. Virginia, 472.

Sukristiyonubowo, R., Wiwik, H., Sofyan A, Benito, H. P., De Neve, S. 2011. Change from conventional to organic rice farming system: biophysical and socioeconomic reasons. *International Research Journal of Agricultural Science and soil Science* 1 (5): 172-182
Wiyono, 2007

UTILIZATION OF VISIBLE-NEAR INFRARED REAL-TIME SOIL SENSOR AS A PRACTICAL TOOL FOR PRECISION CARBON FARMING PRACTICE

B. S. N. Aliah^{1,4,*}, S. Shibusawa², M. Kodaira², R. Kanda³

¹United Graduate School of Agricultural Science, Tokyo University of Agriculture and Technology, 3-5-8 Saiwai-cho, Fuchu-shi, Tokyo, 183-8509, Japan.

²Institute of Agriculture, Tokyo University of Agriculture and Technology, 3-5-8 Saiwai-cho, Fuchu-shi, Tokyo, 183-8509, Japan.

³Graduate School of Agriculture, Tokyo University of Agriculture and Technology, 3-5-8 Saiwai-cho, Fuchu-shi, Tokyo, 183-8509, Japan

⁴Mechanization and Automation Research Centre, Malaysian Agricultural Research and Development Institute (MARDI), 43400 Serdang, Selangor, Malaysia

* Corresponding author: aliah@mardi.gov.my

ABSTRACT

This paper described the potential of utilizing a visible-near infrared (Vis-NIR) soil sensor to assess the variability in soil carbon, nitrogen and organic matter (SOM) for the purpose of carbon farming practice. In this study, soil reflectance spectra were acquired at depths of 10, 15 and 20 cm, and twenty soil samples were also collected for references at each depth, along the real-time soil sensor's (RTSS) tracks. Calibration model was then developed using partial least square regression (PLSR) technique coupled with full cross-validation as to establish the relationship between the soil reflectance spectra with the reference values of TC, TN and SOM obtained by chemical analysis. From the PLSR analysis, result shows that the accuracy of the developed model is classified as excellent for all the three soil properties with $R_{val}^2 = 0.87$, $RPD = 2.75$ for TC, $R_{val}^2 = 0.85$, $RPD = 2.58$ for TN and $R_{val}^2 = 0.82$, $RPD = 2.31$ for SOM. These three models were then used to provide quantitative prediction and mapping of soil TC, TN and SOM at 3 different depths respectively. From the generated maps, the variation in distribution of TC, TN and SOM at different depths can be clearly observed. From this study, it was found that the Vis-NIR has great potential for providing the C, N and SOM information needed for C sequestration studies towards mitigation of greenhouse-gases.

Keywords: *real-time soil sensor, carbon sequestration, total carbon, total nitrogen, soil organic matter*

INTRODUCTION

The global warming issue as a consequence of rising atmospheric CO₂ concentrations has focused the attention of researchers to tackle this problem through improving farm management. For this purpose, carbon farming with the adoption of precision agriculture approach has been introduced to reduce atmospheric carbon by increasing

the amount of carbon stored in the soil. This is also known as carbon sequestration. By storing carbon in the soil, farmers and landowners are able to earn carbon credits and at the same time reducing greenhouse gas emissions on the land. The carbon credits can then be sold to people and businesses wishing to offset their emissions (carbon trading). Due to the awareness on the benefits and advantages of carbon farming, many researchers are playing important role by undertaking various research to improve the effectiveness of carbon farming practice. In Japan, Li *et al* (2009) has investigated the potential of carbon farming in Japanese small-scale paddy through a case study of Japanese precision agriculture pioneer. In this study, it was found that the Japanese paddy fields are potential for carbon sequestration and feasible for carbon farming practice over time.

The emission of nitrous oxide resulted from excessive of nitrogen applied has made agriculture a significant contributor of another greenhouse emission. To overcome this issue, farmers should change nutrient management practices as to reduce emissions from nitrogen fertilizers and manure applied to farmers' fields. Practices that help farmers reduce nitrogen applications without reducing yields include precision application, use of slow-release fertilizers or nitrification inhibitors, and changes in application timing to better match plant uptake of nutrients (Smith *et al* 2008).

Any effort to increase the amount of carbon in the soil and improve nitrogen use efficiency requires information on carbon (C) and nitrogen (N) levels in the soil. This information, nevertheless, should not be limited to C and N stocks but should incorporate information of soil organic matter (SOM) because this soil property fixes carbon in the soil (Cecillon and Brun2010). However, the capacity to detect temporal changes of these properties in soil using conventional sampling and analysis techniques is quite limited due to the large spatial variability and slow response of these properties on land use conversion or change in soil management (Stevens *et al* 2006). Conventional method often resulted in under-sampling because of the time consuming, laborious and costly sampling and analysis. Therefore, an improved and efficient method is needed for measuring spatial and temporal of C, N and SOM. One solution to overcome the limitation existed in conventional method of soil sampling and analysis is by adoption of a visible-near infrared (Vis-NIR) sensor that is real-time, cost effective and can rapidly measure soil C, N and SOM. Kodaira and Shibusawa (2013) has successfully used Vis-NIR real-time soil sensor for measuring and mapping of multiple soil properties including total carbon, total nitrogen and SOM. In other study, Mouazen *et al*(2007) suggested the potential use of the Vis-NIR sensing system for online measurement of soil properties including carbon while Christy (2008) also demonstrated that the Vis-NIR real-time sensor has potential for mapping soil organic matter.

The quantification of soil C, N and SOM however, should not only consider at horizontal strata but also vertical strata. The vertical strata is found to be important because soil carbon is likely to vary with depth. Most soil carbon sampling thus defines one or more layers of soil, usually by the distance in centimetres from the soil surface (Donovan, 2012). Varying amount of SOM also found in depth as reported by Reeves *et al* (2002). There are several studies considered several depths which includes 10 to 20cm depths (Yang *et al* 2011), 0 to 20(Viscarra Rosselet *al*, (2010) and 50 to 105cm (Geet *al* 2011). The spectra measurements for calibration model development in these studies however were laboratory basis which is again laborious, time consuming and

expensive because the samples need to be crushed, sieved and dried prior to spectra scanning. Sarkhot *et al* (2011) used hydraulic soil probe take soil core and separated the soil core into 5 depths increment 0-10, 10-20, 20-30, 30-40, 40-50 cm where these soil were oven dried before spectra scanning in laboratory. The map representing respective depth was not shown. Thus, the objective of this study was to investigate the potential of Vis-NIR real-time soil sensor for mapping total carbon (TC), total nitrogen (TN) and soil organic matter (SOM) of paddy soil at multiple soil depths for precision carbon farming purpose. The spatial distribution of these three soil properties were observed at three depths of paddy soil which are at 10, 15 and 20cm.

MATERIALS AND METHOD

A. Experimental Site Description

The experimental site was at a commercial paddy field in Matsuyama City of Ehime Prefecture Japan (Fig.1). This site comprises of number of small paddy fields and field no. 437 (58.3m x 21.7m) was chosen for this study. The experiment was conducted after harvesting paddy in October 2012. The soil texture of the field is described according to three depths as follows: 52.82% sand, 24.71% silt and 22.47% clay at 10cm depth, 54.55% sand, 21.02% silt and 24.43% clay at 15cm depth, 66.29% sand, 11.82% silt and 21.89% clay at 20cm depth.

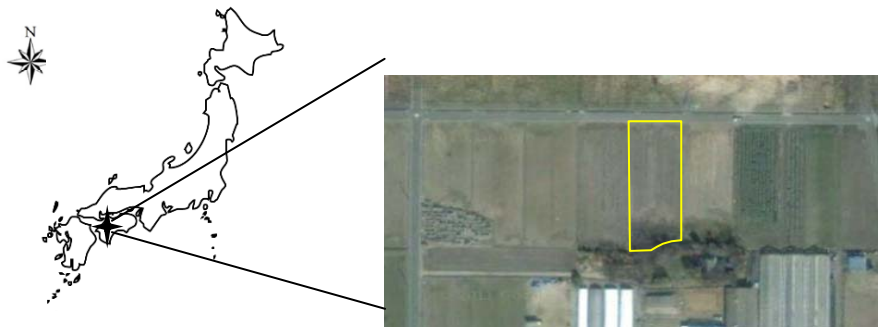

Figure 1. Location of the experimental site including the field no. 437 layout

B. Real-Time Soil Sensor (RTSS)

The RTSS used for this study was SAS1000, SHIBUYA MACHINERY Co., Ltd (Fig. 2). It comprises of sensor unit's housing, a touch panel, soil penetrator and the housing for the probes. The sensor unit's housing consists of a personal computer, differential global positioning system (DGPS) receiver, 150-W Al-coated tungsten halogen lamp as a light source and two spectrophotometers. The first spectrophotometer is for Vis (305 to 1100nm), has a 256-linear diode array while the second spectrophotometer is for NIR (950 to 1700nm), has a 128-pixel linear diode array of multiplexed InGaAs. In the probe housing, two optical fibres were used to guide the light from the light source (halogen lamp) and illuminate the underground soil surface with area of about 50mm in diameter. The underground soil Vis-NIR reflectance spectra were then collected through an additional optical fibre probes to the two spectrophotometers. The probe housing is also equipped with a micro CCD camera to capture, record and display the images of uniform soil surfaces while the RTSS running across the field. The saved images were

then used to detect outlier in the calibration and prediction process. In addition, a laser line marker located close to the optical fibre was used to monitor distance variations between the soil surface and the micro optical devices.

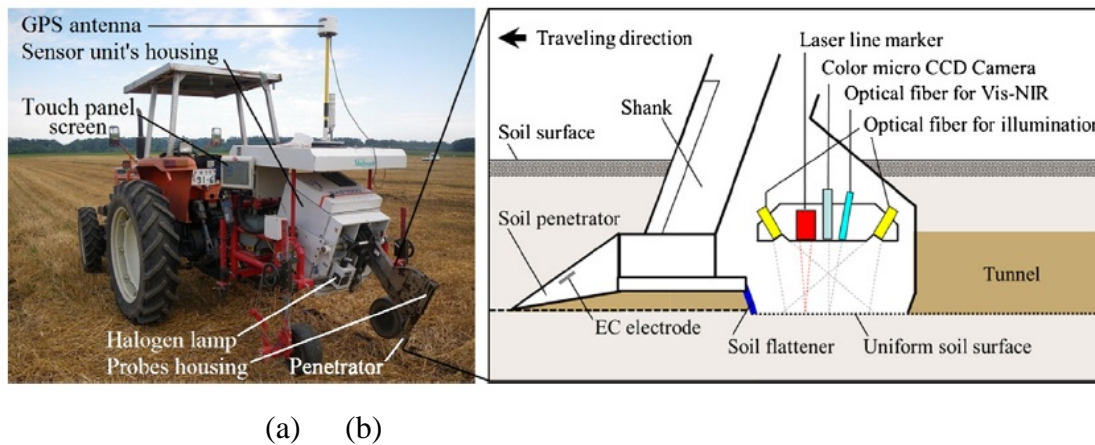

Figure 2. Real-time Soil Sensor SAS1000 attached on tractor (a) and probe housing schematic diagram (b).

C. Collection of Vis-NIR Spectra using the RTSS and Soil Samples

In this experiment, the depth was initially set to 10cm by adjusting the gage wheel (Fig. 3). The tractor attached with the RTSS was then travelled on 4 transects of 5m spacing at the speed of 0.25ms^{-1} . When the RTSS running on the track, the soil penetrator tip with a flat plane edge ensured uniform soil cuts and the soil flattener following behind formed a trench with a uniform underground surface. The underground soil Vis-NIR reflectance spectra data were acquired automatically from the bottom of the trench at every 4 s and this resulted on the Vis-NIR reflectance spectra been sampled at interval of approximately 1 m. After the RTSS has completely travelled for all the 4 transects, the processes were repeated for 15 and 20 cm depth.



Figure 3. The gage wheel on both sides of RTSS can be adjusted of 5 cm spacing to collect soil spectra at the depth of 5cm to 35 cm from the topsoil.

While the RTSS running on the track, alarms were triggered at each data acquisition (every 1m travelled). The number of data were counted and displayed on the touch panel screen. When the RTSS acquired every 11th spectra data (11m), a wooden stick was inserted into the soil. Twenty soil samples were subsequently collected at the trench bottom of the wooden sticks positions and packed them in sealable plastic bag. This procedure was carried out for every 10, 15 and 20cm depths and resulted in 59 number of soil samples collected (one sampling point at 20cm depth was omitted due to the RTSS travelling obstacle). Chemical analyses were then performed on these samples at

the laboratory to determine the amount of TC, TN and SOM. The soil samples were analysed using NC-220F, SUMIGRAPH soil analyser according to Tyurin's method for TC, Kjeldahl method for TN and combustion ignition method for SOM.

D. Development of Calibration Model and Mapping

Prior to the development of calibration models, all collected underground Vis-NIR soil reflectance spectra were converted to absorbance using the Beer-Lambert's Law. The absorbance spectra were then pre-treated using second derivative Savitzky and Golay method and the calibration models were subsequently developed. These were done in the Unscrambler X10.2 software. Calibration models were developed using partial least square regression (PLSR) technique coupled with full-cross validation as to establish the relationship between the pre-treated Vis-NIR soil absorbance spectra with the value of soil properties obtained by chemical analysis (lab-measured values). The performance of the three calibration models were assessed based on the value of coefficient of determination (R_{val}^2), root means square error of prediction ($RMSE_{val}$) and residual prediction deviation (RPD) produced from the PLSR analysis. The calibration models were then used to provide quantitative prediction and mapping of soil TC and TN using Arc GIS Ver10.0 software.

RESULTS AND DISCUSSIONS

Table 1 shows the PLSR analysis result of calibration model for TC, TN and SOM. According to Chang *et al.* (2001), RPD values more than 2 were considered excellent, between 1.4 and 2 were almost good and below 1.4 were unreliable. From this classification, it was found that the performance of the developed model for predicting TC, TN and SOM are excellent. The scatter plot of the model for TC, TN and SOM are depicted in Fig 4.

The unknown soil spectra were predicted using developed calibration models for all the three depths. The prediction values for all the depths of TC, TN and SOM were mapped as illustrated in Fig. 5. From these maps, it can be clearly seen that the distribution of TC, TN and SOM are not only horizontally variable but also varies in depths. The 10 cm depth shows higher concentration of TC, TN and SOM, and it is decreases at deeper soil depths.

Table 1.PLSR for TC, TN and SOM

SP	N	Calibration			Validation				
		R_{cal}	R_{cal}^2	$RMSE_{cal}$	R_{val}	R_{val}^2	$RMSE_{val}$	SD	RPD
TC	53	0.96	0.92	0.12	0.93	0.87	0.16	0.43	2.75
TN	53	0.96	0.92	0.01	0.92	0.85	0.01	0.03	2.58
SOM	53	0.91	0.84	0.25	0.90	0.82	0.27	0.62	2.31

SP: Soil Properties, N: number of sample, R_{cal} & R_{val} : Correlation coefficient, R_{cal}^2 & R_{val}^2 : Coefficient of determination, $RMSE_{cal}$ & $RMSE_{val}$: Root mean square error, SD : Standard Deviation of measured value, RPD : Residual Prediction Deviation

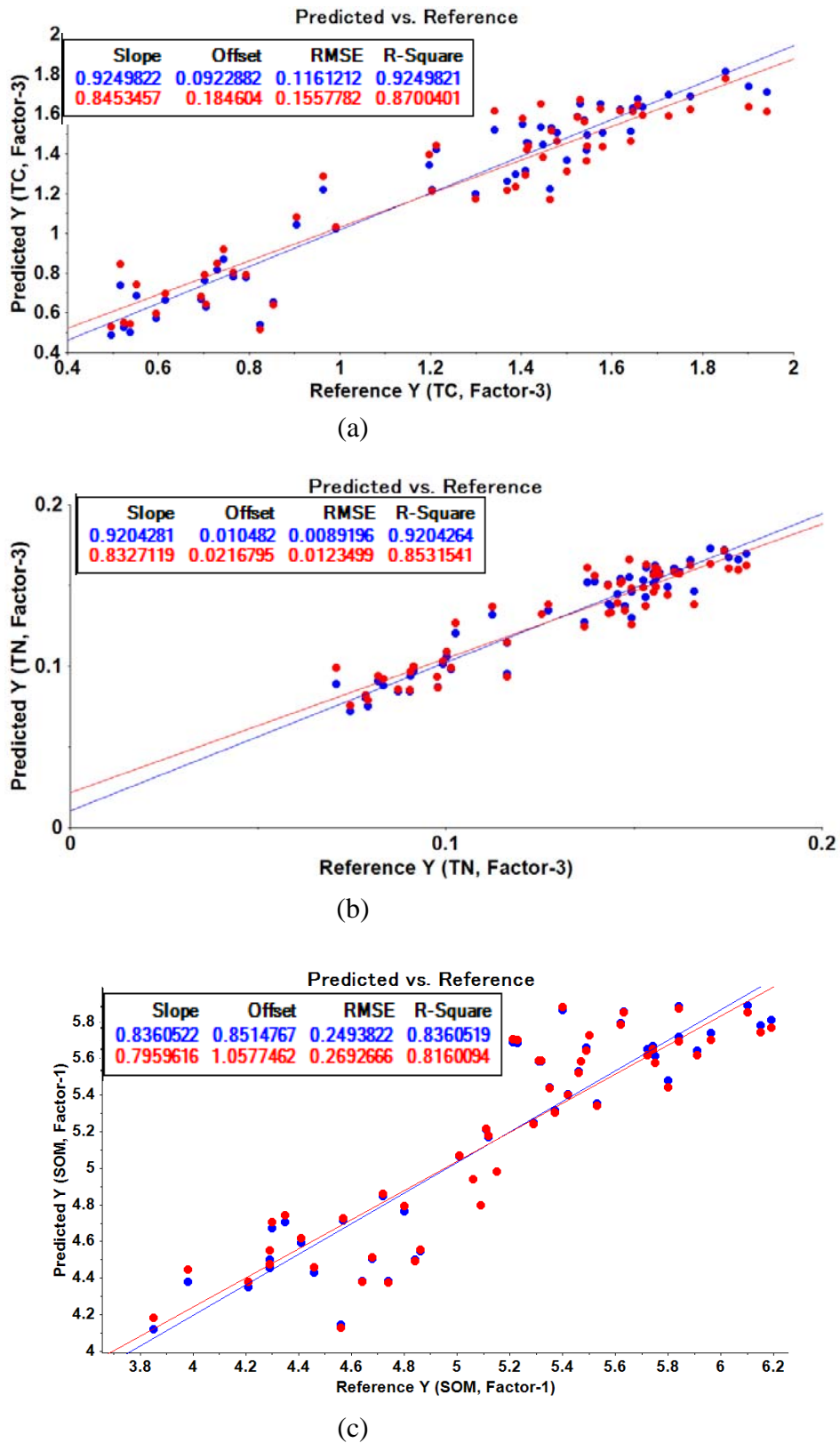

Figure 4. Scatter Plot for (a) TC, (b) TN and (c) SOM

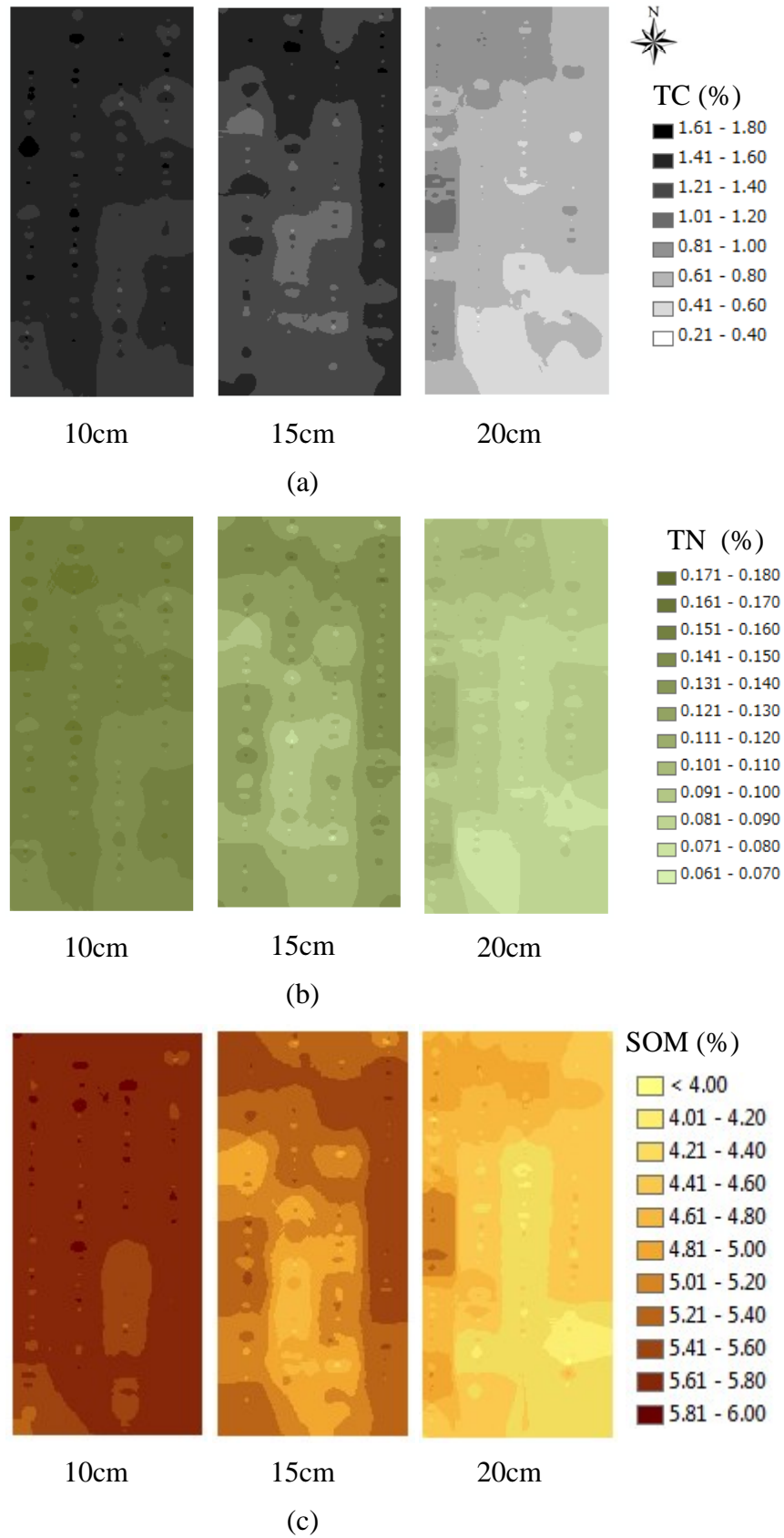

Figure 5. Three depths Maps for (a) TC, (b) TN and (c) SOM

CONCLUSION

From this study, the spatial distribution of TC, TN and SOM at different soil depths have been observed. From the generated maps, the variation in distribution of TC, TN and SOM at different depths can be clearly observed. This indicates that the spatial variability TC, TN and SOM not only varies at horizontal strata but also at vertical strata. Furthermore, the incorporation of multiple soil depths maps of TC, TN and SOM could provide comprehensive information. From this study, it can be concluded that the Vis-NIR real-time soil sensor has great potential for providing the C, N and SOM values needed for C sequestration studies towards mitigation of greenhouse-gases.

ACKNOWLEDGEMENT

We would like to express appreciation to Aguri Company, Matsuyama for allowing us to use their field and Shibuya Seiji Co., Ltd for their cooperation with operating the tractor. This appreciation also dedicates to the students of Environmental and Agriculture System Laboratory, Tokyo University of Agriculture and Technology for their important help with the extensive soil sampling.

REFERENCES

- Cecillon, L & Braun, JJ 2010, 'Near-infrared reflectance spectroscopy (NIRS): a practical tool for the assessment of soil carbon and nitrogen budget' *Greenhouse-gas Budget of Soils under Changing Climate and Land Use (BurnOut)*, COST 639 http://bfw.ac.at/010/pdf/Act_639/L-CECILLON.pdf
- Chang, CW, Laird, DA, Mausbach, MJ, Hurburgh Jr, CR 2001 'Near-infrared reflectance spectroscopy-principal components regression analysis of soil properties', *Soil Science Society of America Journal*, vol. 65, pp. 480–490.
- Christy, CD 2008 'Real-time measurement of soil attributes using on-the-go near infrared reflectance spectroscopy' *Computer and Electronics in Agriculture*, vol. 61, pp. 10 -19.
- Donovan, P, 2012, Measuring soil carbon change: a flexible, practical, local method, <http://soilcarboncoalition.org/files/MeasuringSoilCarbonChange.pdf>
- Ge, Y, Morgan, CLS, Grunwald, S, Brown, DJ & Sarkhot, DVS 2011, 'Comparison of soil reflectance spectra and calibration models obtained using multiple spectrometers', *Geoderma*, vol. 161, issues 3-4, pp. 202-211.
- Kodaira, M & Shibusawa, S 2013, 'Using a mobile real-time soil visible-near infrared sensor for high resolution soil property mapping' *Geoderma*, vol. 199, pp. 64-79
- Li, Y, Shibusawa, S, Kodaira, M, Oomori, T, Aliah BSN 2012, 'A scheme of precision carbon farming for paddy', *Proceeding of the 11th International Conference on Precision Agriculture*, International Society of Precision Agriculture, Indiana, USA, (proceeding in CD)
- Mouazen, AM, Maleki, MR, De Baerdemaeker, J & Ramon H 2007, 'On-line measurement of some selected soil properties using Vis-NIR sensor' *Soil & Tillage Research*, vol. 93, pp. 13-27.

- Sarkhot, DV, Grunwald, S, Ge, Y & Morgan CLS 2011, 'Comparison and detection of total and available soil carbon fractions using visible/near infrared diffuse reflectance spectroscopy' *Geoderma*, vol. 164, pp. 22-32.
- Smith, P, Martino, D, Cai, Z, Gwary, D, Janzen, H, Kumar, P, McCarl, B, Ogle, S, O'Mara, F, Rice, C, Scholes, B, Sirotenko, O, Howden, M, McAllister, T, Pan, G, Romanenkov, V, Schneider, U, Towprayoon, S, Wattenbach, M & Smith, J 2008, 'Greenhouse gas mitigation in agriculture' *Philosophical Transactions of the Royal Society B* 363: pp. 789-813.
- Stevens, A, Wesemael, BV, Vandenschrack, G, Toure, S & Tychon, B 2006 'Detection of carbon stock change in agricultural soils using spectroscopic techniques' *Soil Science Society of America Journal*, doi: 10.2136/sssaj2005.0025, Vol. 70 No. 3, pp. 844-850.
- ViscarraRossel, RA, Rizzo, R, Dematte, JAM & Behrens, T 2010 'Spatial modeling of a soil fertility index using visible-near-infrared spectra and terrain attributes', *Soil Science Society of American Journal*, vol.74, number 4, pp. 1293 –1300.
- Yang, H, Kuang, B & Mouazen, AM 2011, 'Prediction of soil TN and TC at a farm-scale using VIS=NIR spectroscopy' *Advanced Materials Research*, vol. 225-226, issues 1-2, pp. 1258-1261.

DESIGNING OF ERGONOMIC SOYBEAN GRINDER TO INCREASE INDUSTRY PRODUCTIVITY

(CASE STUDY ON HOME INDUSTRY OF “TEMPE” IN BANTUL, YOGYAKARTA)

Dyah Rachmawati Lucitasari^{1*}, Deny¹

¹ Department of Industrial Engineering, Faculty of Industrial Technology,
UPN “Veteran” Yogyakarta

* Corresponding author: dlucitasari@yahoo.co.id

ABSTRACT

Approximately 65 % workers of *tempe's* industry, primarily on soybean's grinding process, having pain on the joints of the body (hand , right shoulder, and leg) due to the work tool (grinders) that were still using human labour so that the workers work constantly rotate the tool . The purpose of this research was to design an ergonomic soybeans grinder so that workers were able to work safely and comfortably and the productivity would be improved. This study was conducted to design and to make an ergonomic soybeans grinding tool, for reducing fatigue on the joints of the worker body. Data processing was conducted by observing position, complaints on the joints of the body, anthropometry, and heart pulse data of the workers, before and after designing the tool. Based on anthropometric value, the ergonomics' grinding soybean machine should be designed on 87 cm height, 23 cm width, and 30 cm length. The designed machine was able to support the position of the operators more comfortable and safer. Expended energy and fatigue could be reduced and productivity would be improved 0.26, from 1.69 into 1.95.

Keywords: *Soybean grinding machine, Ergonomics, Productivity*

INTRODUCTION

Small industry is a potential industry to be developed. In district of Bantul, small industries such as *tempe-tofu's* industries, contributed substantial foreign exchange. Preliminary survey of the *tempe* industry labour, especially in soybean grinding section, the pain complaint in the joints of the labour's body approximately 65 %. The complaints include pain on the back, arm, right shoulder, and leg due to the use of ineffective and inefficient facilities. This was caused by the use of manual grinding machine. The worker works by continuously rotating grinding machine.

Designing and development of products are a part of the innovation process in the industry. Through designing and developing product, it is expected to generate product innovations that can provide certain advantages which are more effective and efficient.

Sutalaksana (1979), defines ergonomics as a systematic discipline to take advantage of information about the nature of human abilities and limitations to design a working

system so that people can live and work on the system properly. The desired goal is to achieve efficiency, effectiveness, safety and comfort. Tarwaka (2004) and Solichul (2004) stated that the general purposes of the application of ergonomics are: 1) Improve the well-being of physic and mental through the prevention of injuries and occupational disease, reduce mental and physical workload, seeking promotion and job satisfaction. 2) Increase social welfare by improving the quality of social contact, managing and coordinating the appropriate work and improving the social security during and after the period of reproductive age. 3) Creating a rational balance between the various aspects: technical, economics, and cultural anthropologist of any system of work in order to create a high quality of work and life. Central concern lies in human ergonomics in the design of man-made objects and facilities and environments used in various aspects of human life. The goal is to design the objects, facilities, and the environment, so the effectiveness and function can be increased, and humanitarian aspects such as health, safety, and satisfaction can be maintained.

The purpose of grinding is to separate the epidermis from the beans, as well as to break/cut the beans. Manually grind resulted in less amount product, takes much longer, and epidermis could not totally separate from the beans.

MATERIAL AND METHODS

The objects of research were the soybean grinder workers in *tempe*-tofu Company, located in Bantul, Yogyakarta. Workers worked using grinder manually for six hours per day. The primary data was obtained by direct observation and interviews on the workers (nordic body map data). The data were about age, duration of work, work attitude, body dimensions, and heart pulse before and after the study by using a new grinder machine, and a complaint that a worker felt in their body parts during grinding soybeans as well as matters relating to research. Secondary data required in this study was the percentage calculation of nordic body maps for workers.

Stages of data processing was carried out for the identification of ergonomic issues such as anthropometric data and then processed with a uniformity test. Also taken into account the energy expended during and after working, so the energy released by the operator to operate the soybeans grinding machine could be recorded. The next step was to calculate the productivity of the company before and after the design revision of the machine.

RESULT AND DISCUSSION

Detection on heart pulse of workers on unrevised design of grinding soybean machine, before and after working, indicated that the pulse was higher than those on revised design (Table 1). Higher manpower was needed to operate the machine. Exhausted will be experienced faster by the workers during their working period.

Based on ergonomic analysis, subjective complaints of soybean grinder workers decreased. With the appliance of revised design machine, company could implement ergonomic work tools in the work place. Subjective complaints on the right shoulder, back, right and left leg, lower arm and waist abdomen were reduced, resulting in the increase of healthful working conditions and produced grinded soybean faster and cleaner.

Based on tables 2 and 3, the energy consumption on unrevised design was higher than on revised design of grinding machine. It means that reduction of the worker's energy was occurred, so the total energy consumption after revised of design was reduced.

Table 1. Worker's heart pulse on unrevised design and revised design of soybean grinding machine

Samples of workers	Before working		After working	
	unrevised	revised	unrevised	revised
1	95	80	79	72
2	93	85	76	71
3	99	89	75	75
4	101	87	78	73
5	100	87	77	76
6	98	86	75	72
7	101	85	76	70
8	99	83	77	73
9	100	83	75	74
10	97	84	78	73
Mean	96.3	84.9	76.6	72.9
SD	2.744	2.693	1.424	1.792

Table 2. Energy consumption on unrevised design of soybean grinding machine

Samples of worker	On working	After working	Y on working (Kkal/mt)	Y after working (Kkal/mt)	Consumption (Kkal/mt)
1	95	79	3.88544	2.93421	0.951231
2	93	76	3.74774	2.78802	0.959716
3	99	75	4.15987	2.73969	1.420171
4	101	78	4.30275	2.84795	1.454799
5	100	77	4.23084	3.62610	0.604740
6	98	75	4.08302	2.73969	1.343322
7	101	76	4.30275	2.78802	1.514730
8	99	77	4.15987	3.62610	0.533770
9	100	75	4.23084	2.73969	1.491141
10	97	78	4.00467	2.84795	1.156719
				Mean	1.143034

Table 3. Energy consumption on revised design of soybean grinding machine

Samples of worker	On working	After working	Y on working (Kkal/mt)	Y after working (Kkal/mt)	Consumption (Kkal/mt)
1	80	72	2.98621	2.28663	0.6996
2	85	71	3.26026	2.19637	1.0639
3	89	75	3.96512	2.73969	1.2254

4	87	73	3.38186	2.37783	1.0040
5	87	76	3.38186	2.78802	0.5938
6	86	72	3.64913	2.28663	1.3625
7	85	70	3.26026	2.10706	1.1532
8	83	73	3.34162	2.37783	0.9634
9	83	74	3.34162	2.46997	0.8717
10	84	73	3.44319	2.37783	1.0654
Mean					1.0000

Based on anthropometric measures of forward grip reach to the machine before revised design was 50 cm long (Table 4). The average value of forward grip reach was 67.12 cm by using the 95th percentile. It means that the arm reach to the tool was 67.12 cm maximum, so if there were workers with short body could also use this tool easily and comfortably without any difficulties to reach. The height of revised design machine was 87 cm. That measure is based on workers elbow height with an average of 90 cm by using the 10th percentile. It means that this machine can be used for short worker that with standing elbow height less than 87-90 cm. It will more ergonomic for workers with higher body. While the high of unrevised design engine was 65 cm long. Width size of hopper inlet for delivering the bean to the machine was 8 cm, based on the average of hand width, using 10th percentiles. This means that by using the 10th percentile, the hopper size should be at least 8 cm. Workers will be comfortably and safely to work if the hopper size more than 8 cm. The dimension of revised design machine was adjusted to the size of worker's anthropometry. In addition of reducing the subjective complaint, it also reduced premature fatigue. Workers would be comfortable in the work and did not feel tired before their working time lasted, thus increasing the productivity.

Table 4. Antropometric data of soybean grinder workers (cm)

Samples of worker	Elbow height	Forward grip reach	Hand width
1	93	67	8.5
2	94	69	8.2
3	88	68.5	7.3
4	89	65.5	8.1
5	90	67	7.5
6	90	67.5	8.3
7	93	67	7.5
8	87	66.5	8
9	90	68.5	8.5
10	89	67	8.6
11	90	65.5	7.9
12	89	68	8.5
13	87	66	7.5
14	92	68	8.5
15	90	67.5	7.6
16	91	66.5	8.1
17	88	65	7.5
18	87	65	8.4
19	88	67	7.4

20	92	68.5	8.6
21	91	68	7.5
22	93	69.5	8.6
23	93	66	8
24	89	67.5	8.5
25	91	67	9
26	89	68.5	8.5
27	88	67.5	7.6
28	89	66.5	8.2
29	90	68	8.4
30	89	64.5	7.6

Labour productivity on soybean grinding activities is essential. This is a measure point of the success of the revised design machine. Increase in output was found in revised design machine appliance (Table 5). Productivity of soybean grinding machine before improvement was 1.69, whereas the improvement could increase productivity into 1.95. The machine increased 0.26 of productivity.

Table 5. Productivity on unrevised and revised design of soybean grinding machine

Criteria	Un revised design (Rp./month)	Revised design (Rp./month)
Output	29,120,000	98,280,000
Workers salary	2,600,000	1,300,000
Fuel cost	-	23,400
Material cost	14,560,000	49,140,000
Machine maintenance cost	-	50,000
Productivity	1.69	1.95

Overall, the differences of the unrevised design and the revised design of soybean grinding machine can be seen in Table 6.

Table 6. The difference of unrevised design and revised design of soybean grinding machine

Part of machine	Unrevised design	Revised design
Body	Height: 65 cm	Height: 87 cm
	Length: 23 cm	Length: 30 cm
	Width: 18 cm	Width: 23 cm
Hoper inlet	Height: 25 cm	Height: 30 cm
	Length: 20 cm	Length: 25 cm
	Width: 15 cm	Width: 21 cm
Hoper outlet	Height: 30 cm	Height: 34 cm
	Width: 18 cm	Width: 22 cm
Engine power	Manual	Electric motor

CONCLUSION

The revised design of the soybean grinder can support the operator position at work more comfortable and safer, so the early fatigue that is felt during working period and energy expenditure can be reduced due to the use of electric motor. Productivity can be increased 0.26, from 1.69 into 1.95.

REFERENCES

- Gasperz, Vincent, 2000, Manajemen Produktivitas Total Strategi Peningkatan Produktivitas Bisnis Global, Gramedia, Jakarta.
- Hadi,S. 1995. Metodologi Research. Jilid IV.Yogyakarta:Penerbit Andi Offset.
- Nurmianto, E., 1991. Ergonomi, Konsep Dasar dan Aplikasinya, PT. Guna Darma, Jakarta.
- Suma'mur, P.K. 1989. Ergonomi untuk Produktivitas Kerja. Jakarta : PT. Temprint
- Sutalaksana, I.Z., 1979. Teknik Tata Cara Kerja. Departemen Teknik Industri. Bandung.
- Tarwaka., B., Solichul, H.A., dan Sudiajeng, L., 2004. Ergonomi Untuk Keselamatan, Kesehatan Kerja dan Produktivitas, Surakarta: UNIBA PERS.
- Ulrich K.T., 2000, Product Design and Development. Mc Graw-Hill.
- Wignjosoebroto Sritomo, 1995, Ergonomi Studi Gerak Dan Waktu, Edisi Pertama, Surabaya, Guna Darma.

ORGANIC FARMING TECHNOLOGY USING GUANO FERTILIZER AND MULCH IN CULTIVATING STRING BEANS (*Phaseolus vulgaris* L)

Tutut Wirawati^{1*}, Endah Budi Irawati²

Agrotechnology, Faculty of Agriculture UPN "Veteran" Yogyakarta

Jl. SWK. 104 Condongcatur, Yogyakarta

* Corresponding author: tututwirawati@yahoo.com

ABSTRACT

Organic agriculture is one of the alternative agriculture for supporting the sustainable of land productivity. The research which intended to study and evaluate guano fertilizer and mulch to the yield of string bean plants, was done in Gambiran, Pakem, Sleman, Yogyakarta from July to September 2008. Experimental design used a Randomized Completely Block Design Factorial arranged in 3x3 with 3 replications and 1 control. The first factor is guano fertilizer dosage consisted of 150, 300, and 450kg/ha. The second factor is the types of mulch consisted of white plastic mulch, black-silver plastic mulch, and straw mulch. Control was basic fertilizing with NPK without guano fertilizer and mulch. Data collected were subjected to an analysis of variance followed by mean separation based on Duncan's Multiple Range Test 5%. The result of this research showed: Guano fertilizer at dosage 300 and 450 kg/ha has the same effect in increasing the plant height, growing the flowers faster, increasing the number of plants and increasing the weight of the seeds/ha up to 82.9%. Plastic mulch and black-silver plastic have the same benefit in decreasing the weeds (dry weight).

Keywords: *guano fertilizer, mulch, string bean*

INTRODUCTION

Bird droppings fertilizer or known as guano is a kind of droppings which from various kind of wild birds (not pets). Fertilizers which come from animal droppings are organic fertilizer usually used in organic-fertilizing. Organic fertilizer spurs and improves microbial population on the soil much bigger than just chemical fertilizer. The use of bird droppings is beneficial for preventing environmental damage, as well as improving plant production at the same time. It is a fact that bird droppings in quite a lot amount can be some cheap organic fertilizer. Bird droppings have high fertilizer value (solid and liquid) and easy to be decomposed.

The effect of animal droppings depends on the composition of nutrient. Bats guano contains micro mineral element and complete macro which are very needed by plants. The following high contents of the N, P, and K are: 0.5 – 0.6%, 23.5 - 31.6%, and 0.2%, respectively (Sutanto, 2003). The nitrogen supports the speed growth of the plants, the phosphor stimulates the growth of the roots, flowering, while potassium supports the strength of the rod (Wiyatna, 2002). By using 1.2 tons/ha of guano, rice plant yield can

be increased until 300% (Browne *cit* Sukrido, 2001. According to Rizqiani *et al.*, (2006), the dosage and the frequency of liquid organic fertilizer application on every lowland bean plants can increase the number of the leaves, branches, fruit sets, pods, and the weight of pod per plant or per hectare.

Mulching is a choice of cultivation which can improve the quantity and quality of the plants, and also tries to minimize inorganic input. The benefits of mulch are for suppressing the weeds growth, keeping the soil friable, and stabilizing the temperature and humidity of the soil (Wibarwati, 1977). The use of black-silver plastic mulch gives the best results for the quantity of the fruits, fruits weight, fruits sugar, and pepino's vitamin C (Wirawati, 2007).

Guano and mulch combination can be used for helping bean plants growth on heavy soils. Stand-up bean plants are included on peanuts which the pods are used for vegetables as the protein source (contain 20-28% protein) and calorie (Goldsworthy and Fisher, 1992). Beans are one season plant. Stand-up beans have a high economic potential and quite large market (Cahyono, 2003). The effect for the growth is quite depending on the soil fertility especially the guano dosage and the kind of mulch being used.

MATERIALS AND METHODS

The research was held in Gambiran Village, Pakem, Sleman, DIY Province on July – September 2008. The soil which was used for the experiment was Regosol, located in \pm 425 meters above sea level. The experimental materials were Hawaiian stand-up bean seeds, dung, guano, urea, SP-36, KCL, mulch (white, black-silver, straw), Furadan 3-G[®], curacron[®], and benlate[®].

The experiment was done using field method with Randomized Block Design factorial (3x3) +1 (control) replicated three times. Factor no. 1 was three kinds of guano fertilizer consisted of three dosage, they were: D1 = 150 kg/ha dosage, D2 = 300 kg/ha dosage, D3 = 450 kg/ha dosage. Factor no. 2 was a kind of mulch consisted of three kinds of mulch, they were: M1 = white plastic mulch, M2 = black – silver plastic mulch, M3 = straw mulch. Control = 50 kg/ha urea, 100 kg/ha SP-36, and 100 kg/ha KCl basic fertilizer stand-up bean plants, without giving mulch and guano. The soil preparation was done a week before planting on 7 x 17,7 m² field. The guano fertilizer was given when the soil is being prepared and at the same time the mulch was installed. The harvesting was done after the plants' age 50 days after transplanting.

The observation was covered the plant weight, the anthesis, the pod for each plant, pod length, pod weight per plant, pod weight per swath, and weeds dry weight. The data were analyzed using analysis of variance at 5% significance level and further tested by Duncan's Multiple Range Test with a 5% significance level.

RESULTS AND ANALYSIS

There is no interaction between guano fertilizer and mulch in all of the observed parameter. Guano fertilizer has direct impact on the plant height, the pods, and pod

weight per swath, while the mulch only has direct impact on weeds. The fertilizer and the mulch treatment compared with real control can increase the plant height, pods, and accelerate the anthesis (Table 1), increase the length of the plant, pod weight per swath, the dry weight of the weeds (Table 2).

Table 1. Plant height, anthesis, and number of pods per plant.

Treatment	Plant height (cm)	Anthesis (day)	Number of pods (pod)
Guano Dosage			
D1 (150 kg/ha)	38.63 b	47.44 a	59.33 b
D2 (300 kg/ha)	53.64 a	46.24 a	95.89 a
D3 (450 kg/ha)	41.68 ab	46.32 a	70.89 ab
Mulches			
M1 (white plastic)	44.13 p	47.18 p	70.55 p
M2 (black-silver plastic)	44.96 p	46.43 p	74.45 p
M3 (straw)	44.87 p	46.40 p	81.11 p
Average	44.65 (x)	46.67 (y)	75.37 (x)
Control	31.97 (y)	48.10 (x)	53.67 (y)
Interaction	(-)	(-)	(-)

High concentration of nitrogen is used by the plants for making amino acids source which will be formed protein as protoplasm, enzyme, cell nucleus, etc. In the process of assimilation a cell division is happened, followed by cell enlargement. This is causing the plant grow tall (primary growth) as seen on Table 1 (Darmawan and Baharsjah, 1983). High concentration of phosphate in guano fertilizer causes the plant anthesis faster. According to Darmawan and Baharsjah (1983), phosphate is important in respiratory process and is a part of DNA and ATP. The ATP transformation produces the useful energy for formatting generative organs (flowers, fruits, and seeds). Acceleration of plant anthesis was resulted in increased number of pods.

The dosage increased from 30 kg to 450 kg/ha did not affect the plants height (Table 1), the number of pods each plant and the weight of the pods each swath (Table 2). This was considered because of the limited ability of the plants in absorbing nutrients. According to Sarief (1996), the plants which the need of the nutrient can be fulfilled optimally, the plants will grow well especially the ones related to vegetative growth. Otherwise, the plants will not absorb the nutrients optimally.

Guano has the ability to produce more weight on pods per swath, better than control (without guano). The increasing is about 82.9% (Table 2). That was caused by adding N, P, and K nutrient on guano. The increasing of the plants macro nutrient absorption was stimulated by micro nutrient in guano, which the Mg, Fe, Zn, and Mn as enzyme cofactor pushing the metabolism of the plant (Pranata, 2004).

Mulch treatment is less effective because it did not affect much to all the variables except for the dry weight of weeds (Table 2). This is corroborate with Samanhudi *et al.* research (2007). This was caused by some factors, among of them are the plant canopy, and root systems. In summary, the function of mulches is only as protector for guano nutrient lost from the washing, leaching, and evaporation that can be minimized. Also, mulch may accelerate hydrolysis process of the fertilizer and increase plant metabolism.

Umboh (1997) said that in tropical area with high rainfall level can cause the fertilizer washing bigger. One of the ways approaching to keep the organic element is by giving surface mulch so the temperature of the soil decreasing and protect from erosion.

Table 2. Pods number/plant, pods length/plant, pods weight/swath, weeds dry weight.

Treatment	Pods length/plant (cm)	Pods weight/plant (g)	Pods weight/swath (g)	Weeds dry weight (g)
Guano Dosage				
D1 (150 kg/ha)	13.91 a	258.71 a	575.08 b	13.65 a
D2 (300 kg/ha)	15.35 a	443.29 a	1210.60 a	14.64 a
D3 (450 kg/ha)	16.77 a	354.60 a	851.64 ab	16.29 a
Mulches				
M1 (white plastic)	14.89 p	362.93 p	839.35 p	1.71 q
M2 (black silver plastic)	17.06 p	332.86 p	895.36 p	0.73 q
M3 (straw)	14.08 p	360.80 p	902.61 p	42.13 p
Average	15.34 (x)	352.20 (x)		14.86 (x)
Control	12.00 (y)		879.11 (x)	12.00 (y)
Interaction	(-)	(-)	484.23 (y)	(-)

Table 2 shows that the mulches have real act to suppress the growth of the weeds. The use of plastic mulch either white or black-silver one, has the same effect to dry weight of the weeds which is decreasing the dry weight of the weeds compared to the use of straw mulches. The plastic mulch will cover the soil so it will be dark. With no light, it cause the weeds under the plastic mulch can not perform photosynthesis.

CONCLUSION

With the limitation only on the research done, it can be concluded that:

1. There is no interaction found between the treatment of mulches and guano dosage up on all of the observed parameters.
2. Guano dosage of 300 and 450 kg/ha have significant effects on increasing the plants height, accelerating plants anthesis, increasing pods number of each plants, and increasing pods weight until 82.9%.
3. The plastic mulch and black-silver plastic have the same effect in decreasing the dry weight of the weeds and no significant effect on weight of the plants, plants anthesis, pods number of each plant, and pods weight per ha.

REFERENCES

- Cahyono, B. 2003. *Kacang Buncis, Teknik Budidaya dan Analisis Usaha Tani*. Kanisius. Yogyakarta. 128 h
- Darmawan, J. dan J. S. Baharsjah. 1983. *Dasar-dasar Fisiologi Tanaman*. Penerbit P.T. Suryandaru Utama. Semarang. h. 88
- Goldsworthy dan Fisher. 1992 Goldsworthy, P. R. dan Fisher, N. M. 1996. *Fisiologi Tanaman Budidaya Tropik*. Gadjah Mada University Press. Yogyakarta. 874 h.

- Pranata, A. S. 2004. *Pupuk Organik Cair Aplikasi dan Manfaatnya*. Agromedia Pustaka. Jakarta.
- Raharjo. 1999. Pengaruh Pengolahan Tanah dan Dosis Pupuk Kandang Terhadap Beberapa Sifat Tanah Tanaman Jagung. *Bull. Penel. Hort.* Lembang. Bandung IX (21) : hal 136-141.
- Rizqiani, N. F., E. Ambarwati, dan N. W. Yuwono. 2006. Pengaruh Dosis dan Frekuensi Pemberian Pupuk Organik Cair Terhadap Pertumbuhan dan Hasil Buncis (*Phaseolus L. vulgaris*) Dataran Rendah. *Jurnal Ilmu Pertanian*. Vol. 13 NO.2. September 2006.
- Samanhudi, W. Wiryowidodo, Suwanto, dan S. Hudaya. 2007. Kajian Dosis Pupuk Nitrogen dan Macam Mulsa Terhadap Pertumbuhan dan Hasil Tanaman Kubis Di Dataran Rendah. *Prosiding Seminar Nasional Hortikultura*. Surakarta, 17 Nopemper 2007.
- Sutanto, R. 2003. *Penerapan Pertanian Organik*. Kanisius. Yogyakarta. 219 hal.
- Umboh, A. H. 1997. *Petunjuk Penggunaan Mulsa*. Penebar Swadaya. Jakarta. 89 h.
- Wibarwati, E. Y. F. 1997. *Sistem Mulsa Lanjaran Budidaya Melon*. Suara Karya. Jakarta. h. 7. Kol. 1-5.
- Wiyatna, M. F. 2002. *Potensi Indonesia Sebagai Penghasil Guano Fosfat Kelelawar*. Agromedia Pustaka. Jakarta. H 25 – 27.
- Wirawati. T. 2007. Kajian Pupuk Organik, Mulsa dan Pengaruhnya Terhadap Tanaman Pepino. *Prosiding Seminar Nasional Hortikultura*. Surakarta, 17 Nopemper 2007.

STUDY OF GROWTH HORMONE GENE VARIETY BASED ON BIOINFORMATICS

Mariana Rengkuan

Universitas Negeri Manado, Jln.Kampus UNIMA di Tondano 95618

ine_renkuan@yahoo.com

ABSTRACT

The aim of this research was to investigate the variety of beef cattle from Balai Besar Inseminasi Buatan Singosari and Perusda Pasuruan using bioinformatics. The research started with prime design referred to NCBI (The National Center For Biotechnology Information) database and acquired beef cattle's blood. The blood had been extracted to obtain the DNA which then amplified to obtain the target gene that was growth hormone gene. Furthermore, the gene was being sequence. The result from the sequencing was analyzed by MEGA (Molecular Evolutionary Genetic Analysis) 5.03 software program's which showed the genetic variety in 13 samples, indicated by the altering of nucleotide base. There was a close genetic length among 1 sample from BBIB Singosari (sample 12) and 7 samples from UPA Pasuruan (sample 1,2,3,4,5,6, and 7) whereas the genetic length was 0.000 whilst 2 samples from BBIB Singosari (sample 11 and 13) displayed a close genetic length with 1 sample from UPA Pasuruan (sample 8). However, in general 13 samples have close genetic length amongst samples, which are 0.002 and 0.004.

INTRODUCTION

Biology as a branch of science has been developed to answers some problems in life. This development had been perceived in molecular biology study. The study of molecular biology has become more developed with the inventions from base experiments in laboratory. The experiments results which is biology's process data in molecular level can be analyzed using bioinformatics approach.

The developments in bioinformatics as a new science had been contributed in order to overcome some obstacles in analyzing researches data in molecular biology field. The programs as well as the data that related to molecular biology can be accessed easily through the internet, for example to obtain nucleotide sequence that restored in GenBank, to analyze the similarity level with multiple sequence alignment used Clustal-W, to compare a sequence with the library sequence in GenBank using Basic Local Alignment Search Tool (BLAST) program, to design primer, and to identify restriction enzyme site in DNA helix. The same approach can be used in veterinary field as an effort for plasma nutfah preservation and to support the availability of meat in Indonesia which contributes in food sustainability.

One of the germ plasm that contributes in effort of self-supporting meat was beef cattle. Some actions have been done by Indonesian government and private sector in order to increase the population and productivity of beef cattle in Indonesia. These can be found in some centers in Indonesia, such as BBIB Singosari and some district companies in East Java (PERUSDA). These two centers have some programs which aimed to increase population and productivity of locals breed in Indonesia, for example Ongol breed cow (PO) as beef cattle. To achieve these aims, some programs had been done, such as improvements in maintenance management, food, and genetics. Genetics improvement can be done through selection and crossbreed. Selection can be conducted in gene level that control certain property and can be inherited (Corebima and Rengkuan, 2012).

One gene that has been reported from previous researches (Lucy dkk., 1991, Hojdkk., 1993, Schleedkk., 1994, Sutarnodkk., 2010), was growth hormone gene which can be used as a candidate gene to investigate the quality of beef cattle in term of economic characteristic. Growth hormone gen was a gene that can be influenced growth because it has some physiology activities (Reis et al, 2001). Cunningham (1994) and Hojet al (1993) reported that growth hormone gene has a major role in organize growth properties, reproduction, metabolism, lactation, and mammary gland maturity. This enable researcher to conduct studies in gene level, which was growth hormone gene, to understand the genetic variety of beef cattle in Indonesia utilize bioinformatics. It was necessary study to apprehend the genetic quality of beef cattle from BBIB and PERUSDA in East Java. This goes along with Sutarno's opinion (2006) that the variety of growth hormone gene can be used as a potential candidate of cattle growth property marked gene. The aim of this reach was to study the variety of growth hormone gene in cattle breed ongole (PO) from BBIB and PERUSDA Pasuruan.

MATERIALS AND METHODS

A. Time and Location

The sampling of this research has been conducten in BIIB Singosari and PERUSDA in Pasuruan. The blood sample was analyzed in Molecular Biology Laboratory Brawijaya University and Islamic State University malang. This research has been conducted for 8 month, from December 2010 through August 2011.

B. Materials

This research utilized all superior male cows PO from BBIB Singosari, which are 3 cows superior bull and 10 cow PO that used as mater in reproduction in UPA Pasuruan.

C. Growth Hormone Gene Prime Design

The prime design conducted based on NCBI database. Growth hormone gene (GH) Bosindicus breed butane referenced to GenBank: EF592533.1 which is a complete CDS coding (DNA sequence). The design conducted using oligo Analyzer 1.02 software and BLAST available in NCBI. The growth hormone gene primer design outcome is the length of amplification around 393 bp. The primer design tested with

oligo Analyzer 1.02 software comprise % GC contents, T_m, loop test, dimmer test, and multiplex test between forward primer and reverse primer.

Table.1: Primer Design for Growth Hormone Gene Amplification

P r i m e r S e q u e n c e	L e n g t h b p	
	P r i m e r	A m p l i c o n
forward 5'-CGGAGGGACAGAGATACT-3'		
Reverse 5'-CCGTAGTTCTTGAGCAGC-3'	18	393

D. DNA Isolation from Leucocyte

The pellet that form leucocyte is added 750 µl cell lysis solution and then homogenized by the way of pipeting. It was incubted at level of 37⁰C temperature for 15 minutes then precipitation protein was added was much as 500 µl then the vortex process was made, centrifuged with a speed of 7000 rpm, temperature level 40⁰C, for 15 minutes. The supernatant was moved to the new tube, added 2250 µl cool ethanol then the tube was inverted 25 to 30 times until the white DNA band appeared. After that, it was centrifuged with a speed of 10.000 rpm, 40⁰C temperature for 15 minutes and then supernatant waas disposed. The process was continued by adding 3 ml of with 70% cold ethanol, inverted for a few times, centrifuged with a speed of 10.000 rpm, in 40⁰C temperature for 15 minutes and then ethanol was disposed. Next treatment was the remain pellet then wind-dried at level of room temperature then added 100 µl TE buffer, placed at oven wirh temperature of 37⁰C for 10 minutes and kept at the level of -20⁰C temperature.

E. Quantitative Measurement of DNA using Spectrofotometer

DNA purity and concentrationwas conducted by using spectrofotometer (Genesys 10) with the wave length 260 nm and 280 nm as described by Fatchiyah et., al., (2007).

F. Qualitative Measurement of DNA using Agarose Electrophores was2%

Agarose is weighed as much 0,3 g and fused into 15 ml of TBE and then heated until all fused. The solution gel is refrigerated until warm (+45oC) then added EtBr as much as 0,8 µL and moulded using gel mould which is set tool comb-like. Then let the gel condensed dan the tool like a comb is dropped, after that the gel is moved to electrophoresis chamber then it is filled with TBE until the gel damped. As much as 4 µL of DNA sample, the result of isolation, is added 3 µl loading dye, put into gel well. The electrophoresis is carried out using voltage 100 volt more or less 1 hour. The result of running then outstretched upon UV transluminator.

G. DNA Amplification using PCR

Amplification of hormon gene of PO Cattle growth is made by Polymerase Chain Reaction (PCR) method. PCR is made by mixing aquadest steril 4 μ l and PCR mix 10 μ l. The reaction is started by adding 2 μ l DNA sample as template and 2 μ l for each primer. Amplification is executed to PCR tool (gene cycler), programmed in accordance with used paired primer. The used primer is 5'-CCCACGGGCAAGAATGAGGC-3' as forward and 5'-TGAGGAACTGCAGGGGCCCA-3' as reverse, in which each primer can recognize gene sequence located in 2054-2074 bp for primer and gene sequence located in 2457-2337 bp (Sutarno, 2010). Gene cycler is programmed in accordance with used primer, that is hot start at 94°C temperature during 1 minute, denaturation at 94°C temperature during 1 minute, annealing at 60°C temperature during 1 minute, extension at 72°C temperature during 1 minute and ended with post extension at 72°C temperature during 5 minutes. The amount of amplification are 30 cycles.

H. Sequencing PCR Result

The sample of the result of amplification is continued to the stage of sequencing, beforehand purified using ethanol method/EDTA precipitation. Then it is continued to the stage of sequencing with reagent ABI PRISM BigDye Terminator v3.1 cycle sequencing kit. This sequencing process is made by the analysis merit of the laboran of State Islamic University, Malang.

I. Data Analysis

The data of PCR result is used to know the existence of growth hormone gene. It was done by observation of the photo of agarose electrophoresis result, whereas the sequencing data was used to confirm the sequence of PCR result and each sample was traced and confirmed between the result of forward primer sequence and reverse primer sequence to each gene by using software sequence scanner v.10 and software Bioedit. Then, the result of sequencing was confirmed by using BLAST (Basic Local Alignment Search Tool) programme which can be found in NCBI website. It was used to know whether growth hormone gene in GenBank has similarity with gene sequence of growth hormone of cattle which was the sample of this research.

RESULT AND DISCUSSION

The research's results are amplification and growth hormone gene sequencing of superior male cow PO from BBIB Singosari and mater from UPA Pasuruan. In amplification result of growth hormone gene from superior male cow PO in BBIB Singosari and mater cow from UPA Pasuruan can be conducted with PCR method used primer from previous research by Rengkuan *et al* (2011) which has been constructed from growth hormone gene of cow breed butane with prodak length of \pm 790 bp from overall 1793 bp (Hediger *et al*, 1990). The amplification result of GH gene fragment from cow all over location visualized into agarose gel 1.5% (Figure 1). However the design result in Table 1 shown that the length of growth hormone gene is different from the amplification result. Therefore it needed to be continued to sequencing process.

Sequencing result then matched with BLAST in NCBI. BLAST result shown growth hormone gene of PO cow is compatible with growth hormone gene database in NCBI.

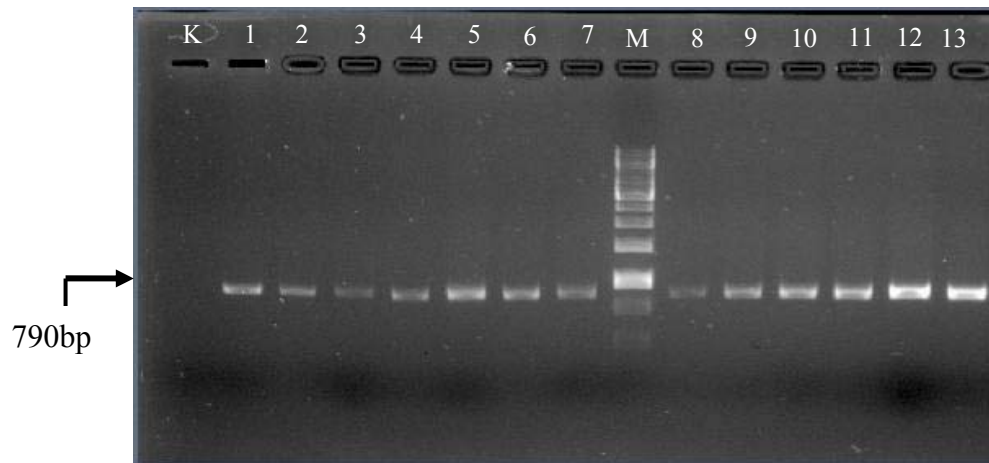

Fig. 1: Amplicitation Result of Co PO Growth Hormone Gene in Agarose Gel 1.5% note.: M: Marker; K: control; 1-10: Samplefrom UPA; 11-13: Samplefrom BBIB

The next step is to sequence in order to confirm the amplification result and to comprehend the variation of PO cow growth hormone gene in the sample. Sequencing result then confirmed with BLAST to investigate whether the growth hormone gen from GenBank identical with the sequence of PO cow growth hormone gen. BLAST result displayed samples utilized in the research have high homology value against cow’s growth hormone gene from GenBank, which is identic around 98%. The sequencing results data then aligned with CLUSTAL W (1.4) multiple sequence alignment to obtain the variation of superior male PO cow growth hormone gene from BBIB Singosari and mater cow from UPA Pasuruan.

The alignment result from 13 samples demonstrated that there were two variations of nucleotide in 790 bp (Figure 2) from overall 1793 bp growth hormone gene (Hediger *et al.* 1990). These two variations allegedly happened because of transition mutation, which is timin became citosin in samples 1-9 and 10.

Sampel	Variasi Sekuen Gen Hormon Pertumbuhan Sapi PO
13	TGGGGCGGGCCTTCTCCCCGAGGTGGCGGAGGTTGTTGGATGGCAGTGGAGGATGATGGTGGGCGGTGGTGGCA
12
11
9
10
8
7
6
1
2
3
4
5

Figure 2a. Difference in Arrangement of Nucleotide Base of Growth Hormone Gene from PO Cow in BBIB and UPA

Sampel	Variasi Sekuen Gen Hormon Pertumbuhan Sapi PO
13	G A G G T C C T C G G G C A G A G G C C G A C C T T G C A G G G C T G C C C C A A G C C C G C G G C A C C C A C C G A C C A C C C A T C T G C C A G
12
11
9
10
8
7
6
1
2
3
4
5

Figure 2b. Difference in Arrangement of Nucleotide Base of Growth Hormone Gene from PO Cow in BBIB and UPA

Note: Samples no 1, 2, 3, 4, 5, 6, 7, 8, 9, 10: Samples from UPA and Samples no 11, 12, 13: Samples from BBIB

Sampel	Variasi Sekuen Gen Hormon Pertumbuhan Sapi PO
13	C A G G A C T T G G A G C T G C T T C G C A T C T C A C T G C T C C T C A T C C A G T C G T G G C T T G G G C C C C T G C A G T T C C T C A G C A G
12
11
9
10
8
7
6
1
2
3
4
5

Figure 3a. Difference in Arrangement of Nucleotide Base of Growth Hormone Gene PO Cow from BBIB and UPA

Sampel	Variasi Sekuen Gen Hormon Pertumbuhan Sapi PO
13	A G T C T T C A C C A A C A G C T T G G T G T T T G G C A C C T C G G A C C G T G T C T A T G A G A A G C T G A A G G A C C T G G A G G A A G G C A
12 T
11
9
10 T
8 T
7 T
6 T
1 T
2 T
3 T
4 T
5 T

Figure 3b Difference in Arrangement of Nucleotide Base of Growth Hormone

Gene PO Cow from BBIB and UPA

Sampel	Variasi Sekuen Gen Hormon Pertumbuhan Sapi PO
13	TCCTGGCCCTGAGGAAGGCATCCTGGCCCTGATGCGGGTGGGGATGGCGTTGTGGGTCCCTTCCATGCTGGGGG
12
11
9
10
8
7
6
1
2
3
4
5

Figure 3b Difference in Arrangement of Nucleotide Base of Growth Hormone Gene PO Cow from BBIB and UPA

Note.: Samples no 1, 2, 3, 4, 5, 6, 7, 8, 9, 10: Samples from UPA and Samples no 11, 12, 13: Samples from BBIB

Sampel	Variasi Sekuen Gen Hormon Pertumbuhan Sapi PO
13	CCATGCCCGCCCTCTCCTGGCTTAGCCAGGAGAAATGCACGTGGGCTTGGGGAGACAGATCCCTGCTCTCTCCCT
12G.....
11
9G.....
10G.....
8
7G.....
6G.....
1G.....
2G.....
3G.....
4G.....
5G.....

Figure 4a. Difference in Arrangement of Nucleotide Base of Growth Hormone Gene PO Cow from BBIB and UPA

Sampel	Variasi Sekuen Gen Hormon Pertumbuhan Sapi PO
13	CTTTCTAGCAGTCCAGCCTTGACCCAGGGGAAACCTTTTCCCTTTTGAAACCTCCTCCTCGCCCTTCTCC
12
11
9
10
8
7
6
1
2
3
4
5

Figure 4b. Difference in Arrangement of Nucleotide Base of Growth Hormone Gene PO Cow from BBIB and UPA

The variety of cow's growth hormone gene in 13 samples produced genetic length which can describe the difference of male superior cow samples from BBIB Singosari with mater cow from UPA Pasuruan (Figure 5 and table 2)

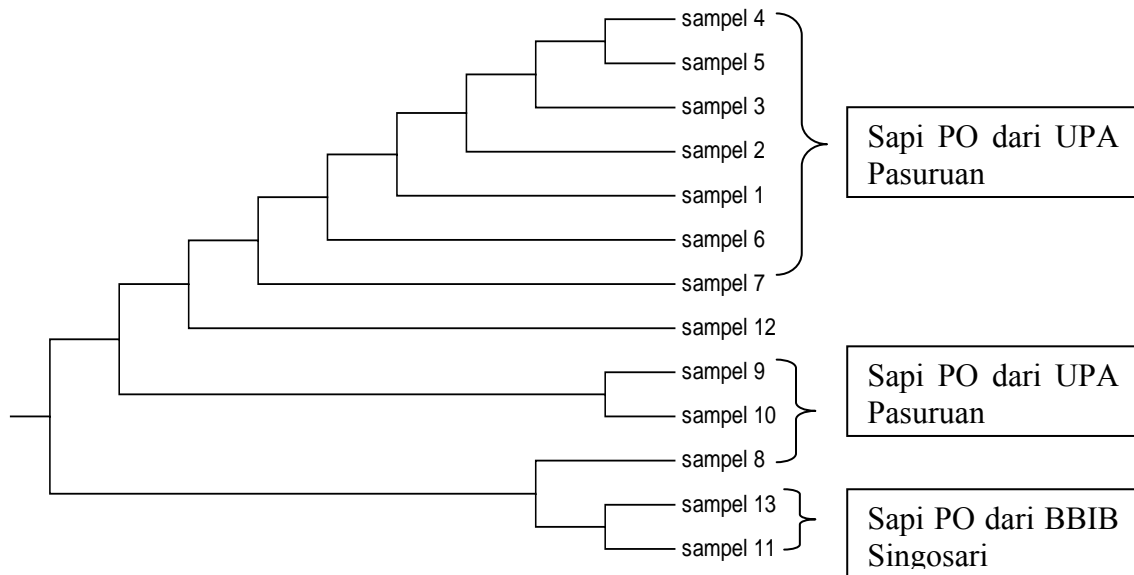

Figure 5 Filogeni Tree of UPGMA Sequence Data from Growth Hormone gene from Cow in BBIB and UPA

In the figure above shown 3 major group whereas in group consist of 1 sample from BBIB Singosari (samples no 12) and 7 samples from UPA Pasuruan, then 2 samples from UPA Pasuruan in group II (samples 9 and 10) and 3 samples in group III which consist of 2 samples (samples 11 and 13) from BBIB Singosari and 1 sample (sample 8) from UPA Pasuruan.

Table 2 Genetic Length of 13 Sequences of Cow PO Growth Hormone Gene

Sample	1	3	1	2	1	1	9	1	0	8	7	6	1	2	3	4	5
1	3																
1	2	0.004															
1	1	0.000	0.004														
9		0.002	0.002	0.002													
1	0	0.002	0.002	0.002	0.000												
8		0.002	0.002	0.002	0.004	0.004											
7		0.004	0.000	0.004	0.002	0.002	0.002										
6		0.004	0.000	0.004	0.002	0.002	0.002	0.000									
1		0.004	0.000	0.004	0.002	0.002	0.002	0.000	0.000								
2		0.004	0.000	0.004	0.002	0.002	0.002	0.000	0.000	0.000							
3		0.004	0.000	0.004	0.002	0.002	0.002	0.000	0.000	0.000	0.000						
4		0.004	0.000	0.004	0.002	0.002	0.002	0.000	0.000	0.000	0.000	0.000					
5		0.004	0.000	0.004	0.002	0.002	0.002	0.000	0.000	0.000	0.000	0.000	0.000				

Note: Samples no 1, 2, 3, 4, 5, 6, 7, 8, 9, 10: Samples from UPA and Samples no 11, 12, 13: Samples from BBIB

Table above display genetic length of 13 samples. Amongst these samples, there is a very close genetic length between 1 sample from BBIB Singosari (sample 12) and 7 samples from UPA Pasuruan (samples 1,2,3,4,5,6, and 7), which value is 0.000, whilst 2 samples from BBIB Singosari (samples 11 and 13) displayed a close genetic length with 1 sample from UPA Pasuruan (sample 8). However, in general 13 samples have close genetic length amongst them, which are 0.002 and 004.

Based on these results, it is revealed that the sequences of growth hormone gene that used in this research have no significant variant among its samples. However, it can be demonstrated the genetic relationship between male superior cow and mater cow Pao that utilized as PO parent that produce its descent. This descent used by catle breeder in East Java, and generally in Indonesia. Therefore this result can be a usefull input for these two centers to conduct for male selection as well as female cow which later will be mated. From the groups made of the UPGMA result, whereas male and mater included in the same group, then the samples can not be used as PO parent. This can be explained through genetics variety concept, where genetic variety is needed in term of genetics preservation. A related research conduct by Schlee et al (1994) shown the growth hormone gene variety can influence to the growth and meat production of catle. This can be explained as polymorphysm in growth hormone gene can caused difference in hormone syntesize, therefore the difference in hormone concentration/sirculation formed. This difference can caused growth variation among each individual. This goes along witu opinion from Sutarno (2006) that the variation of growth hormone gene can be a potential candidate for marker gene of catle growth property.

CONCLUSION

Genetic variety found in some of this research samples using growth hormone gene, which is in samples from BBIB Singosari and PERUSDA Pasuruan, but there are some samples that have 0.000 of genetic length whilst the other sample also have a relatively close of genetic length, which are 0.002 and 0.004. Based on this result, in can be concluded that among the 13 samples that used, there is no genetic variation. Therefore if a crossbeed have been conducted between male and female PO cow in BBIB Singosari and UPA Perusda will form descent of mated which called inbreeding. Inbreeding will form a descent that has a downfull impact because it can influence in productivity and reproduction of individual. Therefore this research can give recomendation to these two centers to conduct selection genetically in molecular level in order to prepare high quality male and female cow for ongole breed catleman society.

ACKNOWLEDGEMENT

Special thank to Prof. Dr. Duran Corebima, M.Pd and Prof. Dr. B. Sutiman, D.Sc for their ideas input. We also acknowledge to the Higher Education Directorate, the National Education Department of Indonesia for funding this research.

REFERENCES

- Cunningham, E. P. 1994. The Use of Bovine Somatotropin in Milk Production. *Irish Veterinary Journal* vol 47, 207-210.
- Fatchiyah, Arumingtyas, Widyarti, dan Rahayu. 2007. *Molecular Biology Analisis*. Malang: Fakultas Pertanian Universitas Brawijaya Press.
- Hoj, S., M. Fredholm, N.J. Larsen, and V.H. Nielsen. 1993. Gene Polymorphism Associated With Selection For Milk Fat Production in Lines of Cattle. *Animal Genetics*, vol. 24: 91-96.
- Lucy, M.C., S.D. Hauser, P.J. Eppard, G.G. Krivi, and J.H. Clark. 1993. Variants of somatotropin in cattle - gene frequencies in major dairy breeds and associated milk production. *Domestic Animal Endocrinology*, vol. 10: 325-333.
- Reis, C. D, Navas, N. Pereira, and Cravador, A. 2001. Growth Hormone Alui Polymorphism Analysis in Eight Portuguese Bovine Breeds. *Arch. Zootec*, vol. 50, pp. 41-48.
- Rengkuan, M., Corebima, A. D. Sumitro, S. B., Amin, M. 2011. Amplification and Sequencing Growth Hormone Genes in the Nurseri Center for PO Cattle on Balai Besar Inseminasi Buatan (BBIB) Singosari and Unit Perusahaan Aliansi (UPA) Pasuruan. International Proceedings of ICBB. Yogyakarta: International Conference On Bioscience And Biotechnology.
- Corebima, A.D., and Rengkuan M. 2012. The Detection of Superior PO Cattle Based on The Growth Hormone Gene Sequence. Internasional Proceedings of Chemical, Biological and Environmental Engineering.
- Schlee, P., R. Graml, O. Rottmann, and F. Pirchner. 1994. Influence of Growth-Hormone Genotypes on Breeding Values of Simmental Bulls. *Journal of Animal Breeding and Genetics Zeitschrift fur Tierzuchtung und Zuchtungsbiologie*, vol. 11: 253-256.
- Sutarno. 2006. Used of Molucular for Improved animal Production, (Online), (http://si.uns.ac.id/profil/uploadpublikasi/pengukuhan/pengukuhan_sutarno).
- Sutarno, 2010. Genetic variations among Indonesian native cattle breeds based on polymorphisms analysis in the growth hormone loci and mitochondrial DNA. *Biodiversitas*. Volume 11, no 1, (<http://www.jvetunud.com>), diakses 20 Juni 2010).

SWOT ANALISYS FOR INTEGRATED ECO-TOURISM DEVELOPMENT IN STRENGTHENING NATIONAL RESILIENCE (CASE STUDY IN GAJAH WONG RIVER, YOGYAKARTA, INDONESIA)

Istiana Rahatmawati

UPN "Veteran" Yogyakarta

e-mail: rahatmawati@yahoo.com

ABSTRACT

River used to be the center of human activities as water is the source of life. As we know many kingdoms were situated nearby the river and some of them fight for water resources. The development of science and technology had been brought many options to get water. Nowadays, in many urban areas, rivers are no longer strategic location for living. Evenmore, river used for illegal housing or the shelter of marginalized people and terminal of waste and garbages. Riverside becomes slums area. Poverties, crimes and other social problems seem to be the mark of the riverside area. This should not be happened. It must be found the way out. Rivers have to be revitalized as resource water and its ecosystem including Gajah Wong river in Yogyakarta. The uniqueness of this river is the water resources from 24 springs, flows to the South Ocean. The development of integrated eco-tourism will perform sustainable development and accelerate the strength of National Resilience. The purpose of this research was to analyze Gajahwong integrated eco-tourism in Yogyakarta. The method of this research was Descriptive Qualitative. Data collecting by direct observation, Focus Group Discusion, in-depth interview, documentations. This research used SWOT (Strength, Weaknesses, Opportunities and Threats) analysis. The result shows that the development of integrated eco-tourism in Gajah Wong river will significantly generate the strength of National Resilience. The recommendation of this research is that the synergy of five pillars namely Local Community, Local Government, Academician, Investor and National Policy is really needed.

Keywords: Eco-tourism, National Resilience, Integrated, Synergy .

INTRODUCTION

Yogyakarta is famous as one of the main tourist destination in Indonesia. Yogyakarta is on the ninth rank for the number of visitors (2.460.967 visitors in the year of 2010) and on the fifth rank for the most favourite tourist destination city (Ministry of tourism, 2010). There are three rivers in Yogyakarta city, namely: Code; Winongo and Gajah Wong. Each of them has their own characteristic. Code river for instant, regularly floats ones in eight years in average; Winongo river tends to depend on the season. Much water flows in rainy season and less in dry season. Gajahwong has

specific and unique characteristic. Specific because of its heritage, connect to the history of Mataram Kingdom in Yogyakarta in the past. And it also unique because the source of river water is comes from 24 springs along the body of the river which is flows to the south ocean. So, the quantity of Gajah Wong river water relatively constant rather than another both rivers. The riverside area of Code; Winongo and Gajah Wong and many other rivers in the cities in Indonesia more or less has similar social and economic problems. Slums area, polluted rivers, crimes, illiteracy, uneducated people, unemployment, poverty, seems to be the identic problems. Without serious attention and action to solve, these problems will impact to many aspect of National Resilience (Natural resources; Human resources; ideology; politics; economics; social and culture; Defence and Security), which is mean also the sustainable development's barrier. There are many anchient heritage situated along the Gajah Wong riverside area. Unfortunately these heritages are not well regarded and some of them disappear of people destructions. In the Gajah Wong riverside, also situated culture village (Giwangan village), the center of culture area, which is the habitants have various groups of hobbies and economics activities. Developing Gajah Wong river must be aware of environment aspect. The spirit of Yogyakarta Special Territory "*Mamayu Hayuning Bawono*" determined to Yogyakarta City's Plan of Action "*Segoro Amarta*" (*Semangat Gotong Royong Agawe Maju Yogyakarta*) in developing Gajah Wong river area. Three main indicators in developing river area, there are: 1. Health river; 2. Health residential area and 3. Economic Growth (Government's Regulation: *UU No. 13 Th 2012 tentang Keistimewaan DIY – Rancangan Perdais Pemda DIY tentang Tata Ruang*). By developing river, maintenance heritages and integrating eco-tourism along the Gajah Wong river in Yogyakarta city will push the economic growth and other social aspects. The sustainable development will occur and the national resilience getting stronger.

AIMS

This paper present the strengths, weaknesses, opportunities and challenges in order to establish the integrated eco-tourism in the Gajah Wong river area in Yogyakarta city. The development of integrated eco-tourism supports sustainable development in accelerating the strenght of National Resilience.

METHODOLOGY

This research conducted as Field Research. The definition of Field Research is any activities aimed at collecting primary (original or otherwise unavailable) data, using methods such as face to face interviewing, telephone and postal surveys and direct observation ([www. Businessdictionary.com/definition/field-research.html](http://www.Businessdictionary.com/definition/field-research.html)). The method of this research is Descriptive Qualitative. This study was analyzed by SWOT analysis. The respondent is the key person. They are, related governmental institution namely Balai Besar Wilayah Sungai Serayu Opak (BBWSO), Badan Lingkungan Hidup (BLH DIY), Badan Pengelola Daerah Aliran Sungai (BP DAS DIY), Dinas Kebudayaan (Culture Office of Yogyakarta), Dinas Pariwisata (Tourism Office of Yogyakarta), Camat (The chief) of Umbulharjo District, Kepala Desa (The chief) of seven villages along Gajah Wong river area, seven river guards (Ulu-ulu), RW (formal community leader), Gajah Wong Community Forum (Forsidas Gajah Wong), Groups of hobbies

and economic activities. The data collected by direct observation, focus group discussion, in-depth interview and documentation

RESULT AND DISCUSSION

A. Yogyakarta profile

Yogyakarta has strategic position as the capital city of Yogyakarta province and the center of regional activities of Yogyakarta special Province area and southern Java. It perform the specific activities patterns, potencies and problems as open area with high mobilization. This condition drives Yogyakarta to urban society which is depending on services sector rather than manufacture sector in big scales production. The Yogyakarta city has 3.250 Ha or 32.50 Km² wides (only 1,2 % of Provinve's width) with the farrest distance 7.5 Km from north to south and 5.6 Km from west to east. Yogyakarta has 14 districts, 45 villageS. Most of land use for residential 2.103,27 Ha and only 20.20 Ha vacant areas. The widest district is Umbulharjo which is most of the body of Gajah Wong river lied on this district in the Yogyakarta city. It has 812.00 Ha or 24,98 % of Yogyakarta's width.

There are 3 rivers flows from north to south deviding Yogyakarta namely Gajahwong in the east, Code in the center of city and Winongo in the west. After the eruption of Merapi Volcano, Yogyakarta face the threat of lahar float disaster as Merapi located in the north of Yogyakarta and the lahar flows down into the rivers. In the end of the year 2010, the Merapi eruption had threatred the people who lives and do their activities in 16 village situated alongs Code river. According to this threat, Yogyakarta government has to be ready to handle it.

In the year of 2010 there are 457.668 people lives in Yogyakarta. The poverty data in the year 2007 shows that Yogyakarta has 89.818 poor people but in the year of 2010 decrease to 65.371 poor people. The poverty centered on the marginal area and most of poor people living in the illegal area such as in the riverside that make the riversides become slums area. The poor people residential usually not well organize and there is no basic residential facility (unproper residential). The percentage of unproper houses is 4.36% in the year of 2010. Until the end of the year 2011 there are 1.979 unproper houses. (Kimpraswil Kota Yogyakarta, 2010). The changing of poverty standards and the inflasion also impact to increase the number of not poor jump into poor people category if they cannot be able to increase their welfare.

B. The Vision and Mission of Yogyakarta 2005-2025

The Vision of Yogyakarta Development 2005-2025

According to the condition, problems and challenges in 20 years from 2005 and by calculates the strategic factors and the potencies of Yogyakarta, the vision of Yogyakarta Development 2005-2025 is "Yogyakarta as Qualified Educational City, Tourism Based on Culture and Services Serving Center which is aware of environment". (The Document of RPJPD Kota Yogyakarta 2005 – 2025)

The Mission of Yogyakarta Development 2005-2025 to perform the vision is by nine Development Mission as follows:

1. Maintain the predicate of Yogyakarta as educational city
2. Maintain the predicate of Yogyakarta as tourist city, Culture city and Struggle city
3. Creating the competitive power of Yogyakarta the prime in serving public service
4. Making Yogyakarta nice place to live and friendly to the environment
5. Performing Yogyakarta people that honours to moral, ethics, humanism and culture
6. Performing Yogyakarta a *good governance*, clean government, justice, democratic and based on laws
7. Performing Yogyakarta secure, in order, unity and peace
8. Performing qualified structure and infrastructure development
9. performing healthy Yogyakarta

C. National Resilience Theory

National Resilience is National dynamic conditions contains strengths and perseverances in facing challenges, threats, barriers and inferences which are threaten national identity, integrity and existency in many aspects namely ideology, politics, economics, social-cultural, defense and security (Lemhannas RI, 1999). There are eight elements of national resilience called Asta Gatra, consist of Tri Gatra and Five Gatra. Tri Gatra are three natural elements of national resilience, there are Location and geographically position of the country, Natural Resources and Human Resources. Panca Gatra are five social elements of national resilience there are Ideology, Politics, Economics, Social, Cultural, Defense and Security. These eight elements all together build the performance of the national resilience. The eight elements Asta Gatra are integrated as one gestalt power and there is inter-related and correlation among the element. One dynamic condition element influences to the dynamic condition another. Gestalt means when the power of one element plus another one power of element the result is much bigger than just adding the number of the two single power of element. Economic Gatra/element extremely influences another gatra. When Economic Gatra is strong, it will be able to: (1) buy high-tech protection system to guard the state and the border. (2) Financing the exploration of national natural resources that builds the proudness of the nation. (3) Providing technology and opportunity to accelerate the quality of human resources. (4) Strengthening the national ideology. (5) Establish democracy and politic stability. (6) Establish social stability and strengthening national social-cultural. (7) Performing the national defence and security. In the contrary, when the economic gatra/element of national resilience is weak, the poverty drives people against the law in order to fulfill their basic needs for living. The crimes, illiteracy, blind democracy, unsecure, unpeace and all can be disorder.

National resilience is a welfare and security concept to reach the welfares and conduct the national security in the same time. Remaining that economic growth can accelerate the welfare and also that the development should be sustain, the development of integrated tourism alongs the Gajah Wong river is the best solution for poverty problem solving and creating the new strategy of tourism product.

D. Gajahwong River and Integrated Eco-tourism

Gajahwong river has 8 Km long from north to the south passing through three district and seven village of Yogyakarta, One District and two villages in Sleman Regency, three Districts and five villages in Bantul regency. In Yogyakarta city, Umbulharjo District has the longest part of Gajahwong river which is situated in five villages there are: Mujamuju, Rejowinangun, Warungboto, Pandeyan and Giwangan. The long is about 7 Km in the west side of the river and about 2 Km in the east side of the river. The water quantity is relatively stabil because the source of river water is from 24 springs in the body of Gajahwong river. Before the year 2000, there are about 49 springs, but in the year of 2012 only 24 springs left (Forsidas Gajah Wong, 2012). The water of these springs is all in good qualities. It had been tested in the laboratory and the result shows zero bacteria colie in it. Unfortunately people's behavior makes Gajah Wong river called the most polluted river in Yogyakarta. BLH DIY (2012) declare that all rivers in Yogyakarta Province are polluted of BOD, Chlorine, Sulfide, Zink, Magnecium, methal and bacteria collie and the worse is Gajah Wong river. There is not any attention from the government, as government not provide fund for Gajah Wong development in the year 2013 but will provide it for the next year.(Bappeda, Yogyakarta,2013). Considering the quantity of the water, in Giwangan was built a dam to collect the Gajahwong river water for irrigation purpose. Gajah Wong river had been watering 40.000 Ha ricefields in Bantul Regency (in the south of Yogyakarta city, southern of Yogyakarta special Province).

There are many tourist area along the Gajah Wong riverside area which are not integrated yet. From the north to the south there are: Affandi Art Gallery, Gembira Loka Zoo (in Mujamuju village), Springs Heritage: Umbul raja, Umbul Naga, Umbul Lanang, Umbul Wadon (in Warungbata village), Gajah Wong Educational Park (in Pandeyan village), situs Cinde Amoh and dam(in Giwangan village), funeral area of Old Mataram's king and Giwangan village (the cultural center village).

Giwangan Cultural Center Village have many cultural performance such as: Karawitan/Gamelan (Traditional orchestra), Wayang Orang (people puppet performance), Wayang Kulit (leather puppet performance), Ketoprak (Traditional drama life performance), Dance (Traditional, classic, modern), Jathilan (mystical dancing), Gejog Lesung (music of wood), Theq-theq (music of bamboo), Keroncong (traditional music), Campursari (traditional music creative), Mocopat (old wisdom poetry), Angklung (bamboos music), Dolanan Anak (children's games), Hadroh, Rebana, Samproh (moslem's music), Pit Onthel (ancient bicycle community), *Andong Wisata*, Batik handycraft, Silver handycraft, Varous Souvenirs (Bordir, Sulam Pita, Accesoris, Sungging Wayang, mini becak mini, etc), Culiner (various traditional food, various snack, jamu, emping mlinjo, abon nabati, etc). Unfortunately, the government does not handle the Gajahwong river community yet. The existency of community forum "Forsidas Gajahwong" and their activities attracts government's attention. One week Gajah Wong (14 – 21 April 2013), One day seminar Festival, art's and culture performance was done successfully. It is indicate that the people pays good attentions and willing to participate in developing Gajah Wong and the riverside area.

These attractive tourist spots can be developed as integrated eco-tourism.

Eco-tourism at the first defined by The Eco-tourism Society in the year 1990 as a kind of journey to the natural area that aimed to conservate the environment and for sustainability of social and culture of the local community. While The Australian

Department of tourism more or less defined eco-tourism as tourism based on nature within including the education aspect and the interrelation to the natural environment and the culture by managing sustainable ecology. It can be said that eco-tourism is a tourism managed by conservation approach. As the International Union for Conservation of Nature and Natural Resources means that conservation is men's effort to use the biosphere to achieve the bigger result and sustainability for this generation and in the future (Fandeli, 1990).

E. Policy to Perform Health River, Health Residential and Economic Growth

The government interested in fulfill the basics needs of the people. As there are many problems related to the housing and the residential area, in the year of 2011 Government regulate by The Governmet's Regulation Number 1 in the year of 2011 about Housing and Residential Area in point 56 (*Pasal 56 UU No 1 Th 2001 tentang Perumahan dan Kawasan Permukiman*):

1. Residential area organized in order to establishing land as living environment and space of activities to support comprehensive, integrated and sustainability living planned according to space arrangement.
2. Residential area organized as in point (1) aimed to fulfill citizen's right to get proper housing in health environment, secure, arranged and guaranty the certainty of residency

Riverside area in certain distance closer to the water along the river has main function as a bondary area between the river and the land. It is protected to maintain the sustainability of river functions and to control the environmental distruction of human activities (Chairman of Dinas PUP-ESDM DIY, 2013)

The eight criteria of health river are: 1) Have the sempadan area, 2) Rocks in the river's body, 3) Connections the beginning to an ends of the river, 4) Free from pollution, waste and garbage, 5) Amphiby access (water and land connection zone), 6) Fish, birds, and other species as ecosystem cycle, 7) No barrier for fish and other species water animal to do their activities and migration, 8) Have social access to the river

While the criteria of health residential area are: 1) As the order of Site Plan, 2) Outside of protected area, 3) Aware of living environment's condition, 4) Completed with public services such as proper access; clean water; domestic waste water disposal; garbage management; drainage and green open space

As Yogyakarta famous as tourist destination city, the economic growth strategy in Yogyakarta is by developing innovative programmes on tourism. Yogyakarta government developing Community Based Tourism concept which is offers the environmental resources and local way of life. Yogyakarta spirit "*Mamayu Hayuning Bawono*" has been guiding green development in Yogyakarta since in the year 1756 that modernized to develope Yogyakarta Green City. There are eight indicators of Green City namely: Green Planning and Design, Green Open Space, Green Community, Green Waste, Green Transportation, Green Water, Green Energy and Green Building. The development of integrated eco-tourism a Gajah Wong Riverside area must be conduct guidance by those government's policy.

F. Swot Analysis on Gajahwong River Integrated Eco-Tourism:

The data of Strengths, Weaknesses, Opportunity and Threats was collected by observation, focus group discussion, in-depth Interview, documentation and from National Seminar of Gajahwong Festival, 21 April 2013 in Yogyakarta. Based on the informations the SWOT (Strengths, Weaknesses, Opportunity and Threats) of Integrated Eco-tourism Development in Gajahwong riverside area shows as follow:

Strengths:

Source of the river water is from natural springs that have heritage value and watering 40.000 Ha ricefields, Yogyakarta Green Open Space 32,45% of area above the minimum standart (30%), Many tourist spots along the Gajah Wong riverside area, Strategic location in the city. Entrepreneurship of the people, many groups of various art and culture communities and economic activities, willingness of the people to participate in development.

Weaknesses:

Dirty river water, Untreated heritage springs (the river water source), No green knowledge, Low of managerial skill, Poverty, Less Capital, Minime Infrastructure, Illegal housing in the river lines, Regulation and Law enforcement.

Opportunities:

Government's support, Academician's support (UPN "Veteran Yogyakarta and Gadjahmada University), Groups of hobbies and economic activities in the area of study, River Community Forums, There are many Situs and Heritage, Yogyakarta towards Green City and the most famous tourist city.

Threats:

Dissaster, Global warming, Situs and Heritage destruction, Uncontroll Population growth, Global competition, Travel warning, Terrorism, Corruption.

G. The impact to National Resilience:

There are eight elements of national resilience called Asta Gatra, consist of Tri Gatra and Five Gatra. Tri Gatra is three natural elements of national resilience, there are Location and geographically position of the country, Natural Resources and Human Resources. Panca Gatra is five social elements of national resilience there are Ideology, Politics, Economics, Social- Cultural, Defense and Security. According to this concept hereby the condition that require to strengthen National Resilience by developing integrated eco-tourism in Yogyakarta:

Natural resources (land, water and natural wealth contained in it) well manage in sustainability and utilized largely for the people's necessity, Well educated people including in green knowledge to strengthen human resources, The implementation of National way of life (ideology) Pancasila in all aspect of development, Good governance and clean government, Grass roots democracy, Green business/ Green economic activities, The Sustainability of social and culture of local community and the national security protection.

Referring to the inter-related among gatra in National resilience, the growth of economic will impact to the increase of other gatra (in politic participation, social status, security etc). The contribution of Eco-tourism in strengthening National Resilience in the case of Gajah Wong integrated eco-tourism is the support to maintain sustainable development by the growth of economic to strengthen The National Resilience

CONCLUSION:

The development of Yogyakarta city to perform welfare for the people is depending on services sector rather than manufacture sector in big scale production. Yogyakarta as tourist city developing Community Based Tourism concept which is offers the environmental resources and local way of life. “*Mamayu Hayuning Bawono*” and *SEGORO AMARTA* guidance Yogyakarta towards Green city. Developing integrated eco-tourism along the Gajahwong riverside area, means all the potencies as a tourist spot will stimulate people empowering as a strategy to support local community economic development. Synergies with local government and other stake holder is needed to optimize and accelerate the progress of economic development in Yogyakarta. By integrating the potencial of nature, human resources and political will, this area is being developed as a business district based on ecotourism. The environment can be preserved, so people can also improve their living standards. By developing Gajahwong river and the situs and heritage surrounded, people can earn from it for living. Integrated eco-tourism along the Gajahwong river in Yogyakarta city will push the economic growth and other social aspects. The sustainable development will occur and the national resilience will getting stronger.

RECOMMENDATION

The recommendation of this research is that the synergy of five pillars namely Local Community, Local Government, Academician, Investor and National Policy is really needed.

1. Local community alongs the Gajahwong river must be eager to develop self resilience and participate in involvement with social and cultural or economic creative groups and maintenance the environment in the same time for sustainable development.
2. Local government should strengthening community and business leadership role in developing arts and culture and regulate people activities to maintenance the heritage.
3. Academician should participate more in finding the way out solving the problem that may appears with their capability in science and technology.
4. Investor (Government and Private investor) should keep on support the finance for arts, culture, creativity and design communities which is could be support by ventura capital, donator, sponsor, syariah bank and rolling funds from government

National Policy should be applicable and accelerate the synergy of the local community and the local government in developing integrated eco-tourism at the Gajah Wong riverside area.

ACKNOWLEDGEMENT

I would like to thanks to the organizing committee of the ICGAI for inviting and providing me this opportunity to present this paper. And also I would like to thanks to all my friends in FORSIDAS Gajahwong and the committee of Gajahwong Festival 2013 for the support and good friendship.

REFERENCE

- Carson, Rachel, *Silent Spring*, Houghton Mifflin, 1962
- Dobson, Andrew, “*Green Political Thought*”, <http://www.thehealingproject.net.au/wp=content/uploads/2009/ANDREW-DOBSON-Green-Political-Thought.pdf>, download, January 2012
- Government’s Regulation: *UU No. 7 Th 2004 tentang Sumber Daya Air*
- Government’s Regulation: *UU No. 26 Th 2007 tentang Penataan Ruang*
- Government’s Regulation: *UU No. 32 Th 2009 tentang Perlindungan dan Pengelolaan Lingkungan Hidup*
- Government’s Regulation: *UU No. 1 Th 2011 tentang Perumahan dan Kawasan Permukiman*
- Government’s Regulation: *PP No. 38 Th 2011 tentang Sungai*
- Government’s Regulation: *UU No. 13 Th 2012 tentang Keistimewaan DIY – Rancangan Perdais Pemda DIY tentang Tata Ruang*
- Fandeli, Chafid, Mukhlison, “*Pengusahaan Ekowisata*”, 2000
- Kimpraswil Yogyakarta, 2010
- Lemhannas RI, *Ketahanan Nasional*, 1999
- Payne, Dinah, M and Cecily A. Raiborn, “*Sustainable Development: The ethics support the Economics*”, *Journal of Business Ethics*, 2001
- Syamsiarini, Rani, 2013, Dinas PUP-ESDM DIY, “*Peran Pemerintah Dalam Pembangunan Kawasan Sungai Gajahwong*”, Seminar Nasional Lingkungan Hidup, Yogyakarta, 21 April 2013, unpublsh
- The Document of RPJPD Kota Yogyakarta 2005-2025
- The Ministry of Tourism’s Report, 2010
- Winarso, Setyo, 2013, Pengembangan Kawasan sebagai pendukung Kawasan Pemukiman yang berkelanjutan, Pusat Pengelolaan Ecoregion Jawa, Kementerian Lingkungan Hidup, Seminar Nasional, unpublsh
- [www. Businessdictionary.com/definition/field-research.html](http://www.Businessdictionary.com/definition/field-research.html)
- Yin, Robert K. 1989, *Case Study, Design and Methods*. Sage Publication. New Delhi.

PEOPLE EMPOWERMENT THROUGH GREEN WATER RESOURCES (STUDY IN GAJAH WONG RIVER)

Purbudi Wahyuni

^{1,2}Department of Management, Faculty of Economy, Universitas Pembangunan Nasional "Veteran"
Yogyakarta, Indonesia

purbudiwahyuni11@GMail.com

ABSTRACT

Water as the source of living and life has been regulated in 1945 Constitution of Indonesia Republic. It is state that "Land, Water, and all contained in it are used widely for the people's necessity". The capacity of government to serve the public facility constitutes to be the measurement of the development progress. As in the case of people living in the area of Gajah Wong river, they have not got good facility in fulfilling proper water for their consumption. Through the field research with data collecting by in depth interview, it is found a result that water from natural stream does not contain coli bacteria. While water from people's wells, in fact, contains coli bacteria. Anyway, the government has not shown its commitment to the natural streams, it is proved that the construction die down the natural streams, build up housing in the area of river, and also the low knowledge of the people about natural streams, even the streams that have heritage. The result can be used as a reference for the government in building up and educate the people through the increasing of added values to trees and educate people to look after the natural stream that have heritage values, so that the existing natural streams can be kept out as well as the condition of the surrounding of the green river and bring impact on the increasing economy of the people in the area of river Gajah Wong river.

Keywords: people empowering, green water resources, heritage, coli bacteria.

INTRODUCTION

Referring to the 1945 Constitution that has determines that "Land, Water, and Natural Wealth contained in it is taken charge by the state and are utilized largely for the people's necessity". Based on that statement, water used as the source of living and life, constitutes to be a very important necessity for human beings. It must be able to satisfy all people. However, until now, not all people can enjoy water that is proper to be consumed.

The statement above is in accordance with Winarso's statement (2013) that the majority of 32 large river in 30 provinces in Indonesia have not fulfilled the criteria of standard water quality for drinking water and at the same time it happens the river shallowness and narrowness. Furthermore (BLH DIY, 2012) stated that the quality of river water in Yogyakarta specially territory covering wining river, *Code, Gajah Wong, Konteng, Bedog, Tambak Bayan, Oyo, Belik*, entirely from the result of laboratory test indicates that BOD Clorin, Sulfur, Zinc, Copper, Coli Bacteria, and Coli total bacteria, show the result is more than quality standard. Particularly

Gajah Wong river, as the dirtiest one. Gajah Wong river as a river with the dirtiest river quality is wells which are in the area of Gajah Wong river nearly 80% as also having the quality far from standard quality.

It the necessary to know that the Gajah Wong river as a river with water debit merely come from natural streams, before the year of 2000, there were still about 49 natural streams, but in the year the existing natural streams have just about 24 (FORSIDAS Gajah Wong, 2013). Even among them, there natural streams that have heritage values, they are *Umbul Rojo* (Kingdom Stream), *Umbul Lanang* (man stream), *Umbul Wadon* (Women stream), *Umbul Naga* (King snake stream). The 24 streams that exist as the present time, it turn out that their conditions are poor. Based on the laboratory test done in Environment Engineering Department of UPN “Veteran” Yogyakarta, it show that water come from natural stream (24 streams) are state not contain coli bacteria and if the water debit is treated will it can supply the need of water of the local people.

That condition proves that until now not all people can utilize water that is proves for consumption. Water as the public facility is very important. Therefore, it become the task and obligation of the government with its policy to able to guard and to keep secure the of natural streams. The lack coordination inter governmental institutional bring about many development in the banks of river loosing or dying down streams, include the permission given to the developers who have now having the tendency to build up housing in the river area. Due to the low of control and punishment, there many developers who build up housing without paying attention to the conservations of environment.

Besides at the people’s understanding about the important of natural streams which it still law, make the commitment to keep the natural streams and the green river environment by not cutting the trees and throwing garbage into the river is still very law. Including the knowledge of the people in the area of rivers concerning with heritage value is also still low. As a matter of fact if this understanding has become their own, this potential will be able to increase their own, this potential will be able to increase tourism value.

For that reason, if there is an increase in the government commitment and the commitment of people in society, as well as the synergy between government and people, particularly in the area of Gajah Wong river in keeping the environment of river area, it will be kept the green environment and automatically it also will be kept the natural streams, so it will be obtained water debit in a very large amount and high heritage value. Now there is not eny attention from the government and from the people. It is hoped with the increasing commitment of the government and the people it will be able to empower the people in the are river, so it can rise the people’s welfare.

AIMS

It is aimed to know and to analyze the condition of the natural streams, as the solution of the sustainability of trees, and the optimalization of streams with heritage value as an effort to supply water that fulfills quality and quantity, so it can be a means to building awareness of the people to return the function and the benefit of rivers for the source of life and living, also as tourism icon which is green and clean.

METHODS

The researcher, who is also as the activist of the river (the second chairman FORSIDAS Gajah Wong/ Gajah Wong River Forum). The research design with the field research Data collecting with the indepth interview to key person from related river government institution, the people (chairmen area) who live in the near river Gajah Wong, in 9 village chief. Gajah Wong community (workers in Gajah Wong river), about government commitment and people commitment to optimalization the natural streams .further the data are analyzed descriptively.

RESULT AND DISCUSSION

A. The Commitment of Government in Supplying Water Quality and Quantity

Commitment is the relative strength of an individual's identification with and involvement in a particular organization. It is Characterized by a strong belief in, and acceptance of an organization's goal and values, willingness to exert considerable effort on behalf of the organization; and strong desire to maintain membership of the organization (Robbin, 2007).

The government commitment as the servant of the state, should have worked to give service to the society, let alone water has been the determination that is regulated in 1945 Constitution, that "Land, Water, and all contain in it used largely for the people is necessity". For that reason the government must have commitment, the government should have had the seriousness to pay attention to the quality and quantity of water as the source of life and living of the people.

Gajah Wong river which is located in the Region of Yogyakarta city, of course becomes the capacity of the government of Yogyakarta city to keep it well. That effort of the RPJM/Medium-Term Development Planning Program of Yogyakarta city to increase the health, and the acceleration of the development of basic infrastructure, including in it that relates to the supply of water that fulfiels the quality and quantity (RPJM, 2012). That is the increasing convenience and quality of social life of the people, and to try to low the level of water, land, and air pollution

.This determination is still far for what is felt by the people. As it is experienced by the people of Baciro village, with existence of the development of housing that against the river line. This condition results the trees in the area of river disappeared, the streams die down, the people who live in the northern side of the building get water pool if the rain season comes, even the water can sink them, as it is states by Joko Budi as the chairman of the zone one FORSIDAS Gajah Wong:

"Developers have got the permission by building housing, in fact the building is against the rule because they are build up on the line river, many trees are cut, even the foundation built die down the streams, because the building sticks out to the river, many of the people's wells are dried. The impact of this development, our area is always sinking when the rain comes, but the government until now there isn't any action. More shameful that those who live in that housing complex, most are the government stakeholders", government officials, they even give statement:

"Thank you for information, we will soon coordinated with the government of Yogyakarta City".

The statement until now is not yet any further actions, it is proved that Ulu-Ulu (the river guards) in Warung Boto area namely Oki Sulisty, gives information to the researcher that:

“Since April 2013 until now there isn’t any server of river area in the region, Mam. I that work everyday in this river has never got any attention related to the building of this housing that sticks out to the river and becomes the cause of the narrowness of the body of the rivers”.

The low commitment of the government, especially the culture office in creating the convenience and the quality of the people’s social life. One of them that happens in the region of Warung Boto, Umbulharjo district, Yogyakarta city. There is a historical site namely Umbul Raja (streams of Kingdom), with water debit included a great one, before 2000s, was still used as the source drinking water that is qualified, and used for swimming, taking bath and washing. But because there is culture and religion crash, this stream was clogged up by the people in the surrounding area and even it was blocked with cement, so that it does not produce water anymore. As a place that has high heritage value and has become the area of culture preserve, the government particularly culture office should be able to take action on this happening. This condition is in accordance with Mrs Umi Asih’s statement (second secretary of FORSIDAS Gajah Wong) that state:

“I am as the resident of Warung Boto, before the well was cemented, if I swam I always brought my children to swim in this little swimming pool, also if washing carpet I washed it here. The place is large, cool and the water was clean. This condition has been reported to Sultan as the governor and the King Ngayogyakarta Hadiningrat Place who has this area, in order that there is a respond. Thank’s God Sultan gave respond. It is prove that on June 10, 2013, he has talked to the local residents about the chronology of this Umbul (stream), and ather stream. And it begins to be responded and there is a further action that is the axisting of data collecting and and has been a signaling some Umbul a long Gajah Wong”.

Other happenings as a form of the low commitment of government especially (BBWS-SO/River Area Department Serayu-Opak) toward the effort to keep the low rate of water, land and air pollution. According to the law No. 32, 2009. It is state to the living environment media with the condition that fulfills quality standard of living environment and gets permission from Minister, Government, or Regent/Mayor according to their authority. Based on this law it means that the waste disposed to the river should have passed through the processing. But for Gajah Wong river, it is still necessary a very serious effort. It is proved that until now the rate of river water pollution is still high that brings an impact to well water of the people in the river area which is caused by industrial waste disposal, among them the waste of leather factory of Budi Makmur, Rejo Winangun village. Especially in the rainy season the water bedit is big and it is a chance for the factory to dispose its waste to the river. This condition is from the information given by Supriyanto, the river guard (Ulu-Ulu) of Gajah Wong:

“If the color of water is changing into black or blacker, when I inter the river, mu legs were icky and the fish I brought home, the fish is tasted as fried with cerocine”.

The proof that the government’s commitment to the quality and quantity of water is still low can be seen from the little budget allocated to rivers, as the source of water drinking of the people either through Water Drinking Company (PDAM) or streams for existence of people’s wells. This is seen from statement of the Head Budget Departement in Yogyakarta city :

“Gajah Wong river in the previously there was the limited budget, we will use by remembering priority and also aspect of even distribution”.

B. Increasing Awareness, Mental Attitude and Society Behavior in the Management of Natural Resources and the Sustainability of Living Environment Function to Keep the Convenience and Life Quality

The society as the receiver of benefit and that is the nearest with streams, should have high sense of responsibility toward the existing water needed. But in fact, there are many people of the society that involve in making the condition of rivers becoming very poor.

For the reason, the researcher who also as the resident of Gajah Wong river area, feels to be called to involve in trying to preserve the natural streams that brings impact to the utilization of the resident themselves. That's why the researcher with volunteer of Gajah Wong river made community that care river mediated by Budgeting Department in Yogyakarta City making FORSIDAS Gajah Wong on June 2012. In electing the organizer, the researcher got the mandate is Chairman II. Then coordinating with all the organizer, to find information immediately about how big the commitment of the people of river area to their environment, Among them concerning with natural streams. To get the information, it was agreed to hold animal festival. The first festival was done on April 14 until 21 with the theme "Diversity of Culture to be Hamemayu Hayuning Bawana" (how to keep the earth and all that contain in it order that this natural gives welfare to all human beings that live on it.

The efforts to realize the theme, FORSIDAS Gajah Wong does various activities, among them are:

1. Socialization to all people in the area of river, about the benefit of clean culture "Green and Clean" namely in 9 (nine) villages either in the city or in the region of Bantul Regency, since January 2013 to April 2013, the schedule of accomplishment. adapted with the meeting day in earth region. In every meeting, it is seen that the people who came are the representative of the amount of the local people. This shows that the people are willing to receive information and they are willing to share together.
2. Implementation of Mass Social Work, Social Work is done simultaneously along the Gajah Wong river, The enthusiasm of the people is very great. It is proved that not less than 5.000 personnel, starting from the young people until the old ones, involved in the mass social work held on Sunday 14th April 2013 beginning at 08.00 to 11.30. In this social work, it was agreed that taking garbage from the river, not throwing garbage into the river, supported by house in preparing the consumption. This condition shows that actually the people are willing to involve in looking after the environment.
3. Free fishing. This event was chosen to get information whether the people in that society were willing to come to the river. After the water of the river is full, it then spread out fish that were proper to be consumed, during three day simultaneously from 15, 16 and 17 April 2013 each was not less than 300 kilograms of fish to be spread out in three locations, exactly in the fourth, fifth and sixth dot, and fishing was permitted until April 2013, it turns out that with information of free fishing, it can invite public not only people who live in the area of Gajah Wong river but also fishing mania people from various regions. The fishing was free, but parking must pay, eating paid, so there was economic activities in the area of Gajah Wong river.

4. Taking data and Signaling streams, with the many streams disappeared it is necessary to hold data taking and signaling soon. This activity was done since Sunday 14 to April 20, 2013. In this activity it was found that there were 24 dots of streams, for of them have heritage value (including the history of the existing Ngayogyakarta Kingdom). From the 24 Streams, that have been done research by UPN "Veteran" Yogyakarta (2013) it was found the that those natural streams have quality and quantity that fulfill quality standard. But their condition until now is not paid attention even for the natural streams that have historical value. Due to the cultural conflict the condition of the streams are not treated well.
5. Various Competition (batik, coloring, drawing, tumpeng, and raffing)
6. The competition activities were held on Sunday 21 April 2013 beginning at 08.00 o'clock until 09.00 o'clock, in parallel, Through these various competition it was hoped that it could grow sense of belonging towards rivers particularly Gajah Wong river, Batik competition with the Batik motif with the theme "Gajah Wong River", was followed by University Students and residents. The competition was followed by nearly 500 Students and not less than 50 people. Coloring competition was followed by Kindergarten Students either from Yogyakarta, or even from Klaten, with the amount of competition participants about 70 students, Drawing competition was followed by Elementary Students from Elementary Schools of Yogyakarta City, there were around 50 participants "Tumpeng" competition was followed by 13 group of PKK (organization of wife), with not less than 90 house wives, even all the "tumpeng" were taken by the committee to give consumption to all the competition participants. This condition is to prove the existing sense of care to rivers. Further about "Gethek/ Raffing competition, the raffs were made of bamboo with the icon elephants and man the raff. It was hoped that by the existence of this competition the public could see move closely about the condition of water, on the condition of environment along the rivers.
7. Distribution of trees to grow the love to environment the committee distributed the seed of soursop trees to all the participants of the competitions.
8. Exhibition and Stands of UKM (Micro Business) Products. During the activities performed, there were many people to come of course they needed drink and food. This condition opened the business opportunity to the people surrounding the river.
9. Art performance. It was followed by the people from 9 villages along Gajah Wong river. This activity was done from 07.00 o'clock to 18.00 pm located at Mrican DAM (poll water) it a finish point of gethek/rafting competition. This competition was aimed to uplift the potency of region pure culture existing in the society in the area of Gajah Wong river, and it was hope that through art and culture it would befied in communication inter residents in the area of the river firmly.
10. Growing trees along the river. As one of the effort to make green the environment of the area of Gajah Wong river, all the participants of art performance were given "kenanga" trees to be grown/planted in there surrounding.
11. Releasing bird, is an indicator whether there is still shading trees as the bird habitat along Gajah Wong river.

12. Spreading Fish Seed, it is adapted with the type of fish used to be in the location, among than one fish called “wader Spat”, if the fish can breed, it proves that the water quality in Gajah Wong river increase and has fulfilled quality standard.
13. Discussion, this activity was don one Sunday, April 21th, 2013, from the 09.00 until 11.30 in Mrican RW 08 near DAM Mrican. Inviting the three core key the speaker namely from Ngayogyakarta Hadiningrat Kingdom related to the existence of Gajah Wong river as a heritage area (GBPH H Joyo Kusuma), The chief of the office government that is competent in natural resources field and water resources (Ir. Rani Syamsiarini, MT), and from stakeholders Yogyakarta Major (H. Haryadi Suyudi), followed by public communities along the Gajah Wong river and attended by not less than 150 people. The program was held to share together to get the best solution in developing Gajah Wong river and it area.

CONCLUSION

Remembering to the anthusiasm of the people in the area of Gajah Wong river and the participation to glorify the FESTIVAL, beginning from the socialization, working together cleaning the river, until the participation in discussion, also the existing attention from government in supporting the implementation of the activities. Show that the damage especially green water resources/natural stream in a long the river of Gajah Wong, due the lack of coordination between government and the society. Also the weakness of commitment of the government to sustainably give education to the people in the area of rivers that impacts to the existence of natural streams, and the low commitment of the government to educate the residents of the area of the Gajah Wong river continuously toward natural streams that have heritage value. It is hope with the existence of the activities that involve the two components namely the government and society through FESTIVAL sustainability became the means to being Yogyakarta city as green city so that it can be the life peacefully and well lovely.

REFERENCES

- Dhewanti, Laksmi. 2011. GREEN ECONOMY: Policy toward Sustainable Development in Indonesia. *Siminar Nasional “Industri Hijau untuk Masa Depan yang Ekonomis dan Berkelanjutan”*. Seminar Nasional Lingkungan Hidup.
- Hananto, 2013. *Program Pengembangan Kota Hijau (P2KH)*, Seminar Nasional Lingkungan Hidup. Kementerian Lingkungan Hidup.
- Harimurti, Bambang. 2011. *KEBIJAKAN PEMERINTAH DALAM PEMBERDAYAAN K-UMKM (KOPERASI, USAHA MIKRO, KECIL DAN MENENGAH)*. Seminar Nasional Pegembangan UMKM.
- Petranto, Ade. 2011. *Perkembangan isu green industry di perundingan unido, rio+20, UNCTAD XIII*. Seminar Nasional Lingkungan Hidup. Kementerian Lingkungan Hidup.
- Reksoprojo, Yono. 2011. *Sustainable Consumption and Production: KADIN Perspective. Jakarta National Seminar “GREEN INDUSTRY FOR ECONOMICAL AND SUSTAINABLE FUTURE”*. Seminar Nasional Lingkungan Hidup. Kementerian Lingkungan Hidup.

- Syamsiarini, Rani. 2013. *Lingkungan Hidup dan Masa Depan Bangsa*. Seminar Nasional Lingkungan Hidup. Tidak dipublikasikan.
- Winarso, Setyo, 2013. *Pengembangan Kawasan Sebagai Pendukung Kawasan Pemukiman yang Berkelanjutan*. Pusat Pengelolaan Ecoregion Java, Kementrian Lingkungan Hidup. Seminar Nasional. Tidak Dipublikasikan.
- Yin,Robert K. 1989. *Case Stydy, Design and Methods*. SAGE PUBLICATION. Newdelhi.

PROSPECT OF CLOVE LEAF BASED ESSENTIAL OIL INDUSTRY IN INDONESIA: A CASE STUDY OF DISTRICT SAMIGALUH KULONPROGO REGENCY

Juarini*, Ni Made Suyastiri YP.

Study Programme of Agribusiness, Agriculture Faculty,
University of Pembangunan Nasional "Veteran"
Yogyakarta

*Email : juarini_ma@yahoo.com

ABSTRACT

Essential oil is one of potential commodities in Indonesia. Essential oil is a natural extract of specific plant, either from leaf, flower, timber, or any other part of plant. Clove leaf oil is one of the essential oil types that is organized or produced by the people in Samigaluh District. KulonProgo Regency. This research uses descriptive method, while the research implementation uses case-study method located in Samigaluh District, KulonProgo Regency. Agro-industry clove leaf oil has a bright prospect because the potential market of this product is still widely opened especially in the world market where the demand volume continuously increases; the main raw material of clove leaf oil (dry clove leaf) is relatively easy to get in the dry season because the number of clove plantations in KulonProgo Regency is high enough and financially agro-industry clove leaf oil is very feasible to be organized

Keywords: Essential oil, clove leaf waste, business feasibility

INTRODUCTION

Indonesia has splendid assets of biodiversity. One of them is clove plant. Clove (*Syzygium aromaticum*, syn. *Eugenia aromaticum*) is a plant that can be utilized for the improvement of basic needs and quality of human life because almost all parts of this plant can be used directly or through production process first. Clove is one of the plantation sub-sector commodities mostly organized by public plantations. The main item of clove is its flower that is harvested when the petal is still folded. The main part of clove that has commercial value is its flower that is mostly used in cigarettes industry and only a small amount in food industry. However, recent inventions on the other parts of clove, its leaf and sprig have been utilized as oil resources.

Clove oil can be produced from its flower, sprig, or leaf. At the present time, the clove leaf that is considered as waste at first, through distillation process by using simple technology, can now produce essential oil that has economic value.

Clove has a huge amount of essential oil content, either in its flower (10-20%), twig (5-10%), or leaf (1-4%). The extract of clove leaf has the most economical value. Therefore, the type of clove oil that is commonly traded is clove leaf oil. Source: <http://achormohammad.wordpress.com/2011/10/25/industri-minyak-cengkeh-di-indonesia/>

Clove leaf oil is mostly used in pharmacy, perfume, cosmetics, and food and beverage flavor industries. The prospect of clove leaf oil in Indonesia is good enough, especially

in the clove production center. According to Balitro research report (2005), Java Island has ± 50.000 ha of clove plantation area, estimated to have falling clove leaves potential of ± 305 tons per day or equal to 4.4 tons of clove leaf oil per day. This estimation is based on the weight of falling leaves for each tree in the amount of 0.5 kg per week, the plant lifetime of more than 10 years, with the clove leaf oil yield of 2% to 2.8%, the plant population of 100 trees per hectare (poly-culture) and the average of canopy covering of 60%, will be a prospective business opportunity.

According to FAO data statistics, Indonesia is categorized as country with biggest clove oil production in the world and widest area of clove plantation in the world for about 241,800 ha or more than 70% of clove plantation area in the world. Several places in Indonesia that become the center of essential oil industry are Aceh Special Territory, North Sumatera, West Sumatera, Bengkulu, West Java, East Java, Yogyakarta Special Territory, Maluku, and East Nusa Tenggara. One of the essential oil centers in Yogyakarta Province is located in Samigaluh District, Kulon Progo Regency and has a business group of essential oil which consists of 13 (thirteen) small industrialists. Mostly, the essential oil that is produced is clove leaf oil. This clove leaf oil industry not only produces clove leaf oil as an export commodity that provides foreign exchange but also absorbs so many labors. Every business unit can absorb about 6 labors in the distillation unit and more than a hundred people as clove leaf gatherer. This clove leaf oil distillation industry is suitable for small and medium businesses because the raw material is relatively cheap and the process is simple.

Table 1 showed that the clove leaf oil export volume from the year 2000 until 2006 tend to increase. In this global market condition, the opportunity to develop clove leaf oil production in Indonesia is still widely opened. The potential of clove leaf oil in Indonesia is really good especially in the areas that are close to the raw material sources. At the present time, clove has been cultivated in almost all Indonesia area (Harris, 1990) so that the potential of clove leaf oil production business is great.

Table 1. The Development of Clove Leaf Oil Export Volume in 2000-2006

Year	Export Volume (kg)
2000	415,518
2001	429,300
2002	430,212
2003	442,333
2004	438,253
2005	448,858
2006	455,394

Source: Indonesia Essential Oil Board and IPB, 2009

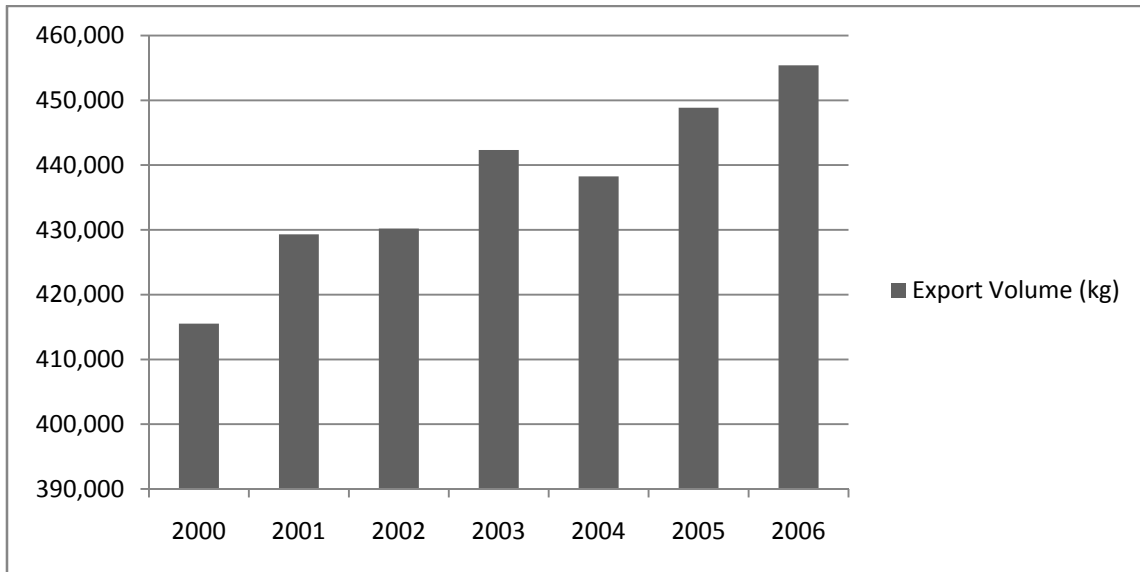

Figure 1. The Development of Clove Leaf Oil Export Volume (kg) in 2000-2006

Based on that phenomenon, this research is aimed to analyze the prospect of essential oil business using clove leaf waste utilization in Samigaluh District, KulonProgo Regency.

MATERIALS AND METHODS

This research uses descriptive method which is a method to analyze a group of people status, an object, and a set of condition, a system of thoughts, or a class of event at the present time. The objective of descriptive research is to make a description, portrayal or depiction in a systematic, factual, and accurate manner about the facts, the characteristics, and the relationship between the observed phenomena. (Nazir, 1989).

The research implementation uses case study method with the research location is in Samigaluh District, KulonProgo Regency where people run the business of essential oil distillation using clove leaf waste. There are 13 industrialists in Samigaluh District, KulonProgo Regency, DIY that perform the essential oil distillation using clove leaf waste.

A. Clove Leaf Oil

Clove leaf oil is the distillation result of dry clove leaf that has fallen, obtained through distillation process of dry clove leaf. Clove leaf oil has pale yellow color after it is distilled and easily change to brown or purple if it is affected by iron metal so that this oil is better to be packaged in a glass bottle, aluminium or tin drums. The essential oil of clove leaf quality is lower than the clove oil from clove sprigs. The distillation business is performed by the people with a simple technology using boiler from iron plate (plateser), hearth.

B. Prospect of Clove Leaf Oil

The market prospect of clove oil commodity is still widely opened either in local or foreign market. The demand on clove leaf essential oil is predicted to be continuously increased along with the increase of world’s population. The demand on clove leaf oil always increases and often goes beyond the limit so that it cannot be fulfilled by the production capacity of small clove leaf industries which are still limited.

In Kulon Progo area, the demand on clove leaf oil by the collector which is PT. Djasula Wangi at Solo, CV. Indaroma at Yogyakarta, and PT. Prodexco at Semarang. From the latest information, a huge amount of demand for a short duration usually organized collectively.

The clove leaf oil distillation industry not only produces clove leaf oil as an export commodity which is able to provide foreign exchange but also gives working opportunities for the local people to work as distillation worker and dry clove leaf gatherer. Along with the opening of market prospect, total area for clove plantations in Indonesia especially in Yogyakarta Special Territory, Kulon Progo Regency, and Samigaluh District increases as shown on table 2 below.

The total area of clove plantation industry that is increasing boosts the availability of raw material (clove leaf) so that the existence and the continuance of clove leaf oil distillation industry is guaranteed. If the deficiency of raw material from the local area occurs, then for the continuance of the distillation industry, the raw material can be brought from outside areas such as Bali, Sulawesi, and other clove production areas in Indonesia, but relatively higher in cost for sure.

Table 2. The Total Area Development of Clove Plantations in 2011-2012

Level	Total Area(ha)	
	2011	2012
Samigaluh District	1,224.3	1,276.35
Kulonprogo Regency	2,702	3,042
DIY	2,882	3,071
Indonesia	485,193	485,304

Source: The Department of Agriculture, Plantation, and Forestry of Kulon Progo Regency.

The price of clove leaf is much depended on the season. If the availability of fallen dry clove leaf is good, the price of clove leaf will be dropped, conversely the price of clove leaf will be raised if the availability of fallen dry clove leaf is lacking. The price of clove leaf is in the range of 900-1,250/kg. Here is the development of average clove leaf price per year in Samigaluh District, Kulon Progo Regency.

Table 3. The Development of Clove Leaf Price in Samigaluh District, Kulon Progo Regency

Year	Clove leaf price (Rp/kg)
2011	900
2012	1,100
2013	1,250

Source: The Department of Agriculture, Plantation, and Forestry of Kulon Progo Regency

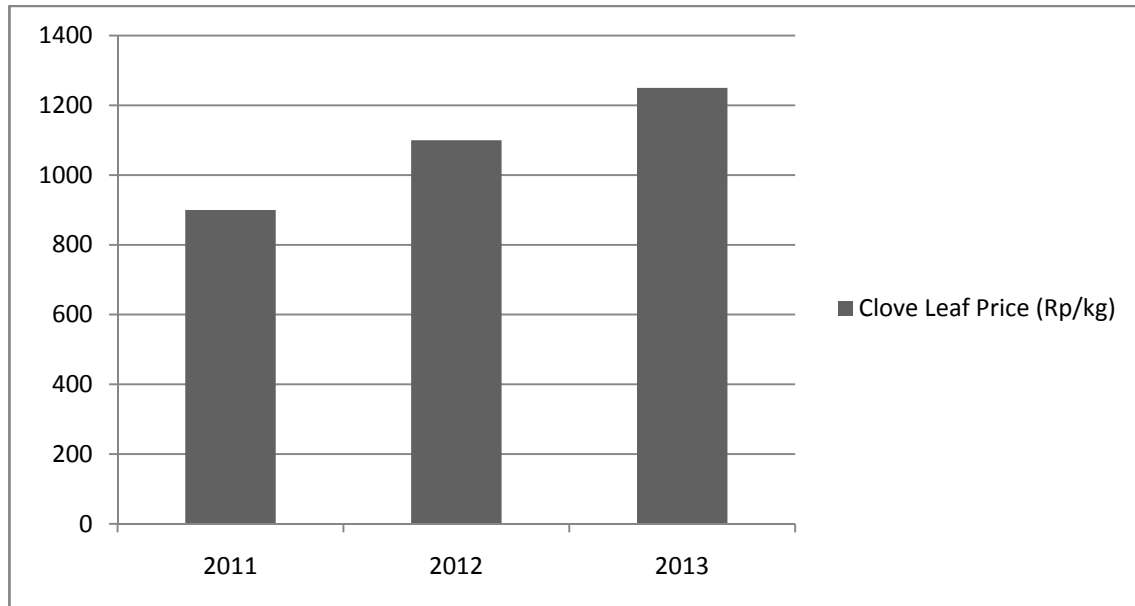

Figure 2. The Development of Clove Leaf Price in Samigaluh District, Kulon Progo Regency

C. Essential Oil Production (Clove Leaf Oil)

The optimum clove leaf oil production is depended on the boiler capacity that is used. Boiler with the capacity of 750 kg of clove leaf can produce approximately 20 kg of clove leaf oil. By using one boiler and two times of distillation process per boiler, it can produce 40 kg of clove leaf oil per day.

The quality of clove leaf oil that is produced by the clove leaf oil industries in Samigaluh District is influenced by: (1) the clove leaf raw material that is dry, clean, and not contaminated by other substance, (2) production process, (3) the condition of equipment that is used, and (4) the distillation process period.

A boiler which is made by anti-rust material will produce better clove leaf oil compared to distillation by using a boiler which is made by common iron plate or common tin drums. Shorter distillation period also influences the quality of clove leaf oil that is produced. The handling of production outcome also influences the quality of clove leaf oil that is produced. Clove leaf oil is supposed to be contained and kept in the package made from glass, plastic, or any other anti-rust materials. Its quality will be downgraded if it is contained only in the package made from rusted metal. Clove leaf oil is easily oxidized with material from metal.

The production of clove leaf oil in Samigaluh District is in the average of 3 tons/month and the production in 2012 reached 43,597.5 liters, with price continuously increases from year to year. More detail can be noticed from table 4 and figure 3.

Table 4. The Development of Clove Leaf Oil Price in Samigaluh District, KulonProgo Regency

Year	Clove leaf oil price (Rp/lt)
2011	112,000
2012	105,000
2013	115,000

Source: The Department of Agriculture, Plantation, and Forestry of KulonProgo Regency

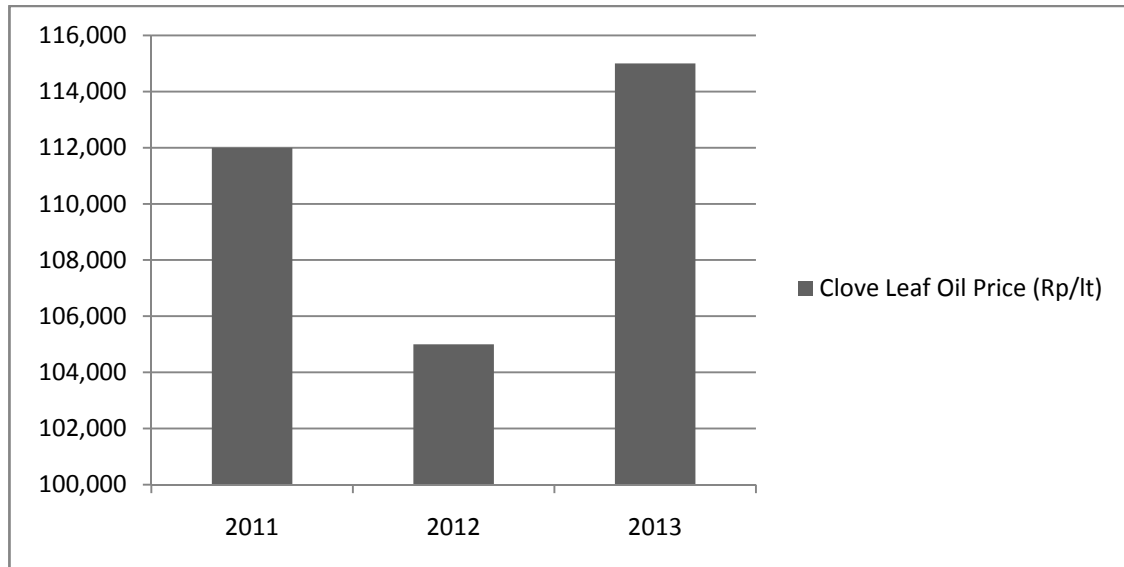

Figure 3. The Development of Clove Leaf Oil Price in Samigaluh District, KulonProgo Regency

D. Business Feasibility of Clove Leaf Oil

The prospect of clove leaf oil distillation industry is analyzed by using business feasibility analysis from the value of Internal Rate of Return (IRR), Net Benefit-Cost Ratio (B/C), and Net Present Value (NPV). Based on the research result by Bank Indonesia in 2004 on 22 small industrialists of clove leaf oil in Samigaluh District on discount rate of 18 percent, the IRR value obtained was 55.66 percent, implicating that this project is feasible up to 55.66 percent on the interest level. Net B/C ratio of 1.96 indicated that this industry is feasible (because Net B/C Ratio > 1). Then with positive Net Present Value of Rp 314,587,336.16, this industry is feasible to be in business. The projection result of clove leaf oil distillation business feasibility is shown on table 5.

Tabel 5. The Business Feasibility of Clove Leaf Oil Distillation Industr

Feasibility Criteria	Value
Internal Rate of Return (IRR)	55.66%
Net B/C ratio	1.96
Net Present Value (NPV)	Rp314,587,336.16

Source: Bank Indonesia, 2004

Sensitivity Analysis

Several scenarios are used to analyze the project sensitivity toward the assumption change of income and operational cost.

Scenario 1. Assumption that the business income reduces while its costs and any other components are constant. Income reduction occurs when there is a product reduction, price reduction, or consumer demand reduction.

Scenario 2. Assumption that the operational cost increases because of the increase of raw material price or the other equipments, while the income and any other components are constant.

Scenario 3. Combination of scenario 1 and 2, assumption that, at the same time, the income reduces and the operational cost increases.

Table 6. The Result of Business Sensitivity Analysis on Scenario 1

Feasibility Criteria	Income Reduces	
	19%	20%
IRR	18.38%	16.18%
Net B/C ratio DF 18%	1.01	0.959
NPV DF 18%	Rp 2,879,998.16	- Rp13,537,649.70

Source: Bank Indonesia, 2004

Based on table 6, it shows that on the first scenario with the assumption that the income reduces up to 19%, this clove leaf oil industry is still feasible to be in business. At time that the income reduces up to 20%, this industry is started to be not feasible to be in business.

Table 7. The Result of Business Sensitivity Analysis on Scenario 2

Feasibility Criteria	Operational Cost Increases	
	35%	36%
IRR	18.32%	17.13%
Net B/C ratio DF 18%	1.007	0.980
NPV DF 18%	Rp 2,423,931.76	- Rp 6,495,022.65

Source: Bank Indonesia, 2004

On the second scenario (Table 7), it shows that with the assumption that the operational cost increases up to 35%, this clove leaf oil industry is still feasible to be in business. However, when the increase of operational cost has reached 36%, this industry is not feasible to be in business anymore.

Table 8. The Result of Business Sensitivity Analysis on Scenario 3

Feasibility Criteria	Income reduces and operational cost increases	
	12%	13%
IRR	19.45%	16.06%
Net B/C ratio DF 18%	1.033	0.956
NPV DF 18%	Rp 10,898,352.06	- Rp 14,435,123.04

Source: Bank Indonesia, 2004

Table 8 (Scenario 3) shows that with the income reduction and the operational cost increases up to 12%, this clove leaf oil industry is still feasible to be in business, but in the income reduction and operational cost increase of 13%, this industry is not feasible to be in business anymore.

CONCLUSIONS

Agro-industry clove leaf oil in Samigaluh District, Kulon Progo Regency has a bright prospect because:

1. The market potential of clove leaf oil is still widely opened especially in the global market where the demand volume continuously increases.
2. The main raw material of clove leaf oil (dry clove leaf) is relatively easy to get in the dry season because the number of clove plantations in Kulon Progo Regency and its surroundings is high enough.
3. Financially agro-industry clove leaf oil is very feasible to be organized.

REFERENCES

- Bank Indonesia, 2004. Usaha Penyulingan Minyak Daun Cengkeh.
- Clive Gray, dkk. 2002. Pengantar Evaluasi Proyek. PT Gramedia Pustaka Utama, Jakarta.
- CV Java Multi Mandiri. 2013. Usaha Minyak Daun Cengkeh. <http://www.testers-kadar-air.com/usaha-minyak-daun-cengkeh/> Downloaded at July 16, 2013.
- Dewan Atsiri Indonesia dan IPB, 2009, "Minyak Atsiri Indonesia" [.http://minyakatsiriindonesia.wordpress.com/atsiri/](http://minyakatsiriindonesia.wordpress.com/atsiri/). Downloaded at July 16, 2013.
- Direktorat Jenderal Perkebunan. 2012. Luas Areal Cengkeh Menurut Provinsi di Indonesia, 2008-2012. <http://www.deptan.go.id/infoeksekutif/bun/BUN-asem2012/Areal-cengkeh.pdf>. Downloaded at July 16, 2013.
- Hansen Mowen, 2009. Akuntansi Manajerial, Penerbit Salemba Empat, Jakarta
- J. Price Gittinger. 1986. Analisa Ekonomi Proyek Pertanian, Penerbit UI Press, Jakarta.
- Kadariah, dkk, 1999. Pengantar Evaluasi Proyek. Fakultas Ekonomi Universitas Indonesia, Jakarta.
- Mamiel. 2013. Produksi Atsiri Cengkeh Kulon Progo Meningkat. <http://jogja.antaranews.com/berita/308800/produksi-atsiri-cengkeh-kulonprogo>. Downloaded at July 16, 2013.
- Mohammad, Achor. 2011. Industri Minyak Cengkeh di Indonesia. <http://achormohammad.wordpress.com/2011/10/25/industri-minyak-cengkeh-di-indonesia>. Downloaded at July 16, 2013.
- Mulyadi Pudjosumanto, 2002. Evaluasi Proyek. Liberty, Yogyakarta
- Nazir, M. 1989. Metode Penelitian, Ghalia Indonesia, Jakarta

Zulkarnain Djamin. 1993. Perencanaan dan Analisa Proyek. Lembaga Penerbit Fakultas Ekonomi Universitas Indonesia, Jakarta

THE ANALYSIS OF TECHNOLOGICAL CONTRIBUTION AND COMPETITIVENESS OF COKROTELA CAKE COMPANY YOGYAKARTA TO SUPPORT GREEN AGROINDUSTRY

Sri Wuryani*, Budiarto, Ani M. Nurhayati

Faculty of Agriculture, UPN "Veteran" Yogyakarta

* Corresponding author: wuryani_upn@yahoo.com

ABSTRACT

CokroTela Cake is the only company in Yogyakarta that produce various cakes made of modified cassava flour. There is no waste in the processing technology because the waste has been processed for feed production. Thus, CokroTela Cake Yogyakarta supports green agroindustry. The objective of this research was to analyze the Technological Contribution and Competitiveness of CokroTela Cake Company Yogyakarta. Descriptive method was used for this research. Respondents were determined by purposive sampling method. The methods involved observation, interview and distributing questionnaires to collect data, then data were analyzed by using Technometric Model. The model focused on assessment of four technological components, i.e. technoware, humanware, infoware and orgaware to compare their sophisticated, state of the art, contribution component and contribution intensity. These values were used to calculate Technological Contribution Coefficient (TCC). The company competitiveness was determined by using product innovation and productivity approach. The result of this research showed the highest contribution was humanware followed by infoware, orgaware and technoware, respectively. The TCC value was 0.684, thus, CokroTela Cake Yogyakarta was classified into a good and semi-modern competitive company.

Keywords: CokroTela Cake, technological contribution, technological component.

INTRODUCTION

The effort of promoting the use of local food such as cassava has been obviously practiced recently. The example of successful project is the use of mocaf (modified cassava flour). It is a cassava derivative product which is obtained by modifying the cassava cells fermentation, as food ingredient and wheat substitution on noodles, biscuits, cakes, and breads product (Achmad-Subagio, 2008).

The process production of mocaf is quite simple, similar with the production of common cassava flour but followed by fermentation process, thus that it only leaves cassava peel as waste.

Cokrotela cake which was built in 2010 is the only company that produces cake with 100% mocafas raw material in Yogyakarta.

Achmad-Subagio (2008) proposed in the matter of mocaf use that in order to produce optimal quality of cakes product, formula modification is needed. The modification that is applied at Cokrotela Cake is by adding more eggs than cake recipe in common (using

wheat flour). Thus, the process in Cokrotela Cake Yogyakarta only leaves cassava peels and egg shell. These wastes then can be used as feed raw material so that Cokrotela Cake Yogyakarta belongs to Green Agro-industry.

Cokrotelo cake product with variants such as pandan, chocolate, strawberry, blueberry, peanut, cheese, mocca, and bikaambon, is well-liked by the people because of its delectable flavor so that it becomes popular product as unique food souvenir from Yogyakarta (www.cokrotelacake.com).

This product is processed in the factory located in Jl. HOS Cokro Aminoto 97 and distributed through 6 outlets that are spread in Yogyakarta area. The combination of shape and cake flavour that suits the consumer taste with 100% local product as raw material is an innovation process that cannot be separated from the technology component touch and contribution so that it can contend in the competitive cake production in Yogyakarta. Meanwhile, the competitive advantage cannot be separated from the innovation of technology as artificial resource which is competitive and always developed (Gumbira-Said, 2001).

Technology estimation on agro-industry needs to be performed continuously because technology is one of the fundamental aspects to have a competitive power (Khalil, 2000). Evaluation of technology can be a bench marking towards the best industry (Lowe, 1995).

Based on the explanation above, the objective of this research was to analyse the contribution of technological component and competitiveness of Cokrotela Cake Company Yogyakarta to support green agro-industry.

MATERIALS AND METHODS

This research was performed in Cokrotela Cake Company Yogyakarta on August – November 2011 and the materials used were all components of technology which were involved in the process of cake production.

This research used descriptive method with selected employee as respondents that were determined purposively. Data were obtained from observation, interview, and questionnaire, and then analysed by technometric method to determine the technology contribution (UNESCAP, 1989). While the competitiveness is determined by using product innovation and productivity approach (Nazaruddin, 2008).

Technometric model is focused on the four technological components measurement so that it produces technological contribution coefficient (TCC) that can be used to determine the contribution classification and the technology level. (Sinaga, 2011). The four technological components are technoware, humanware, infoware, and orgaware that are correlated one to each other (Gumbira-Said et al., 2004). The steps of technology components contribution measurement according to Nazaruddin (2008) include:

1. The determination of technology components sophistication used value (score) ranged from 1-9; from this step, lower/L and upper/U limit value for each component will be obtained.

- The study of technology components complexity (state of the art = SOTA). In this step, ST,SH, SI, SO value will be obtained through formula:

$$\begin{aligned}
 S_T &= \frac{1}{10} \left\{ \frac{(\sum_{k=1}^{kt} kt)}{kt} \right\}; & S_H &= \frac{1}{10} \left\{ \frac{(\sum_{l=1}^{lh} lh)}{lh} \right\} \\
 S_I &= \frac{1}{10} \left\{ \frac{(\sum_{m=1}^{mi} mi)}{mi} \right\}; & S_O &= \frac{1}{10} \left\{ \frac{(\sum_{n=1}^{no} no)}{no} \right\}
 \end{aligned}
 \tag{1}$$

where:

ST, SH, SI, SO= SOTA components Technoware, Humanware, Infoware and Orgaware

k, l,m,n= criteria value on technology components level

kt, lh, mi, no = criteria amount on technology components

- The determination of contribution for each technology components by using formula:

$$\begin{aligned}
 T &= \frac{1}{3} (L_T + S_T (U_T - L_T)) \\
 H &= \frac{1}{3} (L_H + S_H (U_H - L_H)) \\
 I &= \frac{1}{3} (L_I + S_I (U_I - L_I)) \\
 O &= \frac{1}{3} (L_O + S_O (U_O - L_O))
 \end{aligned}
 \tag{2}$$

- The study of contribution intensity for each technology components. In this step, dual matrix from the questionnaire result is developed until β value is obtained for each component ($\beta_t, \beta_h, \beta_i, \beta_o$) by using Software Expert Choice.

From the four steps above, TCC is measured by using formula:

$$TCC = T^{\beta_t} \times H^{\beta_h} \times I^{\beta_i} \times O^{\beta_o} \tag{3}$$

While the measurement of competitiveness that is based on productivity uses formula:

$$\text{Multifactor productivity} = \frac{\text{output which is produced}}{\text{total input which is used}} \tag{4}$$

(Nazaruddin, 2008)

RESULT AND DISCUSSION

A. Analysis of Technology Contribution

1. The analysis result on the measurement of technology components sophistication level is showed by lower limit (L) and upper limit (U) value which are listed on table 1.

Table 1. Lower and Upper Limits of Technological Components

Components	Lower limit	Upper limit
Technoware	2	5
Humanware	6	9
Infoware	5	8
Orgaware	5	7

The sophistication levels which are presented on table 1 show that the lowest lower limit was technoware. This is related to the equipment used in the transformation process from raw material to product which is mostly manual so that the complexity level is low and only mixer which has specific function. While the highest upper limit was humanware component. This is apt with the fact that human resources especially at the management level has been already have innovation thinking on many kinds of production process idea or product diversity, and the innovation is actually exist on the wheat substitution into 100% mocaf so that it can produce cake product which is made from local raw material but has national/global reputation.

2. The analysis result by using formula (1) on the SOTA analysis for each component is shown on table 2.

Table 2.SOTA value of technology components

Component/Symbol	State of the Art (SOTA)
Technoware/S _T	0,792
Humanware/S _H	0,734
Infoware/S _I	0,797
Orgaware/S _O	0,914

State of the art (SOTA) is the measurement of complexity level from each technology component on the transformation process. It is shown on table 2 that the value of all of the technology components is above 0.5 meaning that the complexity level is good, as proposed in UNESCAP (1989).

3. The analysis result by using formula (2) on the measurement of Technology component contribution is shown on table 3.

Table 3. Technology Components Contribution

Component/Symbol	Contribution Value
Technoware/T	0,486
Humanware/H	0,910
Infoware/I	0,821
Orgaware/O	0,759

The analysis of technology components contribution is used to measure the contribution value of each component toward the technological component coefficient value, based on the formula that is used to measure the contribution value is much related to the technology components sophistication level.

As shown on table 3, the highest contribution is humanware. It means that human resources play an important role in the management of transformation process; this is apt with the technology sophistication data. The contribution of infoware is in the second place because in fact, the marketing information in CokroTela Cake company is very clear, through brochure, catalogue, or website, able to ensure the buyer/consumer that with 100% mocaf as its raw material, the product is good for health because of the antioxidant content which can prevent tumor or cancer.

Meanwhile, the information on the production process in the form of cake production SOP (Standard Operation Procedure) is very clear so that the quality control can be performed well. Based on the technology sophistication data, orgaware is in the third place because CokroTelaCake company is concentrated more on the stabilization of production process, has not reached the level of maintaining intensive relation with fixed buyer/relation/consumer. Technoware is in the last place of contribution possibly because of the production process equipment which is still dominated by manual equipment.

4. The analysis result, using Software Expert Choiceto, determine the technology components contribution intensity is shown on table 4.

Table 4. Technology Components Contribution Intensity

Component/Symbol	Value
Technoware/ β_t	0,405
Humanware/ β_h	0,377
Infoware/ β_i	0,080
Orgaware/ β_o	0,138

Inconsistency ratio = 0.08

Technology contribution intensity is developed based on the intensity level of one component towards other components. The result shows that there is inconsistency ratio that is a parameter to examine whether the improvement of intensity measurement by the management is consistent or not. If the inconsistency ratio $\geq 0,1$, it will be considered as inconsistency (the policy for technology component improvement is not consistent). Based on the inconsistency ratio = 0.08, the intensity improvement made by Cokrotela Cake management is consistent enough.

In the production process, equipment surely has high contribution intensity on the product, so that it has the highest intensity value. Either the humanware, its

contribution intensity is in the second place possibly because the human resources in the production process at the operator level has not been proficient enough to repair the broken equipment on their own so that the external backup is still needed.

Based on the humanware sophistication level, the operator is still at production level, has not reached the improvisation level yet.

5. The measurement of TCC value by using formula (3) is 0.684.

According to Saaty (1993) and Fauzan (2009) about the range of TCC value $0,5 > TCC \geq 0,7$, the result shows that the technology contribution is in a good classification and the technology level on the range of $0,3 > TCC \geq 0,7$ is considered as semi-modern category.

B. Competitiveness Analysis

The measurement result of CokroTela Cake productivity per month by using formula (4) is shown on table 5.

Table 5. Productivity real and target/ month

	Value (Rp)	Productivity
Output (real)	354.188.000,00	1,72
Input (real)	206.226.796,31	
Output (target)	342.450.000,00	1,66
Input (target)	206.006.496,31	

Table 5 shows that with productivity > 1 , CokroTela Cake is profitable. Because the real productivity is higher than the target productivity, CokroTela Cake is considered as Agro-company which has competitiveness. Considering from the technological aspect, competitiveness advantage cannot be separated from technology innovation (Gumbira-Said, 2001).

According to Michael E. Porter cit, Daryanto (2011), there are twelve pillar of competitiveness power, including technology alacrity and process innovation. Looking at the cake product which has utilized 100% mocaf, it is considered as an innovative technological process output and the idea from CokroTela Cake general manager/owner to utilize local food resources is very responsive in facing the technological change. Therefore, CokroTela Cake in Yogyakarta is categorized as competitive company.

CONCLUSION

- Based on the contribution value measured by technometric model, the highest contribution is humanware, followed by infoware, orgaware and technoware, respectively.
- Based on TCC value = 0.684, CokroTela Cake is classified into good and semi-modern technology level.

- c. Based on the real productivity and target productivity, CokroTela Cake is classified into competitive company.

REFERENCES

- Daryanto, A. 2011 Improving The Enabling Environment for Agribusiness and Agroindustry Competitiveness MB. IPB. Bogor
- Fauzan, A. 2009. Penilaian Tingkat Teknologi DOK Pembinaan UPT BTPI. Muara Angke Jakarta IPB, Bogor
- Gumbira- Sa'id. 2001. Penerapan Manajemen Teknologi dalam Meningkatkan Daya Saing Global Produk Agribisnis/Agroindustri Berorientasi Produk Berkelanjutan. Orasi Ilmiah Guru Besar Teknologi Industri Pertanian, FTP-IPB
- Gumbira-Sa'id, Rachmayanti dan MZ Muthaqqin. 2004. Manajemen Teknologi Agribisnis: Kunci menuju Daya Saing Global Produk. Penerbit PT. Ghalia Indonesia Jakarta.
- Khalik, T.M. 2000. Management of Technology. The Key to Competitiveness and Wealth Creation. McGraw Hill Book Co. Singapore
- Nazaruddin. 2008. Manajemen Teknologi. Graha Ilmu. Yogyakarta
- Porter, M.E. 2008. Competitive Advantage (Keunggulan Bersaing). Translation. Kharisma Publishing Group. Jakarta.
- Saaty, T. L. 1993. Pengambilan Keputusan bagi para Pemimpin. Translation Liana Setiono. Seri Manajemen No 134. PT. Pustaka Binaman Pressindo. Jakarta
- Sinaga, T.S. 2010. Manajemen Teknologi [http:// Tutisarma Sinaga. Wordpress. com.](http://TutisarmaSinaga.wordpress.com) accessed. December 1, 2011
- Subagio, A. 2008. Modified Cassava Flour (Mocal): Sebuah Masa Depan Ketahanan Pangan Nasional Berbasis Potensi Lokal. Rubrik. Teknologi Pangan Edisi No 50/XVII/Januari–Juni
- United Economic and Social Commission for Asia and Pacific (UNESCAP). 1989. Technology Content Assessment Bangalore : APCTT

EFFECT OF VARIETIES AND BLANCHING FOR MAKING COCOYAM (*Xanthosoma* sp) FLOUR AND FOOD PRODUCT

S.S. Antarlina and P.E.R. Prahardini

Assessment Institute for Agricultural Technology (AIAT) East Java

Jalan Karangploso Km 4 Malang, Indonesia

Email: antlina@yahoo.com

ABSTRACT

In Indonesia, cocoyam (*Xanthosoma* sp) is consumed in the form of processed foods in a simple, among others boiled / steamed, “getuk”, crisps and “perkedel”. In order to increase the diversification of processed cocoyam processed into flour, then flour cocoyam can be processed into a variety of food products. Bulbs purse like taro, but the basic purse shape tuber tuber child, the child is usually tubers are eaten. Bulbs purse sometimes give itching caused by calcium oxalate crystals are needle-shaped. Calcium oxalate can be reduced by steaming. The study aimed to determine the effect of cocoyam varieties and blanching the quality of flour and food products (cake). Factorial randomized experimental design, repeated three times. The first factor is 2 varieties purse (local Malang and local Lumajang) and long blanching (3) is without (0 min), 15 min and 30 min. Cocoyam flour processed by peeling, slicing, drying, milling / flouring and sieving. Then processed into flour cocoyam cake mix cake flour with as much as 50% wheat flour. Observed physical characteristic of cocoyam tuber, chemical composition analysis and organoleptic cake using Hedonic methods. Weight of tuber cocoyam Malang local varieties (226.26 g) is greater than the local varieties Lumajang (192.95 g). The yield of cocoyam flour of 31.43 to 34.85%. The chemical composition of cocoyam flour is the moisture content 9.55%, ash content 2.94%, 0.56% fat content, protein content 3.73%, crude fiber content of 2.21%, 60.08% starch content, and carbohydrate content of 81.05%. Organoleptic test results for cake made from cocoyam flour appear that it was well liked by the range of values 3.38 (fairly) -3.95 (like). Cake is preferably from Malang local variety, and blanching during 30 minutes.

Keywords: cocoyam (*Xanthosoma* sp), variety, blanching, flour processing, physical characteristics, chemical composition, food product

Paper of AIAT East Java presented at the Green Agro-Industry Investment For Our Future, on November 11 to 14, 2013 in Yogyakarta, Indonesia

INTRODUCTION

At this moment, fulfillment carbohydrates Indonesian society, largely sourced from rice and wheat. Dependency on both of those commodities is becoming a serious problem. Wheat is an imported commodity therefore its supply depend from foreign country, while rice fields as rice production land is narrowing because of building development. There dependency can be resolved by consuming local commodities as source of carbohydrate which is commodity from tuber crops. This is supported by government program in effort to face food vulnerability, launched Program Peningkatan Ketahanan Pangan (PKP), based on UU No. 7 Tahun 1996 about Food. Then the government issued Peraturan Presiden No. 68 tahun 2002 about Food Security, which is food consumption diversification development that relies on varieties of food source, institutional and local culture (Richana, 2012).

Tuber crops in Indonesia is very diversified, one of those is cocoyam (*Xanthosoma*). According to Richana (2012) that cocoyam consist of over 40 species, but only four of them harnessed which is *Xanthosoma violaceum* Schatt, *Xanthosoma sagittifolium* L. Schatt, *Xanthosoma caraceau* Koch, and Buoche. Yam flesh of *Xanthosoma sagittifolium* and *Xanthosoma caraceau* species is white coloured, while *Xanthosoma violaceum* and *Xanthosoma artrovireus* is yellow. In Bogor *Xanthosoma sagittifolium* is called talas belitung. Regional name for kimpul is mbote (Jawa Timur), lahun indung (Sunda), dilago gogomo (Sulawesi Utara), and new cocoyam (English).

Primary cocoyam beet form child beet, this child beet that is consumed, while for the primary beet is left there. Cocoyam sometimes give itchy feeling caused by needle shaped oxalate calcium crystal. Oxalate calcium can be reduced by washing using plenty amount of water, or by boiling.

Usage of cocoyam is still simple, which is become boiled, fried, or chips. If this cocoyam beet is still in simple processed form, soon there will be boredom of taste, therefore it needs another variation of processing. One of processed form of cocoyam is to be made flour which is half done material and long lasting. Then these cocoyam ingredients processed into other material, among them many variety of bread (sweet bread, cake, dried cake, etc), various type of noodle, and another product that uses flour. From Sunarti and Richana (2004) research, it turns out cocoyam flour can be made into cake bread, and even the expansion volume ($893,96 \text{ cm}^3$) is equal to those of cake bread from wheat flour ($670,43 \text{ cm}^3$).

Cocoyam flour is white coloured and slightly yellowish and depend on the colour of the cocoyam flesh, but commonly Indonesian cocoyam is white coloured. Cocoyam flour whiteness degree is 69,54, while if the flour making process is bisulfite then the whiteness degree increase to 77,75. Flour making process is relatively easy compared with starch. Starch process is difficult mainly when deposition because it contain glycoprotein that forms colloid. According to Richana (2012) cocoyam starch have small granule size and not homogen around 1—4 μm .

The objectives of the research is conducted to understand effect of cocoyam variety and time of blanching to the quality of flour and its processed products.

METHODS

Research is taken in Postharvest Laboratorium Assessment Institute for Agricultural Technology (AIAT) East Java in 2012. The research main ingredients is cocoyam (*Xanthosoma* sp), additional material is cake making material which is eggs, margarine, wheat flour, and sugar. Randomized design factorial (2 factor). Factor treatment I (2 level) is two cocoyam variety which is Local Malang and Local Lumajang, factor II is time of blanching for cocoyam (3 level) that is 0 minute (without blanching), 15 minutes, and 30 minutes. After blanching treatment (according to previous treatment) continued with the making of cocoyam flour (Figure 1).

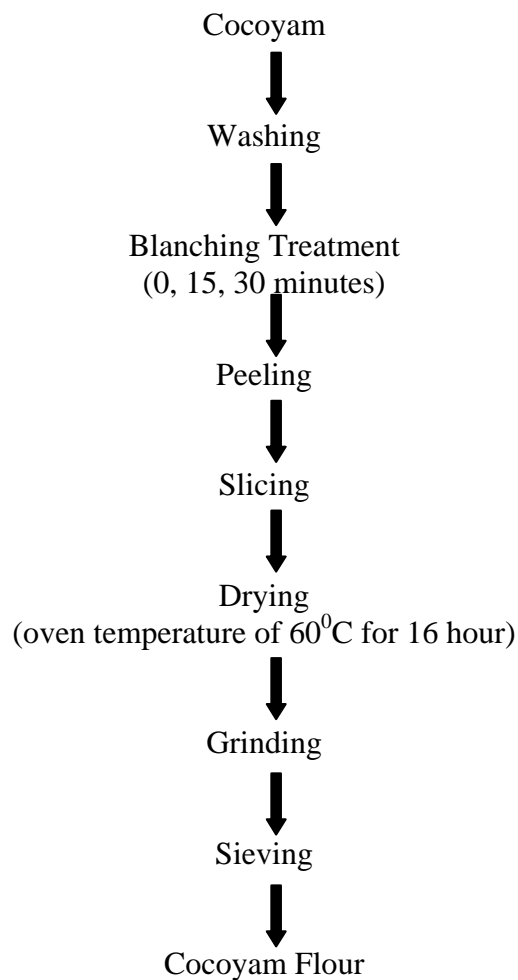

Figure 1. Stages of cocoyam flour processing

Next is these cocoyam flour made into cake, the making of cake mixture is 50% cocoyam flour and 50% wheat flour. Mainly the method of cake making is mixing margarine and sugar using mixer with high speed until it expand, add eggs, flour, ovalette, and baking powder. Insert into baking pan and put it into oven on 150°C temperature for 45 minutes. Observation is physical analysis of cocoyam, flour soaking, flour chemical analysis (AOAC. 1990), and organoleptic test of cake using Hedonic method.

RESULT AND DISCUSSION

A. Cocoyam Physical Characteristic

In Table 1 it appears that there is difference in several physical characteristic of cocoyam, ie the diameter of the base, the circumference of the tip, volume and density. Cocoyam shape in one variety or different variety is very diversified and irregular. The weight, length, and center diameter of both variety is not in any real difference. Even so, the weight of Local Malang variety cocoyam (226.26 g), volume (200.6 ml) and density (1.17g/ml), is on average bigger than those of Local Lumajang variety, weighing (192.95 g), volume (192.4 ml), and density (1.03 g/ml).

Table 1. Cocoyam Physical Characteristic

No	Characteristic	Local Malang Variety		Local Lumajang Variety	
		Average	Range	Average	Range
1	Weight (g)	226.26 a	153—331.78	192,95 b	101.93—333.83
2	Length (cm)	12.53 a	6.38—18.8	11,54 a	6.5—18.5
3	Diameter (cm)				
	- Tip	4.36 a	3.00—6.49	4,83 a	3.79—5.53
	- Center	5.64 a	5.17—6.46	5,50 a	4.82—6.37
	- Base	5.32 a	3.99—5.74	4,67 b	3.9—5.92
4	Circumference (cm)				
	- Tip	13.02 b	9.7—16.4	15,25 a	12.7—17.4
	- Center	17.56 a	15.7—19.6	17,56 a	15.2—20.4
	- Base	16.46 a	13.0—18.0	14,17 a	12.6—17.1
5	Volume (ml)	200.6 a	104—354	192,4 b	96—412
6	Density (g/ml)	1.17 a	0.94—1.47	1,03 b	0.81—1.25

Note: number accompanied by the same letter in each row describe there is no real difference in LSD 5%

B. Yield of Flour

Yield is the amount flour produced from the fresh cocoyam. Yield produced from two variety of different treatment (time of blanching) is no difference which is around 31.43—34.85% (Figure 2, 3 and 4). Sunarti and Richana (2004) research result, yield produced from cocoyam flour is around 23.43%. Yield of flour produced from few stages, which is blanching treatment, cocoyam skin peeling, slicing, drying, grinding, and sieving. These stages can affect yield of flour product. Stage that has the biggest influence is the peeling process. Cocoyam skin peeling is done manually using knife without machinery, therefore the thickness of the skin wasted is affected by the way the worker peel it. The thicker the skin wasted, the less the yield produced.

Dry sliced cocoyam grinded to produce flour using grinding machine, therefore influenced by the speed of the machine (rpm). After grinding comes sieving. The size of sieve hole (mesh) influence yield of flour. Sieving done manually making the result influenced by the worker. If sieving is done maximally the yield of flour produced is higher than sieving in shorter time.

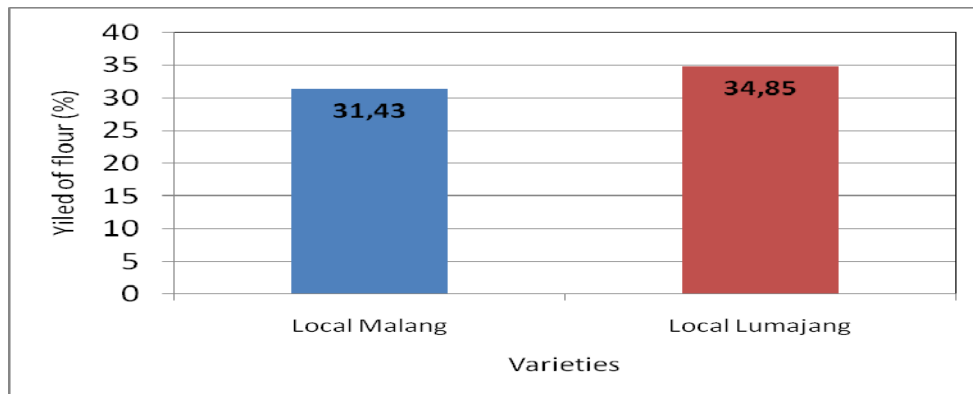

Figure 2. Two variety yield of flour

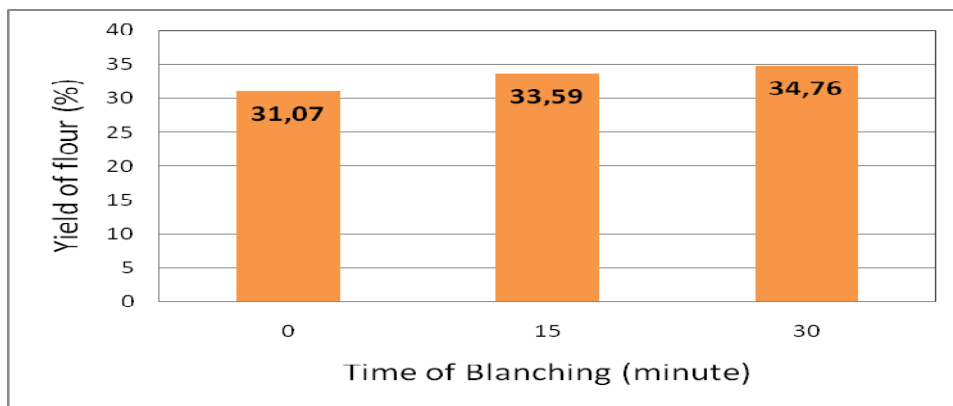

Figure 3. The effect of blanching

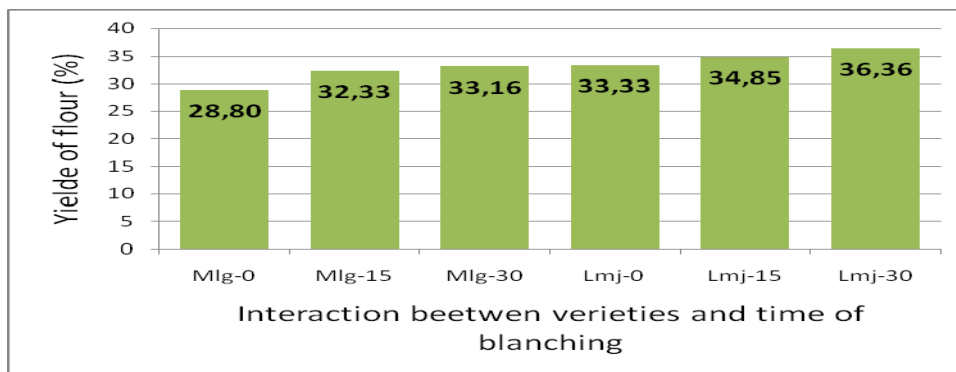

Figure 4. The effect of interaction

C. Chemical Characteristic of Cocoyam Flour

Chemical composition of cocoyam flour described in Table 2. It appears there is interaction between variety and blanching treatment. The moisture content of Local Malang variety is higher due to the longer blanching treatment while Local Lumajang variety the moisture content is lower in treatment without blanching. The difference in the moisture content is caused by the drying process. Cocoyam drying process stopped by manually observing the dryness level in sliced cocoyam flash, making it more

subjective. After analysis to the moisture content, there is a difference in moisture content in the cocoyam flour. According to Fellows (2000) steaming (blanching) caused change in cytoplasmic membrane in food tissue, therefore water will be binded by water soluble component and steamed from those tissue.

In treatment without blanching to the Local Malang variety, ash content (3.044%) of the flour is higher compared to Local Lumajang variety (2.771%). But the ash degree of Local Lumajang variety is highest in blanching treatment for 30 minutes which is at 3.024%. Thus the fat content of the flour have the same pattern with the ash content of these flour. Protein content, crude fibre, and starch on both variety shows that the longer the blanching treatment the higher the value.

As comparison to the chemical composition of cocoyam from research result of Sunarti and Richana (2004) is moisture content 6.2%, ash content 1.28%, crude fibre content 2.16%, protein content 0.69%, fat content 1.25%, starch content 70.73% and amylose content 16.29%.

Table 2. Cocoyam chemical composition on various treatments

Treatment	Composition (% wet basis)						
	Water	Ash	Fat	Protein	Crude Fibre	Starch	Carbohydrate
Variety							
- Local Malang	9.240 b	3.024 a	0.639 a	3.397 b	2.064 a	57.674 a	80.344 a
- Lumajang Local	9.857 a	2.811 b	0.480 b	3.987 a	2.327 a	62.478 a	80.500 a
Time of Blanching							
- 0 Minutes	9.500 a	2.908 a	0.640 a	3.144 b	2.109 b	51.600 b	81.698 a
- 15 Minutes	9.612 a	2.812 a	0.396 a	4.026 a	2.017 b	61.841 a	79.215 a
- 30 Minutes	9.535 a	3.032 a	0.641 a	3.905 a	2.461 a	66.788 a	80.352 a
Interaction = Variety x Time of Blanching							
- Local Mlg – 0 minutes	8.853 b	3.044 a	0.965 a	2.913 c	2.107 b	45.600 c	83.117 a
- Local Mlg – 15 mi	8.854 b	2.987 ab	0.461 bc	3.599 b	1.802 c	57.891 b	78.545 c
- Local Mlg – 30 min	10.015 a	3.039 a	0.491 bc	3.677 b	2.284 b	68.452 a	80.369 b
- Local Lumj – 0 min	10.148 a	2.771 bc	0.316 c	3.375 b	2.112 b	56.520 b	81.279 ab
- Local Lumj – 15 min	10.369 a	2.637 c	0.332 c	4.454 a	2.232 b	65.790 a	79.885 bc
- Local Lumj – 30 min	9.055 b	3.024 a	0.791 ab	4.133 a	2.638 a	65.124 a	80.335 b
CV (%)	6.23	9.53	70.10	10.64	16.56	13.60	3.84

Note : number accompanied by the same letter in each column describe there is no real difference in LSD 5%

D. Organoleptic Test of Cake

Organoleptic test to the cake described at Table 3. Generally cocoyam flour based cake (50%) with wheat flour (50%) is acceptable by the panelist. Cake colour is averaged liked with score 3.05-3.76 with criteria moderated to liked. Most liked cake colour is from the Local Malang variety with blanching treatment for 15 minutes.

Blanching treatment for 30 minutes, tend to increase score from panelist, which is more liked to the aroma, texture, taste and general appearance. More liked aroma such as in cake of Malang Local variety with blanching treatment scored 3,62 with liked criteria. That is because blanching treatment can remove of fusty aroma in cocoyam variety in general if flouring process is done.

Cake texture stated softer in blanching treatment for 30 minutes, in Local Malang and Local Lumajang variety. Soft texture is because the starch in flour had been gelatinization from blanching for 30 minutes, that is also affect the taste of cake that is

tend to more liked (more delicious). Cocoyam sometimes give itchy taste, caused by needle shaped oxalate calcium crystal. Oxalate calcium can be reduced by washing using plenty amount of water, or steaming and boiling (Richana and Sunarti, 2004). So it is understandable that blanching treatment for 30 minutes, the taste of the cake is better because there is reduction in itchy taste. Khamidah (2013) research result showed that itchy taste in kimpul yam can be removed by soaking the sliced beet in 7.5% salt solution for 25 minutes.

Table 3. Organoleptic test result in cocoyam flour cake in various treatment

No	Variety treatment-time of blanching	Colour	Aroma	Texture	Taste	General Appearance
A	Local Malang Variety					
1	0 minutes	3.67 a	2.81 c	3.81 ab	3.48 b	3.24 b
2	15 minutes	3.76 a	3.14 abc	3.19 d	3.48 b	3.48 ab
3	30 minutes	3.57 a	3.62 a	4.14 a	3.95 a	3.86 a
B	Local Lumajang Variety					
1	0 minutes	3.57 a	3.43 ab	3.24 cd	3.62 ab	3.48 ab
2	15 minutes	3.52 ab	3.43 ab	3.67 b	3.52 b	3.48 ab
3	30 minutes	3.05 b	3.05 bc	3.62 bc	3.38 b	3.29 b
	CV (%)	21.74	25.43	19.06	19.34	22.30

Note:

- The number accompanied by the same letter in each column describe there is no real difference in BNT 5%
- Organoleptic test evaluation:
 - colour, aroma, general appearance = 1 (very disliked), 2 (disliked), 3 (moderate liked), 4 (liked), 5 (very liked)
 - texture = 1 (very hard), 2 (hard), 3 (moderate), 4 (soft), 5 (very soft)
 - taste = 1 (very not delicious), 2 (not delicious), 3 (moderate), 4 (delicious), 5 (very delicious)

CONCLUSIONS

1. Local Malang variety cocoyam physical characteristic relatively bigger than Local Lumajang variety, each weighing 226.26 g and 192.95 respectively. Local Malang variety length is 12.53 cm and Local Lumajang 11.54 cm. Local Malang variety volume is 200.6 ml and Local Lumajang is 192 ml.
2. The yield of flour produced by each is 31.43% (Local Malang variety) and 34.85% (Local Lumajang variety).
3. Chemical composition is influenced by interaction between cocoyam variety (Local Malang and Local Lumajang) with time of blanching treatment (0, 15, and 30 minutes). The longer the blanching treatment the higher the protein, crude fibre, and starch degree on both variety (Local Malang and Local Lumajang).
4. Most liked cake is with blanching treatment for 30 minutes on both variety, with colour and aroma criteria moderate liked, soft texture, delicious taste, and general appearance liked.

REFERENCES

- AOAC. 1990. *Official Methods of Analysis of The Association of Official Analytical Chemists*, 14thed. Washington DC.
- Fellows, P.J. 2000. *Food Processing Technology Principles and Practice*. Woodhead Publishing Ltd, Enfield.
- Khamidah, A. 2013. Pembuatan Emping Kimpul Talas Belitung Sebagai Upaya Diversifikasi Produk Agroindustri. *Dalam* Peningkatan Daya Saing dan Implementasi Pengembangan Komoditas Kacang dan Umbi Mendukung Pencapaian Empat Sukses Pembangunan Pertanian. Prosiding Seminar Nasional Hasil Penelitian Tanaman Aneka Kacang dan Umbi Tahun 2012. Puslibang Tanaman Pangan. Bogor. 632—639.
- Richana, N, 2012. *Araceae dan Dioscorea: Manfaat Umbi-umbian Indonesia*. W. Waridah (Edt.). Nuansa. Bandung. 100 h.
- Richana, N. dan T.C. Sunarti. 2004. Karakteristik Sifat Fisikokimia Umbi dan Tepung Pati dari Umbi Ganyong, Suweg, Ubi Kelapa dan Gembili. *J. Pascapanen* 1(1): 29—37.
- Sunarti dan Richana, N. 2004. Pemanfaatan Tepung Umbi Minor Indonesia sebagai Tepung Komposit. Prosiding Seminar Nasional Peningkatan Daya Saing Pangan Tradisional. Balai Besar Litbang Pascapanen Pertanian. Bogor.

DIVERSIFIED FOOD PRODUCTS OF PUMPKIN (*Cucurbita moschata*)

Aniswatul Khamidah and SS. Antarlina

East Java Assessment Institute for Agricultural Technology (Indonesia)

Jl. Raya Karangploso Km. 4 Malang

Email : aniswatul.bptp@gmail.com

ABSTRACT

Pumpkin (*Cucurbita moschata*) contain high nutritional value at an affordable price so that it's have the potential to be developed into food products. Pumpkin contains many β -carotene or provitamin A which are beneficial to health. In addition, pumpkin also contains nutrients such as protein, carbohydrates, some minerals such as calcium, phosphorus, iron, and vitamins B and C. Fortification can be done by adding fresh pumpkin added to food products or can also by first processing pumpkin into flour which was then applied in to other food products. Food products from pumpkin flour have a specific color and flavor. However, the pumpkin has not been fully utilized. Many people are not familiar with the pumpkin's products. This paper aims to present opportunities pumpkin diversify into a wide range of processed products which can increase consumption and food diversity and economic value for the commodity pumpkin. Pumpkin can be processed into flour, nuggets, noodles, sweets (*manisan*) wet and dry, biscuits, flake, cake, *bakpao*, sauces, breads, brownies, candy jelly, crackers, chips, sticks, ice cream, jam, jelly drink, kuaci (It's like sunflower seeds) and *dodols* . Processed products can be applied by society because of simple technology and raw materials are easy to obtain. With the increasing consumption of pumpkin products, it will create jobs so that income and living standards of farmers cultivate and pumpkins processing industry will increase.

Keywords: processed, food diversification, pumpkin (*Cucurbita moschata*)

INTRODUCTION

Wheat needs in Indonesia continues to increase, the consumption of wheat in 2013 is estimated to reach 5.43 million tons, up 7% from last year's consumption of 5.08 million tons (Anonymous, 2013). Increased demand for wheat, among others, because of the increasing diversity of wheat-based food products. But the price of wheat is more expensive cause some wheat-based food industry to cut production. One solution to overcome this problem is to use local food to reduce the use of wheat. Pumpkin pasta or flour can be used to substitute the use of wheat in addition to increasing the nutritional value, especially vitamins and beta-carotene. In Indonesia pumpkin plant spread evenly throughout the region because of its cultivation techniques are very easy and very productive because every 1 hectare of land can produce 20-40 tons of yellow pumpkins. Pumpkin consumption rate in Indonesia is still very low less than 5 kg per capita per year (Noviasari, 2012). Pumpkin are plants in the family

Cucurbitaceae. Pumpkin plant consists of several varieties, both local and varieties that are imported from other countries for the purpose of development. An assortment of pumpkins is widely known among other things: 1. Pumpkin *bowl* type or types also called *Cerme*, 2. Pumpkin *snakes*, typically are long, slender fruit, yellow flesh color, weighing 1-3 kg (Sudarto, 1993). Pumpkin is a food that contains calories, carbohydrates, protein, fat, minerals (calcium, phosphorus, iron, sodium, potassium, copper and zinc), β -carotene, thiamine, niacin, fiber, and vitamin C, which protects the eyes (of attacks cataracts) and skin, immunity and reproduction. Pumpkin can serve as a vitamin A fortification in processed food products (Anonymous, 2012). Fortification can be performed by first processing pumpkin into flour or added in the form of fresh/pasta. Therefore it is necessary for processing pumpkin into diverse forms that can improve the taste of pumpkin product. This paper aims to present opportunities of pumpkin diversify into a wide range of processed products which can increase consumption and food diversity of pumpkins. This causes will result in increased value of pumpkin and economic value because it will create jobs, incomes and living standards of farmers cultivating and farmers who produce processed of pumpkin product. Moreover it will expect to improve nutrition community. Pumpkin can be processed into flour, nuggets, noodles, sweets (*manisan*) wet and dry, biscuits, flake, cake, bakpao, sauces, breads, brownies, jelly candy, crackers, chips, sticks, ice cream, jam, jelly drink, *kuaci* (it's like sun flower seeds) and *dodol*.

A. Harvest and Postharvest

In general, "local" pumpkin can already be harvested at the age of 3-4 months, whereas "*Genjah*" pumpkin can already be harvested at 40-60 days. Pumpkin superior or hybrid (example Japanese pumpkin) has to be learned at the age of 90 days. The signs of mature pumpkin such as it's have a hard skin, dry leaves/fall, plants become bald, stay rods. Harvesting is done with a knife/scissors are very sharp on the stalk, about 5 cm from the fruit, and then transported by covered with straw or grass to prevent friction between the fruit and the packaging. Fruits harvested done sorting, aerated in the open (so that hardened skin) and protected from the sun (Suprapti, 2009).

B. Nutritional Value Content Pumpkin

Yellow squash or pumpkin (UK) or ground pumpkin (Java) is a fruit of agricultural commodities are suitable to be developed as a bio-fortification of food products. Pumpkin has many benefits, including meat, seeds and leaves. Pumpkin meat contains a lot of β -carotene or provitamin-A, protein, carbohydrates, fiber, several minerals such as potassium, calcium, phosphorus, iron and vitamins B and C (Hendrasty, 2007). Pumpkin fruit weight average of 5-10 kg / fruit, but certain types of pumpkins can reach 30 kg/fruit and some even more. In addition to the fruit, leaves and twigs of young shoots are also very loved by the public as a material for vegetables. Another component of the pumpkin fruit still contains high nutritional value are seeds. Pumpkin seeds are high in fat so it is often used as watermelon seeds or simply fried for a snack. Pumpkin seeds contain a purgative laxative and anthelmintic that can be used for laxative worms. It also contains beta-sitosterol hormone (pressing the enzyme 5-alpha reductase), karboksifenilalanin, pirazolalanin, etilasparagin, stirulina, and amino butyric

acid, glycine, glutamate, Zn, Mg, phytosterols, omega 3 essential fatty acids (linoleic acid, acid oleic and linolenic acid bit), vitamin E and carotenoids. Pumpkin skin contains proteins (extracted to cope with fungi such as *Candida albicans* in humans, a type of fungi that cause infection (Noviasari, 2012). Comparison between the nutritional content of meat and leaves young twig is presented in Table 1.

Table 1. Meat Fruit Nutrition Pumpkin Yellow (100 g material)

No.	Nutrition	Content		Unit of element
		Meat	Leaves	
1.	Energy	29	30	cal
2.	Water	91,2	89,7	gram
3.	Protein	1,1	3,6	gram
4.	Fat	0,3	0,6	gram
5.	Carbohydrates	8,79	4,5	gram
6.	Calcium	45	138	mg
7.	Phosphorus	64	99	mg
8.	Iron	1,4	3,7	mg
9.	Vitamin A	180	2750	SI
10.	Vitamin B	0,08	0,14	mg
11.	Vitamin C	52	36	mg
12.	The edible part	77	70	%
13.	Sugar	6,6	-	gram
14.	Beta-carotene	3,43	-	mg

Source: Directorate of Nutrition Department of Health, Jakarta (1996)

C. VARIOUS PRODUCTS OF PUMPKIN

1. Flour

Flour is the intermediate product which can then be applied to processed products (noodles, bisuit, cake, ice cream, etc) as well as in the form of flour can extend the shelf life of raw materials and ease in storage. To make pumpkin flour must pass through seven stages, namely: Sorting, peeling, blanching, slicing, drying and flouring. Pumpkins consists carbohydrate such as starch, sugar, pectin, and cellulose. In the maturing process, the starch content decreases and sugar content will increase. Therefore, must be selected pumpkin fruit that mature but not yet ripe. Choose fruit approximately 5-10 days prior to the age of yellow pumpkins ready to be picked. The fruit is too ripe not suitable for flour made because of high water content and soft flesh so difficult to make dried chips, moreover it was already reduced starch levels so if forced to be flour, will only produce low-quality flour, the color becomes darker and it's have a low of yield. To get a pumpkin flour quality either, the skin should be peeled first. The next stage is blanching to prevent of browning on the fruit through the steaming of meat raw by using a pot. Pumpkin be cut so that steaming evenly process well, then blanching for 5-10 minutes, this process can maintain a pumpkin color. After blanching, pumpkins than have been chopped so small in size that are called chips, chip manufacturing can be done manually with tools such as knives. Measure the thickness of thin slices of pumpkin will affect the drying. Thick slices that are ideal from 0,1-0,3 cm. Slices that are too thick will require more drying time, while if it is too thin will dry faster when it is in the same drying conditions. Chip manufacture in large quantities can

use automatic chip maker tool. Chips must be dried, if the weather does not support, can use a dryer or oven at a temperature of 50-60⁰ C. Drying chips need special attention, because it will determine the quality of the flour to be produced. Maximum recommended moisture content 14%. If the moisture content is still high, the short shelf life and will reduce the quality of flour. Drying is carried out on the shelf, using a layer that is not corrosive such as bamboo or aluminum tray. Once dried, chip then milled by using a grinder Disk Mill type, size of 80 mesh (Astawan, 2004 and Plur, 2011). According to research (Rini, 2011) about the flour processing obtained that pumpkin flour yield of 10,49% with a carbohydrate content of 14,22%, protein 10,12%, fat 4,87%, 10,28% fiber and water content 11, 88%. Meanwhile, according to research Plur, 2011 levels of beta-carotene pumpkin flour 7,29 mg/100 g (Plur, 2011).

2. Nugget

Nuggets can be classified in restructured meat that is meat processing technique by utilizing a low-quality meat cutlet or utilize a relatively small and irregular, then be formed back into the larger size (Raharjo,1996 in Widati, et. al, 2009). Pumpkin as the fortification of beta-carotene and pro-vitamin A in nugget because generally nuggets have high in protein but low in vitamin A and beta-carotene so that fortification will enrich its nutritional. Pumpkin pasta added to materials such as milk, spices, bread and meat. Meat can be replaced with a mushroom that steamed first then finely chopped.

3. Noodles

Noodles are the most popular food in the whole country, it can be used as a food substitute for rice and need a short time to serve, so it is very popular (Nasution, 2005). The variety of noodle are 1)Wet noodles are noodles that been boiling process after cutting. 2)Fresh noodles are noodles that didn't undergo additional processing after cutting. 3)Dry noodles. 4)Instant noodles are dried noodles with addition of foods additive and ready to be served after cooking or boiling water brewed with a maximum of 4 minutes (Widyaningsih & Murtini 2006 in Singarimbun 2008). According to research Isnaini & Kusuma (2013), adding pumpkin pasta noodles 20% is most preferred with beta carotene 2,9 ug /g, water content 9,24%, ash 1,006%, 9,98% protein and carbohydrate 76,16%. Pumpkin noodles can fortified with soy flour to increase the protein content of noodles. Noodles with 10% soy flour substitution is the most preferred and the panelists would enhance the protein by 7,63% than those without the addition of soy flour. As in the study Ngantung, (2003) that soy flour noodles with the most preferred was 10% soy flour substitution that can increase by 7,63% protein.

4. Sweets (*manisan*) wet and dry

A wet sweets are served along with their fluid immersion and have a shorter shelf life than dry sweet which is about 5-7 days (with the food preservatives). In process wet sweets is obtained by product of liquid immersion. This fluid can still be processed into other products such as syrup, jelly, *dodol*, or as an immersion in the sweets next stage. Dried sweets has a shelf life of about 6-9 months. Sweets pumpkin yield was about 20%. Stage of making sweets is: pumpkin that has been cut, then dissolved in a solution of citric acid (15 liters of water in 200 g of citric acid) for 1-2 hours. After being washed, the pumpkin flesh soaked in lime milk solution for 1-2 hours (20 tablespoons in 20 liters of water, the clear liquid taken alone). Meat that has been soaked, washed and blanched 3-5 minutes. The next stage is immersion in a solution of sugar (50-55⁰Brix)

for 2x24 hours. From this case is obtained a wet sweets. Whereas to get a dry sweets, so the wet sweets generated further dried by oven or sunlight (Suprpti, 2009).

5. Biscuit

According to Smith (1972) biscuit is a thin pastry and crisp, with a low water content of less than 5%. Usually the formula biscuits such as fat, sugar, salt and materials developers. Biscuits can be divided into: 1) Hard biscuits; 2) Crackers; 3) Cookies and 4) Wafer. According to research (Igfir, 2012) processing of biscuits, showed that the most favored biscuit is the addition of pumpkin flour treatments: wheat flour (30: 235) g with water content of 3,33%, 1,61% of ash and broken power 0,0092 Nm/s.

6. Flake

Pumpkin as fortification in ready meals (flake) in the form of pasta and flour. According Herliana (2006), flake is one form of ready to eat breakfast in the form of thin sheets, shaped oval, tawny, a crisp texture and rehydration ability. According to research Khamidah&Ambarwati (2013) that the most favored pumpkin flake with pumpkin paste concentrate 50%. As for the pumpkin flour used for food fortification in cereals, the most favored received panelists at 1:1 (corn flour: pumpkin flour) with a water content of 5,3%, ash of 1,1%, protein 14,7%, fat 24, 7%, 9,5% crude fiber and 54,1% carbohydrate. The higher pumpkin flour, the less favored (Ramadhani et al., 2012).

7. Cake

Flour and pasta pumpkin can be used to make a cake. Cake is a bakery product besides icings, pies, cookies and sweet bread that fermented. Cake containing fat called butter cake, non-fat cake called a sponge cake. Materials commonly used in processing cake are egg yolks, egg white, sugar, wheat flour, butter, milk powder, baking powder and ovalet. Baking process includes the preparation of the dough, mixing, and roasting at a temperature from 163-204⁰C (Anonymous, 2001 in Suhardi & Antalina, 2010).

8. *Bakpao*

Bakpao can be made from pasta or pumpkin flour. Its processing by mixing material, low protein wheat flour, sugar, yeast, liquid (water/milk) and eggs. Mixing should be immediately stop if the dough is elastic. The long mixing make the less development than perfect buns. Salt and butter added after the dough is well blended because it will a clustered and bread dough will be dry because salt absorbs water (Purwadaria, 2011).

9. Sauce

Pumpkin can be used for substitution in the manufacture of tomato sauce, and even itself replace tomato as sauce with bright golden orange color, high content of β carotene. In anticipation of high prices in the tomato sauce, pumpkin is the best alternative to substitute tomato. Tomato sauce processing industry in Indonesia usually use tomato paste imported from Taiwan, as raw material to process sauce (Suyanti and Muhidin, 1990 in Dewayani & Darmawidah 2008). The absence of local tomato paste industry and the high price of imported tomato paste, cause tomato sauce prices in the market are expensive, so the substitution or replace tomatoes with pumpkin in sauce industry is very helpful in reducing import dependency.

10. Bread

Bread is a food product fermented flour with yeast or materials other developers, then baked (Mudjajanto & Yulianti, 2007). Bread available in the market are made from wheat flour and whole wheat (whole wheat bread). In making pumpkin bread, pumpkin flour just added as much as 10% of the overall weight of the flour. Adding too much flour will result in pumpkin bread can't inflate perfectly (Bogasari, 2010).

11. Brownies

Brownies is a bakery product, including the cake category. Brownies belong to the cake with a dark brown color and has a distinctive flavor dominant brown (Cauvain & Young, 2006). Brownies can be made from flour pumpkin and pumpkin pasta then mix the ingredients eggs, sugar, cocoa, flour, margarine, etc. and then steamed or roasted.

12. Jelly candy

Jelly is candy made from juice and gel-forming material which look clear transparent with certain chewy and texture. It's made by mixing pasta pumpkin with the materials commonly used of such as carrageenan, agar-agar powder, sugar, glucose syrup and citric acid (Anonymous, 2010). Pumpkins as fortification and natural dyes.

13. Crackers (*Kerupuk*)

Crackers is a type of dry food that contains high starch, made from tapioca because it has the greatest power to swell. Differences of raw materials or spices are added produce different types of crackers (Hartati, 2009). Processing of crackers include making dough, steaming, drying and frying (Yu, 1991, in Alami, 2006). Cracker dough can be in the form of solid (rice cake/lontong) which is then steamed, sliced and dried or with liquid batter is placed in a mold which is then steamed and dried. According to Parini research on pumpkin crackers, the most preferred of crackers is the composition of pumpkin crackers 250 gr, 200 gr tapioca flour, wheat flour 50 g with a value of 6,85% water content and 0,011 ug/g beta-carotene content (Parini, 2012).

14. Chips (*Keripik*)

Usually chips made by frying stage, but some are only through drying or even vacuum frying (Suyanti, 2010). Pumpkin chips using vacuum frying technology because water levels in pumpkin are very high. Vacuum frying temperature can be lowered to 70-85°C due to decreased oil boiling point. Thus damage the color, aroma, taste and nutrition can be avoided (Kamsiati, 2010). Vacuum machine capable of removing 85% of water content in the fruit and vitamins, minerals still be maintained. The working principle of vacuum frying is absorb the moisture content of materials at high speed so that the pores of the pulp isn't quickly close so the moisture content in the material can be absorbed completely. Ready chips are removed from the machine if the vacuum pressure between 68-72 cmHg than placed in spin machine (Saptoningsih & Jatnika, 2012).

15. Stick

Stick is a snack made from flour dough, shaped like a long stick than fried. Flour or pasta pumpkin used to make stick by adding wheat flour combined with various flour (tapioca, cassava, maize, tubers, etc.) eggs, butter and seasoning. The next batter was mixed until smooth and formed sheet. Next cut like sticks and fried (Khamidah, 2012).

16. Ice cream

Ice cream is basically a foam (gas dispersed in liquid) are preserved by cooling. Although the ice cream appears as a coherent entity, when viewed with a microscope would seem there are four building blocks, namely solids milk fat globule, air (whose size is no greater than 0,1 mm), small crystals of ice, and the water which dissolves sugar, salt, and milk protein (Ismunandar, 2004). Ice cream can be made from pumpkin pasta is added with ice materials (milk, ice cream powder, emulsifier and stabilizer).

17. Jam

Jam is a semi-solid made of a mixture of 45 parts by weight of fruit and 55 parts by weight of sugar (Anonymous, 2011). Jam can also be modified to jam sheet that more compact texture, plastic and non-sticky and it's more practical (Syafitri, 1992). Jam can be made from pasta and strands of pumpkin. According to Santoso et, al (2006) pumpkins consist of pumpkin pulp 73,83%, 4,05% seeds, rind 15,18%, and strands 6,93%. Jam is made by mixing pasta or strands pumpkin with thickeners, citric acid, margarine and sugar. According to research Yenrina, et al (2009) in the processing of sheet jam pumpkin strands, panelists liked the sheet jam pumpkin that the comparison of pineapple:pumpkin strand (80%:20%) with the water content 47,132%: 3,159% total acid; fiber 1,594%, 1,573% pectin; 25,929% sugar content and analysis of physical properties of the sheet strength test obtained of 1,866 N/cm².

18. Jelly drink

Drink jelly drink is a type of fruit juice were added carrageenan as a thickener and stabilizer. Making jelly drink and fruit juice is almost the same, just in a jelly drink added thickeners such as carrageenan. Mixing carrageenan and sugar should be homogeneous so that no lumps are formed which separates (Khamidah, 2012).

19. Kuaci

Kuaci from pumpkin seeds has advantages than a watermelon seed, watermelon seeds in addition to the hard-earned (nowadays people prefer seedless watermelon) as well as pumpkin seeds are larger and clearer color. According to research Suprapti (2009), pumpkin seeds that young age, not good for the quality of seeds. While pumpkin imports (giant melon) seed size larger than the local pumpkin. Watermelon seeds have a shelf life for 9-12 months. Processing of *kuaci* such as: pumpkin seeds after sorted, then soaked in a solution of chlorine (10 kg pumpkin seeds dissolved 20 liters of water + 80 g of chlorine) for 1 minute and then washed. After it soaked lime solution (the clear liquid taken alone) 20 tablespoons in 20 liters of water for 10 kg of pumpkin seeds for 2-3 hours. Seeds then washed and dried in the sun/oven. Seeds that have been dried, than boiled in a solution of salt until cooked. After cooked, than dried seeds (Suprapti, 2009). This pumpkin watermelon seeds yield 30%. Table 2 shows the seeds nutritional.

Table 2. Nutrition of pumpkin seeds/*kuaci* (each 100 g material)

No	Nutrition	Content	Unit of element
1.	Energy	515	cal
2.	Protein	30,6	gram
3.	Fat	42,1	gram
4.	Carbohydrates	13,8	gram
5.	Calcium	54	mg
6.	Phosphorus	312	mg
7.	Iron	6,2	mg
8.	Vitamin B	0,02	mg
9.	The edible part	9,9	%

Source: Directorate of Nutrition Department of Health, Jakarta (1996)

20. Dodol

Dodol made from pumpkin pasta with the addition of glutinous flour, brown sugar and coconut milk (Retnowati, 2006). *Dodol* is an intermediate moisture which has a water content of 10-40%; Aw 0,70 to 0,85; has elastic properties (Astawan & Wahyu, 1991). According to research Khamidah&Eliartati (2011) the process of making *dodol* is pulp of pumpkin then cooked with sugar and other food ingredients such as coconut milk and glutinous rice flour. Cooking is done until the maximum maturity in order to form a chewy texture of *dodol* (Yvonne, 1981 in Triwardhani, 2003).

D. Potential For Processed Pumpkin

Pumpkin has a high nutritional value, but its use isn't optimal. Problems arise when yields are very high and not all of them can be absorbed by the small industries. As a result, it will occur abundant harvests, so that needs a large storage space, consequently suffered losses because fresh pumpkin has a short shelf life. As an alternative to solving this problem is the use of pumpkins into a wide variety of pumpkin product so it can be utilized into another form that has a longer shelf life so it can be enjoyed at any time. Pumpkin is very potential to be developed because pumpkin cultivation technology are very easy and also very simple dairy technology processing, so it is suitable to be applied by small industries. However, the amount of production is not matched by its utilization. Pumpkin prices around Rp 5.000,- Rp 6.000,-/kg. However, if the processing is done, the selling price will increase as chips and sticks can achieve a price of Rp 30.000,- which is higher than the value of the benefits without being processed (Noviasari, 2012). Likewise, the pumpkins noodles benefits are enormous. Noodles price can reach Rp 22.000,-/kg. For candied pumpkin and *kuaci* represent a profit of Rp 168.500,- for each production process (Suprapti, 2009). Meanwhile, according to research Parini (2011) about the economic analysis of crackers, data showed that the results of the production capacity of 6.250 packaging/ month and the selling price is Rp. 4,000 / packaging, it will give net profit of Rp. 3.397.947,8 / month, Break Even Point (BEP) 4765 / packaging, Return on Investment (ROI) before taxes 16,32%, Return on Investment (ROI) after tax 15,81%, Pay Out Time (POT) 7 months, Benefit Cost Ratio (Net B / C) 1,16 and the Internal Rate of Return (IRR) 16,71% where the value is = 5% (BCA bank interest) stating that the company is worth to be developed as the B / C

more than 1. Pumpkin products to support food security because it can serve as a fortification of vitamin A in processed food products. With pumpkin exploited as vitamin A fortification ingredient for food products, so that it is expected to help solve the problem of vitamin A deficiency in Indonesia. To increase consumption of processed pumpkin, the one way is socialization of pumpkin processing technology, the nutritional composition and pumpkin products. Lack of public knowledge about product of pumpkin, make pumpkin hasn't been used optimally, so it is need socialization and training for the community. Beside that, it is need cooperation with industry/exporters to expand marketing. With this partnership, market certainty for products pumpkin can be guaranteed. Products pumpkin is more interested in the community because the community mindset is now beginning to turn to functional food. Beside the taste, the food consumed is also expected to contribute an additional nutritional value for health.

CONCLUSION

Pumpkin is a food that contains calories, carbohydrates, protein, fat, minerals (calcium, phosphorus, iron, sodium, potassium, copper and zinc), β -carotene, thiamine, niacin, fiber, and vitamins A, B and C. Pumpkin can be used both as a substitute and fortification of a wide range of products. Processing pumpkin is one way to increase the shelf life and reduce yield loss. If the harvest is abundant, pumpkin can be processed into powder form that has a long shelf life, practical and can be used for various other preparations. Beside the flour, pasta pumpkin can also be used for a variety of products. Assorted pumpkins processed products such as flour, nuggets, noodles, *manisan* (wet and dry), biscuits, flake, cake, *bakpao*, sauces, breads, brownies, candy jelly, crackers, chips, sticks, ice cream, jam, jelly drink, *kuaci* and *dodol*. This processed an expected to increase diversification and value-added processed products, the economic value for farmers cultivating and processing businesses pumpkin.

REFERENCES

- E. Alami.2006.Pembuatan Kerupuk Jagung (*Zea mays* L.), Kajian Penambahan Tepung Jagung dari Berbagai Varietas dan Konsentrasi Tepung Tapioka. Skripsi. Muhammadiyah Univ.
- Anonymous, 2010. **Permen Jelly**.
http://www.warintek.ristek.go.id/pangan_kesehatan/pangan/ipb/Permen%20jelly.pdf. accessible 30 Oktober 2012 pukul 08.57 WIB
- Anonymous, 2011. Selai Lidah Buaya. <http://bisnisukm.com/selai-sehat-lidah-buaya.html>. Accessible 26 April 2011 pukul 14:41 WIB
- Anonymous. 2012. Labu Kuning Kaya Gizi. 23-06-2012. accessible 18-06-2013, 11.02 WIB
<http://aceh.tribunnews.com/2012/06/23/labu-kuning-kaya-gizi>.
- Anonymous.2013.Konsumsi Terigu Diperkirakan 5,43 Juta Ton di 2013.www.neraca.co.id/harian/article/24301/Konsumsi
- Astawan dan Wahyuni, 1991. Teknologi Pengolahan Pangan Nabati Tepat Guna. Dalam Irawati, R,2001. Pembuatan Dodol Waluh (Kajian Penambahan Tepung Ketan

dan Terigu Serta Gula Pasir) Terhadap Sifat Fisik, Kimia dan Organoleptik. Skripsi Brawijaya Univ.

- Astawan, M. 2004. Pengolahan Labu Kuning. www.kompasCyberMedia-Gizi-Jumat 9 April 2004
- Bogasari.2010.Penggunaan Tepung Terigu dalam Pembuatan Roti. <http://www.bogasariflour.com>
- Cauvain, Stanley P dan Linda S Young. 2006. Baked Products : Science, Technology and Practice. Blackwell Publishing Ltd. Garsington Road
- Dewayani, W dan A. Darmawidah. 2008. Peningkatan Mutu dan Daya Simpan Pasta Tomat Dengan Cara Blanching. Jurnal Pengkajian dan Pengembangan Teknologi Pertanian Vol. 11, No. 3, Nopember 2008: 230-237
- Directorate of Nutrition Department of Health. 1996. *Daftar Komposisi Bahan Makanan*. Penerbit Bhratara Karya Aksara. Jakarta
- Hartati. 2009.Pemanfaatan Rumput Laut dari Sumenep untuk Fortifikasi Kerupuk Tapioka. Berita Litbang Industri. Vol.XLII, No.2.Nov pp44-52. Balai Riset dan Standardisasi. Surabaya
- Hendrasty, H.K. 2007. Tepung Labu Kuning, Pembuatan dan Pemanfaatannya. Penerbit Kanisius. Yogyakarta
- Herliana, S. 2006. Pengaruh Jumlah Air dan Lama Pengukusan Terhadap Beberapa Karakteristik Flakes Ubi Kayu (*Manihot esculenta Crantz*). Skripsi. S1-Fakultas Teknologi Industri Pertanian, Universitas Padjadjaran, Jatinangor, Sumedang
- Igfar, A. 2012. Pengaruh Penambahan Tepung Labu Kuning (*Cucurbita moschata*) dan Tepung Terigu Terhadap Pembuatan Biskuit. Skripsi. Hasanuddin University
- Ismunandar (Departemen Kimia FMIPA ITB). Dibalik Lembutnya Es Krim. Kompas, 3 Desember 2004. <http://www.kimianet.lipi.go.id/utama.cgi?artikel&1102121768&1>
- Isnaini, L dan Kusuma, I. 2013. Labu Kuning (*Curcubita Moschata*) Fortifikasi Vitamin A dalam Pembuatan Mie Kering. Prosiding Seminar Nasional. Pengembangan Ekonomi Kreatif Berbasis Komoditas Pertanian Di Indonesia. Universitas Sebelas Maret Surakarta.
- Kamsiati, E. 2010. Peluang Pengembangan Teknologi Pengolahan Keripik Buah dengan Menggunakan Penggorengan Vakum. Jurnal Litbang Pertanian. 29 (2). 2010
- Khamidah, A dan Eliartati. 2011. Pengaruh Penambahan Gula Pasir dan Gula Merah Terhadap Tingkat Kesukaan Dodol Nanas. Prosiding Seminar Nasional Pemandirian Pangan dengan tema Pengelolaan Sumberdaya Pertanian Mendukung Kemandirian Pangan Rumah Tangga Petani, Kerjasama BPTP JATIM dengan Fak Pertanian Univ Brawijaya, Kontak Tani Nelayan Andalan Pusat dan Dinas Pertanian Provinsi Jawa Timur. pp 387-392. Malang, 3 Des 2011.

- Khamidah, A. dan R. Ambarwati. 2013. Pengaruh Konsentrasi Labu Kuning (*Cucurbita Moschata*) Pada Pembuatan *Flake* Terhadap Kualitas Yang Dihasilkan. Prosiding Seminar Nasional dan Agrokompleks Universitas Muhammadiyah Malang.
- Khamidah, A.2012. Produk Olahan Lidah Buaya Menunjang Peningkatan Keanekaragaman Pangan. Prosiding Seminar Nasional. Perhimpunan Hortikultura Indonesia. Membangun Sinergitas Stake Holders untuk Meningkatkan Daya Saing Produk Hortikultura. pp 603-611.
- Mudjajanto E.S & L.N.Yulianti 2007.Seri Agrotekno Membuat Aneka Roti.Penerbit Swadaya. Jakarta
- Nasution, E.Z. 2005. Pembuatan Mie Kering Dari Tepung Terigu dengan Tepung Rumput Laut Yang Difortifikasi Dengan Kacang Kedelai. Jurnal Sains Kimia, Vol 9. No. 2, 2005:87-91
- Ngantung, M. 2003. Pengaruh Penambahan Tepung Kedelai Pada Tepung Terigu Terhadap Nilai Gizi Mie Basah Yang Dihasilkan. Jurnal Sains dan Teknologi. Desember 2003. Vol 3. No 3 : 110-118. ISSN 1411-4674.
- Noviasari, S. 2012. Labu Kuning Kaya Gizi. www.tribunnews.com
- Parini. 2011. Proses Produksi Kerupuk Labu Kuning. Tugas Akhir. UNS-Fakultas Pertanian Prog. D III Teknologi Hasil Pertanian. Surakarta
- Plur, N. 2011. Pembuatan Tepung Labu Kuning. Senin, 25 April 2011. Pukul 20.00. <http://www.doctortani.com/2011/04/pembuatan-tepung-labu-kuning.html>. accesible 18 Juni 2013,11.23 am.
- Purwadaria, dkk. 2011. Roti dan Pao-Kreasi Roti dan Pao Olahan Bogasari (Paduan Citarasa dan Seni Kuliner). PT Media Boga Utama.Gramedia. Jakarta
- Ramadhani, G.A., M. Izzati and S. Parman. 2012. Analisis Proximat, Antioksidan dan Kesukaan Sereal Makanan dari Bahan Dasar Tepung Jagung (*Zea mays*, L) dan Tepung Labu Kuning (*Cucurbita moschata* Duch). Buletin Anatomi dan Fisiologi. Volume XX. No 2. Oktober
- Retnowati, D. 2006. Pemanfaatan Terung sebagai Bahan Pembuatan Dodol. Skripsi Teknik Elektro , Fakultas Teknik, Universitas Negeri Semarang.
- Rini, V. I. 2011. Pembuatan Tepung Labu Kuning (*Cucurbita moschata* Duch). Skripsi. Universitas Pembangunan Nasional. East Java
- Santoso, U, Djamilah dan Gardjito. 2006. Karakterisasi Kimia, Fisikokimia dan Organoleptik Jam dan Jelly Jonjot Labu Kuning (*Cucurbita Maxima*). Jurnal Teknologi dan Industri Pangan. Yogyakarta
- Saptoningsih dan A. Jatnika. 2012. Membuat Olahan Buah. Agromedia Pustaka. Jakarta
- Singarimbun, A. 2008. Pengaruh Perbandingan Tepung Terigu dengan Tepung Jagung dan Konsentrasi Kalium Sorbat Terhadap Mutu Mie Basah (Boiled Nooddle). Skripsi. Departemen Teknologi Pertanian. Fakultas Pertanian. Universitas Sumatera Utara
- Smith, W. H. 1972. Biscuit, Crackers and Cookies Technology Production and Management. London : Aplied Science Publisher : LTD

- Sudarto, Y. 1993. *Budidaya Waluh*. Penerbit Kanisius. Yogyakarta
- Suhardi dan Antarlina. 2010. Pengaruh Tepung Kasava Dari Beberapa Varietas Ubikayu Terhadap Mutu Kue *Cake*. Prosiding Seminar Nasional Hasil Penelitian Tanaman Aneka Kacang dan Umbi-“Inovasi Teknologi Untuk Pengembangan Kedelai Menuju Swasembada”. 29 Juni 2010. ISBN 978-979-1159-48-7.
- Suprpti, L. 2009. *Teknologi Pengolahan Pangan*. Penerbit Kanisius. Yogyakarta.
- Suyanti. 2010. *Panduan Mengolah 20 Jenis Buah*. Penebar Swadaya. Jakarta
- Syafitri, E. 1992. Analisis Preferensi Konsumen untuk Penentuan Spesifikasi Produk Baru (Studi Kasus : Produk Selai Lembaran). Skripsi. Fakultas Teknologi Pangan IPB. Bogor
- Triwardhani, Y.R. Pengaruh Proporsi Rumput Laut (*Eucherma spinosum*) dengan Tepung Beras Ketan dan Lama Penyimpanan Terhadap Kualitas Fisik, Kimia dan Organoleptik Dodol Rumput Laut. Skripsi. Universitas Brawijaya. Malang
- Widati, A. S., E. S. Widyastuti and Sunarti. 2009. Pengaruh Tingkat Penambahan Tapioka dan Natrium Bikarbonat (NaHCO₃) Terhadap Kualitas Fisik, Kimia dan Mutu Organoleptik *Nugget* Daging Kelinci. *Jurnal Ilmu-Ilmu Peternakan*. Brawijaya Vol 19. No. 1, April. Brawijaya Univ
- Yenrina, R., N. Hamzah dan R. Zilfia. 2009. Mutu Selai Lembaran Campuran Nanas (*Ananas Comusus*) dengan Jonjot Labu Kuning (*Cucurbita Moschata*). *Jurnal Pendidikan dan Keluarga UNP*, ISSN 2085-4285, Vol. 1, No. 2, Agustus

FRESH CALYSES AS HEALTH DRINK FROM ROSELLE CULTIVATION IN POLYBAGS UTILIZING OPEN SPACES AT HOME

Sugeng Priyanto and Wahyu Widodo

Department of Agrotechnology, Faculty of Agriculture, Universitas Pembangunan Nasional "Veteran" Yogyakarta, Indonesia

Email: sugeng.priyanto@upnyk.ac.id

ABSTRACT

Roselle when fruiting, look beautiful and gorgeous as its sheath called red calyces, more impressed as interest, because the shape and structure are cupped upward covering the fruit pods. Herbaceous stems are also red contrasts with the leaves green. Roselle now commonly planted as an ornamental plant around the houses to take advantage of existing open space by grown in the ground or planted in pots. The beauty of this herb is increasingly prominent, if planted densely to form colonies. Besides beauty derived from Roselle cultivation around the houses also serves as a provider of fresh calyces to make health drinks that taste sour, which comes from a sense of itself calyces. As the risk of crop cultivation around the home stay is like plants shaded by something then can not get full sunlight during the day, but this plant requires full exposure though Roselle is a short day plant. To determine the intensity of sunlight resistance and also the suitability of the amount of growth media for growing as houseplants, then held a Roselle cultivation experiments which were grown in a variety of sizes polybag, and also shade with shading net from various levels of the percentage inhibition of light. At the end of the experiment the result was that Roselle in its growth requires a great growing medium and gets full sun exposure.

Key words: Roselle cultivation, fresh calyces, health drinks, ornamental plants

INTRODUCTION

Roselle (*Hibiscus sabdariffa* Linn) is a herbaceous plant which its estimated come from East India which then spread widely to the tropics and sub-tropics including Indonesia. The plant has two varieties with different cultivation purposes, namely first *Hibiscus sabdariffa* var. *altissima* is Roselle with yellow calyces which has been developed to take the trunk fiber as raw material for pulp and burlap sacks. The second is *Hibiscus sabdariffa* var. *sabdariffa* is Roselle with red calyces, now cultivated for its calyces taken as a useful raw material for drinks human health.

Roselle plant var. *altissima* can reach a height of 3-5 meters, bear most of the year, while var. *sabdariffa* plant height does not exceed two meters and the figure of the plant is a shrub. Rosella fruit var. *sabdariffa* looks very attractive because of the bright red calyces, some are even dark red. In Indonesia, Roselle plant has been known since 1922 that Roselle has flourished along the path of a train in Indramayu, West Java.

After many years known as a wild plant which was ignored, now the plant is known to many properties that are beneficial to humans from its calyces, so much cultivated again as an ornamental plant was carried around the home stay.

Calyces known to contain a variety of elements in each 100 g fresh weight, water as much as 86.2%; 44 cal calories; 285 IU of beta carotene; 11.1 g carbohydrates, 2.5 g fiber, 1.6 g protein, 1.0 g ash, 0.1 g fat; 160 mg calcium, 60 mg phosphorus, 14 mg of vitamin C; 3.8 mg iron, 0.5 mg niacin, 0.6 mg of riboflavin; 0.04 mg thiamine. That is adequate nutrition to meet the needs in maintaining body fitness.

As a consequence of the cultivation of plants around the home stay is limited space to grow and the shade was not intentional, so the intensity of sunlight is blocked which is required by the plant. So to find out due to the limitations it is necessary to investigate the inhibitory effect of light intensity and the magnitude of the planting medium on growth and yield of Roselle.

RESEARCH METHODS

To conduct research on the effect of the inhibition of light intensity and magnitude of growth media on the growth and fruits yield of Roselle plant prepared in the form of equipment, poly-bag, shading net, Roselle seeds, garden soil as a growing medium, and farming equipment in a pot that includes a small shovel soil, watering buckets, plant scissors, space around the house and or an open yard to put plants poly-bag.

The research took place in Kledung, Kradenan village, sub-district Banyu Urip, Purworedjo district, Central Java province, Indonesia from April to July. High research site is 18 m above sea level. To conduct the study, the experiment was prepared with the split-plot experimental design with the main plot as the intensity of sunlight that consists of three levels namely 100% of sunlight intensity (I_0); 55% of sunlight intensity (I_1) and the intensity of 25% sunlight (I_2). The sub-plot is the magnitude of the poly-bag which also consists of three levels, namely poly bag size (30x50) cm (K_1), poly-bag size (40x50) cm (K_2), poly-bag size (50x50) cm (K_3), which in turn, each sub-plot repeated three times so overall there are 27 sub-plot experiments. Each sub-plot consisted of 6 trials poly-bag plants.

To prepare for the experiment, the yard is divided into three equal parts wide to serve as the main plot. One part to get full sunlight, while the other two sections on above at 3 meter high mounted shade of shading net for blocking sunlight by 45% and 75%. Above each main plot of land then placed three kinds of size poly-bag plants as sub-plots which each represented by six kinds poly-bag plants.

DISCUSSION

In this experiment, the first observations at what age roselle plants start flowering and number of fruits per plant were produced, after the plant reaches the age of three months. From the observation, the age of roselle plant starts flowering was very influenced by the intensity of sunlight and the amount of growing media materials in polybag as shown in the following table.

Table.1: Age roselle plants start flowering (days)

Treatments	K ₁	K ₂	K ₃	Averages
I ₀	51.90	51.00	50.80	51.20 b
I ₁	52.30	52.20	51.70	52.10 ab
I ₂	53.40	52.70	52.80	52.90 a
Averages	52.50 p	51.90 pq	51.70 q	74.30 (-)

Note: The value of the average rate on the inter-column, and or between rows, which are given the same letter indicates no significant difference based on Duncan's Multiple Range Test. Sign (+ / -) indicates the interaction real / unreal between treatments.

From Table.1 it can be seen that the intensity of the sun's rays 100%, showing the average age begin flowering, shorter than the other solar radiation which is less than 100%. Similarly, from a large polybag, showing the average age begin flowering shorter than the others, which is smaller polybag.

In the calculation of roselle fruit production, as a continuation of flower production, showed the results were worth it, which is influenced by the intensity of sunlight and the large volume of polybag as shown in the following table.

Table.2: Number of fruits per plant

Treatments	K ₁	K ₂	K ₃	Averages
I ₀	16.30 b	19.10 ab	20.40 a	18.60
I ₁	6.00 c	7.10 c	6.10 c	6.40
I ₂	6.10 c	4.80 c	5.00 c	5.30
Averages	9.50	10.30	10.50	10.10 (+)

Note: The value of the average rate on the inter-column, and or between rows, which are given the same letter indicates no significant difference based on Duncan's Multiple Range Test. Sign (+ / -) indicates the interaction real / unreal between treatments.

From Table.2 it can be seen that the roselle plant, which gets sunlight intensity 100%, showing the average number of fruits per plant more than the plants that received solar radiation that are less than 100%. Similarly, plants in large polybag, showing the average number of fruits per plant more than plants with smaller volume polybag.

CONCLUSION

This experiment conducted in the period from April to July in Java which belonged to the southern hemisphere; in this period coincides with the dry season wherein the position of the sun shifts of 0 degrees latitude of the equator on March 21, towards 23.5 degrees northern latitudes reached on June 21, and then shifted back to the equator on September 21. It was also shown that the area south of the equator are experiencing short periods of sun exposure. Roselle in this study, flowering, which later became the fruit; since roselle are short day plants are having an appropriate situation. From observations began flowering plant age, and the amount of fruit produced per plant, showed good results are the plants get full sun intensity with most growing media. Therefore, if the roselle used as ornamental plants at around homes and to get a lot of

calyces, well if planted in a position to get full sunlight all day. As for the nutrient needs can be done with intensive fertilization with organic fertilizers.

ACKNOWLEDGEMENT

Our thanks gift to Yanita Prihantari as a researcher, in which the results of her experiments we were use as the data base of this paper. At the time of the experiment, the researchers still a student in order to achieve a bachelor's degree in agricultural science.

REFERENCES

- Anonymous.?_. *Roselle (plant)* From Wikipedia, the free encyclopedia.[http://en.wikipedia.org/wiki/Roselle_\(plant\)](http://en.wikipedia.org/wiki/Roselle_(plant))
- Mardjuki, Asparno. 1990. *Pertanian Dan Masalahnya*. Pengantar Ilmu Pertanian. Edisi Pertama, Cetakan Pertama. Penerbit Andi Offset. Yogyakarta.
- Morton, J. 1987. *Roselle*. p. 281–286. In: Fruits of warm climates. Julia F. Morton, Miami, FL.<http://www.hort.purdue.edu/newcrop/morton/roselle.html>
- Prihantari, Yanita.2008. *Pengaruh Intensitas Sinar Matahari Dan Ukuran Polibag Terhadap Pertumbuhan Dan Hasil Tanaman Rosela*. Jurusan Agronomi. Fakultas Pertanian. Universitas Pembangunan Nasional “Veteran” Yogyakarta. (Unpublished).

GROWTH PERFORMANCE AND POTENTIAL OIL CONTENT OF SEVERAL BASIL (*Ocimum basilicum* Linn) VARIETIES AS FRUIT FLY CONTROLLER

S. Yuniastuti, L Rosmahani, E Korlina dan W. Handayati
East Java Assessment Institute for Agricultural Technology
JI Raya Karangploso, Km 4 Malang. Telp (0341) 494052
E-mail yuniastutisri@yahoo.com

ABSTRACT

Basil plant (*Ocimum basilicum* Linn) produce essential oil that can mimics female insect sex pheromone and attracts male insect especially fruit fly *Bactrorera dorsalis*, potentially can be fruit fly controller. Essential oil is highly sought because this natural attractant isn't readily available in the market. The plant grow and adapt to various environment easily. Balai Penelitian Tanaman Obat Dan Rempah Bogor (Balitro) has two superior varieties with high potential oil's yield. Assessment to assert growth performance and oil potential of some basil varieties had been done in Oro-Oro Ombo Wetan, Rembang, Pasuruan at 2009. The assessed varieties are green and purple basil from Balitro, which are compared with local variety from Pandaan. They were planted in area of 1.500 m². Data of growth were collected prior harvesting time, ie: plants height, canopies length, and number of branches. Harvesting was done at the age of 3 month and the gross weight of plant's yield, gross weight of plant's yield of vegetative and generative part per plant were observed. Three month after planting, local basil had highest growth with 78.2 cm height, 87.3 cm canopy length, and 183 branches, while green basil had lowest growth with 54.8 cm height, 76.7 cm canopy length, and 115 branches. Gross weight of yield on local basil was 636.1 g/plant, purple basil was 419.4 g/plant, and green basil was 213.3 g/plant (are these dry weight?). The average content of oil yield for purple basil was 0.62%, green basil is 0.55%, and local basil is 0.45%.

Keywords: Basil (*Ocimum basilicum* Linn.); Variety; Growth; Basil oil.

INTRODUCTION

Basil (*Ocimum basilicum* Linn.) is a straight growing herb plant species with 45- 90 cm height. Leaves and stem are colored green to purple according to variety and emitting a very sharp fragrance. Basil plant can produce oil with fragrance that resemble female insect sex pheromone that will attract male insect especially *Bactrocera dorsalis* fly fruit, so this plant has potential as fly fruit controller at horticulture crops. Basil extracts attractant use in fly fruit controlling is still new for farmers because information of fly fruit controlling with basil extract hasn't yet reach them and basil extract still unavailable yet in market.

Basil oil is an essential oil, which is a metabolism residue of plants. The oil was synthesized inside glandular cells in plant tissue and there is that also formed inside resin tubes (Ketaren, 1985). Basil extraction is easy to do by leaves and flowers distillation. Every 1 kg dried basil harvest can produce 6- 15 ml basil oil according to harvest drying condition (Sutjipto *et al.*, 2008). According to Pitojo (1996) basil oil content average is about 0.18- 0.23% and content size is affected by crop ages. Basil oil content, active substance content and percentage are very varied between species. Basil oil production is estimated to be able to compete with synthetic attractant which has Rp 1,100,000.00/ liter price.

Basil plant is easy to get and be cultivated because it is adaptable with various environments. There is many variety of basil with different growth performance and essential oil content. Bogor Medicinal and Spices Plant Research Institute (Balai Penelitian Tanaman Obat dan Rempah Bogor - Balitro) had 2 superior varieties of basil that had potential to produce higher basil oil content compared with other basil. To produce basil oil, it is necessary to introduce basils with higher essential oil contents. Besides that, to increase harvest, the usually grown wildy plants need to be cultivated so that it will gain more essential oil.

METHODOLOGY

Assessment were done in village Oro-Oro Ombo Wetan, subdistrict Rembang, district Pasuruan from May – December 2009 with field width 1500 m². Basil varieties planted were green and purple basil which came from Balitro which compared with local basil from Pandaan. Each variety was planted in 5 embankments. Cultivation technique was based on Balitro's recommendation. Basil seeds were taken care in seedbed with compost and soil mixed media (1:1) for 1 month with watering twice a day. Field was made into beds with 100 cm width, 20 cm height and length is appropriated with field's condition. Space between beds is 30 cm for drainage channel and easy maintenance. Planting gaps are 50 x 50 cm and planting holes by using hole maker are as deep as 10 cm. Watering is done once a week until plant ages one month and continued once every two weeks.

Fertilization recommendations to basil plant are 100 kg/ ha Urea and 150 kg/ ha Phonska, given 2 weeks after planting (Dhalimi *et al.*, 1999). 2 ton/ ha organic fertilizer (compost) was given during planting as basic fertilizer and applied at planting holes. Observation was done to 15 samples per bed including plants growth (plant height, canopy width, number of branches per plant) and stem color, leaves stalk, leaves, flower and flower shapes' performance which observed near harvest. At 3 months age plants harvested and being observed for harvest's wet weight per plant, vegetative and generative parts harvest' wet weight per plant.

Harvesting was done from 30 cm from plant base, sol that it can grow again for 2nd and 3rd time. Harvest was dried in open air for 2- 3 days, and then distilled for 3 hours to observe the content as well as produce basil oil. Basil oil distillation result was used to trap fly fruit on mango plant from flower forming until post harvest.

For traps, ex-1500 ml mineral water plastic bottle were used, in which given small holes in 4 places for fly fruit entrance into the bottle. In the middle of the bottle a wad of cotton sprinkled with 1.5 ml basil oil is hanged. In the bottom of bottle half teaspoon of

carbofuran were given to kill the fly fruits. Trapping bottles were set at 2 m height; in 1 ha 25 placing points were set with the gap between traps 10- 20 m. Basil oil application on cotton were repeated every 1.5 months.

RESULT AND DISCUSSION

Observation result of basil plants growth when near harvesting which is 3 months after planting, shows that local basil has highest plant growth, widest canopy and highest number of branches, while green basil from Balittro has the shortest plant growth, smallest canopy and lowest number of branches (Table 1). All three varieties were entering blossoming phase at the same time which is 30 days after plant and at 3 months the plants shows that leaves are turning yellow, fruits start to dry which means the plants are ready for harvest.

Table 1. Growth performance of 3 basil variety age 3 months after planting

Growth component	Purple basil from Balittro	Green basil from Balittro	Local basil from Pand
Plant height (cm)	58.6	54.8	78.2
Canopy width (cm)	77.5	76.7	87.3
Number of branches	143	115	183
Blossoming age (hst)	30	30	30
Stem color	Dark brown	Green	Dark brown
Leaf stalk color	Dark brown	Light green	Light Brown
Leaf color	Dark green	Light green	Dark green
Flower color	Dark purple	Green	Greenish purple
Flower shape	Cluster	Cluster	Single

According to observation on stem, leaf stalk, leaf, flower color and flower shape, then the purple basil from Balittro is *Ocimum sanctum* and green basil from Balittro is *Ocimum tenuiflorum* (Kardinan, 2004). While local basil from Pandaan is *Ocimum gratissimum* (Pitojo, 1996). Those three basil plant varieties performance can be shown at picture 1- 3.



Picture 1. Purple basil,
Ocimum sanctum



Picture 2. Green basil,
Ocimum tenuiflorum



Picture 3. Local basil
Ocimum gratissimum

According to harvest result at 3 months after planting, then harvest result wet weight per plant is highest at local basil from Pandaan and lowest at green basil from Balittro

(Table 2). This was supported by plant growth performance observation result in which local basil from Pandaan has bigger growth than other varieties. Likewise generative and vegetative parts harvest result wet weights are highest at local basil from Pandaan and lowest at green basil from Balitro.

Table 2. Harvest result performance and oil content of 3 basil varieties 3 months after planting.

Harvest result component	Purple basil from Balitro	Green basil from Balitro	Local basil from Pandaan
Harvest result wet weight per plant (g)	419.4	213.3	636.1
Harvest result generative parts wet weight (g)	132.4	83.7	199.1
Harvest result vegetative parts wet weight (g)	287.0	129.6	437.0
Distilled oil content (%)	0.62	0.55	0.45

(branches, leaves and flowers) distillation at age 3 months after planting shows that highest basil oil content average is on purple basil from Balitro which is 0.62% and the lowest is on local basil from Pandaan which is 0.45%, which is quite high. According to research result from Balitro, basil oil content from leaves distillation is about 0.18-0.56%, from flower is about 0.7%, and from branches is about 0.01% (Kardinan, 2003). Basil oil distillation process can be seen in Picture 4- 6.

Besides basil oil, distilled water also can be used for fly fruit traps (Picture 7), but the effectiveness hasn't observed. Green basil oil application can catch fly fruit twice more compared with available fly fruit traps on the market. Caught fly fruits average after trap installation on the 2nd days is 143, 4th days is 407, 7th days is 402, 9th days is 225 and 11th days is 204 (Rosmahani *et al.*, 2009). From Balitro research result (2004), fly fruit controlling that quite effective, eco friendly and doesn't leave residue on fruit is by using vegetable oil that has methyl eugenol (C₁₂H₂₄O₂) as its active ingredient and one of them is came from basil plant.



Picture 4. Basil harvest result were dried on open air for 2- 3 days



Picture 5. Basil distillation process



Picture 6. Distillation result which are water and oil



Picture 7. Fly fruit trap with basil oil and basil distilled water

CONCLUSION

Observation result at age 3 months after planting shows that:

1. Local basil growth performance has 78.2 cm plant height, 87.3 cm canopy width and 183 branches, purple basil growth performance had 58.6 cm plant height, 77.5 cm canopy width and 143 branches, green basil growth performance had 54.8 cm plant height, 76.7 cm canopy width and 115 branches.
2. Harvest result wet weight of local basil is 636.1 g/ plant, purple basil is 419.4 g/ plant, and green basil is 213.3 g/ plant.
3. Basil oil content average of purple basil is 0.62%, green basil is 0.55%, and local basil is 0.45%.

REFERENCES

- Anonim. 2004. Perangkap lalat buah. Leaflet. Balai Penelitian Tanaman Rempah dan Obat.
- Dhalimi, A., Iskandar, M., and Ma'mun. 1999. Pengaruh cara pemberian pupuk terhadap pertumbuhan, produksi daun, rendemen minyak dan kandungan methyl eugenol tanaman selasih. Prosiding Forum Komunikasi Ilmiah Pemanfaatan Pestisida Nabati. Bogor, 9 – 10 Nopember 1999: 514 – 519.
- Kardiman, A., 2003. Mengenal lebih dekat Selasih, tanaman keramat multimanfaat. PT Agromedia Pustaka.
- _____, 2004. Pestisida nabati, ramuan dan aplikasi. Penebar swadaya, Bogor.
- Ketaren, S., 1985. Pengantar Teknologi Minyak Atsiri. Balai Pustaka. Jakarta.
- Pitojo, S., 1996. Kemangi dan selasih. PT Trubus Agriwidya.
- Rosmahani, L., Yuniastuti, S., Handayati, W., Korlina, E., Budiono, Al., Daldiri, M., Amalia, L., and Nu'arofah. 2009. Pengembangan atraktan berbasis ekstrak selasih untuk pengendalian lalat buah mangga di Jawa Timur. Laporan Hasil Pengkajian. BPTP Jawa Timur.
- Sutjipto, Sigit, P., and J., Wildan. 2008. Pengendali lalat buah *Bactrocera dorsalis* Hend pada tanaman cabai merah dengan ekstrak daun selasih (*Ocimum sanctum* L.). Naskah bahan Rakitek BPTP Jawa Timur.

SURVIVAL OF SUGARCANE WHITE GRUB IN TREATED SOIL BY ENTOMOPATHOGENIC FUNGI

Harjaka T¹, B.H. Sunarminto² and E. Martono¹

¹Departement of Pests and Plant Diseases, Faculty of Agriculture, Universitas Gadjah Mada (UGM), Indonesia. Telph. (Fax): (0274) 523 926,

² Departement of Soil Science, Faculty of Agriculture, Universitas Gadjah Mada (UGM), Indonesia.
Email: triharjaka@yahoo.co.id

ABSTRACT

White grub, *Lepidiota stigma* is one of destructive pest of sugarcane in Indonesia. The fungi *Metarhizium anisopliae* is known as pathogen of this pest. The aims of this research is to determine the survive ability of *L. stigma* larvae on treated soil with *M. anisopliae*. This fungi was reproduced in the laboratory using sterile corn media for 30 days, which it harvested and treated in sandy loam soil with concentration range 10^5 - 10^8 spores/gram. Each concentration was tested on 10 second instar larvae of the of *L. stigma* with three replications. During it, the larvae reared and feed by fresh carrots and food replacement done each time on the same week of observation. The results showed that *M. anisopliae* has ability to inhibit the development of the instar larvae of *L. stigma* when it turn to third instar, pupa and adulthood. Highest inhibition occurs when third instar larvae phase did not eat, and it ranged between 46-100%, whereas when entering the third instar stadia the inhibition ranged between 16-56%. Treatment with *M. anisopliae* concentrations of 10^8 spores/gram on soil gave the highest inhibition and reached 100% in third instar larvae of *L. stigma*, while the treatment of 10^5 , 10^6 and 10^7 spores/gram still managed to hold its development of larvae reaching prepupa. Treatment of the fungi at a concentration of 10^5 and 10^6 spores/gram is capable causing mortality of *L. stigma* larvae reached 93.33% and 96.67%, while the treatment of 10^7 - 10^8 spores/gram already caused 100% larvae failed to reach adult life.

Keywords: *Lepidiota stigma*, survival, insect pathogens, soil treatment

INTRODUCTION

Lepidiota stigma F. (Coleoptera : Scarabaeidae) mentioned as a destructive pest of sugarcane in Indonesia. The incidence of this beetle usually occur severy year on the beginning of the rainy season around October-November (Kalshoven, 1981). General pest management still facing this problems because it difficult to find the right strategy which appropriate with the period of it incidence. Chemical control using chemical pesticides disposed to be less effective when the attack symptom sappeared because most white grub already entered the third instar larvae and pre pupae. In the water sufficient area, crop

rotation between sugarcane and rice is one solution that many farmers do for reducing its population (Suhartawan, 1995), but it was not easy to do in the rain-fed land with sandy soil type because the pest prefers soil with content of 40-60% sand (Mahrub *et al.* 1975, Cherry and Alsopp, 1991)

Using of insect pathogenic fungi, *Metarhizium anisopliae* Metchnikoff is an attempt to control the white grub destroyer of caneroots in the long run. Utilization of fungi *M. anisopliae* as a biological control agent of white grub has evolved since its discovery on 1879 by Metchnikoff infect the beetles *Anisoplia austriaca* Hbst in Russia (Bucias and Penland, 1998). In Japan, fungi *M. anisopliae* is used to control the white grub *Anomala cuprea* destroyer of sweet potato roots (Fujiie and Yokoyama, 1996) and in Australia to control pests of sugarcane white grub (*Dermolepida albohirtum*), has even made solid formulations (granules) under the trade name BioGreen^R and BIO-Cane^R to be applied to control of white grub (Milner, 2000; Milner, *et al.* 2003; Sallam *et al.*, 2007, Allsopp, 2011). Fungi *M. anisopliae* is one of the biological control agent, which has also been used in some countries such as Australia (Sallam, 2011) and India (Manisegaran *et al.*, 2011), has even formulated and evaluated its success (Allsopp, 2010).

Fungi *M. anisopliae* has been reported to be have as a saprophyte in the soil, so that the application can be persistent in soil was reported at a depth of 10-30 cm, thus potentially infect of white grub (Sallam, *et al.*, 2007; Bruck, 2010). In 2003 isolates of *M. anisopliae* potentially infect *L. stigma* has been found and has been tested in the laboratory can of *L. stigma* (Harjaka, 2010).

M. anisopliae is a soil fungi that life in soil, infected insects and it can live in the soil. Most of the time *L. stigma* survive in soil and hatching eggs to develop into pupae also need the appropriate humidity. The fungi has many advantages such as saprophyte is able to evolve and form resistant structures (Jackson and Jaronski, 2009) in plant roots so as protector of destructive pests attack the roots (Bruck, 2010). Under these conditions, the use of *M. anisopliae* as biological control agents of white grub destroyer sugarcane roots need to be developed in Indonesia. Compliance of fungal ecology studies on *M. anisopliae* and white grub needs to be done to strengthen the basic considerations in engineering applications.

MATERIAL AND METHODS

The larvae of *L. stigma* as test material obtained from maintenance in Biological Control Laboratory, Faculty of Agriculture, Universitas Gadjah Mada, Yogyakarta, Indonesia since November 2011 until May 2012. There is 900 larvae of *L. stigma* separated by stadia (instars) and placed on a volume of 500ml plastic pots with Regosol soil type as media and humidified to 10-15% moisture content. The larvae feed by fresh carrots 5 g/larva and added/replaced every 5-7 days. To maintain soil moisture maintenance medium was added water. Development of *L. stigma* each instar larvae is recorded to determine the age.

Fungi *M. anisopliae* isolates obtained from Biological Control Laboratory Faculty of Agriculture, Universitas Gadjah Mada. Fungal isolates were grown on potato dextrose agar medium (PDA) in 9 cm diameter petridish. For test purposes infection in laboratory and applications in the field, the fungi reproduce during the natural medium of maize are

cooked and sterilized. Fungal cultures were incubated at 30°C for 30 days, then performed calculations to determine the viability of spores and the number of infective propagules least 10^{10} spores/g culture.

For laboratory testing, fungi have been culture in medium corn until the age of 30 days and then harvested and mixed with the soil concentration series 10^5 - 10^8 spores/g soil. Then incubated soil at least 2 weeks before that fungi growing in the soil. Soil that had been inoculated by fungi *M. anisopliae* prepared for larval rearing media. Sensitivity of larval stadia of *L. stigma* against infections of the fungal is suspected there is a difference. Therefore in testing conducted on the second instar larvae. At each spore concentration series of *M. anisopliae* prepared 10 larvae with three replications. Observations were made every seven days until larvae change to be beetle (210 days).

RESULTS AND DISCUSSION

The results showed that the fungi *M. anisopliae* were treated to live on the soil and able to infect larvae of *L. stigma*. The second instar larvae of *L. stigma* reared on contaminated soil fungi under go a developmental disorder with varied symptoms. Most larvae become infected when preparing molting and partially replace the infected several days after molting. Based on these events indicate that the fungi can infect *L. stigma* when it being in active, so the possibility of contact with fungal propagules greater. When the larvae are active again become the third instar be less susceptible to fungal infection. The incidence of infection still occurs when the insects are not active again before the pre-pupae. Results of research that has been conducted since May 2012 until August 2012 that some larvae of *L. stigma* that has entered the third instar was able to survive until the stadia are not eating, but most have failed to reach pre-pupal stadia.

Based on observations of mortality due to fungal infection *M. anisopliae* showed that survival of *L. stigma* larvae impaired that can not carry out the process of molting to be pupa and adult. The number of larvae that successfully reach adulthood lower than controls. At concentration the fungi 10^5 spores/g soil treat all larvae showed that all *L. stigma* larvae to establish a change of cuticle but failed to reach a pre-pupae reaches more than 45% and only 10% were able to become pupae. While the treatment was 10^7 spores/g soil caused molting failure to reach 13.33% and more than 96% fail in pupae. Treatment of 10^8 spores/g soil caused mortality reaches 100% in pre-pupae that failed to be no adults emerged (Fig 1.).

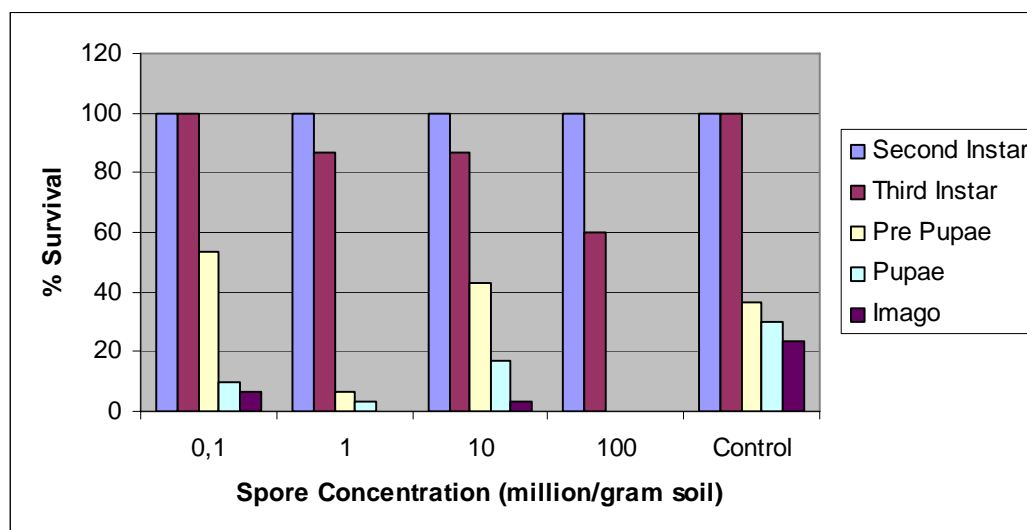

Fig 1. Survival of *Lepidiota stigma* in soil treated with the fungi *Metarhizium anisopliae*

Based on the observations the incidence of infection and mortality of larvae indicates that the potential of fungi *M. anisopliae* for control insects in the soil. The fungi needs time to develop in the soil before infecting *L. stigma*, and the critical phase of infection is when insects carry out the molting. The higher concentration of fungal spores *M. anisopliae* in the soil tends to accelerate the occurrence of infections and increase mortality.

CONCLUSSION

Fungi *M. anisopliae*-treated in the soil can be sustained and capable to disturb the survival of *L. stigma*. The treatment of the fungi *M. anisopliae* with higher concentrations can accelerate of infection against *L. stigma* and increased mortality

REFERENCES

- Allsopp, P. 2010. Integrated Management of Sugarcane White Grubs in Australia : An Evolving Success. *Annu. Re. Entomol.* (55) : 329-349
- Bruck, D.J. 2010. Fungal Entomophthogens in the Rhizosphere. *BioControl* (55) : 103-112
- Bucias, D.G. and J.C. Pendland. 1998. *Principles of Insect Pathology*. Kluwer Academic Publishers. London.
- Fujie, A. and A. Yokoyama. 1996. Improvement and Use of *Metarhizium anisopliae* for Controlling *Anomala cuprea*. *Proceeding of the International Symposium on The Use of Biological Control Agents under Integrated Pest Management*. Pp : 61-69

- Harjaka, T. 2010. Susceptibility of *Lepidiota stigma* (Coleoptera : Scarabaeidae) to *Metarhizium anisopliae* (Hypocreales : Clavicipitacea). Proceeding of International Conference on Food Safety and Food Security, December, 1-2, 2010. Pp : 208-212.
- Harjaka, T., Wibowo, A. and Wasis, M. 2011. Patogensity of *Metarhizium anisopliae* against Larvae of *Lepidiota stigma*. Papper presented on the Seminar on Botanical Pesticide, Jakarta. Indonesia. Oct, 15, 2011.
- Jackson, M.A. & Jaronski, S.T. 2009. Production of Microsclerotia of the Fungal Entomopathogen *Metarhizium anisopliae* and their Potential for Use as A Biocontrol Agent for Soil-Inhabiting Insects. *Mycology Research* (113) : 842-850.
- Kalshoven, L.G.E. 1981. *The Pests of Crops in Indonesia*. PT. Ichtiar Baru Van Hoeve, Jakarta.
- Mahrub, E., Rasdiman, S. and M. Prawirodisastro. 1975. Biology *Lepidiota stigma* in Laboartory. Faculty of Agriculture, UGM.
- Manisegaran, S., Lakshmi, M. and Srimohanapriya, V. 2011. Field Evaluation of *Metarhizium anisopliae* against *Hollotrichia serarata* in Sugarcane. *Jurnal of Biopesticides* (4) : 190-193.
- Milner, R.J. 2000. Current Status of *Metarhizium* as A Mycoinsecticide in Australia. *BioControl News Information* (21) : 47-50.
- Milner, R.J., Samson, P. and R. Morton. 2003. Persistence of Conidia of *Metarhizium aaanisopliae* in Sugarcane Fields: Effect of isolate and formulation on persistence over 3.5 years. *Biocontrol Science and Technology*, (13) : 507-516
- Sallam, M.N., McAvoy, C.A., Samson, P.R. and J.J. Bull. 2007. Soil Sampling for *Metarhizium anisopliae* Spores in Queensland Sugarcane Fields. *BioControl* (52) : 491-505.
- Samson, P.R., Stair, T.N. and J.I. Bull. 2006. Evaluation of an Application Procedure for *Metarhizium anisopliae* in Sugar Cane Ratoons for Control of the White Grub *Dermolepida albohirtum*. *Crop Protection* (25) : 741-747.
- Sallam, N. 2011. Review of Current Knowledge on the Population Dynamic of *Dermolepida albohirtum* (Waterhouse)(Coleoptera : Scarabaeidae). *Australian Journal of Entomology* (50) : 300-308
- Suhartawan, 1995. Mechanical Control of *Lepidiota stigma* F. In Sugarcane Plantation in Indonesia. *Majalah Penelitian Gula (Indonesia)* (31) : 45-53

APPLICATION OF NANOPARTICLES IN PEST MANAGEMENT PROGRAMMS- A REVIEW

Masumeh Ziaee^{1*}, and Fatemeh Hamzavi²

¹ Department of Plant Protection, Faculty of Agriculture, ShahidChamran University of Ahvaz, Ahvaz-Iran. P. O. Box: 61357-43311.

² Department of Entomology, Faculty of Agriculture, TarbiatModares University, Tehran, Iran.

email: masumeh_ziaee@yahoo.com

ABSTRACT

Protection of agricultural products from pest's infestations is in the concern of government, farmers, and those involved in this matter. Since earlier times, synthetic pesticides are being used for pest control. However, pesticides degradation and its low stability in the environment, hazardous effects to human and environmental contamination have increased the tendency to the use of alternatives of synthetic pesticides. Micro and nanomaterial-based pesticides are one of the formulations that have been considered as a suitable alternative to pesticides. Encapsulation effectively protect pesticides from adverse effects of environment such as temperature, rain, UV light, etc and enhanced solubility and dissolution rate of poorly water-soluble pesticides and released the active ingredient of the pesticides in a controlled and efficient manner. Microcapsules-based formulations are known for some decades. The first microcapsule-based formulation became commercial in the 1974. However, few researches have been conducted on the field of production and application of nano-based formulated pesticides for pest management. Nanoparticles have a greater surface area to volume ratio, which increases their activity level and diffusion. This review focuses on the Nano-formulated pesticides as they are applied in pest management programs.

Keywords: crop protection, encapsulation, patent, pesticide, nanoparticles

INTRODUCTION

Pesticides encapsulation is performed in order to control release of active ingredient; as well as protection of pesticides from environmental adverse effects, increased their chemical stability, persistence and decreased their toxicity to non-target species, mammals and beneficial insects. Different chemical and physical techniques have been developed to prepare nanoparticles loaded with pesticides. Several encapsulated pesticides have been prepared with slow-release properties. The control release system of pesticides was first introduced by Allan *et al.* (1971). Here is an overview of some papers and patents on the use of nanoparticles for pest management.

A. Nanoparticles for pest management

Some of the metal, nonmetal and metal oxide nanoparticles have insecticidal efficacy. Nanostructured alumina was developed as an insecticide and its toxicity was shown against some stored product pests (Stadler *et al.*, 2010; Stadler *et al.*, 2012). Nanosilver (Ag), nano-cadmium sulfide (CDS) and nanotitanium dioxide (TiO₂) were proved to be effective against *Spodoptera litura* (F.) and hence can be selectively used for suppression of the pest. Nanoparticles efficiently penetrate into microbial cells and malformed larvae of the insect (Fig. 1) (Chakravarthy *et al.*, 2012). Silver nanoparticles were also approved to have antifungal activity and could control powdery mildews on cucumber and pumpkin (Lamsal *et al.*, 2011b), *colletotrichum* species and pepper anthracnose disease in the field. Nanoparticles inhibited growth of fungal hyphae and conidial germination (Lamsal *et al.*, 2011a). The larvae of *Aedes albopictus* mosquito was effectively controlled using silver nanoparticles synthesized from the aqueous leaf extract of *Hibiscus rosasinensis* (Sareen *et al.*, 2012). Nano-sulfur was found to inhibit sporulation and growth of fungi (Goswami *et al.*, 2010). Sulfur nanoparticles inhibited phytopathogens such as *Fusarium solani* responsible for early blight and Fusarium wilt diseases and *Venturia inaequalis* responsible for the apple scab disease (Rao & Paria, 2013). Amorphous lipophilic silica nanoparticles were proved to have toxicity on *Tribolium castaneum*, a stored grain insect pest (Debnath *et al.*, 2012). Nanosilica was indicated insecticidal toxicity against some mosquito species that transmit human diseases (Barik *et al.*, 2012; Goswami *et al.*, 2010).



Fig 1: Malformed larvae of *S. litura* treated with CdS (2), Nano-Ag (3), Nano-TiO₂ (4) and control (1) (Chakravarthy *et al.*, 2012).

B. Pesticide-loaded nanoparticles

Some of the nanoparticles have been developed that have the potency of loading different kinds of pesticides such as insecticides, insect pathogens, nematicides, herbicides, fungicides and etc.

Crooks *et al.* (2003) patented the use of an aqueous suspension of nanoparticles comprising an organic active ingredient such as pesticides. In this invention controlled release of active ingredient occurs. Slow release of pesticides has advantages such as cost effective, environment safety by preventing pesticide overuse and soil leaching into

waterways, reducing risk of plants phototoxicity and toxicity to humans. Insecticides, nematicides, herbicides, fungicides, aphicides, miticides, and etc. are formulated with this technique.

A solid crop protection formulation was invented comprising at least one crop protection agent as herbicides, pesticides and fungicides. Nanodispersions is a stable nanoparticulate form in aqueous medium and novel copolymers which are suitable to stabilize nanoparticles of said crop protection agent in redispersed aqueous dispersion formulations. Stable particles are defined as particles that do not crystallize, aggregate, flocculate or precipitate out of the aqueous medium for a period of time depending on the application (Matthias Bratz *et al.*, 2003).

Magdassi *et al.* (2010) developed redispersible powder and aqueous dispersion of nanoparticles for water insoluble organic pesticides. Nanoparticles were prepared of an oil-in-water nanoemulsion and solvent removal technique, having a droplet size of about 300 nm or less. This invention applied for water insoluble pesticides such as lambda-cyhalothrin and novaluron (Rimon®) which combat pests by application to the crops.

Ishaque *et al.* (2011) invented a pesticide coated metal oxide nanoparticles and comprising a UV photoprotective filter. This formulation is recommended for controlling harmful insects, phytopathogenic fungi and undesired herbs. Pyrethroid insecticides would be encapsulated with this technique.

C. Insecticide-loaded nanoparticles

In most cases nanoparticles are produced as a carrier of pesticides and their insecticidal efficacy is not considered. Porous hollow silica nanoparticles (PHSN) were prepared via a sol-gel route using inorganic calcium carbonate nanoparticles. PHSN was applied as a pesticide carrier and first loaded with avermectin. The authors reported that release profile of avermectin depended on shell thickness, place of loading (external surface, the wall or the inner core of the PHSN carriers) and other factors such as pH and temperature. However, PHSN effectively controlled release of avermectin (Li *et al.*, 2006; Wen *et al.*, 2005). The oil-in-water nanoemulsion (O/W) was produced to formulate water-insoluble insecticides such as β -cypermethrin (β -CP) (Wang *et al.*, 2007). The formulation decreased the concentration required for effective control in commercial spray applications, without losing efficiency and enhanced stability of pesticides. Imidacloprid is also one of the insecticides encapsulated with chitosan and sodium alginate through layer-by-layer self-assembly (Guan *et al.*, 2008). Residue of the novel imidacloprid was detected below the limit in the soybean plant and much lower than the USA Environmental Protection Agency's Maximum Residue Level (Guan *et al.*, 2010). Soresh *et al.* (2011) developed nanosilver conjugated to the pyrethroid pesticide, deltamethrin which was effective against arthropod vectors, such as mosquitoes. Pyriproxyfen nanoparticles with effective controlled-release feature were developed by Kang *et al.* (2012) and its effectiveness was found against *Myzus persicae*. Fabrics were patented and loaded with pyrethroid nanocapsules to increase the durability of insecticide even after successive washing and solar exposure (Xin & Bin, 2007). Recently, natural based insecticides are considered as biopesticides. Yang *et al.* (2009) produced polyethylene glycol coated nanoparticles with melt-dispersion method and loaded with garlic essential oil. They stated that oil-loaded nanoparticles were more effective than the essential oil against stored product insect pests and the encapsulation

process increased the durability of the essential oil even more than 5 months. Ziaee (2013) developed cumin and ajwain essential oil-loaded nanogels and declared persistence and insecticidal efficacy of oil-loaded nanogels against some stored product insect pests was about 3-6 fold more than the oils

D. Entomopathogen-loaded nanoparticles

Different patents focus on the encapsulation of biological control agents in order to protect them from rapid environmental degradation caused by exposure to ultraviolet radiation, substrate pH, heat, desiccation and microbial competition which limits their practical application. The idea of using encapsulated biological control agents such as pathogenic bacteria and viruses was patented in 1989. In this invention, biological control agents have been encapsulated in a protective starch matrix. Encapsulated products are recommended for controlling pests having chewing mouthparts and amylase digestive enzymes (Shasha & Dunkle, 1989; Shasha & Mcguire, 1998). There are a lot of reports on the microencapsulation of entomopathogens specially *Bacillus thuringiensis* (Côté *et al.*, 2001; Dunkle & Shasha, 1989; Hernández-Rodríguez *et al.*, 2013; Margalit *et al.*, 1984; Yang *et al.*, 2012) *Beauveria bassiana* (Liu & Liu, 2009; Mishra *et al.*, 2013) and *Metarhizium anisopliae* (Pereira & Roberts, 1991). However, preparation of nanocapsules loaded with entomopathogens has not been considered.

E. Fungicide-loaded nanoparticles

Nanoparticles as carrier systems for fungicides could develop sustained release systems of these chemicals and increase their performance and efficiency (Fraceto, 2013). Nanoparticles were loaded with tebuconazole or chlorothalonil fungicides as aqueous dispersions to treat sapwood of southern yellow pine and birch. Nanoparticles were prepared using polyvinylpyridine (PVPy) and polyvinylpyridine-co-styrene (Liu *et al.*, 2003). Amphotericin B nanodisks enhanced amphotericin antibiotic solubility and protect against environmental damage. The formulation was reported to be effective against several phytopathogenic fungi (Pérez-de-Luque *et al.*, 2012).

F. Nematicide-loaded nanoparticles

Nanocapsules of lansiumamide B were prepared by the microemulsion polymerization method and its nematicidal efficacy was proved (Yin *et al.*, 2012).

G. Herbicide-loaded nanoparticles

There are a lot of reports on the encapsulation of herbicides. Herbicide-loaded nanoparticles would reduce the risks of phytotoxicity on the crops, causes better penetration of herbicides through cuticles and tissues, allowing slow and constant release of the active substances (Pérez-de-Luque & Rubiales, 2009). Silva *et al.* (2010) prepared alginate nanoparticles as a delivery system for the clomazone herbicide. They declared that nanoparticles have biodegradable release system using herbicide for later release into more specific targets, avoiding contamination of environmental matrices. Silva *et al.* (2011) developed Paraquat-loaded alginate/chitosan nanoparticles and

proved that nanoparticles changed the release profile of the herbicide and its interaction with the soil. Therefore, application of herbicide loaded nanoparticles could be an effective means for reducing negative impacts caused by herbicides. Manganese carbonate (MnCO₃) core-shell nanoparticles were synthesised using wet chemical methods for loading herbicide pendimethalin (Kanimozhi & Chinnamuthu, 2012). Water-soluble herbicide, glyphosate isopropylamine, was prepared using a green nanoemulsion system, and its biological activity was reported against the weeds creeping foxglove, slender button weed and buffalo grass (Lim *et al.*, 2013). Zero-valent iron nanoparticles loaded with chloroacetanilide herbicide (alachlor) reduced the degradation of the herbicide (Thompson *et al.*, 2010).

CONCLUSION

The main goal of pesticide encapsulation is: protecting pesticides and increasing their stability during storage or after application to the environment, increasing effectiveness of pests control with controlled and impressive release of the pesticides, reducing adverse effects of pesticides to the environment and humans. Therefore, formulating pesticides in nanoparticles should be considered for agricultural health and safety.

REFERENCES

- Allan, GG, Chopra, CS, Neogi, AN, & Wilkins, RM 1971, 'Design and Synthesis of Controlled Release Pesticide-Polymer Combinations', *Nature*, vol. 234, no. 5328, pp. 349-351.
- Barik, T, Kamaraju, R, & Gowswami, A 2012, 'Silica nanoparticle: a potential new insecticide for mosquito vector control', *Parasitology Research*, vol. 111, no. 3, pp. 1075-1083.
- Chakravarthy, A, Kandakoor, S, Bhattacharya, A, Dhanabala, K, Gurunatha, K, & Ramesh, P 2012, 'Bio efficacy of inorganic nanoparticles CdS, Nano-Ag and Nano-TiO₂ against *Spodoptera litura* (Fabricius) (Lepidoptera: Noctuidae)', *Current Biotica*, vol. 6, no. 3, pp. 271-281.
- Côté, J-C, Vincent, C, Son, K-H, & Bok, SH 2001, 'Persistence of insecticidal activity of novel bio-encapsulated formulations of *Bacillus thuringiensis* var. kurstaki against *Choristoneura rosaceana* [Lepidoptera: Tortricidae]', *Phytoprotection*, vol. 82, no. 2, pp. 73-82.
- Crooks, R, Joanicot, M, Prud'Homme, RK, & Coret, J 2003, 'Aqueous suspension of nanoparticles comprising an agrochemical active ingredient', US 6,638,994 B2.
- Debnath, N, Das, S, Patra, P, Mitra, S, & Goswami, A 2012, 'Toxicological evaluation of entomotoxic silica nanoparticle', *Toxicological & Environmental Chemistry*, vol. 94, no. 5, pp. 944-951.
- Dunkle, R, & Shasha, B 1989, 'Response of starch-encapsulated *Bacillus thuringiensis* containing ultraviolet screens to sunlight', *Environmental Entomology*, vol. 18, no. 6, pp. 1035-1041.

- Fraceto, LF. (2013). 'Development of nanoparticles as carrier systems for fungicides Carbendazin and Tebuconazole aiming agriculture applications'. Universidade Estadual Paulista (UNESP). Campus Experimental de Sorocaba. Sorocaba, SP, Brazil.
- Goswami, A, Roy, I, Sengupta, S, & Debnath, N 2010, 'Novel applications of solid and liquid formulations of nanoparticles against insect pests and pathogens', *Thin Solid Films*, vol. 519, no. 3, pp. 1252-1257.
- Guan, H, Chi, D, Yu, J, & Li, H 2010, 'Dynamics of residues from a novel nano-imidacloprid formulation in soyabean fields', *Crop Protection*, vol. 29, no. 9, pp. 942-946.
- Guan, H, Chi, D, Yu, J, & Li, X 2008, 'A novel photodegradable insecticide: Preparation, characterization and properties evaluation of nano-Imidacloprid', *Pesticide Biochemistry and Physiology*, vol. 92, no. 2, pp. 83-91.
- Hernández-Rodríguez, CS, Ruiz de Escudero, I, Asensio, AC, Ferré, J, & Caballero, P 2013, 'Encapsulation of the *Bacillus thuringiensis* secreted toxins Vip3Aa and CryIIa in *Pseudomonas fluorescens*', *Biological Control*, vol. 66, no. 3, pp. 159-165.
- Ishaque, M, Schnabel, G, & Anspaugh, DD 2011, 'Agrochemical formulations comprising a pesticide, an organic UV-photoprotective filter and coated metal-oxide nanoparticles', US 2011/0111957 A1.
- Kang, MA, Seo, MJ, Hwang, IC, Jang, C, Park, HJ, Yu, YM, & Youn, YN 2012, 'Insecticidal activity and feeding behavior of the green peach aphid, *Myzus persicae*, after treatment with nano types of pyriproxyfen', *Journal of Asia-Pacific Entomology*, vol. 15, no. 4, pp. 533-541.
- Kanimozhi, V, & Chinnamuthu, C 2012, 'Engineering core/hollow shell nanomaterials to load herbicide active ingredient for controlled release', *Research Journal of Nanoscience and Nanotechnology*, vol. 2, no. 2, pp. 58-69.
- Lamsal, K, Kim, SW, Jung, JH, Kim, YS, Kim, KS, & Lee, YS 2011a, 'Application of silver nanoparticles for the control of colletotrichum species in vitro and pepper anthracnose disease in field', *Mycobiology*, vol. 39, no. 3, pp. 194-199.
- Lamsal, K, Kim, SW, Jung, JH, Kim, YS, Kim, KS, & Lee, YS 2011b, 'Inhibition Effects of Silver Nanoparticles against Powdery Mildews on Cucumber and Pumpkin', *Mycobiology*, vol. 39, no. 1, pp. 26-32.
- Li, Z-Z, Xu, S-A, Wen, L-X, Liu, F, Liu, A-Q, Wang, Q, Sun, H-Y, Yu, W, & Chen, J-F 2006, 'Controlled release of avermectin from porous hollow silica nanoparticles: Influence of shell thickness on loading efficiency, UV-shielding property and release', *Journal of Controlled Release*, vol. 111, no. 1-2, pp. 81-88.
- Lim, CJ, Basri, M, Omar, D, Abdul Rahman, MB, Salleh, AB, & Raja Abdul Rahman, RNZ 2013, 'Green nanoemulsion-laden glyphosate isopropylamine formulation in suppressing creeping foxglove (*A. gangetica*), slender button weed (*D. ocimifolia*) and buffalo grass (*P. conjugatum*)', *Pest Management Science*, vol. 69, no. 1, pp. 104-111.

- Liu, C-P, & Liu, S-D 2009, 'Low-temperature spray drying for the microencapsulation of the fungus *Beauveria bassiana*', *Drying Technology*, vol. 27, no. 6, pp. 747-753.
- Liu, Y, Laks, P, & Heiden, P 2003, 'Nanoparticles for the controlled release of fungicides in wood: soil jar studies using *G. Trabeum* and *T. Versicolor* wood decay fungi', *Holzforschung*, vol. 57, no. 2, pp. 135-139.
- Magdassi, S, Dayan, B, & Levi-Ruso, G 2010, 'Pesticide nanoparticles obtained from microemulsions and nanoemulsions', WO Patent WO/2008/032,328.
- Margalit, J, Markus, A, & Pelah, Z 1984, 'Effect of encapsulation on the persistence of *Bacillus thuringiensis* var. israelensis, serotype H-14', *Applied Microbiology and Biotechnology*, vol. 19, no. 6, pp. 382-383.
- Matthias Bratz, Robert Heger, Wolfgang Schrof, & Zagar, C 2003, 'Nanoparticles comprising a crop protection agent', WO2003039249 A2.
- Mishra, S, Kumar, P, & Malik, A 2013, 'Preparation, characterization, and insecticidal activity evaluation of three different formulations of *Beauveria bassiana* against *Musca domestica*', *Parasitology Research*, vol., no., pp. 1-11.
- Pereira, RM, & Roberts, DW 1991, 'Alginate and cornstarch mycelial formulations of entomopathogenic fungi, *Beauveria bassiana* and *Metarhizium anisopliae*', *Journal of Economic Entomology*, vol. 84, no. 6, pp. 1657-1661.
- Pérez-de-Luque, A, Cifuentes, Z, Beckstead, JA, Sillero, JC, Ávila, C, Rubio, J, & Ryan, RO 2012, 'Effect of amphotericin B nanodisks on plant fungal diseases', *Pest Management Science*, vol. 68, no. 1, pp. 67-74.
- Pérez-de-Luque, A, & Rubiales, D 2009, 'Nanotechnology for parasitic plant control', *Pest Management Science*, vol. 65, no. 5, pp. 540-545.
- Rao, KJ, & Paria, S 2013, 'Use of sulfur nanoparticles as a green pesticide on *Fusarium solani* and *Venturia inaequalis* phytopathogens', *RSC Advances*, vol. 3, no. 26, pp. 10471-10478.
- Sareen, SJ, Pillai, RK, Chandramohanakumar, N, & Balagopalan, M 2012, 'Larvicidal potential of biologically synthesised silver nanoparticles against *Aedes Albopictus*', *Research Journal of Recent Sciences*, vol. 1, no., pp. 52-56.
- Shasha, BS, & Dunkle, RL 1989, 'Starch encapsulation of entomopathogens', US 4,859,377.
- Shasha, BS, & Mcguire, MR 1998, 'Methods and compositions of adherent starch granules for encapsulating pest control agents', EP 5,837,273.
- Silva Mdos, S, Cocenza, DS, Grillo, R, de Melo, NF, Tonello, PS, de Oliveira, LC, Cassimiro, DL, Rosa, AH, & Fraceto, LF 2011, 'Paraquat-loaded alginate/chitosan nanoparticles: preparation, characterization and soil sorption studies', *Journal of Hazardous Materials*, vol. 190, no. 1-3, pp. 366-374.
- Silva, MdS, Cocenza, DS, Melo, NFSd, Grillo, R, Rosa, AH, & Fraceto, LF 2010, 'Alginate nanoparticles as a controlled release system for clomazone herbicide', *Química Nova*, vol. 33, no. 9, pp. 1868-1873.

- Sooresh, A, Kwon, H, Taylor, R, Pietrantonio, P, Pine, M, & Sayes, CM 2011, 'Surface functionalization of silver nanoparticles: novel applications for insect vector control', *ACS Appl Mater Interfaces*, vol. 3, no. 10, pp. 3779-3787.
- Stadler, T, Buteler, M, & Weaver, DK 2010, 'Novel use of nanostructured alumina as an insecticide', *Pest Management Science*, vol. 66, no. 6, pp. 577-579.
- Stadler, T, Buteler, M, Weaver, DK, & Sofie, S 2012, 'Comparative toxicity of nanostructured alumina and a commercial inert dust for *Sitophilus oryzae* (L.) and *Rhyzopertha dominica* (F.) at varying ambient humidity levels', *Journal of Stored Products Research*, vol. 48, no. 0, pp. 81-90.
- Thompson, JM, Chisholm, BJ, & Bezbaruah, AN 2010, 'Reductive dechlorination of chloroacetanilide herbicide (alachlor) using zero-valent iron nanoparticles', *Environmental Engineering Science*, vol. 27, no. 3, pp. 227-232.
- Wang, L, Li, X, Zhang, G, Dong, J, & Eastoe, J 2007, 'Oil-in-water nanoemulsions for pesticide formulations', *Journal of Colloid and Interface Science*, vol. 314, no. 1, pp. 230-235.
- Wen, L-X, Li, Z-Z, Zou, H-K, Liu, A-Q, & Chen, J-F 2005, 'Controlled release of avermectin from porous hollow silica nanoparticles', *Pest Management Science*, vol. 61, no. 6, pp. 583-590.
- Xin, JH, & Bin, F 2007, 'Insect repellent fabrics having nanocapsules with insecticide'.
- Yang, FL, Li, XG, Zhu, F, & Lei, CL 2009, 'Structural characterization of nanoparticles loaded with garlic essential oil and their insecticidal activity against *Tribolium castaneum* (Herbst) (Coleoptera: Tenebrionidae)', *Journal of Agricultural and Food Chemistry*, vol. 57, no. 21, pp. 10156-10162.
- Yang, W, He, K, Zhang, J, & Guo, S 2012, 'pH-Controlled *Bacillus thuringiensis* Cry1Ac Protoxin Loading and Release from Polyelectrolyte Microcapsules', *PloS one*, vol. 7, no. 9, pp. e45233.
- Yin, Y-h, Guo, Q-m, Han, Y, Wang, L-j, & Wan, S-q 2012, 'Preparation, Characterization and Nematicidal Activity of Lansiumamide B Nano-Capsules', *Journal of Integrative Agriculture*, vol. 11, no. 7, pp. 1151-1158.
- Ziaee, M 2013, 'The effect of diatomaceous earth in combination with powder, essential oil and oil-loaded nanogels of *Carum copticum* and *Cuminum cyminum* on two species of stored-product pests', PhD thesis, Tarbiat Modares University, Tehran-Iran.

A REVIEW OF PLANT ESSENTIAL OILS AS A COMPONENT OF INTEGRATED PEST MANAGEMENT IN STORED PRODCUTS PROTECTION

Masumeh Ziaee^{1*}, and Fatemeh Hamzavi²

¹ Department of Plant Protection, Faculty of Agriculture,
Shahid Chamran University of Ahvaz, Ahvaz-Iran.

² Department of Entomology, Faculty of Agriculture, Tarbiat Modares University,
Tehran, Iran.

* Corresponding author email: masumeh_ziaee@yahoo.com

ABSTRACT

Chemical pesticides cause hazardous effects to animal and human health, to non-target species, to beneficial organisms and to the environment. There have been several studies on alternative substances with insecticidal activity, such as essential oils from plants on stored product insect pests. Essential oils have fumigant, contact toxicity, oviposition deterrent, growth inhibitory, antifeedant and repellency effects on insect species. They are of natural origin, do not persist in the environment and insect resistance may develop slowly. They can be safe, non-toxic and have many industrial benefits. Essential oils have been shown to be effective in combination with natural enemies, synthetic insecticides, CO₂, diatomaceous earth, pathogenic fungi and gamma radiation against some stored product insect pests. Therefore, they can be applied as a part of integrated pest management (IPM) programs for stored products protection. Essential oils contain different constituents, and the insecticidal toxicity of some of them has been identified, e.g. 1,8-cineole as main component of Eucalyptus spp. essential oils are toxic against different insect species. The efficacy of 1,8-cineole can be enhanced by reduction in atmosphere pressure or combination with different concentration of CO₂. Application of essential oils in combination with other substances or strategies in IPM programs is more cost-effective and can also improve agricultural conditions particularly for organic food productions. This study describes an improvement in insect control practices directed against feeding insect by integration based essential oils and other manner that can serve for controlling insect pests.

Keywords: Control, Essential oils, Insect pests, integrated pest management.

INTRODUCTION

Fumigants are widely applied for controlling stored-product insect pests in many storages and silos because of their ability to eradicate a broad range of pests and their easy penetration into the commodities with minimal chemical residues (Mueller, 1990). Among them, methyl bromide (MeBr) and phosphine (PH₃) are widely used. However, their application will be restricted in the future. So the alternative agents of fumigants seem to be essential. Plant products, such as essential oils and their components were used for

fumigation since it is believed that extracts of plants may have an advantage value over conventional fumigants in terms of low mammalian toxicity, rapid degradation and local availability (Rajendran & Sriranjini, 2008). Weaver and Subramanyam (2000) suggested that the fumigant activity of botanicals could have a greater potential use than synthetic fumigants in future on the basis of their safeness, insecticidal efficacy, economic value and the use in large-scale storages. Essential oils are potential sources of alternative compounds to currently used fumigants. Various studies have demonstrated fumigant activity of different essential oils and their constituents against several species of stored product insects (Lee *et al.*, 2003; Shaaya *et al.*, 1991; Tunç *et al.*, 2000). Essential oils have fumigant, contact toxicity, oviposition deterrent, growth inhibitory, antifeedant and repellent effects on insect species (Hamzavi *et al.*, 2011; Kéita *et al.*, 2000; Lee *et al.*, 2004; Tunç *et al.*, 2000). However, the toxicity of essential oils decreased when treated on commodity. Desirable fumigants should have low adsorption on grains as well as high toxicity to target. Lee *et al.* (2004) showed that five tested essential oils were approximately 3 and 4 times less toxic (in terms of mortality) when applied in wheat at 50% filling ratio, and up to 9 times in the case of *Eucalyptus codonocarpa* essential oil compared to tests without wheat (Blakely & McKie). Also, Hamzavi *et al.* (2011) showed low fumigant efficacy of *Eucalyptus camaldulensis* and *Callistemon viminalis* oils when treated with the stored wheat grains on *Tribolium confusum* Jacquelin du Val. The presence of grain on the effectiveness of cineole and other EOs as well has been evaluated (Lee *et al.*, 2004; Rozman *et al.*, 2008; Shaaya *et al.*, 1997). They concluded that cineole and other EOs were significantly less effective when combined with wheat grains and may be attributed to essential oils adsorb on wheat grain surfaces. Although, plant essential oils may leave persistent odor and when applied at high dose rates could retain a strong smell and unpleasant taste on food (Benkeblia, 2004; Kéita *et al.*, 2000; Liu & Ho, 1999); however, these natural essential oils may be safer than conventional fumigants in terms of human toxicity and the “residues” on grain may be of less concern. Combination of essential oils at low doses with other reduced risk methods or materials as an IPM program could decrease the adverse effects of essential oils such as less effectiveness of EOs in combination with grains, poor permeability which largely lessen fumigation effect, strong odor and the relatively high price of EO which make them too expensive to be adopted for wider use (Rajendran & Sriranjini, 2008; Rozman *et al.*, 2008). In this review combination of essential oils with other control agents like natural enemies (NE), synthetic insecticides, CO₂, diatomaceous earth (DE) and gamma radiation against some stored product insect pests is presented.

Integrated pest management in basis of essential oils

1. Combination of EO and NE

Application of the essential oils combined with natural enemy of the bruchid, *Dinarmus basalis* (Rond.) (Petromalidae) was examined to control *Callosobruchus maculatus* (F.) (Boateng & Kusi, 2008; Dugravot *et al.*, 2002; Sanon *et al.*, 2002). However, Hymenoptera parasitoids are often more susceptible to insecticides than their hosts (Waage, 1989; White & Sinha, 1990; White *et al.*, 1986) and chemical treatments could adversely affect

biological control agents by reducing their population. Different findings indicated that EO reduces the density and diversity of natural enemies in storages (Boateng & Kusi, 2008; Dugravot *et al.*, 2002). Effectiveness of *Eucalyptus camaldulensis* (Dehnh) and *Callistemon viminalis* (Gaertn) essential oils with *Cephalonomia tarsalis* (Ashmead), ectoparasitoides of *O. surinamensis* was investigated against this insect pest (Hamzavi, 2011) and the author concluded that wasp was more susceptible than hosts. Therefore, application of essential oils with insects parasitoids does not seem effective and practical.

2. Combination of EO and synthetic insecticides

Although the use of pesticides is one the means of protecting stored products, their adverse effects on the environment and human health, development of genetically resistant insect strains and prohibitive costs have become major concerns and thus given impetus to the search for alternative methods of pest control (Obeng-Ofori & Reichmuth, 1999). The possibility of using reduced levels of essential oils and plant products in combination with synthetic insecticides has been reported in some researches (Ahmed & Gardiner, 1967; Don-Pedro, 1989; Pedigo, 2002; Tembo & Murfitt, 1995). The combination of two or more control options may minimize risk and costs of chemicals, reduce resistance development against the treatments and increase effectiveness of the treatments. Don-Pedro (1989) suggested the possibility of using reduced level of some vegetable oils in combination with synthetic insecticides in simple mixtures as a means of making their use more attractive and effective against the maize weevil, *Sitophilus zeamais* Motschulsky. Yuya *et al.* (2009) investigated the combined effects of Niger seed oil and malathion dust against *S. zeamais* on maize, and concluded that the combinations have minimum effective rate(s) with adequate protection of maize. Khalequzzaman and Chowdhury (2003) reported mixing oils of different plants and pirimiphos-methyl resulted in complete protection of maize from infestations of the maize weevil for more than six months. Obeng-Ofori and Amiteye (2005) indicated that the mixtures of 1, 2 and 5 ml of edible oil per kilogram and pirimiphos-methyl at 1/16 and 1/8 of the recommended doses were highly toxic to the maize weevil. A possible reason for the enhanced toxicity and persistence of the mixed products is that oils increase the uniformity of distribution of toxicants over the grain surface, thereby increasing pick-up by the insects (Tembo & Murfitt, 1995). The oils can also slow down the rates of penetration of chemical into the grains, which may increase the probability of insect contacting a lethal dose of chemicals (Salt & Ford, 1984). Furthermore, the mixtures of essential oils and chemical improve the storage microenvironment thereby retarding insect penetration and feeding (Obeng-Ofori & Amiteye, 2005). Mixing of oils with malathion enhanced chemical toxicity and persistence resulting in higher mortality of weevils in maize grains (Abraham, 2003; Obeng-Ofori & Amiteye, 2005). The application of oil/insecticide mixtures may minimize insecticide usage and hence reduce health hazards with complete protection of stored products. Furthermore, the use of reduced rates of oils will make their utilization more economical and attractive. Treatment of grains with vegetable oil/insecticide mixtures could have important practical assurance in the parts of the world where insecticides are expensive or in short supply (Obeng-Ofori & Amiteye, 2005).

3. Combination of EO and low pressure of air

Integrated management of essential oils with physical control techniques such as reduced atmosphere pressure has potential efficacy for stored-product pest control. Toxicity of propylene oxide (PPO), an organic compound, and methyl bromide at low pressure was investigated against some stored-product insects (Donahaye & Navarro, 1989; Isikber *et al.*, 2004). Also in the other studies influence of low pressure and CO₂ on the toxicity of propylene oxide was evaluated (Isikber, 2010; Navarro *et al.*, 2004). Their results showed that the combination of propylene oxide with low pressure can provide a potential alternative to methyl bromide for quarantine treatment of commodities and cause high level of insect mortality. Their findings indicated that significant differences was observed between treatments of methyl bromide alone and mixed of MeBr with CO₂ and reduced pressure. Abdolmaleki *et al.* (2010) stated that toxicity of 1,8-Cineole was enhanced at low pressure against two most common stored-product insects, *C. maculatus* and *Tribolium castaneum* (Herbst). Toxicity of 1,8-Cineole at reduced pressures was strongly influenced by ambient time. Reduced pressure or vacuum causes low O₂ and high CO₂ concentrations by metabolic arrest and losses water through opened spiracle is lethal for insects (Mitcham *et al.*, 2006; Phillips & Throne, 2010). Therefore, effect of 1,8-Cineole in reduced pressures will be more than normal pressure. This occurrence was conducted due to opening insect's spiracles and increase the rate of respiration to gain appropriate O₂ for perform enough metabolism to be alive (Mitcham *et al.*, 2006). 1,8-Cineole was found to be effective against tested insects; however, it was less toxic than methyl bromide and phosphine. The use of low pressure appears to have synergetic effect on insect's mortality.

4. Combination of EO and CO₂

Carbon dioxide is a known adjuvant for fumigants. Including or combining CO₂ with fumigants will increase the toxicity of the fumigant, improve the distribution pattern, reduced the amount of harmful chemical residues in the treated commodity and eliminate the flammable risk of fumigants (Isikber, 2010), and also the addition of CO₂ to methyl bromide resulted in an increase in the mortality of some stored-product insects (Calderon & Leesch, 1983; Williams, 1985). Laboratory tests with essential oils have shown a similar joint action with CO₂ atmospheres. Shaaya *et al.* (1997) demonstrated enhanced toxicity of the essential oil SEM76 (Lamiaceae), in the presence of CO₂ against *T. castaneum*, *Plodia interpunctella* Hübner, *Rhyzopertha dominica* (F.), *Sitophilus oryzae* (L.) and *Oryzaephilus surinamensis* (L.). In the other research Wang *et al.* (2001) reported that the peel oils of *Citrus* spp. and *Eucalyptus citriodora* Hook were more toxic in the presence of controlled atmospheres against psocid, *Liposcelis bostrychophilus* Badonnel. Fumigant toxicity of garlic essential oil alone and in combination with carbon dioxide on adults and pupae of *T. confusum* and *Ephestia kuehniella* Zeller indicated that garlic essential oil in combination with 92% CO₂ had 4.9-fold reduction in LC₉₀ values for adults of *T. confusum* compared with garlic essential oil alone. These results indicated that CO₂ has a synergistic effect on the test insects when exposed together with garlic essential oil. In conclusion, the use of high concentration of CO₂ appears to have the synergistic effect on these species as evidenced by significant decrements in LC₅₀ and LC₉₀ values. Therefore, combination of

essential oil with CO₂ can be potential as an alternative application to the most commonly used commercial fumigants, methyl bromide and phosphine (Isikber, 2010).

5. Combination of EO and DE

Plant essential oils (EO) and diatomaceous earths (DE) are natural alternatives to chemicals that are increasingly being investigated and recognized as potential components of integrated pest management (IPM) of stored products. Garlic essential oil in combination with Saiwei brand DE significantly reduced the concentration of oil required for an effective control of stored product insect pests. Results showed that the application rate of DE reduced when combined with garlic essential oil with half of the recommended rate of the commercial product being effective (Yang *et al.*, 2010). This amount is also lower than that of other DE commercial products reported (Arnaud *et al.*, 2005; Athanassiou *et al.*, 2005; Chanbang *et al.*, 2007; Korunic & Fields, 2006; Ziaee & Moharrampour, 2012). Increased in adult's stresses through the contact with the oil-treated substrate could be the reason for more vulnerable to DE.

6. Combination of EO and gamma radiation

Irradiation is another method that could enhance the effectiveness of EO. The combination of gamma radiation with an essential oil from *Perovskia atriplicifolia* (Benth) on *T. castaneum* indicated a significant synergistic effect of exposure to gamma radiation and essential oil. This combination of irradiation would have a low environmental impact and high compatibility with the essential oil (Ahmadi *et al.*, 2008).

CONCLUSION

The aforementioned studies with insects convincingly demonstrates the combination effects of EO and their chemical constituent with other control techniques for controlling storage pests. In most cases the combination of EO with other control substances seems to be synergistic except for the combination of EO and natural enemies that has not selective effect on them and has the same influence on all of the insects. Perhaps the most attractive aspect of using essential oils as integrated pest management is their low mammalian toxicity and safety which are known as green pesticides.

REFERENCES

- Abdolmaleki, A, Saferalizadeh, M, H , & Safavi, SA 2010, 'Mixed effects of 1,8-Cineole, botanical constituent, and reduced atmosphere pressure on stored products beetles in laboratory condition', *Munis Entomology and Zoology*, vol. 5, no., pp. 1040-1047.
- Abraham, T 2003, 'Studies on some non-chemical insect pest management options on farm stored maize in Ethiopia', Ph.D. Dissertation, Justus-Liebig-University of Giessen, Germany.

- Ahmadi, M, Moharrampour, S, Mozdarani, H, & Negahban, M 2008, 'Combined effect of gamma radiation and *Perovskia atriplicifolia* for the control of red flour beetle, *Tribolium castaneum*', *Communications in Agricultural and Applied Biological Sciences*, vol. 73, no. 3, pp. 643-650.
- Ahmed, H, & Gardiner, BG 1967, 'Effect of mineral oil solvent on the toxicity and speed of action of malathion', *Nature*, vol. 214, no. 5095, pp. 1338-1339.
- Arnaud, L, Tran Thi Lan, H, Brostaux, Y, & Haubruge, E 2005, 'Efficacy of diatomaceous earth formulations admixed with grain against populations of *Tribolium castaneum*', *Journal of Stored Products Research*, vol. 41, no. 2, pp. 121-130.
- Athanassiou, CG, Vayias, BJ, Dimizas, CB, Kavallieratos, NG, Papagregoriou, AS, & Buchelos, CT 2005, 'Insecticidal efficacy of diatomaceous earth against *Sitophilus oryzae* (L.) (Coleoptera: Curculionidae) and *Tribolium confusum* du Val (Coleoptera: Tenebrionidae) on stored wheat: influence of dose rate, temperature and exposure interval', *Journal of Stored Products Research*, vol. 41, no. 1, pp. 47-55.
- Benkeblia, N 2004, 'Antimicrobial activity of essential oil extracts of various onions *Allium cepa* and garlic *Allium sativum*', *LWT-Food Science and Technology*, vol. 37, no. 2, pp. 263-268.
- Boateng, B, & Kusi, F 2008, 'Toxicity of jatropha seed oil to *Callosobruchus maculatus* (Coleoptera: Bruchidae) and its parasitoid, *Dinarmus basalis* (Hymenoptera: Pteromalidae)', *Journal of Applied Sciences Research*, vol. 4, no. 8, pp. 945-951.
- Calderon, M, & Leesch, JG 1983, 'Effect of reduced pressure and CO₂ on the toxicity of m bromide to two species of stored-product insects', *Journal of Economic Entomology*, vol. 76, no. 5, pp. 1125-1128.
- Chanbang, Y, Arthur, FH, Wilde, GE, & Throne, JE 2007, 'Efficacy of diatomaceous earth and methoprene, alone and in combination, against *Rhyzopertha dominica* (F.) (Coleoptera: Bostrichidae) in rough rice', *Journal of Stored Products Research*, vol. 43, no. 4, pp. 396-401.
- Don-Pedro, KN 1989, 'Mechanisms of action of some vegetable oils against *Sitophilus zeamais* motsch (Coleoptera: Curculionidae) on wheat', *Journal of Stored Products Research*, vol. 25, no. 4, pp. 217-223.
- Donahaye, E, & Navarro, S 1989, 'Sensitivity of two dried fruit pests to methyl bromide alone, and in combination with carbon dioxide or under reduced pressure', *Tropical Science*, vol. 29, no. 1, pp. 9-14.
- Dugravot, S, Sanon, A, Thibout, E, & Huignard, J 2002, 'Susceptibility of *Callosobruchus maculatus* (Coleoptera: Bruchidae) and its parasitoid *Dinarmus basalis* (Hymenoptera: Pteromalidae) to sulphur-containing compounds: consequences on biological control', *Environmental Entomology*, vol. 31, no. 3, pp. 550-557.

- Hamzavi, F 2011, 'Insecticidal Effects of Essential oil from *Eucalyptus camaldulensis* Dehnh and Bottlebrush *Callistemon viminalis* Gaertn. on three Species of Stored-Product Beetles', MsC thesis, Tarbiat Modares University, Tehran-Iran.
- Hamzavi, F, Moharrampour, S, & Talebi, AA 2011, 'Fumigant toxicity of essential oils of *Eucalyptus camaldulensis* and *Callistemon viminalis* on *Tribolium confusum*', *Iranian Journal of Plant Protection Science*, vol. 42, no. 2, pp. 241-249.
- Isikber, A, Navarro, S, Finkelman, S, Azrieli, A, Rindner, M, & Dias, R 2004, '*Propylene oxide: a fumigant for quarantine purposes as a potential alternative to methyl bromide*', Paper presented at the Proceeding of Annual International Research Conference on methyl bromide Alternatives and Emissions Reductions, Orlando, FL, USA.
- Isikber, AA. 2010, '*Fumigant toxicity of garlic essential oil in combination with carbon dioxide (CO₂) against stored-product insects*', Paper presented at the Proceedings of the Tenth International Working Conference on Stored Product Protection, (27 June - 2 July 2010), Estoril, Portugal.
- Kéita, SM, Vincent, C, Schmit, JP, Ramaswamy, S, & Bélanger, A 2000, 'Effect of various essential oils on *Callosobruchus maculatus* (F.)(Coleoptera: Bruchidae)', *Journal of Stored Products Research*, vol. 36, no. 4, pp. 355-364.
- Khalequzzaman, M, & Chowdhury, FD 2003, 'Evaluation of mixtures of plant oils as synergists for pirimiphos-methyl in mixed formulations against *Tribolium castaneum* (Herbst)', *OnLine Journal of Biological Sciences*, vol. 3, no., pp. 347-359.
- Korunic, Z, & Fields, PG 2006, '*Susceptibility of three species of Sitophilus to diatomaceous earth*', Paper presented at the Proceedings of the 9th International Working Conference on Stored Product Protection, Campinas, Sau Paulo, brazil.
- Lee, B-H, Annis, PC, Tumaalii, Fa, & Choi, W-S 2004, 'Fumigant toxicity of essential oils from the Myrtaceae family and 1,8-cineole against 3 major stored-grain insects', *Journal of Stored Products Research*, vol. 40, no. 5, pp. 553-564.
- Lee, S, Peterson, CJ, & Coats, JR 2003, 'Fumigation toxicity of monoterpenoids to several stored product insects', *Journal of Stored Products Research*, vol. 39, no. 1, pp. 77-85.
- Liu, ZL, & Ho, SH 1999, 'Bioactivity of the essential oil extracted from *Evodia rutaecarpa* Hookf. et Thomas against the grain storage insects, *Sitophilus zeamais* Motsch. and *Tribolium castaneum* (Herbst)', *Journal of Stored Products Research*, vol. 35, no., pp. 317-328.
- Mitcham, E, Martin, T, & Zhou, S 2006, 'The mode of action of insecticidal controlled atmospheres', *Bulletin of Entomological Research*, vol. 96, no. 03, pp. 213-222.
- Mueller, DK. (1990). Fumigation. In A Mallis (Ed.), *Handbook of Pest Control*: Franzak and Foster Co. Cleveland.

- Navarro, S, Isikber, AA, Finkelman, S, Rindner, M, Azrieli, A, & Dias, R 2004, 'Effectiveness of short exposures of propylene oxide alone and in combination with low pressure or carbon dioxide against *Tribolium castaneum* (Herbst) (Coleoptera: Tenebrionidae)', *Journal of Stored Products Research*, vol. 40, no. 2, pp. 9-9.
- Obeng-Ofori, D, & Amiteye, S 2005, 'Efficacy of mixing vegetable oils with pirimiphos-methyl against the maize weevil, *Sitophilus zeamais* Motschulsky in stored maize', *Journal of Stored Products Research*, vol. 41, no. 1, pp. 57-66.
- Obeng-Ofori, D, & Reichmuth, C 1999, 'Plant oils as potentiation agents of monoterpenes for protection of stored grains against damage by stored product beetle pests', *International Journal of Pest Management*, vol. 45, no. 2, pp. 155-159.
- Pedigo, LP. (2002). *Entomology and Pest Management* (Third ed.). Prentice-Hall, Englewood Cliffs, NJ.
- Phillips, TW, & Throne, JE 2010, 'Biorational approaches to managing stored-product insects', *Annual Review of Entomology*, vol. 55, no., pp. 375-397.
- Rajendran, S, & Sriranjini, V 2008, 'Plant products as fumigants for stored-product insect control', *Journal of Stored Products Research*, vol. 44, no. 2, pp. 126-135.
- Rozman, V, Korunic, Z, & Kalinovic, I 2008, 'Effect of different quantities of wheat on the effectiveness of the essential oil cineole against stored grain insect pests', Paper presented at the Proceedings of the Eighth International Conference on Controlled Atmosphere and Fumigation in Stored Product, Chengdu, China.
- Salt, DW, & Ford, MG 1984, 'The kinetics of insecticide action. Part III: The use of stochastic modelling to investigate the pick-up of insecticides from ULV-treated surfaces by larvae of *Spodoptera littoralis* boisd', *Pesticide Science*, vol. 15, no. 4, pp. 382-410.
- Sanon, A, Garba, M, Auger, J, & Huignard, J 2002, 'Analysis of the insecticidal activity of methylisothiocyanate on *Callosobruchus maculatus* (F.) (Coleoptera: Bruchidae) and its parasitoid *Dinarmus basalis* (Rondani) (Hymenoptera: Pteromalidae)', *Journal of Stored Products Research*, vol. 38, no. 2, pp. 129-138.
- Shaaya, E, Kostjukovski, M, Eilberg, J, & Sukprakarn, C 1997, 'Plant oils as fumigants and contact insecticides for the control of stored-product insects', *Journal of Stored Products Research*, vol. 33, no. 1, pp. 7-15.
- Shaaya, E, Ravid, U, Paster, N, Juven, B, Zisman, U, & Pissarev, V 1991, 'Fumigant toxicity of essential oils against four major stored-product insects', *Journal of Chemical Ecology*, vol. 17, no. 3, pp. 499-504.
- Tembo, E, & Murfitt, RFA 1995, 'Effect of combining vegetable oil with pirimiphos-methyl for protection of stored wheat against *Sitophilus granarius* (L.)', *Journal of Stored Products Research*, vol. 31, no. 1, pp. 77-81.

- Tunç, I, Berger, BM, Erler, F, & Daglı, F 2000, 'Ovicidal activity of essential oils from five plants against two stored-product insects', *Journal of Stored Products Research*, vol. 36, no. 2, pp. 161-168.
- Waage, J 1989, 'The population ecology of pest-pesticide-natural enemy interactions', *Pesticides and Non-target Invertebrates* (pp. 81-94). Intercept, Andover, UK.
- Wang, J-J, Tsai, JH, Ding, W, Zhao, Z-M, & Li, L-S 2001, 'Toxic effects of six plant oils alone and in combination with controlled atmosphere on *Liposcelis bostrychophila* (Psocoptera: Liposcelididae)', *Journal of Economic Entomology*, vol. 94, no. 5, pp. 1296-1301.
- Weaver, DK, & Subramanyam, BH 2000 'Botanical Alternative to Pesticides in Stored-product', *IPM* (pp. 303- 320). Boston: Kluwer Academic Publishers.
- White, N, & Sinha, R 1990, 'Effect of chlorpyrifos-methyl on oat ecosystems in farm granaries', *Journal of Economic Entomology*, vol. 83, no. 3, pp. 1128-1134.
- White, N, Sinha, R, & Mills, J 1986, 'Long-term effects of an insecticide on a stored-wheat ecosystem', *Canadian Journal of Zoology*, vol. 64, no. 11, pp. 2558-2569.
- Williams, P 1985, 'Toxicity of methyl bromide in carbon dioxide enriched atmospheres to beetles attacking stored grain', *General Applied Entomology*, vol. 17, no., pp. 17-24.
- Yang, FL, Liang, GW, Xu, YJ, Lu, YY, & Zeng, L 2010, 'Diatomaceous earth enhances the toxicity of garlic, *Allium sativum*, essential oil against stored-product pests', *Journal of Stored Products Research*, vol. 46, no. 2, pp. 118-123.
- Yuya, AI, Tadesse, A, Azerefegne, F, & Tefera, T 2009, 'Efficacy of combining Niger seed oil with malathion 5% dust formulation on maize against the maize weevil, *Sitophilus zeamais* (Coleoptera: Curculionidae)', *Journal of Stored Products Research*, vol. 45, no. 1, pp. 67-70.
- Ziaee, M, & Moharramipour, S 2012, 'Efficacy of Iranian diatomaceous earth deposits against *Tribolium confusum* Jacquelin du Val (Coleoptera: Tenebrionidae)', *Journal of Asia-Pacific Entomology*, vol. 15, no. 4, pp. 547-553.

SCREENING OF SWEETPOTATO GENOTYPES FOR WATER STRESS RESISTANCE

Agnes C. Perey¹, Belinda A. Tad-awan²

¹Tarlac College of Agriculture, Camiling, Tarlac, Philippines

²Benguet State University, La Trinidad, Benguet, Philippines

Email: agnesperey122@gmail.com¹ and belle_tadawan@yahoo.com.ph²

ABSTRACT

Sweetpotato is a moderately drought tolerant crop, however, its production is still constrained by drought which is currently a worldwide problem limiting crop production. The study aimed to screen sweetpotato genotypes from various germplasm sources for drought resistance, determine the effect of water stress on the growth and yield of the genotypes, evaluate the growth and yield of selected sweetpotato genotypes for drought resistance under greenhouse condition, and determine the interaction effect of sweetpotato genotypes and levels of water stress. Forty sweetpotato genotypes were exposed to two (2) levels of water stress (no stress and moderate drought stress under ambient condition (27 °C). Results showed ten genotypes (NSIC 23, NSIC 31, Taiwan D, JOG 11-10, JK 7-1, JK 18-4, JK 23-1, BSU #1, MBE-SP and Inubi-CA) had drought resistant characteristics such as low leaf shedding, low drought score, high recovery rating, relative water content, small leaf area per plant, leaf area index, vigorous plants, more roots, longer shoot length increment and longest roots. These ten sweetpotato genotypes were further evaluated for drought resistance under greenhouse condition. Genotype Inubi-CA exhibited the lowest drought score and highest recovery rating. It also produced the longest vines at 70 and 105 DAP, highest leaf area index at 35 DAP, heaviest vines and most number of vine cuttings. Out of the 10 genotypes, five genotypes (JOG 11-10, JK 18 - 4, Taiwan D, NSIC 23 and Inubi-CA) were observed to have the characters for stress resistance such as small leaf area and leaf area index, long roots, low drought score, high recovery rating and more vine yield. Leaf area at 65 DAP and root weight were positively correlated with vine yield. Conversely, drought score was negatively correlated with vine yield.

Keywords: genotypes, drought resistance, greenhouse

INTRODUCTION

Sweetpotato is rank second as staple food crop for people living in rural areas, hilly regions and coastal plains of Philippines. Production of quality storage roots of sweetpotato is important to sustain the emerging population in the area. However, farmers have difficulties in producing quality storage roots during summer due to production constrains such as genotypes, water and temperature.

Drought is a worldwide problem, seriously limiting global crop production. Recently, global climate change has made this situation more serious (Pan, 2002). Water stress is

one of the most common environmental stresses affecting plant growth and productivity (Boyer, 1982). Plant water stress, is often caused by drought and can have major impacts on plant growth and development. When it comes to crops, plant water stress can be the cause of lower yields and possible crop failure (Onyilagha, 2008).

The main consequence of water stress is decreased growth and development caused by reduced photosynthesis. Photosynthesis is the process by which plants combine water, carbon dioxide and light to make carbohydrates for energy. Chemical limitations due to reductions in critical photosynthetic components such as water can negatively impact plant growth (Farkas, 2004).

Sweet potato is considered to be moderately drought tolerant (Valenzuela *et al.*, 2000). However, drought is often a major environmental constraint for sweetpotato production in areas where it is grown under rainfed condition (Anselmo *et al.*, 1998).

Thus, this study was conducted to screen and evaluate sweetpotato genotypes for water stress

MATERIALS AND METHODS

This study was composed of two experiments, first was the screening of 40 sweetpotato genotypes using the Uni-green technique under room temperature (Uni-green technique is a technique of screening a drought resistant plant using Polyethylene Glycol(PEG) where in single nodes of sweet potato were used s planting materials and planted to a floral foam. Floral foam composition is nontoxic, environmentally friendly, has improved absorption/adsorption and retention of liquids, is not as hard as prior art foams, does not include polymerization by products detrimental to flower and plant life.); and the second is the evaluation of ten selected genotypes for drought resistance under greenhouse condition. The experiment was conducted in sweet potato growing area in Paniqui, Tarlac, Philippines from January to November, 2012.

A. Experiment 1. Screening of Sweetpotato Genotypes using Uni-green Technique

1. Experimental design and Treatments

A 40 x 2 study was laid out in completely randomized design (CRD) and replicated three times.

Factor A consisted of 40 genotypes

Factor B level involved the two of water stress or soil matric potential

L₁ normal condition (20 cb)

L₂ moderate stress (60 cb)

Soil moisture potential (SMP) in centibars (cb) was measured with the use of an irrrometer, operating similarly on the tensiometer principle.

Floral foam measuring 2.5cm x 3.5cm x 2.75cm with a weight of 0.71g was used as a medium or holder. About 31.5 ml of purified water was used to water each holder. The weight of the floral foam after watering was 26.16g. Sterilized single nodes of planting

materials were planted in the floral foam. Planted single node cutting were maintained in a seedling tray for two months.

The fertilization recommendation of 20 N- 20 P₂O₅- 20 K₂O was used as foliar fertilizer at a rate of 70 g per liter of water.

Irrigation was done everyday before the drought stress imposition.

Spraying of pesticide was done three weeks after planting.

2. Drought stress imposition

A month after planting or when the plantlets had about 7cm of roots and shoots with at least three nodes, the plantlets were immersed in purified water with 20 mg⁻¹ of polyethylene glycol 4000 (PEG) for 5 minutes on the first day of treatment. In the succeeding days, immersion was reduced to 2 minutes. Immersion was done twice.

B. Experiment 2. Evaluation of Selected Genotypes for Drought Resistanc under Greenhouse Conditions

Ten selected sweetpotato genotypes derived from Experiment 1 were used to further evaluate their drought resistance under greenhouse condition. The characteristics of the 10 sweetpotato genotypes considered drought resistant are presented in Table 2.

Table 2. Ten genotypes selected from Experiment 1 with their morphological, physiological and growth characteristics

GENOTYPE	LEAF AREA (cm ²)	DROUGHT SCORE*	RELATIVE WATER CONTENT (%)	ROOT NUMBER	LENGTH OF ROOTS (cm)
BSU # 1	23.97	1.00	31.48	17.00	8.30
JK 7-4	56.78	1.00	28.92	12.00	7.97
JK 18 -4	23.97	1.00	27.43	11.00	8.18
JK 23 -1	32.17	1.00	20.68	9.00	8.81
JOG 11-10	20.19	1.00	33.96	19.67	7.86
MBE-SP	92.74	1.00	43.73	8.00	10.27
NSIC- 23	32.80	1.00	32.35	10.00	7.44
NSIC- 31	101.57	1.67	29.60	7.33	5.24
Taiwan -D	26.50	1.00	30.55	9.00	7.34
UBE- CA	34.07	1.00	29.19	10.00	

* Rating scale: 1-no stress; 3-30% of the leaves wilted; 5- 50% of the leaves wilted; 7-80% of the leaves wilted ; 9 – complete wilting

1. Experimental Design and Treatments

A 10 x 3 factor factorial in randomized complete block design was used and replicated three times.

Factor A	Sweetpotato Genotypes
Factor B	Level water stress

L₁ - control /normal (20 cb)

L₂ - moderate stress (60 cb)

L₃ - severe stress (80 cb)

2. Crop establishment and maintenance

Plantlets of selected genotypes were planted in 8 x 8 x 14 inches polyethylene bags. The polyethylene bags were filled with a 12 kg mixture of three parts of sandy loam soil (sterilized) and one half part vermicompost (3:0.5). Plantlets were irrigated after planting. To ensure growth and development, fertilization was done using complete fertilizer (14 N -14 P₂O₅-14 K₂O) at 15 g per bag in a split application where 5 g was applied at planting and 10 g one month after planting. Spraying with pesticide was done to control the pests and diseases.

3. Drought imposition

All treatment combinations were watered regularly and evenly with two liters of water per bag for four weeks until the plants were established. Soil moisture potential was measured with the use of an irrometer.

From the initial reading of 20 cb (normal), watering was withheld until SMP was dropped to 60 cb and 80 cb then watering was done; to attain (60 cb) and 80 cb) 1500 l and 2100 ml of water, respectively, were added. The procedure was repeated for several cycles up to one week before harvesting.

4. Statistical Analysis

All data were tabulated and analyzed using the appropriate analysis of variance for two factor factorial in Completely Randomized Design for Experiment 1, two factor factorial in Randomized Complete Block Design for Experiment 2. Significance among treatment means was analyzed using the Duncan's Multiple Range Test (DMRT). Correlation analysis was also done.

RESULTS AND DISCUSSION

A. Experiment 1. Screening of Sweetpotato Genotypes using Uni-green Technique

1. Number of Stomates on the Abaxial and Adaxial Portion of Leaves

Significant differences among genotypes on the number of abaxial and adaxial portion of the leaves. Genotype JK-18-4 had the highest number of stomates per cm² with a mean of 140 while the least was observed in genotype UPLSP-3 with a mean of 51.75 on the abaxial portion of the leaves.

Genotypes UPLB-SP 4 had the most number of stomates per cm² with a mean of 19.50 while the least was observed from NSIC 31 with a mean of 13.18. Stomata number is a

genotype characteristic but the stomatal opening and closing are more important to affect transpiration (Jose and Tad-awan, 2008).

Number of stomates on the abaxial and adaxial portion of leaves was significantly affected by level of water stress. In all genotypes, subjecting to moderate stress condition increased the number of stomates with a mean of 91.16 and 16.84, respectively while genotypes not stressed showed lesser number of stomates with a mean of 83.26 and 16.34, respectively. The stomatal size obviously decreases with water deficit, and stomatal density was positive correlated with stomal conductance net CO₂ assimilation rate and water use efficiency (Xu and Zhou, 2008).

There were significant interaction between the genotypes and level of water stress on the number of stomates on the abaxial and adaxial portion of the leaves. JK18-4 under moderates stress had the highest number of stomates with a mean of 143.67 for abaxial portion of the leaves. UPLB SP-4 under moderate stress had the most number of stomates per cm² on the adaxial portion of the leaves with a mean of 19.53. The lowest was observed from UPLSP-3 under normal condition with a mean of 50.00

2. Leaf Characteristics

Thirty eight genotypes exhibited planophyle leaf orientation and two genotypes (Japanese-Inube and JK 23-1) had erectophyle leaf orientation. Erectophyle leaf orientation was noted to be efficient in intercepting solar radiation.

Most of the genotypes' reaction to water deficit were shedding and dropping. Genotypes UPLB SP 5, Taiwan N, JK 7-4 and JK 18-4 had dropping leaves as a response to water deficit. This conforms with the study of Amthor (2005) that dropping, shedding and curling are crop responses to high temperature and limited irrigation to reduce transpiration.

3. Leaf Area at 35 DAP

Genotypes significantly different on their leaf area. Genotype NSIC 28 had the largest leaves with a mean of 114.28cm² followed by Taiwan D with a mean of 94.95cm² while the smallest leaves were noted from Super Bureau B with a mean of 18.13 cm². The large leaf of NSIC 28 could be a mechanism to endure drought stress. According to Del Ocampo (2002) the capacity to form leaves and sensitivity of leaf development in response to water stress were apparently under genetic control.

Significant effect of the level of water stress was noted on the area per leaf. Leaf area of the genotypes under normal condition were higher than under moderate stress (60 cb) with a mean of 43.87 and 36.73% respectively. This could be attributed to the effect of water stress on leaf expansion. Insufficient water supply inhibits cell division and expansion resulting in the production of smaller leaves (ICPRE and UI-CALS, 2002; Pritchard and Amthor, 2005).

Leaf area was significantly affected by the interaction of genotypes and level of water stress. Genotypes under moderate stress had smaller leaves than the genotypes under not stressed. Water stress during the vegetative stage inhibits both cell expansion and division leading to reduced leaf area resulting to the production of smaller leaves,

reduced vine and root expansion, plant height, and delays canopy development but tends to acclimate the plant to water stress (IICPRE and UI-CALS, 2002).

4. Root Length

Root length of genotypes significantly different among the genotypes. Genotype JK 23-1 significantly produced the longest roots with a mean of 10.95 cm but comparable with NSIC 23 with a mean of 9.37 followed by Inubi – CA with a mean of 8.91cm. Longest roots of the genotypes may be a mechanism to endure water stress.

Length of roots was significantly affected by the level of water stress. Longer roots were observed from genotypes under normal condition than genotypes under moderate stress condition (60 cb) with a mean of 7.77 cm and 6.46 cm, respectively. Trachsel *et al.*, (2011) found that plants exposed to water stress led to the reduction in elongation rates of lateral roots.

Genotypes and level of water stress significantly interacted to affect the length of roots. The longest roots were observed from genotype NSIC 23 under normal condition (20 cb) with a mean of 9.92 cm while the shortest roots were observed from genotype Inubi B under moderate stress condition (60 cb) with a mean of 4.19 cm. Thangadurai *et.al.*, (2007) cited that many plant species are able to increase water uptake efficiency by developing deep and extensive root system under period of drought.

5. Length of Shoots Increment after Drought Imposition

Results show significant differences among the different genotypes. All genotypes exhibited increased in shoot length except for Super Bureau N. The longest shoots after stress imposition were observed from UPLB SP 2 with a mean of 23.38 cm and the shortest shoots were measured from Taiwan D with a mean of 9.29 cm. Reduced shoot growth could be a mechanism of crops to endure water stress. Dami (1995) found that tobacco plantlets treated with PEG showed reduction in shoot growth and lack of roots.

Shoot length was significantly affected by water stress level. The longest shoots after stress imposition were observed from genotypes under normal condition with a mean of 16.66 cm while the shortest shoots were observed from genotypes under moderate stress with a mean of 15.12 cm. According to Fernandez *et al.*, (1997) there was a consistent shoot length reduction due to drought stress.

Shoot length significantly differed among the genotypes at different water stress level. Genotypes UPLB-SP2 and JK 18-4 under normal condition exhibited the longest shoots with a mean of 23.29 cm and 21.60 cm, respectively. Shortest shoots were observed from Taiwan D under moderate stress (60 cb) with a mean of 6.64cm. This conforms with the findings of Kirnak *et al.* (2001) in eggplants showing that water stress reduced both stem height and internode diameter by 46% to 51% under 40 % field capacity.

6. Drought Score

Drought score significantly differed among the genotypes. Lowest drought score were observed in genotypes NSIC 23, NSIC 31, Taiwan D, JOG 11-10, JK7-4, JK 23-1, BSU #1, MBE –SP and Inubi- CA had rating ranging from 0.99 to 1.00 or no stress. Low

drought score means there was no stress observed or were turgid in all the plants observed. This might be due to the long roots of these genotypes which can absorb more water under limited water supply and wide leaves to conserve moisture by covering the soil to minimize soil evaporation.

Significant differences in drought score as affected by level of water stress. Plants under moderate stress had higher drought score rating of 3.30 while lower drought score was observed from the un stress with a rating of 0.99 to 1.00. Low drought could be attributed to the available water on a saturated soil (20 cb).

Genotypes and level of water stress interacted significantly to affect drought score. Genotypes NSIC 23, NSIC 31, Super Bureau N, JOG 11-10, JK 7- 4, JK-18- 4 ,JK 23-1, BSU #1, MBE –SP and Inubi–CA subjected to moderate stress had the lowest drought score of 1.00 or no stress and the highest drought score was observed from Super Bureau B and Taiwan R with a drought score of 8.99 or complete wilting and death of plants. This could be attributed to the characteristic of Super Bureau B of producing roots slowly. Salim (2010) found that shoot/root ratios consistently decrease under drought stress, which is a universal expression of adaptation.

7. Relative Water Content (RWC)

Significant differences were observed on the RWC of the different genotypes. Highest RWC was recorded from JK 23-1 (44.02%) but comparable with Haponita (43.40%). The lowest RWC was obtained from NSIC 28 with a mean of 17.65%. This could be attributed to the characteristic of the leaves to absorb more water than other genotypes. Plants were able to regain turgidity to certain extent Laurel *et al.*, (2009).

RWC of plants was significantly affected by the level of water stress. Plants at 35 DAP under normal condition had lower RWC with a mean of 25.98% while the higher RWC was observed from plants under moderate stress with a mean of 28.68%. Significant interaction of genotypes and level of water stress was observed on RWC at 35 DAP. Genotype Super Bureau N subjected to moderate stress had the highest RWC (44.61%) while the lowest RWC was observed from NSIC 28 subjected to moderate stress with a mean of 15.59%. This conforms with the study of Rai (1989) on bush beans subjected to water deficit which showed a significant reduction of RWC of the leaves.

8. Plant Height

Plant heights at 10,20,30,40 and 50 DAP were significantly different among genotypes. Genotype JK 18-4 registered the tallest plants at 10 DAP with a mean of 9.63cm, while the shortest plants were observed from Taiwan R with a mean height of 5.09 cm and Super Bureau at 20 DAP with a mean height of 5.92cm.

The tallest genotypes at 30,40 and 50 DAP were observed from UPLB SP 2 with a mean of 21.31 cm, 25.42 cm and 29.53 cm, respectively Shortest plants were obtained from Taiwan N with a mean height of 8.32 cm, 10.15 cm and 12.08 cm, respectively.

Plant heights at 10,20,30,40,and 50 DAP were significantly affected by the level of water stress. Plants under normal condition produced taller plants with a mean of 6.82 cm, 12.99 cm, 19.03 cm and 23.83 cm for 10,20, 40 and 50DAP, respectively while at

30 DAP plants under moderate stress registered the tallest plants with a mean of 14.50 cm.

B. Experiment 2. Evaluation of Selected Genotypes for Drought Resistance under Greenhouse Condition

1. Meteorological Data

The greenhouse air temperature during the growing period ranged from 19 °C to 43 °C. The highest temperature was observed in July with 43 °C, while the lowest air temperature was observed in October with 18 °C. The high temperature of 43 °C recorded was beyond the temperature requirement of sweet potato. According to Romero *et al.*, (1991), sweet potato plants grow with temperatures between 15°C and 35°C and that lower and higher temperatures have detrimental effects on yield. This condition may explain the absence of storage roots of the genotypes evaluated in this study.

2. Number of Stomates on the Abaxial and Adaxial Portion of Leaves

Significant differences among the genotypes existed on the number of stomates. Genotype JOG 11-10 had the most number of stomata ^{per}cm² with a mean of 128.33 and 20.2, respectively while the least was observed from genotype NSIC 31 with a mean of 85.33 and 3.80, respectively.

Number of stomates was significantly affected by the level of water stress. Genotypes under moderate stress condition showed the most number of stomates ^{per}cm² in the abaxial and adaxial portion of the leaves with a mean of 91.16 and 16.84, respectively while the lowest was observed from un stress with a mean of 83.26 and 16.34, respectively. Results of studies show that water deficit leads to an increase in stomatal density (McCree and Davis, 1974; Cutler *et al.*, 1977; Yang and Wang, 2001; Zhang *et al.*, 2006).

There was a significant interaction of genotypes and level of water stress. Genotype JOG 11-10 under moderate stress registered the most number of stomates ^{per}cm² on the adaxial and abaxial portion of the leaves with a mean of 175.00 and 26.25, respectively while genotype JK 18-4 under control condition had the least with a mean of 79.00 and 11.84, respectively. This confirms with results of Xu and Zhou (2008) on wheat that moderate water deficits had positive effects on stomatal number, but more severe deficits led to a reduction of stomata.

3. Leaf Orientation

Thirty nine genotypes exhibited planophyle leaf orientation and only genotype JK-23-1 had erectophyle leaf orientation. Erectophyle leaf orientation was noted to be efficient in intercepting solar radiation.

4. Leaf Reaction to Moisture Deficit

Leaves of all genotypes responded to water deficit through shedding and dropping. This conforms with the study of Noogle and Fritz (1983) that drooping and sagging of plant tissues especially leaves known as wilting which is due to change in elastic properties of cell walls when turgor pressure declines below a certain critical value.

5. Drought Score

Significant differences were observed on the drought scores of the different genotypes. Genotype Inubi-CA registered the lowest drought score of 2.33 but comparable with Taiwan D, NSIC 31, and BSU # 1 with 2.56 drought score. These genotypes have comparable drought score (2.33) with Inubi-CA. Low drought score may be attributed to mechanism that help in absorbing sufficient water to maintain leaf turgidity during water stress condition. One mechanism could be the production of pubescence in the leaves which was exhibited by Inubi – CA.

Significant difference was observed on the drought score of the plants as affected by level of water stress. Genotypes under severe stress (80 cb) exhibited the highest drought score of 5.87 and genotypes under moderate stress condition had comparable drought score with plants under normal condition with drought score of 3.20 and 1.33, respectively. It was also observed that plants in the normal condition or sufficient water showed wilting of leaves. This could be attributed to the high temperature (39-43°C) inside the greenhouse.

Genotypes and level of water stress interacted significantly to affect drought scores. Genotypes under normal condition (20 cb) had the lowest score ranging from 1.00 to 1.67 while severe stress had a highest drought score of 8.33. High drought score is due to the depletion of water needed for turgidity brought about by water stress and high temperature during conduct of the study.

6. Relative Water Content (RWC)

RWC of the different genotypes did not differ at 35 DAP. Highest RWC was obtained from genotypes JK 23-1 with a mean of 63.64% while the lowest was observed from Inubi-CA with a mean of 32.81%.

No significant differences were observed among the levels of water stress on RWC. Highest RWC of 44.02% was recorded from JK23-1 but comparable with Haponita. The lowest RWC was obtained from NSIC 28 with a mean of 17.65%. This could be attributed to the characteristic of the leaves to absorb more water than other genotypes.

Results show no significant interaction of genotypes and level of water stress on RWC at 35 DAP.

7. Net Assimilation Rate

Net assimilation rate (NAR) of the different genotypes was greatly affected at 35, 50 and 65 DAP. NSIC 23 exhibited the highest NAR with a mean of 3.96% but not significantly different with JK-18-4 with a mean of 3.89%. Genotype JOG 11-10 had

comparable NAR (3.69%) with NSIC 23 and JK-18-4. The lowest NAR was observed from BSU#1 with a mean of 2.33%.

The NAR of all genotypes at 65 DAP were increased. JK 18-4 had the highest NAR (5.84%) which not significantly different with JK 7-4 (5.79%), JOG 11-10 (5.46%), Inubi-CA (5.07%) and JK 23-1 (5.05%) had comparable NAR with JK18-4. Results indicate that all genotypes had an increased dry weight accumulation per unit area of assimilate per unit of time.

Significant difference were noted on NAR of the plants as affected by level of water stress. NAR of all genotypes decreased with increasing water stress at 35, 50 and 65 DAP. Lowest NAR was observed from genotypes under severe stress with a mean of 2.54% while the highest NAR was observed from plants under un stress with a mean of 3.78%. Based on the study of Van Heerden (2008), restricted water supply leads to inhibition of CO₂ assimilation and photosynthesis through stomatal closure. Further, drought stress decreased leaf area duration, cumulative water transpired, net assimilation rate (Simane *et al.*, 1993).

The interaction of genotypes and level of water stress did not significantly affect the NAR at 35, 50 and 65 DAP.

8. Vine length

Vine length significantly varied at 35, 70 and 105 DAP among the different genotypes. Genotype JK 7- 4 exhibited the longest vines with a mean of 146.87 cm but not significantly different with genotypes JK 23-1, NSIC 23, BSU # 1, and Inubi- CA with a mean of 146.69cm, 138.82cm, 138.00cm, 132.58cm, respectively. The shortest vines were observed from JK 18-4 with a mean of 62.82 cm.

Genotypes BSU # 1 exhibited the longest vines with a mean of 260.83 cm at 70 DAP while the shortest was observed from JK 18-4 with a mean of 162.64cm.

At 105 DAP genotype Inubi-CA registered the longest vines with a mean of 391.80 cm but not significantly different with BSU # 1(391.24cm) while the shortest was observed from JK 18-4 with a mean of 162.64cm.

Vine length at 35DAP was not significantly affected by the level of water stress.

Vine length at 70 and 105DAP were significantly affected by level of water stress. The longest vine at 70 DAP was observed from plants under severe stress condition with a mean of 340.97cm followed by plants under moderate stress with a mean of 223.05cm and the shortest vine was observed from plants under control condition (205.63cm).

Significantly affected by level of water stress on the on the vine length at 105 DAP. Genotypes under moderate stress had the longest vines with a mean of 341.95 cm while the lowest was observed from genotypes under control condition with a mean of 286.61cm. Vine length is primarily a genotypic characteristic (OSU, 1997), however, different genotypes have different sensitivity to the environment. For instance Jk18-4 produce short vines to conserve water, thus coping with water stress. Other genotypes produce long vines also a coping mechanism by more roots per node as the vine creeps on the ground.

The interaction of genotypes and level of water stress did not significantly affect the vine length at 35, 70 and 105 DAP.

9. Vine Weight per Plant

Vine weight was significantly different among the genotypes. The highest vine yield was observed from genotype NSIC 31 with a mean of 842.78 g followed by Inubi-CA (714.44g). Lowest vine yield was observed from JK -18-4 with a mean of 343.22g.

Vine weight was significantly affected by level of water stress. Genotypes under moderate stress registered the heaviest vine compared to genotypes under normal condition and genotypes under severe stress condition with a mean of 648.17g, 545.60g and 481.33 g, respectively.

Vine yield of plant as affected by genotypes and level of water stress. Genotype NSIC 31 produced the heaviest vines under any level of water stress while the lowest was observed from genotype JK 18-4 with a mean of 266.00 g. Other treatment combinations had vine weights ranging from 376.33 to 845.00 g.

10. Leaf Area

Significant differences were noted on the area per leaf of the different genotypes at 35, 50 and 65 DAP. All genotypes had an increase area per leaf from 35 to 65 DAP.

Genotype BSU# 1 was noted to have the highest leaf area at 35 and 50 DAP with a mean of 92.66 and 265.96, respectively. Genotypes NSIC 23 (84.04 cm), Taiwan D (83.76 cm), JK 23-1 (77.20cm), JOG 11-10 (73.16cm) and Inubi-CA (71.81cm) had comparable leaf area with BSU #1. At 65 DAP genotype Inubi- CA had the highest leaf area with a mean of 310.56 cm while the lowest leaf area was observed from JK 18-4 with a mean of 235.78cm.

Area per leaf at 35 DAP was not greatly affected by level of water stress.

At 50 and 65 DAP were significantly affect the area per leaf. Leaf area of all genotypes under different levels of water stress were increased. Genotypes under moderate registered the highest leaf area with a mean 216.24 cm and 296.95 cm at 50 and 65DAP, respectively, followed by genotypes under control condition with a mean of 260.15cm and 204.30 cm, respectively while the lowest leaf area was observed from genotypes under severe stress condition with a mean of 198.83 and 235.91 cm, respectively. Water deficit or insufficient water supply inhibits cell division and expansion resulting in the production of smaller leaves (Zaag, 1992; ICPRE and UI-CALS, 2002; Pritchard and Amthor, 2005).

Area per leaf of genotypes at 35 and 65 DAP was not remarkably affected by the interaction of genotypes and level of water stress.

11. Leaf Area Index

Genotypes significantly differ in their leaf area index (LAI) at 35, 50 and 65 DAP. All genotypes used had an increased LAI at 35, 50 up to 65 DAP having vigorous lateral

shoots. Genotypes BSU# 1 exhibited the largest LAI with a mean of 3.67 but comparable with JK-23-1 with a mean of 3.22 cm. The smallest LAI was obtained from genotype JK-18-4 with a mean of 1.44 cm at 35 DAP. This could be due to shedding of leaves and heavy infestation of cutworms.

At 50 DAP, BSU#1 had the highest LAI of 9.14 cm while the lowest was from MBE-SP and Taiwan-D with a mean of 2.66 and 2.87 cm, respectively at 50 and 65 DAP.

LAI at 35 DAP was not significantly affected by level of water stress.

At 50 and 65 DAP, highest LAI was observed from moderate water stress with a mean of 6.18 and 12.50, respectively while the lowest was observed from severe stress with a mean of 4.2 and 10.80, respectively. This shows that sweetpotato can tolerate moderate stress condition, as shown by normal leaf development. But at severe stress, leaf development is affected to an extent that leaf development is reduced. This could be attributed to the defense mechanism of having small leaves against water stress. As stated by Akyeampong (1985), drought-stressed leaves were smaller than the unstressed leaves in the case of cowpea.

The interaction of genotypes and level of water stress did not significantly affect the LAI of plants at 35, 50 and 65 DAP.

12. Root Weight at Harvest

There were significant differences on the root weight at harvest of the different genotypes. Genotype NSIC 31 produced the heaviest root with a mean of 14.06 g while the lowest was observed from genotype JK 7-4 with a mean of 4.84g. Other genotypes had the root weight ranging from 4.92 to 12.61 g.

Root weight at harvest was significantly affected by level of water stress. Genotypes under severe stress condition (80 cb) registered the heaviest roots with a mean of 8.68 g while the lowest was noted from genotypes under control and moderate stress with a mean of 6.92 g. This may be due to the mechanism of the plants of having long roots during stress. Akyeampong (1985) and Hall and Schulze (1980) found that in cowpea, increased root density and depth during stress to exploit larger volume of soil to ensure the survival of the crop during drought water stress and maintain plant status.

Genotypes and level of water stress interacted significantly to affect root weight. Genotype NSIC 31 under severe stress condition (60 cb) had the highest root weight with a mean of 15.45 g while the lowest weight was observed from genotype JK 23-1 under normal condition (20 cb) with a mean of 4.73 g.

13. Root Length at harvest

There were significant differences on the root length of the different genotypes. Genotype JOG 11-10 exhibited the longest roots with a mean of 61.44 cm while the shortest roots were obtained from NSIC 23 with a mean of 24.33 cm.

Length of roots at harvest was significantly affected by level of water stress. The longest roots were observed from genotypes under severe stress condition (60 cb) with a mean of 46.33 cm, followed by moderate stress with a mean of 37.73 cm while the

shortest roots were observed in genotypes under control condition (20 cb) with a mean of 34.70. Gurgel (2008) stated that indicators of drought tolerance is characterized by having a deep root system and ability of leaf rolling since root play an important role in controlling plant water status to avoid drought injury and leaves roll under dry conditions, exposing less leaf surface to be in contact with dry air, which was also observed during the study.

There was a significant interaction on the length of roots as affected by genotypes and level of water stress. The longest roots were observed from genotypes JK 7-4 under severe stress condition (60 cb) with a mean of 73.00 cm while the shortest roots were observed from genotypes JK 23-1 with a mean of 14.00 cm. Other treatment combinations had root lengths ranging from 15.00 to 70.67 cm.

C. Correlation of Morphological, Physiological, Growth, Incidence of Insect pest and Diseases and Vine yield Characters

The correlation coefficient between the vine yield at vine length (35, 70 and 105 DAP), leaf size (35, 50, and 65 DAP) leaf area index (35, 50 and 65 DAP) of the different physiological, growth, morphological, incidence of pest and diseases to vine yield.

Results revealed that drought score has negative significant correlation with vine yield. This implies that genotypes lesser drought score produce more vine yield. This collaborates with the findings of Nedler and Heuer (1995) that there is a direct correlation between increasing drought and reduction in yield.

Root weight has positive significant correlation with vine yield. This shows that genotypes with heavier roots have higher vine yield.

Leaf area was significantly correlated with vine yield. This implies that maintaining large leaves may help in increasing the vine yield of different sweetpotato genotypes. This coincides with the view of Stepler (1967) that among the contributory factor to high yield is the early establishment of large leaf area.

CONCLUSIONS

The study was composed of two experiments, first was screening of sweetpotato genotypes using uni-green techniques under room temperature and the second was evaluation of selected genotypes for drought resistance under greenhouse condition. The study aimed to screen and evaluate sweetpotato genotypes for water stress

Based on the results, the following conclusions are drawn:

1. Moderate water stress had negative effects on the morphological, physiological and growth performance of the forty genotypes evaluated.
2. Plantlets under moderates stress produced smallest leaf area and leaf area index, lowest drought score, high relative water content and smallest height increment.
3. Ten best genotypes were selected such as NSIC 23,. NSIC 31, Taiwan D, JOG 11-10, JK 7-4, JK 18-4, JK 23-1, BSU #1 , MBE –SP and Inubi –CA which exhibited drought resistant characteristics such as dropping and shedding of leaves, lower

drought score, higher recovery rating, high RWC, medium to small leaf area, and leaf area index and vigorous plants.

4. Plants under moderate stress and severe stress produced smallest leaf area and leaf area index, heaviest roots, longest roots and highest RWC.

Production of sweetpotato can still be feasible in soil with 60 cb soil moisture matric potential.

5. Genotypes JOG 11-10, JK 18 -4, JK 7-4, Taiwan D, NSIC 31 and Inubi -CA had drought resistant characteristics such as small leaf area and area index, longest roots, low drought score, high recovery rating and more vine yield.

Significant positive correlation between leaf area at 65 DAP and root weight with vine yield in 10 genotypes and negative significant correlation existed in drought score to vine yield.

Recommendation

Considering the findings in study, the following are recommended:

1. Genotypes NSIC 23, NSIC 31, Taiwan D, JOG 11-10, JK 7-4, JK 18-4, JK 23-1, BSU #1, MBE -SP and Inubi -CA can be planted under 60 cb soil moisture matric potential.
2. When soil matric potential is 80 cb genotypes JOG 11-10, JK 18 -1, NSIC 23, Taiwan D and Inubi -CA can be planted.
3. Characters significantly correlated with vine yield can be used as selection indices for sweetpotato genotypes under water stress condition.
4. Further studies need to be undertaken during dry season for drought resistant genotypes under field condition.

REFERENCES

- Jose, D. And B. Tad-Awan. 2008. Soil Moisture Levels On The Performance Of Potato (*Solanum Tuberosum L.*) Cultivars. Published Dissertation Thesis. Benguet State University, La Trinidad, Benguet Philippines.
- Malone Sr, Hs. Hb. Mayeux, Johnson and Hw. Polley. Stomatal Density And Aperture Length In Four Plant Species Grown Across A Sub Ambient CO₂ Gradient. American Journal Of Botany. 1993;80:1413-1418.
- Matheka, J.M., E. Magiri, A. Rasha, and J. Machuka. 2008. In Vitro Selection And Characterization Of Drought Tolerant Somaclones Of Tropical Maize (*Zea Mays L.*) Asian Network For Scientific Information. Biotechnology 7 (4): 641 -650 Issn 1682 - 296x

- Philippus , D. and V. Heerden, 2008. Effects Of Prolonged Restriction In Water Supply On Photosynthesis, Shoot Development And Storage Root Yield In Sweet Potato Physiologia Plantarum, Issue 1 2008
- Quarrie Sa, Hg. Jones. 1977. Effects Of Abscistic Acid and Water Stress On Development And Morphology Of Wheat. Journal Of Experimental Botany. 1977;28:192–203.
- Raheen, A. 2007. Monsanto’s Genetically Modified Drought Tolerant Maize In South Africa. African Centre For Biosafety
- Taisan, A. 2010. Comparative Effects Of Drought And Salt Stress On Germination And Seedling Growth Of *Pennisetum Divisum* (Gmel.) Henr. American Journal Of Applied Sciences 7 (5): 640-646, 2010 Issn 1546-9239 © 2010science.
- Vajrabhaya, M., W. Kumpun, And S. Chadchawan. 2001. The Solute Accumulation: The Mechanism For Drought Tolerance In Rd23 Rice (*Oryza Sativa L*) Lines. Scienceasia 27 (2001) : 93-97
- Xiangwen, L. 2010. Coronatine Alleviates Water Deficiency Stress On Winter Wheat Seedlings Journal Of Integrative Plant Biology, Issue 7 2010
- Xinyou, Y. 2009. Combined Measurements Of Gas Exchange And Chlorophyll Fluorescence To Estimate Parameters Of A Biochemical C3 Photosynthesis Model: A Critical Appraisal And A New Integrated Approach Applied To Leaves In A Wheat (*Triticum Aestivum*) Canopy Plant Cell & Environment, Issue 5 2009

YIELD POTENCY OF SWEET POTATO VARIETIES UNDER DROUGHT CONDITION IN SANDY LAND

Tutut Wirawati, Endah Budi Irawati, Ami Suryawati

Agrotechnology Departement, Faculty of Agriculture, UPN "Veteran" Yogyakarta

tututwirawati@yahoo.com

ABSTRACT

Sandy coastal in Yogyakarta have to develop land farming. Some problem to use its i.e soil texture, soil structure, high permeability, deficiency of nutrient essential, leaching, low soil surface, low water capacity and low nutrient essential fixation. The aim of this research was to study the cultivars of sweet potato (*Ipomoea batatas*) under drought condition in sandy land. A pot experiment was conducted from May to November 2013, in Experimental Station, Agricultural Faculty of UPNVY. It was arranged in Split Plot Design. The Main Plot was the sweet potato varieties: Beta -1, Beta -2, Papua Solossa, Sari, and Kidal. The Sub Plot was the drought condition: normal water, water stress for 1 week on 20 and 60 days after plant. Data were analyzed by anova and DMRT at 5%. The result showed that Kidal Variety had best tuber number and tuber weight. Papua Solossa variety had lower sugar and starch than another variety. Water stress had tuber number decreased but sugar and starch content increased.

Key words: *sweet potatoes, variety, water stress, sandy land*

INTRODUCTION

Sweet potato (*Ipomoea batatas* (L.) Lam.) is one of carbohydrate producer plant which has development purpose for supporting diversification of non-rice program, because sweet potato has high nutrition and contains of alpha enzyme and beta amylase which are useful for producing high maltose syrup (Rahayuningsih *et al.*, 2004). Besides, sweet potato formulated with peanuts is good for industry raw materials especially baby food industry. Sweet potato products can be projected as animal feed, biodegradable plastic raw materials industry (Antarlina, 1993).

Special Region of Yogyakarta has south beach sandy land area of 9,000 hectares, this land is marginal land along the beach, about 60% of its area has not been used optimally yet. The utilization of the sandy beach land started to be successfully developed after the irrigation network built (severally wells). The utilization of this non-permanent land contains vegetables like onion and chili (Lagiman, 2006 ; Kastono, 2007). The kinds of plant are limited is because cultivating on sand beach was not an easy thing because of physical, biological, and chemical of the land did not support. This is because the sand beach is contained of sands, low nutrition, low water saving ability, and high land

temperature. High wind speed causes high plant evapotranspiration. Daily land temperature is quite high reaching 30-40°C in daytime. The high temperature causes plants dry (Partoyo, 2006).

Reported by Ravi dan Chowdhury (1999), the draught causing colocasia tuber grows slowly even decreases to 10-40%. The draught also causing potato plant roots not adaptive to undeveloped water stress (Opena dan Porter, 1999), inhibited potato tuber forming and tubers starch content decrease (Geigenberger *et al.*, 1999). According to Togari (1990), on field, tuber forming is very affected by its surrounding in the first 20 and 60 days after planting is the period of number of starch grains in the cells of sweet potato tubers forming.

Specific physical and chemical condition of the land needed for draught tolerant variety of plants. Draught adaptable plants tend to produce more stable plant (Pangaribuan *et al.*, 2001). The journals for draught tolerant plant are many reported by (Frederique *et al.*, 2000), for horticulture and corn plant, Maestri (2001), reported that draught tolerant plant will increasing the accumulation of proline where proline acted as compatible osmolit and organic nitrogen reserve on plant used as long as draught occurred. Pangaribuan (2002), reported that the level difference of draught affect the growth of oil palm seedlings and the using of intolerant plant causing water efficiency decreased.

The research's purpose is for digging sweet potato varieties potency in draught pressure. The selection way is to give direct pressure on plant, the result of the method can be used afterwards. Draught tolerant variety is very useful for the sand land people to get an optimal production.

MATERIALS AND METHOD

The research method is held in Agriculture Faculty of UPN VYK field on bamboo house in May to November 2013. Factorial experimentis anexperiment (5x3) consists of 3 replications, arranged in a Split Plot Design. The main plot is consisted of 5 varieties from Balitkabi, Malang collection, they are 1) Beta -1, 2) Beta -2, 3) Papua Solossa, 4) Sari, dan 5) Kidal. Sub plot is consisted of three water stress varieties, they are 1) normal irrigated, 2) not irrigated for 1 week when the plant is 20 hst age (root forming age), and 3) not irrigated for 1 week when the plant is 60 hst age (tuber forming age). The layout is randomized according to group.

The plant material is shoot cuttings length 15-20 cm planted on planting tubs. The media used for the research is the mix of sand and dung 1 : 1. 1/3 dosage of NPK fertilizer 200 kg/ha given when planting and 2/3 of it given when the plant 60 hst age. Irrigation is done due to water stress treatment. Pest and disease control is done using preventing method.

RESULT AND DISCUSSION

On sweet potato case, its dry weight is buried in economically important part of plant which is its root. On field, tuber forming is very affected by its surrounding on the first 20 days after planting. The research showed that there was no interaction between the kind of

variety and draught stress treatment on tuber quantity analysis (Table 1) and tuber weight (Table 2).

.Tabel 1. Average of tuber/plant quantity

Variety	Draught			Average
	C1 (without stress)	C2 (20 HST)	C3 (60 HST)	
V1 (Beta 2)	5,42	4,33	3	4,25 b
V2 (Papua Solosa)	4,67	2,33	2,83	3,28 c
V3 (Sari)	7,22	5,46	4,08	5,59 a
V4 (Beta 1)	3,58	2,83	3,17	3,19 c
V5 (Kidal)	6,67	5,75	5,5	5,97 a
Average	5,51 p	4,14 q	3,72 q	(-)

Note: the average on same letter on the same column (a,b,c) and same line (p,q,r) shows no difference with Duncan test 5%. (-) : no interaction

Table 1 shows that either stress or variety has real effect and varies result on tuber quantity. V3 (Sari) and V4(Beta 1) resulted the most tuber quantity compared to other tuber variety. Unstressed plant (C1) resulted the most tuber compared to Stressed plant (C2 and C3) but not with tuber weight (Table 2). Stressed or unstressed plant resulted the same tuber weight. This proves that sweet potato has good tolerance for draught, as stated by Hahn and Hozyo (1992).

The result on the field was affected by the kind of variety. Sari and kidal variety resulted high tuber quantity and weight (Table 1 and 2). This might be because of photosynthesis rate affected by the shape of the leaves. Smaller sari and kidal variety leaves caused draft, temperature, relative humidity, and light intensity could increase the rate of photosynthesis because these factors are affected CO₂ assimilation.

Table 2. Average of tuber/plant weight (g)

Variety	Draught			Average
	C1 (without stress)	C2 (20 HST)	C3 (60 HST)	
V1 (Beta 2)	430	400	370	400 a
V2 (Papua Solosa)	250	220	490	320 b
V3 (Sari)	410	340	420	390 a
V4 (Beta 1)	260	440	200	300 b
V5 (Kidal)	500	320	400	206,67 c
Average	370 p	344 p	376 p	(-)

Note: the average on same letter on the same column (a,b,c) and same line (p,q,r) shows no difference with Duncan test 5%. (-) : no interaction

The components of sweet potato result are determined the first time by the quantity of tuber roots, then division and cell enlargement determine the size of the tuber, they lead to synthesis of starch grains which determine the density of starch in the cells (Togari, 1990).

Table 3. Average of tuber/plant sugar level (%)

Variety	Draught			Average
	C1 (without stress)	C2 (20 HST)	C3 (60 HST)	
V1 (Beta 2)	17,648	18,841	18,740	18,41 b
V2 (Papua Solosa)	22,518	28,397	28,118	26,34 a
V3 (Sari)	18,575	18,064	19,041	18,56 b
V4 (Beta 1)	18,237	17,724	15,259	17,07 b
V5 (Kidal)	25,510	24,891	24,648	25,02 a
Average	20,498 q	21,583 p	21,161 p	(-)

Note: the average on same letter on the same column (a,b,c) and same line (p,q,r) shows no difference with Duncan test 5%. (-) : no interaction

Draught stress done to sweet potato resulted in tuber starch content increased compared to unstressed plant (Table 3). The same thing happened to tuber level of sugar (Table 4). This was because there's change in one result component under environmental influences often causing adjustment of other components in the plant (Togari 1990). Table 3 and 4 informed that sweet potato varieties showed different responses based on their surroundings. Small leaf variety (Kidal) showed high response on its surrounding. This was because the effect of different genetic character on each variety.

Table 4. Average of tuber/plant sugar level (brix)

Variety	Draught			Average
	C1 (without stress)	C2 (20 HST)	C3 (60 HST)	
V1 (Beta 2)	10,83	13,5	13,33	12,55 a
V2 (Papua Solosa)	11,67	13	11,5	12,06 b
V3 (Sari)	14	13,17	11,5	12,89 a
V4 (Beta 1)	11,67	14,67	11,33	12,55 a
V5 (Kidal)	9,5	14,17	14	12,55 a
Average	11,53 q	13,7 p	12,33 q	(-)

Note: the average on same letter on the same column (a,b,c) and same line (p,q,r) shows no difference with Duncan test 5%. (-) : no interaction

CONCLUSION

Sweet potato variety has character genetically different and does not affected by stress on tuber quantity and weight, sugar level, and tuber sugar. The stress done to 20 hst plant resulted best starch content and tuber sugar. Recommended variety for cultivating on sandy land is Kidal variety.

ACKNOWLEDGEMENT

High appreciation presented to the Directorate General of Higher Education, Ministry of Education that has funded this research.

REFERENCES

- Antarlina, S.S. 1993. *Pengolahan Tepung Ubijalar Menjadi Beberapa Kue*. Laporan Proyek Ubi-ubian. IDRC. 16 p.
- Brocklehurst, P.A., J.P. Moss, and W. Williams. 1998. Effects of Irradiance and Water Supply on Grain Development in Wheat. *Ann. Appl. Biol.* 84. 201-218.
- Darini, M. Th. dan Y. Sunaryo. 2002. Tanggapan Tanaman Bawang Varietas Lokal pada Kondisi Cekaman Air dan Macam Pupuk Kandang di Lahan Pasir Pantai. *Agrivet* 6 (2) : 119 - 128
- Frederique,R., Pascale, G., Dominique de Vienne, and Michel, Z. 2000. Protein change in Respon to Progressive Water Deficit in Maize. *Plant physiol.* 117 : 1253-1263
- Geigenberger, P., B. Muller- Robert, and M. Stitt. 1999. Contribution of Adenosine 5-diphosphoglucose pyrophosphorylase to The control of Starch synthesis id Decreased by water stress in growing potato tubers. *Planta* 209 : 338-345
- Kastono, D., D. Shiddieq, Tohari, E. Sulistyarningsih, dan Saparso. 2007. Pengaruh Pemberian Lapis Kedap Bentonit, Frekuensi dan Volume Pengairan terhadap Pertumbuhan dan Hasil Bawang Merah di Lahan Pasir Pantai. *Prosiding Seminar Nasional HITI*. Fakultas Pertanian UPN. Yogyakarta. 2007.
- Lagiman. 2006. Pertumbuhan dan Hasil Tiga Varietas Bawang Merah di Lahan Pantai dengan Variasi Pupuk Kandang dan Bahan Berlempung. *Agrivet.Vol. 10. NO. 2 Desember 2006 : 132-141*
- Maestri, B., F.M. Da Matta, A.J. Regazzi, and Barros. 2001. Accumulation of Proline and Quartenary Ammonium Compounds in Mature Leaves of Water Stressed Coffee Palnts. *Hort Science.* 70(2) : 229-233.
- Opena, G.B. and G.A. Porter. 1999. Soil management and Supplemental irrigation effect on Potato : Root Growth. *Agron. J.* 91: 43-431.
- Pangaribuan, Y. 2001. Studi Karakter Morfologi Tanaman Kelapa Sawit (*Elaeis guineensis* Jacg.) di Pembibitan terhadap Cekaman Kekeringan. Makalah Seminar Pascasarjana IPB Bogor. (tidak dipublikasikan)
- Partoyo. 2006. Perkembangan Profil Tanah Di Lahan Pertanian Gumuk Pasir Pantai Samas Yogyakarta. *Jurnal Tanah dan Air. Vol. 7 No. 1. Juni 2006.*
- Rahayuningsih, St. A, Y. Widodo, dan M. Yusuf. 2004. Keragaman Bibit Penjenis Varietas Unggul Ubijalar Pada Berbagai Tingkat Pemupukan dalam Teknologi Inovatif Agribisnis Kacang-kacangan dan Umbi-umbian Untuk Mendukung Ketahanan Pangan.Puslitbang. Tan. Pangan.

Ravi, V. and S.R. Chowdhury. 1999. Growth and Yield Respone of Colocasia Accessions to Drought Stress. Science Publishers Inc, America.

Togari, Y. 1990. Study of the tuberous root formation of sweet potato. *Nat. Agric. Expl. Stition. Tokyo. Japan. Bull.*

THE IDENTIFICATION OF USEFUL VEGETATIONS ON DIFFERENT AGES OF OIL PALM (*Elaeis guineensis* Jack)

Ety Rosa Setyawati

STIPER Agriculture University, Jln Nangka II Maguwoharjo Depok Sleman,
Yogyakarta Indonesia

setyawatietyrosa@yahoo.com

ABSTRACT

The goal of this study was to know how to manage the useful vegetations in oil palm plantation in the composition on the different ages and identification of legume cover crops (LCC). The research was using descriptive method, by observation variety vegetations grew under oil palms and vegetation analyzes. The study showed that varieties useful vegetations as an organism where parasite ate and lived for parasitoid and predator eat leaf caterpillars that ate oil palm leaves. These were :*Turnera subulata*, *Urena lobata*, *Cassia tora*, *Euphorbia heterophylla*, *Antogonon leptopus*, *Elephantopus tomentosus*, *Ageratum conyzoides*, *Celosia argentea*, *Stachytarpentha indica* and *Diplazium asperum*. The varieties of legume cover crops that lived on the plantation were *Nephrolepis bisserata*, *Pueraria javanica*, *Calopogonium mucunoides*, *Pueraria phaseodoloides*, *Mucuna bracteata* and *Ipomoea margarita*.

Keywords: LCC, Oil Palm, Vegetation

INTRODUCTION

Oil palm has a superior plant characters than other vegetable oil plants. It oil productivity is higher, and stronger in different weather changes and has a lot of usages both in edible and un-edible matter than others. The three characters that are mention above can guarantee on its price, supply continuity and various usages.

The goal that are hoped by oil palm plantation management are the everlasting and sustainable plantation, where every plantation manager must keep everlasting that match with the goal. The real action that can be done is using organic matter from the nature for example the use of vegetations that are useful on oil palm plantation.

Useful vegetations can be separated on two groups. The first are Leguminous Cover Crops (LCC), and the second are crops as control concerning agents. LCC is useful for cover crops, N fixation from air, increasing soil fertility and decreasing weed. The second group are crops that useful for sustaining parasitoid and predator, control agents fire caterpillar and pouch caterpillar.

Commonly, the exist of various useful vegetations in the field can only be seen visually, but exact the composition in the oil palm plantation are unknown. So, the study of useful vegetations on different ages of oil palm is needed for controlling and managing the useful vegetations.

The aim of the study are:

1. To know the management of useful vegetations in oil palm plantation.
2. To know the composition of useful vegetation on various ages of oil palm.

The advantage of this study is to provide information for the plantation manager about the useful vegetations that can be developed in the farm.

MATERIAL AND METHODS

The research was conducted on Letawa Firm Farm in afdeling Golf, Makmur Jaya village, Tickle, North Mamuju, West Selebes Province on July 2012.

Materials: scissors, knife, saw, camera, hammer, nail, white paint, metre, wood 1.5 x 1.5 m, yellow cloth, oil palm plant blocks were the age of 1, 15, 18, and 20 years old.

Methods of the study was by observing visually and taking a note about useful vegetations, sampling was done by dividing one block (\pm 40 ha) into 112 sectors.

RESULT AND DISCUSSION

Table 1. Composition of useful vegetations on different ages of oil palm

A. Wide leaf vegetations					
No	Species	1 year	15 years	18 years	20 years
1	<i>Turnera subulata</i>	-	3 %	2 %	1 %
2.	<i>Urena lobata</i>	-	1 %	-	3 %
3.	<i>Casia tora</i>	-	-	-	4 %
4.	<i>Euphorbia heterophylla</i>	5 %	2 %	-	-
5.	<i>Antigonon leptopus</i>	-	5 %	3 %	1 %
6.	<i>Elephantopus tomentosus</i>	-	2 %	-	1 %
7.	<i>Ageratum conyzoides</i>	-	8 %	12 %	2 %
8.	<i>Celosia argentea</i>	4 %	1 %	-	-
9.	<i>Stachytarpenantha indica</i>	5 %	-	-	12%
B. Legume					
No	Species	1 year	15 years	18 years	20 years
1.	<i>Pueraria javanica</i>	4 %	3 %	32 %	1 %
2.	<i>Calopogonium mucunoides</i>	-	2 %	8 %	4 %
3.	<i>Pueraria phaseoloides</i>	-	-	4 %	-
4.	<i>Mucuna bracteata</i>	78 %	2 %	5 %	-
5.	<i>Ipomoea margarita</i>	-	1 %	1 %	-
C. Conifer					
No	Species	1 year	15 years	18 years	20 years
1.	<i>Nephrolepis bisserata</i>	3 %	52 %	1 %	33 %
2.	<i>Diplazium asperum</i>	1 %	18 %	33 %	38 %
Total		100 %	100 %	100 %	100 %

1. *Turnera subulata*

Turnera subulata was found in all ages oil palm plants except in 1 year old. This plant provides food for imago of parasitoid and predator caterpillar which sucked nectar and ekstrafloral gland, especially parasitoid *Brachymeria lasus*, *Spinaria spinator* and *Hyper predator* (Prawirosukarto *et al*, 2005)



Figure 1. *Turnera subulata*

2. *Urena lobata*

Urena lobata was found on 15 and 20 years old oil palm plants. In the contrary these vegetations were not found on 1 and 18 years old oil palm plants. These vegetations preferred open space and predator insect of fire caterpillar was almost could not be found. It took food on ekstrafloral gland in the flower of *Urena lobata*. In the humid and shading area can be seen on the existence of parasitoid of fire caterpillar *Chloryptus purpuratus* (Hendarjanti, 2005).



Figure 2. Parasitoid insect *Brachymeria lasus*



Figure 3. *Urena lobata*

1. *Cassia tora*

This useful vegetations, commonly grow naturally in the edge of block. This vegetation was only found in 20 years old of oil palm plant. The advantage of this vegetation was providing food for imago of parasitoid of caterpillar that eat leaf of oil palm, *Brachymeria lasus* and *Dolichogeina sp.* (Agus *et al*, 2007).



Figure 4. *Cassia tora*

2. *Euphorbia heterophylla*

Euphorbia heterophylla grew in 1 and 15 years old of oil palm plant. In other ages this vegetations were not found. This vegetation was easily adapted in peat moss soil and mostly grew in the edge, usually grew naturally or was grown by human. The shape was easily known, the root was steep ravine (upside down) and the stem upside with a lot of branches. The flowers was green, and natural enemy of

caterpillar that eat leaf oil palm (*Hyper predator*) and parasitoid *Spinaria spinator* was found in this part. The insect came in the morning and evening.



Figure 5. *Euphorbia heterophylla*



Figure 6. Insect parasitoid *Spinaria spinator*



Figure 7. Insect predator *Hyper predator*

3. *Antigonon leptopus*

Antigonon leptopus was found in all oil palm ages except in one year old plant block. This vegetation relatively difficult to be found because it could not grow

naturally in the block. The advantage of this vegetation was a source food of predator of caterpillar that eat of leaf of oil palm plant (*Sycanus sp.* and *Hyper predator*) (Hendarjanti, 2005).



Figure 8. *Antigonon leptopus*

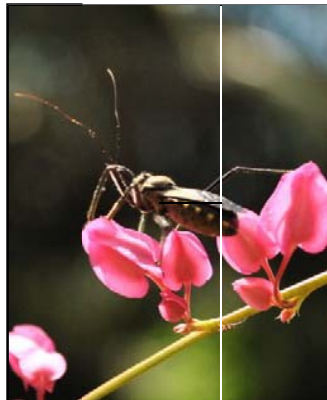

Figure 9. Insect predator *Sycanus sp.*

4. *Elephantopus tomentosus*

This vegetation was parasites and as a host of fire caterpillar. *Elephantopus tomentosus* was found only in 15 and 20 year old oil palm blocks. This vegetation provides food for imago parasitoid of fire caterpillar (*Chaetexorista javana*) (Anonim, 2005).



Figure 10. *Elephantopus tomentosus*

5. *Ageratum conyzoides*

This vegetation was eaten by parasitoid *Chaetexorista javana*. *Ageratum conyzoides* was found on blocks 15, 18 and 20 year old of oil palms. *Ageratum conyzoides* grew in colony in humid and shaded soil. In this habitat usually *Ageratum conyzoides* upsided stem was longer, but in the hilly habitat and open light the growing was shorter and dwarf. Eventhough the character of this vegetation is as biological controller of caterpillar that eat leaf of oil palm, this vegetation was handled as a weed.



Figure 11. *Ageratum conyzoides*

6. *Celosia argentea*

This vegetation was useful for parasitoid and predator (*Eucanthecona furcellata* and *Chaetoxotista javana*) (Hendarjanti, 2005). This vegetation was found in 1 and 15 year old of oil palm. This species was highly taken care by plantation management because of its roll for parasitoid and predator.



Figure 12. *Celosia argentea*

7. *Stachytarpenantha indica*

This vegetation was found a lot in oil palm 1 and 20 year old. Usually on the border of a block. The height was about 20-90 cm. *Stachytarpenantha indica* was taken care by manager to help eternally predator and parasitoid of fire and pouch caterpillar for example *Brachymeria lasus*.

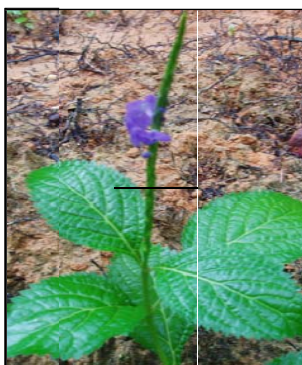

Figure 13. *Stachytarpenantha indica*

8. *Diplazium asperum*

Diplazium asperum could adapt in many vegetation. This vegetation could be found on all of research land This plant parasite ate and lived for larva bee *Neosstromboceros lucthi* where this bee was food for fire caterpillar predator, beetle *Eucanthecona furcellata* in oil palm plantation (Prawirosukarto *et al*, 2005).

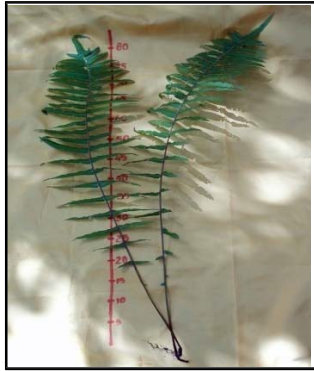

Figure 14. *Diplazium asperum*

CONCLUSIONS

1. The useful vegetations for parasitoid and predator caterpillars that ate oil palm leaves were *Turnera subulata*, *Urena lobata*, *Cassia tora*, *Euphorbia heterophylla*, *Antigonon leptopus*, *Elephantopus tomentosus*, *Ageratum conyzoides*, *Celosia argentea*, *Stachytarpentha indica* and *Diplazium asperum*.
2. Insects parasitoid of fire and pouch caterpillar were *Brachymeria lasus*, *Chloryptus purpuratus*, *Dolichogenia sp.* *Spinaria spinator* and *Chaetexorista javana*.

REFERENCES

- Anonim. 2010. Pengendalian Kimiawi dan Hayati Ulat Api. Klinik Sawit. <http://kliniksawit.com/ulatapi>. accessed January 16 th 2012.
- Hendarjanti, H.. 2005. Evaluasi Tanaman *Turnera subulata*, *Celosia argentea*, *Cassia tora* dan *Euphorbia heterophylla* sebagai Tanaman Bermanfaat Untuk Pelestarian Parasitoid dan Predator UPDKS. Astra Agro Lestari, Riau.
- Prawirosukarto, S. Syamsudin dan Darmosarkoro, W. 2005. Tanaman Penutup Tanah dan Gulma Pada Kebun Kelapa Sawit (Buku II). Pusat Penelitian Kelapa Sawit (PPKS). Medan.
- Susanto, A. Ps Sudharto dan Fahrída Y. 2007. Konservasi dan Perbanyakán Musuh Alami Hama, Penyakit dan Gulma Kelapa Sawit. Pusat Penelitian Kelapa Sawit (PPKS). Medan.

VARIATION ON COLCHICINE'S CONCENTRATIONS AND GERMINATION PHASES TO PRODUCE POLYPLOID TOMATO PLANT

Rati Riyati, Nurngaini, Basuki.

Study Programme of Agrotechnology, Agriculture Faculty,
University of Pembangunan Nasional "Veteran" Yogyakarta

Email: rati_riyati@yahoo.co.uk

ABSTRACT

Tomatoes (*Lycopersicon esculentum* Mill.) is an essential type of vegetable which is recommended to be consumed to maintain body's stamina as it contains of the body needs, i.e. pro vitamin A, vitamin C, lycopene and minerals. This research aims to obtain seedless polyploid tomato fruits. Field experiments was conducted by field using polybags consisting of two factors and three replicats arranged in complete randomized block design (CRBD). The first factor was germination phase pre plumula formation phase and post plumula formation phase. The second factor was colchisins concentration 0 ppm,1000 ppm, 2000 ppm, 3000 ppm, and 4000 ppm. Ten combinations of treatments a were obtaination requires ten plant. Observation was made on growth, yield and the quality of the plant. To examine the anatomical properties, microscopic observation was conducted on the stomata and on the cross-section of the leaf. The variance of data was then analyzed at 5% significance level. To find out the difference between the treatments, Duncan's Multiple Range Test and Least Significance Difference (LSD) were done in 5% significance level. The result showed that 1). Polyploidy occurred on the treatment combination of colchicins concentration of 4000 ppm and post plumulaformation, 2) Sterile fruit was produced, and 3) Some characters were not different significantly, however vitamin A level and sugar level showed a significantly difference.

Keywords: Germination Phase, colchicines concentration, polyploid tomato plants

INTRODUCTION

Tomato (*Lycopersicon esculentum* Mill.) is an essential vegetable recommended to maintain body's stamina due to its pro vitamin A and C, Lycopene and mineral contents needed by human body (Wiryanto,2004). In Indonesia, tomato is used as a food seasoning compliment and raw materials for tomato sauce and cosmetic industry. The increasing demand of tomato for recent years has lit a bright prospect for the cultivation of this vegetable. An example of the development is the invention of seedless tomato. Technically, to gain a superior variety of seedless tomato which produce high yields, a polyploidy symptom which is combined with hybridization technology can be applied (Basuki, 2010). Polyploidy is a condition when a material has two or more sets of basic chromosomes or

genome. The characteristic of polyploidy plants is that its physical appearance looks more sturdy marked by bigger roots, rods, leaves, fruit flowers, cells, nucleuses and stomata. In some species, the petiole and the leaves look bigger than normal diploid plants. Moreover, it is also marked by leaves' colour which is also darker and bigger petal size (Suryo, 1995). In regards with agronomy and economy, polyploidy plants are favourable for both producers and consumers.

A polyploidy symptom can be deliberately produced through a treatment which uses chemical substances such as colchicine (Basuki, 2010). Colchicine is an alkaloid compound originated from pansy tuber of Liliaceae family which is known as grasses growing in autumn (*Colchicum autumnale* L.) Colchicine can cause efflorescent to plants and induce bigger tubers. However, its effects are unpredictable even though polyploidy often results escalation of plant's phenotypic property. (Głowacka et al., 2009).

On certain plants induced with polyploidy, colchicine can be applied in some particular ways. On each treatment, cell cleavage on the growing point of its meristem should be affected by the treatment. Should the treatment given is inappropriate, then only certain parts of tissues are affected and polyploidy does not occur in all part of the plant. Seed and seedlings can be soaked on colchicine solution or colchicine can be applied only at the growing points of plant (Liu et al., 2009). Working mechanism of colchicine is trough binding dimer β -tubulin and inhibits microtubule assembly. However, colchicine does not inhibit the function of assembled microtubule. Therefore, chromosome doubling occurs as an effect of microtubule's failure to pull chromosome towards the pole (Burns, 1992). Hence, in this case, colchicine has a function to separate spindle thread.

Colchicine is a chemical stuff which is easily dissolved in water and its effects are immediately known and hence it is easily applied and effective to produce polyploidy plants (Suryo, 1995). Based on a research conducted by Nurgaini and Rati (2011), an immersion treatment of tomato varieties called Ratna and Kaliurang in colchicine solvents for 24 hours with concentrations of 500 ppm, 1000 ppm, 1500 ppm, and 2000 ppm respectively has not shown any polyploidy symptoms. Therefore, it is necessary to conduct a germination experiment. It is expected that germinated seeds are able to absorb colchicine in more optimal and hence it can produce a polyploidy result.

Based on those arguments, it is necessary to conduct a research about "Various Colchicine Concentrations and Germination Phases to Produce Polyploidy Tomato Plants". The aims of this research are: 1). Producing polyploidy tomato plants, 2). Comparing the size of plant organs between polyploidy tomatoes and diploid (normal) tomatoes.

MATERIALS AND METHODS

The research was conducted through a field experiment using two factorial polybags with three repetitions in accordance with Randomized Complete Block Design (Gomez dan Gomez, 1995). As the main factor is the germination phases (after the seeds are immersed in water for 24 hours before they are dissolved in colchicine solvent) and second factor is the colchicine concentrations. The first factor (germination phases) consists of: F1 = prior plumulae period and F2: post plumula period. The second factor is colchicine concentration

which comprises of five levels: K1 = 0 ppm, K2 = 1000 ppm, K3 = 2000 ppm, K4 = 3000 ppm and K5 = 4000 ppm. Combining those two factors, there are ten combinations of treatment, each of them consists of three repetitions. Each combination of treatment includes as many as ten polybags which make 300 polybags in total.

After tomato seeds are immersed for 24 hours in colchicine solvents, they are then germinated in small polybags. Having germinated for two weeks, the seeds are then transferred to bigger polybags. To control pests and diseases, a Curacron is used mechanically with appropriate dosages.

Parameters measured comprises of: 1) Plant Heights (cm), 2) Number of Petioles, 3) Rod Diameters, 4) Length and Width of Stomata, 5) Flower Sizes, 6) Number of Fruits on each plant, 7) Fruit Diameters, 8) Plant Weights, 9) Vitamin C contents (mg), 10) Vitamin A contents (mg), and 11) Total Glucose Level. The field research results are then examined and analyzed of its variance at 5% significance level. To find out the differences among treatments, Duncan's Multiple Range Test is then applied at 5% significance level. At the same time, to find out the differences between the average of treatments and the control, Orthogonal Contrast is applied (Gomez dan Gomez, 1995).

RESULTS AND DISCUSSION

A. T-test on several Characters of Tomato

Based on visual observation in the treatment combination between post plumulae and colchicine concentration of 4000ppm (F2K5) a polyploidy symptom occurs. The analysis shows that both polyploidy plants and polyploidy fruits have stomata length and width is significantly bigger than normal diploid plants and fruits (F2K1: post plumulae period without colchicine immersion).

Chemical composition of polyploidy tomatoes which is total glucose level, vitamin A level, vitamin C level are not significantly different with diploid (Table 1).

Table 1. T-test on some characteristics of polyploidy tomato and diploid tomato

Parameter	Colchicine Treatment		t count
	F2K5 (polyploidy)	F2KI (diploid)	
Length of Leaf Stomata (μm)	31,6667	24,5200	n
Width of Leaf Stomata (μm)	19,2433	14,8867	n
Total Glucose level (%)	5,9363	6,0860	tn
Vitamin A level ($\mu\text{g}/100\text{ g}$)	6,2982	6,1530	tn
Vitamin C level ($\text{mg}/100\text{ g}$)	42,4149	42,0544	tn
Fruit	Seedless	Seed	-
Leaf morphology	Sturdier	Normal	-

Note: n =significantly different at 5 %

This relates with the seed formation in which the fruit flesh which is closer to the seed has higher glucose level, however since the seed is never formed, the glucose level is lower. The unformed seed is due to the incompatibility. The successfulness of seed formation is initiated by pollination which then is followed by fertilization. Fruits formed turn out to be sterile and do not produce any seeds. The cause of this is still unknown. However some possibilities might cause this phenomenon for instance the failure of germination of the tube pollen is caused by dried stigmas. Another possibility is that the germination has already occurred but the tube pollen fails to converge with ovum as the energy is drained on the way to egg nucleus. Aside from that, another possibility is an incompatibility between pollen core and egg nucleus resulting the failure of germination process and hence no seeds are formed. This incompatibility is caused by the gen contained by anther tissues obscure the growth of stamen caused by the immunological reaction between protein located in pollens and anthers (Suryo, 95). The leaf of polyploidy plants shows a more sturdy appearance compared with that of diploid ones. The length of stomata found in polyploidy tomato is 29.27% longer, while its width is 29.26% wider than the normal tomato. With larger stomata, the photosynthesis process could be well implemented in better way and hence will yield more photosynthates that form sturdier roots.

B. Growth, Yield and Fruit Quality

1. Growth, Yield and Microscopic Observation of Tomato Plant

The average of growth, yield and microscopic tomato plants are served in table 2.

Table 2. Averages of Growth, Yield and Microscopic Observation of Tomato Plant

Parameter	Colchicine concentration (ppm)					Germination Phases		Interaction
	K1 (0)	K2 (1000)	K3 (2000)	K4 (3000)	K5 (4000)	F1 (prior plumulae)	F2 (post plumulae)	
Plant Height (cm)	40,66 a	39,77a	34,83a	42,66a	39,27a	39,22p	39,66p	(-)
Number of Petiole	12,66 a	13,22 a	14,11 a	14,44 a	11,78 a	11,64 p	14,84 p	(-)
Rod Diameter (cm)	0,74 a	0,80 a	0,88 a	0,86 a	0,88 a	0,82 p	0,85 p	(-)
Calyx Diameter (mm)	19,00 a	18,55a	18,55a	19,00a	19,50a	18,19p	19,75p	(-)
Corolla Diameter (mm)	26,61a	27,61a	25,39a	24,89a	25,61a	25,68p	25,95p	(-)
Fruit Diameter (mm)	48,70a	47,05a	39,54a	43,29a	41,35a	44,77p	43,20p	(-)
Numbers of Fruit	40,05a	50,50a	35,33a	37,16a	37,94a	39,19p	40,48p	(-)
Fruit Weight (kg)	2,03a	1,93a	1,66a	1,72a	1,42a	1,69p	1,81p	(-)
Stomata Width (μ m)	15,40a	15,85a	16,41a	16,19a	16,78a	15,42p	16,73p	(-)
Stomata Length (μ m)	24,85a	28,32a	26,74a	26,76a	30,33a	27,14p	27,66p	(-)

Note: Figures followed with the same alphabet show that there is no significant difference on Duncan Multiple Range Test in 5% significance level. Symbol(-) shows there is no interaction.

Table 2 shows that growth parameters (plant height, numbers of petiole, rod diameter, calyx diameter, corolla diameter); yield parameters (fruit diameter, numbers of fruit and fruit weight); and microscopic observation (stomata width, stomata length) all show that there is no significant difference for both combination of treatments (colchicine concentration and

germination phases). Examining the table as a whole, there is no significant difference at a glance, however among combination of treatments there are some plants showing polyploidy symptom. This information is used to compare with diploid plants as shown in the Table 1.

2. Vitamin C Level

The result of Duncan Test on Vitamin C parameters is presented in

The analysis of variance shows that there is an interaction between colchicine concentration and germination phases to the vitamin C of tomato fruit, even though in average there is no significant difference.

Table 3. Vitamin C level of Tomato Fruit (mg/100g) at various colchicine concentrations and germination phases

Colchicine Concentration	Germination Phases		Average
	F1(prior plumulae)	F2(post plumulae)	
K1 (0 ppm)	42.0834 a	42.0544 a	42.0689
K2 (1000 ppm)	42.4875 a	43.4232 a	42.9553
K3 (2000 ppm)	43.4661 a	43.4140 a	43.4400
K4 (3000 ppm)	44.3043 a	42.0950 a	43.1996
K5 (4000 ppm)	43.9393 a	42.4149 a	43.1771
Average	43.25612	42.6803	(+)

Note: Figures followed with the same alphabet shows there is no significant difference on Duncan test at 5% significance level. Symbol (+) shows that there is interactions.

3. Vitamin A Level

The result of Duncan Test on Vitamin C parameters is presented in Table 4.

Table4. Vitamin A level of Tomato Fruit ($\mu\text{g}/100\text{ mg}$) at various colchicine concentrations and germination phases.

Colchicine Concentration	Germination Phases		Average
	F1(prior plumulae)	F2(post plumulae)	
K1 (0 ppm)	6.0456 g	6.1530 defg	6.0993
K2 (1000 ppm)	6.1900 bcdef	6.2104bcde	6.2002
K3 (2000 ppm)	6.3058ab	6.0372 g	6.1715
K4 (3000 ppm)	6.2565abcd	6.0835fg	6.1700
K5 (4000 ppm)	6.3608 a	6.2982abc	6.3295
Average	6.23174	6.15646	(+)

Note: Figures followed with the same alphabet shows there is no significant difference on Duncan test at 5% significance level. Symbol (+) shows that there is interactions.

The table shows that there is an interaction between colchicine concentration and germination phases to the vitamin C of tomato fruit. A treatment of colchicine concentration of 4000 ppm applied prior plumulae period yields highest vitamin A, although it results no significant difference on colchicine concentration of 2000 ppm and 3000 ppm which was applied prior plumulae period. It also shows the same result when a treatment of colchicine concentration of 4000 ppm is applied post plumulae period.

4. Level of Glucose

The result of Duncan Test on Level of Glucose is available in Table 5.

Table 5. Glucose Level (%) of Tomato Fruit at various colchicine concentrations and germination phases.

Colchicine Concentration	Germination Phases		Average
	F1(prior plumulae)	F2(post plumulae)	
K1 (0 ppm)	5.6104 cd	6.0860 a	5.8482
K2 (1000 ppm)	5.3994 d	5.3873 d	5.3933
K3 (2000 ppm)	6.0436ab	5.6117 cd	5.8276
K4 (3000 ppm)	5.6378 cd	5.6031 cd	5.6204
K5 (4000 ppm)	5.5453 d	5.9363abc	5.7408
Average	5.6473	5.7248	(+)

Note: Figures followed with the same alphabet shows there is no significant difference on Duncan test at 5% significance level. Symbol (+) shows that there is interactions

Table 5 above mentions that there are interactions between colchicine concentration and germination phases. The highest level of glucose is found on the treatment of no colchicine immersion on the period of post plumulae however there is no significant difference on the treatment of 2000 ppm of colchicine concentration applied prior plumulae period and the treatment of 4000 ppm of colchicine concentration applied post plumulae period.

CONCLUSION

Limited to the research and discussion, some statements can be concluded as follows:

1. Colchicine 4000 ppm and post-plumulae period (F2K5) shows polyploidy symptom.
2. Steril fruit was produced
3. Some characters were not different significantly, however vitamin A level and sugar level showed a significantly difference.

REFERENCES

- Basuki, 2010. Teknologi Hibridisasi dan Poliploidi Menjawab tantangan pengentasan kelaparan. Prosiding Seminar Nasional. Pertanian Indonesia Menuju Millenium Goals (MDGs) 2015. DI Yogyakarta. 12 juni 2010. Kerjasama UMY dengan PERHEPI.
- Gomez K.A. and A.A. Gomez. 1995. Prosedur Statistik Untuk Penelitian Pertanian. Terjemahan E. Syamsudindan J.S. Baharsjah. UI-PRESS. Jakarta.
- Nurngaini dan R. Riyati, 2011. Berbagai Konsentrasi Kolkhisin untuk Menghasilkan Tanaman Tomat Poliploid. Laporan Hasil Penelitian. Tidak Publikasi. LPPM-UPNVY.
- Suryo. 1995. Sitogenetika. Gadjah Mada University Press. Yogyakarta.
- Wiryanta, 2004. Bertanam Tomat. Agro Media Pustaka. Jakarta.

UTILIZATION OF CRITICAL LAND FOR TUBER CROPS CULTIVATION AS RAW MATERIALS OF AGRO-INDUSTRY

Bargumono and Tuti Setyaningrum *

Department of Agrotechnology, Faculty of Agriculture, Universitas Pembangunan Nasional "Veteran" Yogyakarta, Indonesia

Jl. SWK 104 Lingkar Utara Condongcatur Yogyakarta

*Email: *bargumonogumono@yahoo.co.id*

ABSTRACT

Considering that the accumulation of degraded land in Indonesia is fairly extensive, according to the survey Indonesian Institute of Sciences (LIPI), serious action is need to handle the critical areas for agricultural business to fulfill the national food necessity. Efforts of that, especially rice, has been done by the government. As an alternative foodstuff, tubers are needed to be developed. Utilization of degraded land for cultivation of tubers has also been performed by many local farmers, but the scientific research must to be done so that the increase in productivity can be measured in to detail. This case study objective is to find a solution to increase food production, especially tubers in critical areas, as raw materials to support the national industry. Provision of tubers as raw materials for national industry today is still not able to fulfill the necessity in terms of quantity, quality and continuity. For that we need a serious handling of tubers cultivation for industrial raw materials. Various ways of tuber crops cultivation in critical area has been done, but the yields are still not accordance to the expectations. Meanwhile, every year the area of fertile land become less and less. Besides being used for agricultural business, the function of land changed for residential purposes is increasing. Utilization of degraded land for tuber crops is expected to fulfill the necessity of industrial raw materials.

Keywords: critical land, tubers, national food

INTRODUCTION

The human requirement of agricultural production as food material (primarily) and renewable biological energy, food, cosmetics and pharmacy industrial resources is growing.

Economic and monetary crisis in 1998 gave a valuable lesson. At the moment that manufacture and finances industrial was felt down, agriculture could be survive, and also could be the biggest manpower absorber (Yuwono, 2011). Agriculture have great contribution in economic development process (Widodo, 2011). The success of agricultural production can't be separated from land readiness.

Indonesian agricultural land as wide as 7.75 millions hectares (Suhendra, 2013), not all is fertile land. About 90 millions hectares according to the survey of LIPI is unfertile land. In the meantime, the width of fertile land is decreasing every year. Beside the used for agricultural business, every year transfer of function for housing requirement is increasing.

DISCUSSION:

Table 1. Situation of Perilous Area by Regency/City in Jawa Tengah 2010 (ha)

Regency/City	Most Perilous	Perilous	Perilous Rath	Perilous Potention	Not Perilous	Total
(1)	(2)	(3)	(4)	(5)	(6)	(7)
01. Kab. Cilacap	-
02. Kab. Banyumas	-
03. Kab. Purbalingga	437,88	1.586,83	9.999,73	2 6.695,88	2 1.311,80	60.032,12
04. Kab. Banjarnegara	546,69	10.667,02	26.686,88	3 5.063,02	1 2.332,29	85.295,90
05. Kab. Kebumen	955,91	5.496,20	18.903,48	4 7.438,97	3 9.765,25	112.559,81
06. Kab. Purworejo	243,08	8.682,67	27.904,77	2 9.571,10	31.641,53	98.043,15
07. Kab. Wonosobo	122,51	11.781,08	14.987,43	3 4.162,71	1 3.324,61	74.378,34
08. Kab. Magelang	-	7.372,58	24.211,25	4 1.820,93	2 9.630,16	103.034,92
09. Kab. Boyolali	13,91	1.566,19	28.083,36	4 5.594,99	7 3.171,90	148.430,35
10. Kab. Klaten	-	36,11	19.307,76	3 5.155,77	1 0.045,38	64.545,02
11. Kab. Sukoharjo	-	989,47	15.892,08	1 3.910,95	1 8.189,38	48.981,88
12. Kab. Wonogiri	-	19.992,77	78.194,10	3 6.159,81	2 3.210,84	157.557,52
13. Kab. Karanganyar	-	-	3.563,71	2 6.108,95	4 1.943,82	71.616,48
14. Kab. Sragen	-	815,36	7.221,24	1 6.891,87	5 7.240,05	82.168,52
15. Kab. Grobogan	75,14	1.069,54	5.605,29	1 1.670,01	1 15.493,33	133.913,31
16. Kab. Blora	3,22	928,64	8.915,49	1 8.444,42	110.218,09	138.509,86
17. Kab. Rembang	326,86	1.885,88	7.747,19	5.841,67	6 9.225,74	85.027,34
18. Kab. Pati	1.911,22	4.843,49	7.742,20	2 6.336,92	9 4.668,27	135.502,10
19. Kab. Kudus	-	698,35	4.619,62	4.039,78	3 2.046,77	41.404,52
20. Kab. Jepara	8,37	1.074,49	6.149,48	2 1.737,69	5 8.104,72	87.074,75
21. Kab. Demak	-	-	1 52,73	9 45,05	9 5.357,12	96.454,90
22. Kab. Semarang	30,82	8.593,02	16.132,77	1 9.882,70	4 9.229,53	93.868,84
23. Kab. Temanggung	-	2.853,56	20.308,11	1 3.931,52	1 9.300,79	56.393,98
24. Kab. Kendal	59,75	1.890,69	3.472,10	1 7.129,89	6 0.708,90	83.261,33
25. Kab. Batang	123,50	160,44	3.105,77	9.375,36	5 4.433,72	67.198,79
26. Kab. Pekalongan	733,02	2.317,67	4.184,89	8.329,19	4 5.691,23	61.256,00
27. Kab. Pemalang	-	1.851,65	8.642,67	1 6.100,68	5 4.896,41	81.491,41
28. Kab. Tegal	-	270,15	2.229,20	8.300,87	6 2.794,96	73.595,18
29. Kab. Brebes	103,04	597,38	5.905,84	1 4.331,34	1 07.920,00	128.857,60
30. Kota Magelang	-	-	-	1.327,70	2 82,86	1.610,56
31. Kota Surakarta	-	-	47,81	1 41,98	4 522,32	4.712,11
32. Kota Salatiga	-	26,95	2 52,22	4 56,05	4 570,85	5.306,07
33. Kota Semarang	-	197,45	613,29	8.890,44	2 7.225,94	36.927,12
34. Kota Pekalongan	-	-	14,17	3 1,75	4 632,41	4.678,33
35. Kota Tegal	-	-	5,44	3 6,78	3 693,10	3.735,32
Total 2010	5.694,92	98.245,63	380.802,07	595.856,74	1.446.824,07	2.527.423,43
2009	6.419,05	75.130,74	252.403,19	489.215,49	1.311.727,01	2.134.895,48
2008	18.462,19	140.103,91	418.982,97	579.044,81	1.519.166,87	2.675.760,75
2007	14.641,37	115.564,07	442.225,93	697.036,53	589.762,73	1.859.230,63

Source : "BPDAS Pemali Jratun Semarang, BPDAS Serayu Opak Progo Yogya, BPDAS Solo
 Fertile land or potential land for agriculture has many features: the level of fertility is high, has a good physical characteristic, and has no erosion experienced yet. Meanwhile, unfertile land or critical land is a land that has fertility decline experienced or a land in process of physical, chemical, and biological fertility decreasing (Bahri,

2009). The features of critical land for agriculture are not fertile and lack of organic manure.

Since accumulation of critical land in Indonesia is quite extensive (as showed at table 1), a serious action in handling the critical land is needed for agricultural business to support the fulfillment of national food necessity. Many efforts to fulfill the national food necessity such as rice have been done by the government. As an alternative food material, tubers plant is need to be developed.

Tubers plant is phyto material which is obtained from the soil land such as cassava, sweet potato, potato, and so on. Commonly, tubers forms material of carbohydrate source especially starch. Beside as an alternative food material, tubers also have a potency to be developed as industrial basic substance in addition to many other commodities.

The purpose of these case study is looking for a solution, how to increase food production especially tubers as industrial basic substance at critical land, to fulfill national industrial necessity.

The act of supplying tubers as national industrial basic substances, nowadays is still can't fulfilled completely in quantity, quality, and continuity. For that, a serious handling in tubers cultivation as a basic substance industry is necessity.

Utilization of critical lands for tubers cultivation have been done in great numbers by local farmers, but scientific and measured researches have to be done more so the raising of productivity per area can be known into detail and come near to the correctness, especially tubers cultivation that done in critical land as alternative food plant.

CONCLUSION:

Many ways in tubers plant cultivation in critical land have been done, but the yield has not in accordance yet with the expectation. Hope that utilization of critical land with tubers plant will fulfill the necessity of basic substance industry.

REFERENCES:

- Bahri, Len. 2009. Penanggulangan Lahan Kritis Melalui Teknologi Konservasi. Balai Pengkajian Teknologi Pertanian, Solok, Sumatera Barat, Indonesia.e-mail: sumbar_bptp@yahoo.com. (16 Juli 2009)
- Suhendra, Zulfi. 2013. Luas Lahan Pertanian RI Cuma Seperempat dari Thailand. <http://detikfinance.com>. (14 Juni 2013)
- Widodo, Sri. 2011. Konsep, Teori dan Paradigma Pembangunan Pertanian dalam Pembangunan Pertanian: Membangun Kedaulatan Pangan. Gadjah Mada University Press.
- Yuwono, Triwibowo. 2011. Membangun Kedaulatan Pangan, Membangun Kedaulatan Bangsa dalam Pembangunan Pertanian: Membangun Kedaulatan Pangan. Gadjah Mada University Press.

POTENTIAL OF THERMOTOLERANCE ISOLATES BACTERIA FROM THE LAND THAT AFFECTED BY MERAPI ERUPTION AS A PLANT GROWTH PROMOTING RHIZOBACTERIA (PGPR)

Yanisworo Wijaya Ratih and Lelanti Peniwiratri.

Agrotechnology Department, Faculty of Agriculture, UPN "Veteran" Jurusan Agroteknolog,
Fakultas Pertanian, UPN "Veteran" Yogyakarta. Indonesia

woro.yanis@yahoo.com

ABSTRACT

Merapi volcano erupted on October-November 2010 and destroyed any vegetations on the land affected by the eruption. A month after erupted, some plants: bananas, bamboos, grass, keladi starting to growth. There was an association between plant root and microorganisms. The present study was conducted to obtain a thermo tolerance isolates bacteria and to describe the potential of the isolates as a PGPR. The bacterial were isolated from rhizosphere of the start growing plants. The viability isolates were tested gradually on incubation temperature from 55°C to 100°C for 24 hours. The isolates that viable on 100°C, designated as a thermo tolerance bacteria. The parameters which were analysis were IAA production, nitrogenase activity, phosphate solubilization, and pH. A total of 9 thermo tolerance bacterial isolates had been isolated. According to the sequence of their 16S-rDNA, they were identified as *Bacillus* sp. (5 isolates), *Paenibacillus* sp. (2 isolates) and *Arthrobacter* sp. (2 isolates). All of the thermo tolerance isolates were able to produce IAA. The production of IAA ranges from 6.5 mg L⁻¹ (in *Bacillus* B1e) to 75 mg L⁻¹ (*Bacillus* B1b), where as the capability of isolates to solubilizing phosphate ranges from 0.95 mg L⁻¹ to 1.37 mg L⁻¹. All of the isolates had relative low ability to fixed N₂.

Key words: thermo tolerance, bacteria, Merapi-eruption, PGPR

INTRODUCTION

Merapi volcano erupted on Oktober-Nopember 2010. The eruption ejected a tremendous amount of volcanic material on and around the volcano. Wide agricultural areas around the volcano were destroyed by the volcanic materials. A month after eruption, some plant: bananas, bamboos, grass, keladi starting to growth. They would be a thermotolerance plants. There was an association between plant root and microorganisms. The associated bacteria must be has same characteristics, thermo tolerance also.

Rhizosphere is the soil found around the root and under the influence of the root. It is a site with complex interactions between the root and associated microorganisms (Sylvia *et al.* 1998). Plant-bacterial interactions in the rhizosphere are the determinants of plant health and soil fertility. Plant growth-promoting rhizobacteria (PGPR) are free-living soil-borne bacteria that colonize the rhizosphere and enhance the growth of plants

(Kloepper 1980). These organisms affect plant growth directly by fixation of atmospheric nitrogen, solubilization of minerals such as phosphorus, or by production of plant growth regulators (phytohormones), or indirectly by improving growth-restricting conditions either via production of antagonistic substances, by inducing resistance against pathogens, and by improving soil properties by leaving organic residues (Khan et al., 2009).

The role of microbial as a PGPR in productivity of crops not fully exploited for the benefit of crop improvement under different agro-ecosystems. The beneficial PGPR in plant growth promotion are very often region-specific besides soil-specific in natural ecosystems (Saharan and Nehra, 2011). PGPR have resulted in positive responses under controlled (laboratory and greenhouse) conditions; however, natural variations make it difficult to predict how PGPR may respond when applied to field conditions.

The present study was conducted to obtain a thermo tolerance isolates bacteria and to describe the potential of the isolates as a PGPR This research very attractive to be done because the thermo isolates have been isolated are indigeneous bacteria from locally region that affected by volcanic eruption. These isolates could be suitable applied in the regions that potentially affected by volcanic eruption, that are to be found in many regions in Indonesia. Volcanic eruption is repeated. The isolates bacteria may be still viable when eruption repeating, because they are thermo tolerance bacteria.

MATERIALS AND METHODS

A. Isolation and identification

The bacterial were isolated from rhizosphere of the start growing plants. The viability isolates were tested gradually on incubation temperature from 55°C to 100°C for 24 hours. The isolates that viable on 100° C, designated as a thermo tolerance bacteria. The isolates were identified based on the 16S rDNA gene sequences. 16S rRNA gene was amplified using the set of primers 27F (*Escherichia coli* position 8-27, 5'-AGA GTT TGA TCC TGG CTC AG-3') and 1492R (*Escherichia coli* position 1510-1492, 5'-GGC TAC CTT GTT ACG ACT T-3'). DNA sequence of the 6S rDNA fragments was compared using BLASTN at <http://www.ncbi.nlm.nih.gov/BLAST/>.

B. Determination of IAA production (Gravel et al., 2007)

Auxin (IAA) production by the isolated bacteria was initially determined through colorimetric analysis using Salkowski's reagent. Liquid cultures were prepared in Nutrient Broth supplemented with L-tryptophan. The culture was mixed vigorously with Salkowski's reagent. The mixture was incubated at room temperature for 20 min and the absorbance was measured at 535 nm. The concentration of IAA was evaluated by comparison with a standard curve.

C. Determination of Nitrogenase Activity (Belimov et al., 1995).

Nitrogenase activity was analyzed by acetylene reduction assay (ARA) method. Liquid cultures were prepared in Jensen's N-free. Atmosphere containing 10 % acetylene (v/v), which was achieved by removing air and replacing with equal volume of acetylene,

were added to the vials. At 24 hour intervals the gaseous phase was injected into a gas chromatograph (GC) equipped with flame ionization detector (FID) and a Porapak N column, in order to assay ethylene concentration.

D. Determination of phosphate solubilization (Grover, 2003; Nenwani *et al.*, 2010) and pH

Liquid cultures were prepared in Pikovskaya's medium were added $\text{Ca}_3(\text{PO}_4)_2$. Soluble P of the culture was analyzed by chlorostannous reduced molybdophosphoric acid blue method. The blue color intensity of the solution was measured at 600 nm. The pH of the cultures was measured by pH meter.

RESULT AND DISCUSSION

A. Isolation and identification

A total of 11 thermo tolerance bacteria had been isolated from rhizosphere of bamboos or grass. Based on the examination on the similarities of the cells and colony morphology of isolates, nine have been selected. The identification of isolates bacterial are presented in table 1.

Table 1. Thermo tolerance bacteria isolated from a rhizosphere of bamboos or grass

Strain no.	Code	Identify by 16S rRNA sequence	Isolates sources
1.	B1b	<i>Bacillus</i>	Rhizosphere of bamboos
2.	B1c	<i>Arthrobacter</i>	Rhizosphere of bamboos
3.	B1L	<i>Arthrobacter</i>	Rhizosphere of bamboos
4.	R32	<i>Paenibacillus</i>	Rhizosphere of grass
5.	R36	<i>Paenibacillus</i>	Rhizosphere of grass
6.	R310	<i>Bacillus</i>	Rhizosphere of grass
7.	Rtn36	<i>Bacillus</i>	Rhizosphere of grass
8.	Btn59	<i>Bacillus</i>	Rhizosphere of bamboos
9.	B1e	<i>Bacillus</i>	Rhizosphere of bamboos

According to the sequence of their 16S-rDNA, they were identified as *Bacillus* sp. (5 isolates), *Paenibacillus* sp. (2 isolates) and *Arthrobacter* sp. (2 isolates). *Bacillus* and *Paenibacillus* are gram-positive, aerobic or facultative aerobic, they are spore-forming bacteria therefore *Bacillus* and *Paenibacillus* survival when Merapi erupted. *Bacillus* and *Paenibacillus* commonly found in rhizosphere. Garbeva *et al.*, 2003 (in Antoun and Prevost) showed that the majority (95%) of gram positive bacteria are *Bacillus* and *Paenibacillus* species. *Arthrobacter* is gram positive bacteria minority in soil.

B. Determination of IAA production

Figure 1 represents the IAA production of isolates at 0, 2 and 4 days of incubation. All the isolates showed differential capacities to produced phytohormones Indole-3-acetic acid (IAA). The highest amount of IAA was produced by the strain *Bacillus* B1b. The IAA production of the isolates ranging from 6.5 mg L^{-1} (in *Bacillus* B1e) to 75 mg L^{-1}

(*Bacillus* B1b). Egamberdieva (2008) reported that ranging from 0.9 mg L⁻¹ to 1.75 mg L⁻¹ of IAA was produced by *Bacillus* strain, isolated bacteria from rhizosphere of wheat, whereas Erturk et al. (2010) showed that *Bacillus* and *Paenibacillus* were found to produce IAA in concentration of 33.6 and 32.8 mg L⁻¹, respectively.

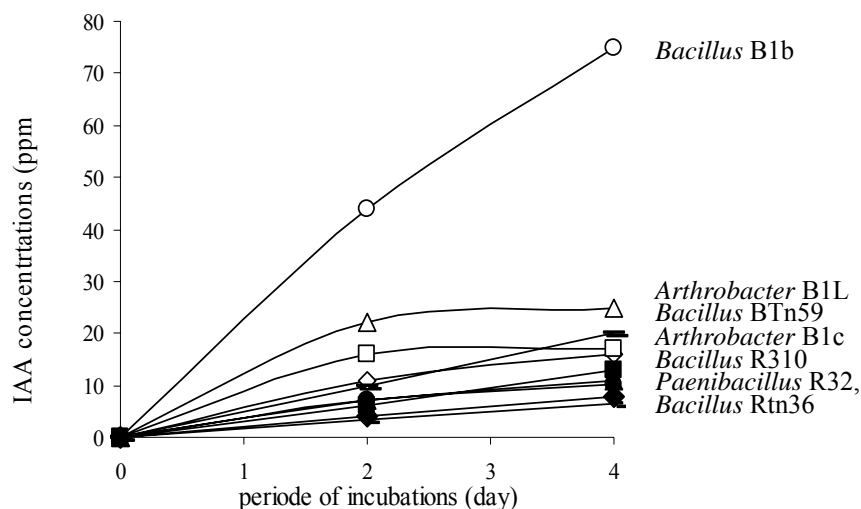

Figure 1. Production of phytohormones by thermo isolates

The major factor considered to be responsible for growth promotion by plant growth-promoting bacteria is auxin production. *Bacillus* sp. has been widely studied as plant growth promoting rhizobacteria producing phytohormones. Effect of the bacterial strains on the growth of the plants was studied by inoculating *S. tuberosum* sprouts and comparing various growth parameters of inoculated plants with non-inoculated treatments. Bacterial inoculation improved the plant growth by increasing shoot length approximately 40% and root length up to 42%, approximately 66% increase in the number of leaves, as compared to the control plants. Enhanced mineral and nutrient uptake ability due to bacterial inoculation promotes plant growth (Ahmed and Hasnain, 2010). Auxins act as long-distance signals controlling many developmental processes of the plants either directly or indirectly. Stimulatory effects of auxin-producing bacteria on root morphogenesis and development have been reported in various studies, which results in enhanced root surface area and increased root elongation. Increase in root length and surface area stimulates efficient water and nutrient uptake, which in turns effects the overall development and growth of the plants (Etesami et al., 2009). (Kidoglu et al., 2007).

C. Determination of nitrogenase activity

Figure 2 and 3 represents the nitrogenase activity and cells population of the thermo isolates. The result show that *Paenibacillus* R32, *Bacillus* R310 and *Bacillus* Bie had better nitrogen fixation ability than the other isolates. The nitrogenase activity of *Paenibacillus* R32, *Bacillus* R310 and *Bacillus* Bie were 0.61; 0.88 dan 0.54 μmol etilen/ml culture/day respectively, whereas the ability of the other isolates ranging from 0.15 to 0.17 μmol etilen/ml culture/day. Cell population of *Paenibacillus* R32, *Bacillus*

R310 and *Bacillus* Bie were log 6.3; 7.5 dan 7.9, respectively; whereas population of the other isolates ranging from log 6.6 to 7.95.

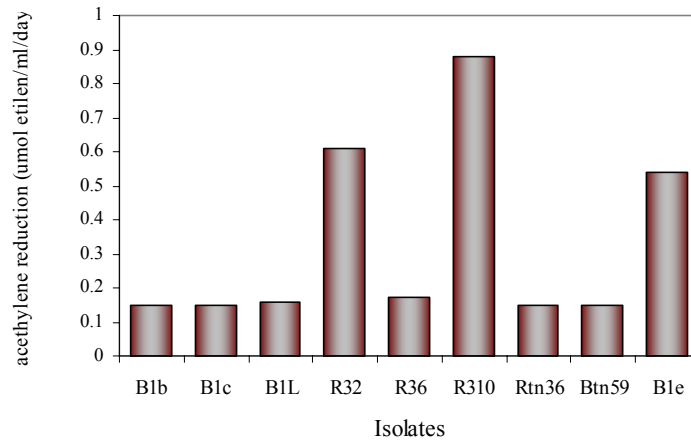

Figure 2. Nitrogenase activity of the thermo isolates

Nitrogen is required in large quantities by most agricultural plants through their growth period. Many different N₂ fixing bacteria have been isolated from the Rhizosphere. Soil microorganisms can provide nutrients to plants through the fixation of atmospheric N₂. Numerous studies have shown that different species of bacteria fix atmospheric N₂ and consequently affect growth and yield of various crops (Khalid et al., 2009).

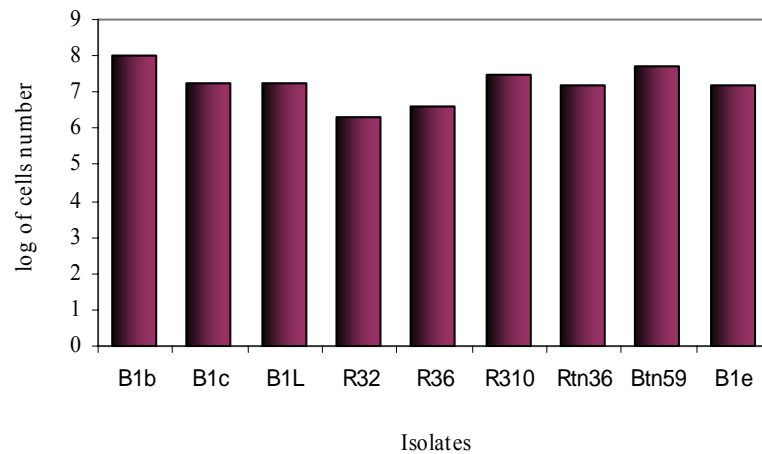

Figure 3: Cells number of the isolates

D. Determination of phosphate solubilization

Figure 4 and 5 represents the phosphate solubilization ability of the selected thermo isolates and pH changes at four weeks of incubation. Based on the examination on growth of the thermo isolates on Pikovskaya's solid medium, five isolates have been selected. The highest amount of soluble phosphate was produced by *Bacillus* B1b. After 4 weeks of incubation, a 1.37 mg/l of soluble phosphate was produced by *Bacillus* B1b, and the pH values of the cultures were reduced from 7 to 4. The phosphate

solubilization was due to the acidification of the culture by bacterium. Phosphate solubilizing bacteria such as species of *Bacillus* and *Paenibacillus* have been applied to soils to specifically enhance the phosphorus status of plants (Brown 1974)

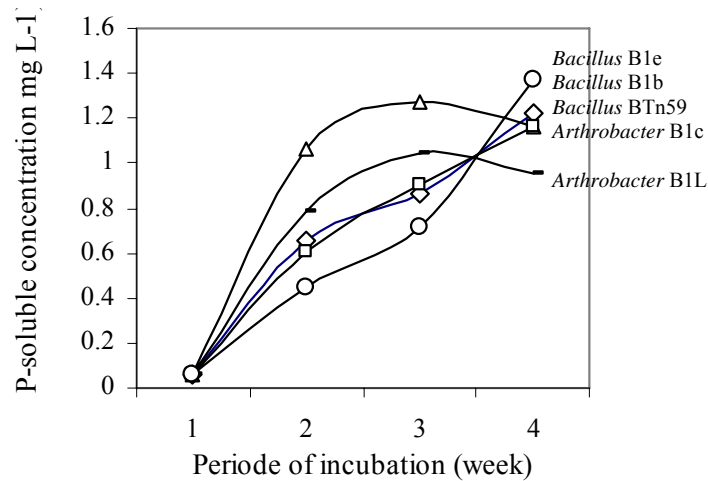

Figure 4. Production of soluble phosphate by selected thermo isolates

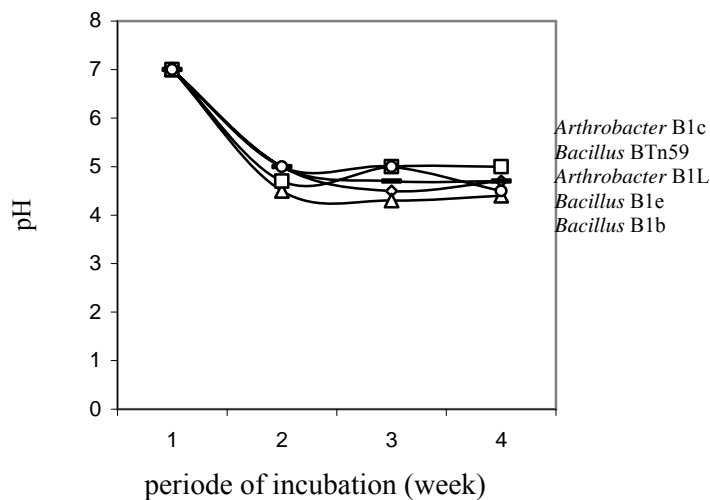

Figure 5. Changes of pH values of the cultures

Plant growth is frequently limited by an insufficiency of phosphates, which are considered one of the most important growth-limiting environmental factors. The low solubilities of common phosphates, such as $\text{Ca}_3(\text{PO}_4)_2$ hydroxyapatite and aluminum phosphate cause low phosphate availability. However, because some bacteria can solubilize insoluble phosphates, they may promote plant growth (Rodríguez and Fraga, 1999). Several reports have suggested that PGPR can stimulate plant growth through their P-solubilizing activity. The assimilation of nutrients, such as N, P, and K, in plants increased in response to inoculation with P-solubilizer (*Bacillus megaterium*) and K-solubilizer (*Bacillus mucilaginosus*). Inoculation with a phosphate-solubilizing *Bacillus* strain M3 significantly improved P, Fe, and Mn contents of the leaves of raspberry (*Rubus idaeus*), suggesting that *Bacillus* M3 alone or in combination with some other

strains had the potential to increase the nutrition of raspberry plants, in addition to growth and yield (Khalid et al., 2009). The results suggest that among the nine isolates, the *Bacillus* B1b isolate had the highest ability to produce IAA. Based on the ability of the isolates to produce IAA, the *Bacillus* B1b was the most potentially as a PGPR.

CONCLUSION

Nine thermotolerance isolates bacteria have been isolated from the land that affected by merapi eruption. They were identified as *Bacillus* sp. (5 isolates), *Paenibacillus* sp. (2 isolates) and *Arthrobacter* sp. (2 isolates). All of the thermo tolerance isolates had ability to produce IAA and solubilize insoluble phosphates. Based on the ability of the isolates to produce IAA, the *Bacillus* B1b was the most potentially as a PGPR.

REFERENCE

- Ahmed, S. and Hasnain, S. 2010. Auxin-producing *Bacillus* sp.: Auxin quantification and effect on the growth of *Solanum tuberosum*. *Pure Appl. Chem.* 82: 313–319
- Antoun, H. and Prevost, D. 2006. Ecology of plant promoting rhizobacteria. Dalam: Siddiqui (ed.), *PGPR: Biocontrol and Biofertilization*. Springer. Netherlands. 1-38.
- Belimov, A. A., Kojemiakov, A.P., and Chuvarliyeva, C.V. 1995. Interaction between barley and mixed cultured of nitrogen fixing and phosphate-solubilizing bacteria. *Plant and Soil.* 173:29-37.
- Dobbelaere, S., Vanderleyden, J., Okon, Y. 2003. Plant growth promoting effects of diazotrophs in the rhizosphere. *Critical Rev Plant Sci.* 22: 107-149.
- Gravel, V., Antoun, H., Tweddell, R.J. 2007. Growth stimulation and fruit yield improvement of greenhouse tomato plants by inoculation with *Pseudomonas putida* or *Trichoderma atroviride*: Possible role of indole acetic acid (IAA). *Soil Biology & Biochemistry* 39: 1968–1977
- Grover, R. Rock phosphate and phosphate solubilizing microbes as a sources of nutrient for crops. Desertation. Department of Biotechnology and Environmental Sciences Thapar Institute of Engineering and Technology. Patiala. 2003.
- Guemouri-Athmani, S., Berge, O., Bourrain, M., Mavingui, P., Thiéry, J.M., Bhatnagar, T., Heulin, T. 2000. Diversity of *Paenibacillus polymyxa* populations in the rhizosphere of wheat (*Triticum durum*) in Algerian soils. *Euro J Soil Bio* 36: 149-159.
- Khalid, A., Arshad, M., Shaharoon, B. and Mahmood, T. 2009. Plant Growth Promoting Rhizobacteria and Sustainable Agriculture in Khan, M. S., Zaidi, A. and Musarrat, J. (Editors). *Microbial Strategies for Crop Improvement*. Springer-Verlag Berlin Heidelberg.
- Kloepper, J.W., Leong, J., Teintze, M., Schroth, M.N., 1980. Enhanced plant growth by siderophores produced by plant growth promoting rhizobacteria. *Nature*, 286: 885–886.

- Nenwani, V., Doshi, P., Saha, T., and Rajkumar, S. 2010. Isolation and characterization of a fungal isolate for phosphate solubilization and plant growth promoting. Available online <http://www.academicjournals.org/JYFR> © 2010 Academic Journals
- Rodríguez, H., and Fraga, R. 1999. Phosphate solubilizing bacteria and their role in plant growth promotion. *Biotechnology Advances* 17: 319–339
- Saharan, B. S. and Nehra, V. 2011. Plant Growth Promoting Rhizobacteria: A *Critical Review*. *Life Sciences and Medicine Research*, Volume 2011: LSMR-21
- Sorensen, J., van Elsas, J.D., Trevors, J.T. 1997. The rhizosphere as a habitat for soil microorganisms. Dalam: Wellington, E.M.H. (ed) *Modern soil microbiology*. Marcel Dekker, New York, pp 21–45.
- Sachdev, D., Agarwal, V., Verma, P., Shouche, Y., Dhakephalkar, P. and Chopade, B. 2009. Assessment of microbial biota associated with rhizosphere of wheat (*Triticum aestivum*) during flowering stage and their plant growth promoting traits. *The Internet Journal of Microbiology*. Volume 7 Number 2
- Smit, E., Leaflang, P., Gommans, S., Van den Brock, J., van Mil, S., Werners, K. 2001. Diversity and seasonal fluctuation of the dominant members of the bacterial soil community in a wheat field as determined by cultivation and molecular methods. *Appl. Environ. Microbiol* 67: 2284-2291.
- Tsavkelova, E.A., Cherdyntseva, T.A., Klimova, S.Y., Shestakov, A.I., Botina, S.G., Netrusov, A.I. 2007. Orchid-associated bacteria produce indole-3-acetic acid, promote seed germination, and increase their microbial yield in response to exogenous auxin. *Archives of Microbiology*. 188: 655-664.

THE APPLICATION OF PGPR (*Plant Growth Promoting Rhizobacteria*) on CHILI PLANT AS AN INTERPOSED PLANT BETWEEN SALAK PLANT IN SUB-DISTRICT SRUMBUNG

Ellen R. Sasmita, Sri Sumarsih, Oktavia S. PadminidanEndah B. Irawati

Agrotechnology Department, Faculty of Agriculture

University of Pembangunan Nasional "Veteran" Yogyakarta

Jl. Lingkar Utara 104 Condongcatur, Yogyakarta

Email: ellensasmita@gmail.com

ABSTRACT

Chili plant is chosen as the interposed plant between salak plant in Srumbung Subdistrict, Magelang Regency, because it has a high selling value and stable so it can be a source of additional income for the farmers given their plants haven't been able to generate post salak eruption of Merapi. In addition, planting chili indirectly would help cultivate and nurture the soil around salak plants. PGPR application will spur the growth of chili plants in absorbing the nutrients. The research aims to find out the effect of PGPR application on growth and yield of chili plants. This research is using Split Plot Design factorial with three times replication. The main plot is by soaking the seed of chilies with PGPR, consists of two borders, and the sub-plot is by PGPR watering frequency swath is composed of four levels. The result showed that the application of PGPR is able to increase growth and crop yield of chili; there is an interaction between soaking seed chili and the frequency of PGPR watering; the best combination of treatment is P1F2 (soaking seeds with PGPR and frequency of watering PGPR once every two weeks)

Keywords: chili, PGPR

INTRODUCTION

Salak plant is a staple crop that is grown in Sub-district Srumbung District Magelang. Srumbung is the largest area in producing salak pondoh in Magelang, with one of the varieties preëminent produced issalak Nglumut. The problem faced by salak farmers are due to Merapi eruption the end of October 2010 is the impact of the heavy damage against the plantation of salak. Due to tampering with salak plantation, the Merapi eruption maketheeconomic activity society declined because to salak couldn't give results like in the previous era, so farmers do not have their income from their salak plantation

This problem needs to get attention from various parties. One of the solutions in solving this problem is the effort of planting interposed crops. Annual interposed plant is a plant that is grown among a perennial plant that arranged regularly in form up straight. The

cultivation of plants interposed on the land salak chosen as a solution to start the process of recovery kebunsalak it is expected that farmers being productive back. The cultivation of plants interposed in the salak plantation is a new thing for the people in srumbung, so that it takes the process of the transfer of technology.

The planting of interposed crops with annual plants among plants can be a choice, because it can be harvested quickly and will indirectly cultivate the land around salak plants. Cultivation of the land to blend a layer of volcanic ash that resulted from Merapi eruption to the ground eradicates impermeable layer that interferes with the drainage land and will reduce puddle when it rains. Good drainage will dissolve the ingredients that cause the ground to be acerbic. Selected commodities as interchanged crops are the value plants and also stable, for example chili. Wati's finding (2004) about the cropping pattern of chili as the plant broke in at the village of salak plants among Sudimoro, Magelang, showed no adverse side effects to the growth and production of both crops. The expectation with the plant between farmers will have an additional source of income while awaiting the salak which became his life during these hangers can generate returns with a high productivity.

Chili is a plant genus Capsicum. Its fruit can be used as vegetables, herbs or drugs, depending on the intended use. Spicy chili fruits are very popular in the community as the amplifier sense of food. In the food industry, chili powder extract used as the substitution of pepper to arouse appetite and flavoring dishes, also used in the manufacture of herb medicines (pharmaceutical industry), industrial food coloring, mix ingredients on a variety of food and beverage processing industry as well as the producer of essential oils (Cahyono, 2003). In Indonesia the great chili differentiated into two groups, the large red chilli and chilli red curls. The striking difference between the two types of chili are on the shape of the fruit and spicy flavours. Big red chili fruit surface is smooth and had spicy taste, while the curly shaped chili is very spicy.

Strategy to increase the growth and results chilis by using PGPR (*Plant Growth Promoting Rhizobacteria*) or rhizobacteria. Rhizobacteria is that bacteria that live and flourish in the vicinity of rooting plants. Rhizobacteria can serve as pacemaker of the growth of plants and as agents antagonistic to plant pathogen (Timmusk, 2003 *cit.*, Taufik, 2010). The advantage of the usage of rhizobacteria is that, it has no danger or hazard side effects so that the environmental pollution can be avoided. Several species of rhizobacteria capable of increase of growth in plants genus-genus rhizobium, among others azotobacter, azospirillum, a bacillus, arthrobacter, bacterium, mycobacterium and pseudomonas (Biswas *et al.* , 2000).

Plant Growth Promoting Rhizobacteria (PGPR) is a group of bacteria that live and thrive well in soil that is rich in organic material (Compant *et al.*, 2005 *cit.*, Kamila *et al.*, 2013). This bacterium is known to be active in the area of colonized plant roots and has three main roles for the plant, namely: (1) as a biofertilizer, PGPR is able to accelerate the process of plant growth through accelerating absorption of nutrient elements, (2) as biostimulan, PGPR can spur plant growth through the production of fitohormon, and (3) as bioprotection, PGPR protect plants from pathogen (Rai, 2006).

This research aims to know the effect of PGPR application on growth and yield of pepper plants and to determine the most appropriate PGPR application for crop growth and yield of pepper.

MATERIALS AND METHODS

The research was carried out in the hamlet of Chili Lor Village Sub-district, Magelang Regency Sumbing in August 2011 to February 2012 with an elevation of 501 m above the sea level. The type of soil is regosolvolcanic ash. The materials and tools used is the chili seed TM 999; Rabbit manure; PGPR; Silver black plastic mulch (PHP); Fertilizer: Urea, ZA and KCl; Agrymicin/Agrept. The instrument used was a polybag for, measuring cup, ruler, tool trap pests fruit, analytic weights, ropes and bamboo.

This research is using split plot design factorials consisting of two factors with three deut.. As the main plot is soaking seed chilli with PGPR consisting of two cedar namely: P1: soaked PGPR and P2: no soaked PGPR. As the sub plot tenement is the frequency of watering PGPR consisting of four cedar namely: F0: no watered, F1: once a week watered, F2: watered twice a week, and F3: watered thrice a week. There are eight combination treatment.

Implementation research beginning with the chili seed nurseries, aims to provide a quality seed in sufficient quantities. Before the seeds are spread, first we need to select the good seeds. The next fed chili seed treatment by soaking in a solution of PGPR with concentrations of 10 ml per liter of water for 1 hour. Then the seeds are stocked in polybags for the media, one polybag planting one seed, right in the middle of polybags as deep as 1-1.5 cm, then covered with thin soil again. After the seedlings reach age 25 days and has equipped 2-4 helaian leaves, seed began to be moved to the plantation.

Before seedlings are grown, the ground among plants salak has been treated first as deep as of 30 cm to the circumstances of being friable, more fertility and free from weeds. Clipping the stem bark of salak that damaged because of eruption be programmed into the ground, next made bedengan rude. At the moment, land given lime agriculture with a dose of 1.5-2 ton / ha or 150-200g / meters. Seedbed land made with long 12 m, and the height 120 cm wide 40 cm. Mix together manure a rabbit, cangkul back so as to unevenly with the ground. At this stage seed bed land then given fertilizer inorganic Urea, Za, and KCl, each 200 kg, 600 kg and 350 kg. / ha, mix together evenly to a depth of 25 cm. Mulch with black plastic silver mounted black position overlooking the ground, will give a darker conditions against the media making it possible to grow better rooting; While the silver color facing out, it can reflect sunlight so that the amount of heat on the surface can be reduced and the reflection of light can help accelerate the loss of water vapor that is stuck to the surface of the leaves of the plant.

The hole on mulching made by pasting a pit mulching, in the range of transplanting 50 centimeters x 50 centimeters. The depth of a hole cropping made on a hole mulching by means of digging in the ground about 8-10 cm. Bibit to be planted selected beforehand, selected bibit a healthy and uniform its growth. Before seedlings are grown, bibit and

polibagnya dipped in solution agrimycin / agrept by concentration of the 1.2 g4 / 1 water, intended to prevent pathogen that may be developed in the field. Next plastic polibag opened, seedlings are grown and direct watered water until the conditions are moist.

A solution of PGPR made by concentration of the 5 per liter of water. The application of the treatment, PGPR carried out in accordance once a week, two weeks once and three weeks for until, ahead of flowering plants by means of a splashed as many as 1-2 glass aqua solution last to the region of rooting plants.

Maintenance activities executed is revoke the axillary buds, replace dead plants, installing bamboo plants for bonding, fertilizing follow-up irrigation (as needed plant); weeding weed among bedengan and control pests disease (setting up something like flies bibit).

Harvest is carried out at the age of 90 days after planting, with intervals of 3-5 days. Picking is done cautiously so that new and young fruit flowers don't fall out, by way of a plucked fruit stalks are accompanied.

The observed parameters include plants height, branches height, flower appereance, the number of fruits and fruit weight amount per plant every harvest. The data were analyzed using yout observations range on the real level of five percent. To tell the difference between the influence of the treatment performed Duncan Multiple Range Test on a real level of five percent.

RESULTS AND DISCUSSION

A. Plant Height of Chili

Based on the response of plant height of Chili, then it can be seen that the plant seeds are soaked in Chili PGPR (P1) and the seeds are not soaked PGPR (P2) shows a different plant. Plant that seed soaked with PGPR provide higher response. Soaking with PGPR gives the possibility for direct contact between the fitohormon with the seed-producing bacteria. So when the seeds germinate already affected by the fitohormon. Similarly on the plants watered with PGPR (F1, F2 and F3) showed higher plant height compared to plants that are not smothered with PGPR (F0) (Graph 1). According to Suriadikartaet *al.*, (2011), as a result of the eruption the population of microbes use as soil enricher is down, so with the granting of PGPR can increase microbial populations. In addition, the setting of the midrib pieces of barksalak when tillage can also improve the organic material needed by the microbes.

The ability of PGPR produces fitohormon make the plant can increase surface area of fine roots and increase the availability of nutrients in the soil. Research results Masnilahet *al.*, (2009), *cit.*, Kamilaet *al.*, (2013), indicate that PGPR can improve treatment plant root growth of soybeans compared to the control treatment. This causes the absorption of nutrient elements and the water can be done well, so plant growth shown by its vegetation is also a good high.

On the graph of 2 visible that at combination treatment provides high response P1F2 a better plant than other treatment combinations. This means that the granting of PGPR two

weeks once to plant chili gives a better nutrient adequacy than the granting of PGPR one week or three weeks once in a while. On the frequency of watering once a week is likely to occur in conjunction with the imobilisasiseresah plant refurbishment process salak embedded at the time of processing land.

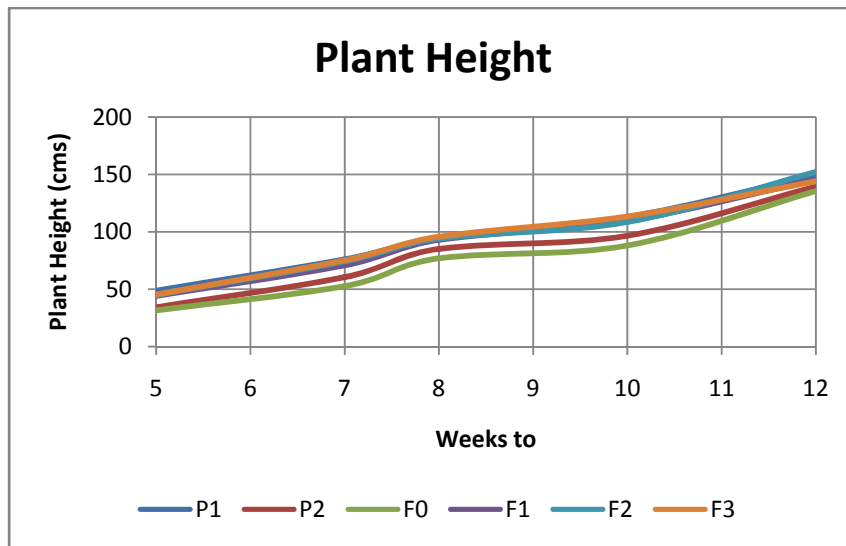

Graph 1. Chili Plant Height At Different PGPR Treatment

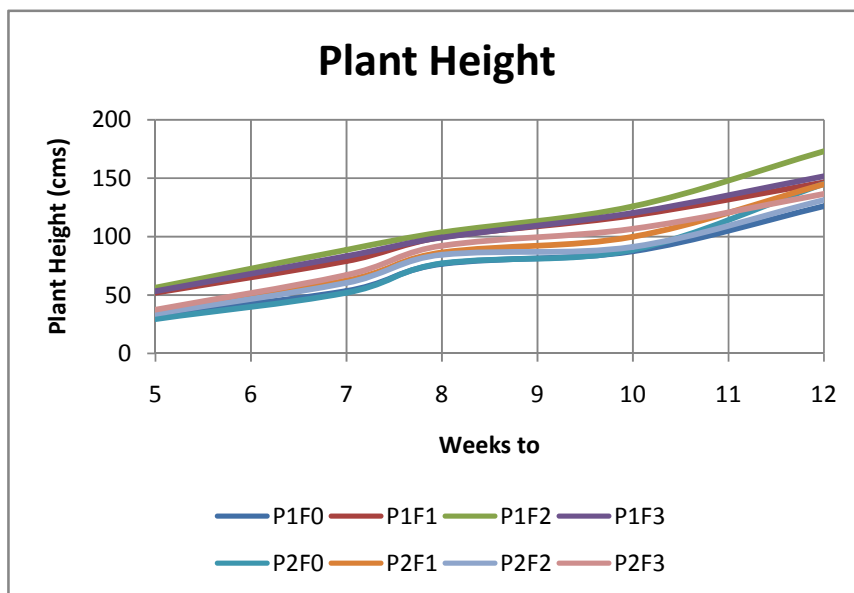

Graph 2. Chili Plant Height At Different Combinations Of PGPR Treatment

B. Branch Heightof Chili

Based on high the branch of response against the use of pgpr then can see that high branches on the seeds of being soaked PGPR (P1) and seeds that are not soaked PGPR (P2) indicating high branches diverging. A plant whose seeds are soaked with PGPR give a response that higher. Similarly in plants flushing with PGPR(F1, F2 and F3) indicating high the branch of higher than plants that do not flushing with PGPR (F0) (Graph 3).

PGPR improved plant growth hormones directly through growth produced as Giberelin and IAA. IAA growth hormone auksin group is useful to stimulate growth of plants. Auksin useful for stem cell, fueling growth the process of inhibiting pengguguran leaves cambium, and stimulate growth and hinder bud growth armpit (Tjondronegoroet *al.*, 1989 *cit.*, Kamilaet *al.*, 2013).

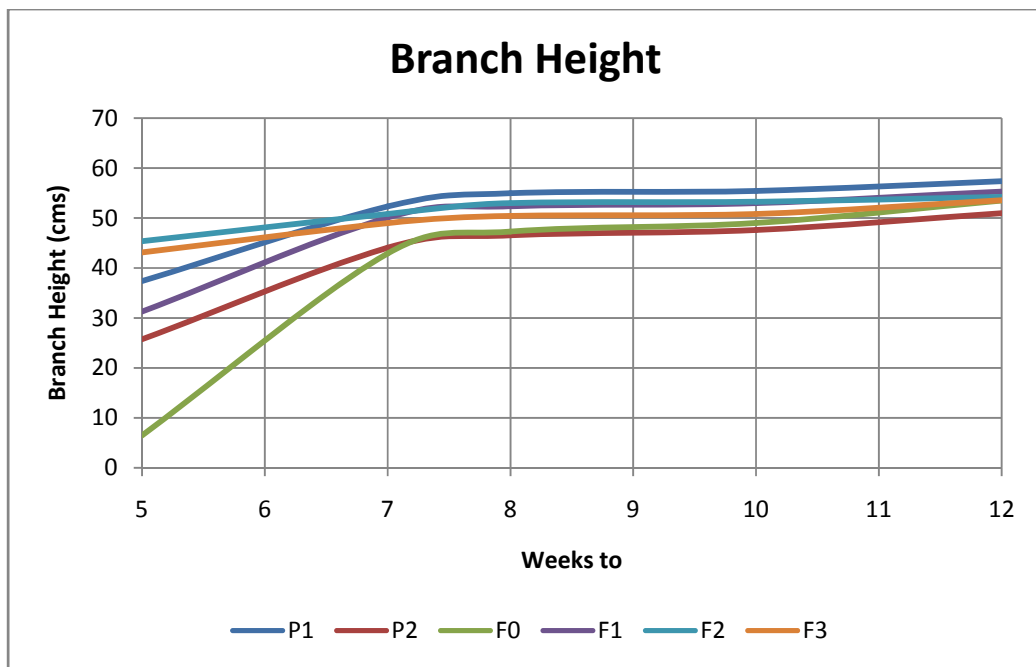

Graph 3. Branch Height On Different Treatment Of PGPR

On the graph 4 seen that combination treatment on P1F2 provide high response branch is better than other treatment combinations. This means that the granting of PGPR two weeks once to plant chili gives a better nutrient adequacy than the granting of PGPR one week or three weeks once in a while.

The results of research conducted by Maunuksela(2004) and Thakuriaet *al.*, (2004) showed that several groups rhizobakteria is as agens biodiversity that have the ability of a spur growth of crops. Rhizobakteri it is a native of a group of Bacillus spp. ,Pseudomonas

fluorescens and *Serratia* spp. , which has been reported is able to produce hormone grow like IAA. According to Taufik (2010), an research result of Taufik *et al.*, (2005 and 2010), that can improve the application PGPR chili growth of crops in the greenhouse. Inoculation agens biodiversity *Bacillus formis* through treatment on seeds before transplanting can increase the growth of plants and the results of the peanut more than 19 % compared to controls.

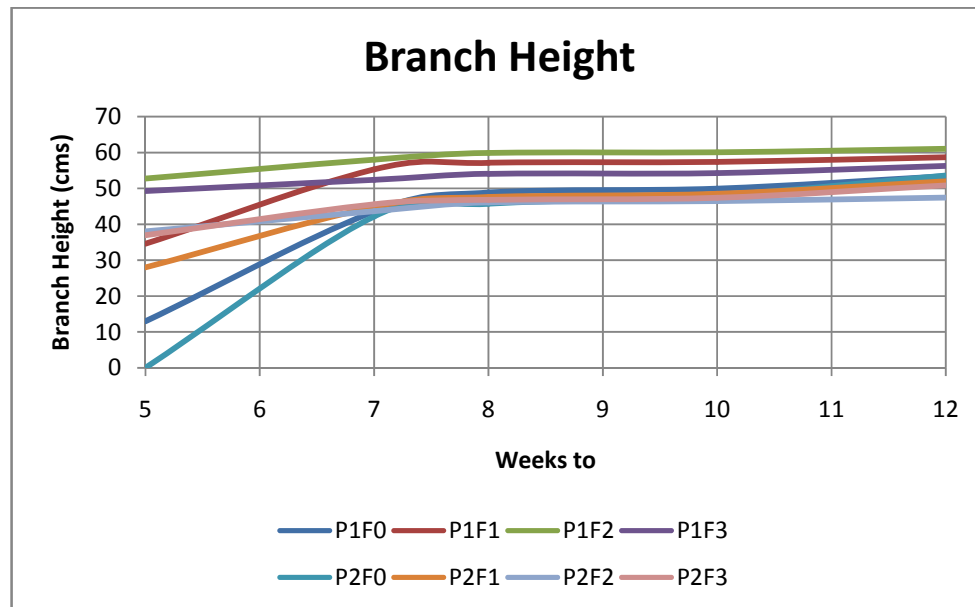

Graph 4. BranchHeight On Various Combinations Of PGPR Treatment

C. Flower Apperance

On a table 1 following this can be seen that there is an interaction between treatment of soaking basin PGPR on the emergence of seeds and flower chili. The appearance of flowers most quickly found in treatment P1F2, P1F3 and P2F2 which is 50 days after cropping, the three different from other treatment. Flowers appearing at most in treatment P1F0 and P2F0.

Observations show that the emergence of the generative flowers plants chili which is treated with PGPR faster than the control treatment. The role of PGPR in accelerating the emergence of interest allegedly related to his ability to synthesize the hormone grows challenged and IAA are useful to stimulate the emergence of a flower.

Table 1. The average of the flowers appearance chili (days)

Treatment		Frequency of PGPR Watering (F)				Average
		F0	F1	F2	F3	
Soaking the seed (P)	Soaked (P1)	66,00 a	59,33 b	50,00 c	50,00 c	56,33
	Not soaked (P2)	68,47 a	60,00 b	50,00c	59,33b	59,45
Average		67,26	59,67	54,67	50,00	(+)

Information: Figures in a column that followed the letter showed that there is no different real with the distance worship of idols duncan at the level of real five percent.

(+): there is the interaction

The number of fruits and fruit weight

The results of observations on the number of fruit chili (Graph 5 and 6) and weights fruit chilli(Graph 7 and 8), a graph showing the different treatment PGPR real treatment with control. Based on response number of fruits and fruit weight then can see that treatment combination P1F1 and P1F2 give the number of fruit and fruitweights more and more heavily than combination other treatment. Results achieved in P2F0 lowest treatment. The number of fruits and fruit weight increased significantly at harvest 7th and fluctuates 15th, until harvest after the fruit harvest and weights on each decreasing. The highest attainable fruit fruit and weights at harvest 10th.

The application of PGPR able to increase the number of fruit and the weight of the fruit. Rhizobakteri used in plants pushes productivity plant better caused by the accumulation of nutrient as N and P and other compound that is induced by these microorganisms were. The application of PGPR can affect the production of fruit. A mechanism directly done by PGPR namely by means of a metabolite e.g. mensintesia compound that stimulates the formation of fitohormon as IAA(IndoleAcetic Acid), or by raising adoption of plant nutrition. IAA is its active form of hormone auksin who be found in plants and played the role to improve the quality and yield harvest. The function of hormone IAA for plants among others, improve the development of the stimulates root formation of new spur growth, stimulates of flowering and increases the activity of an enzyme (Arshad and Frankenberger, 1993 *cit.*, Kamila (2013).

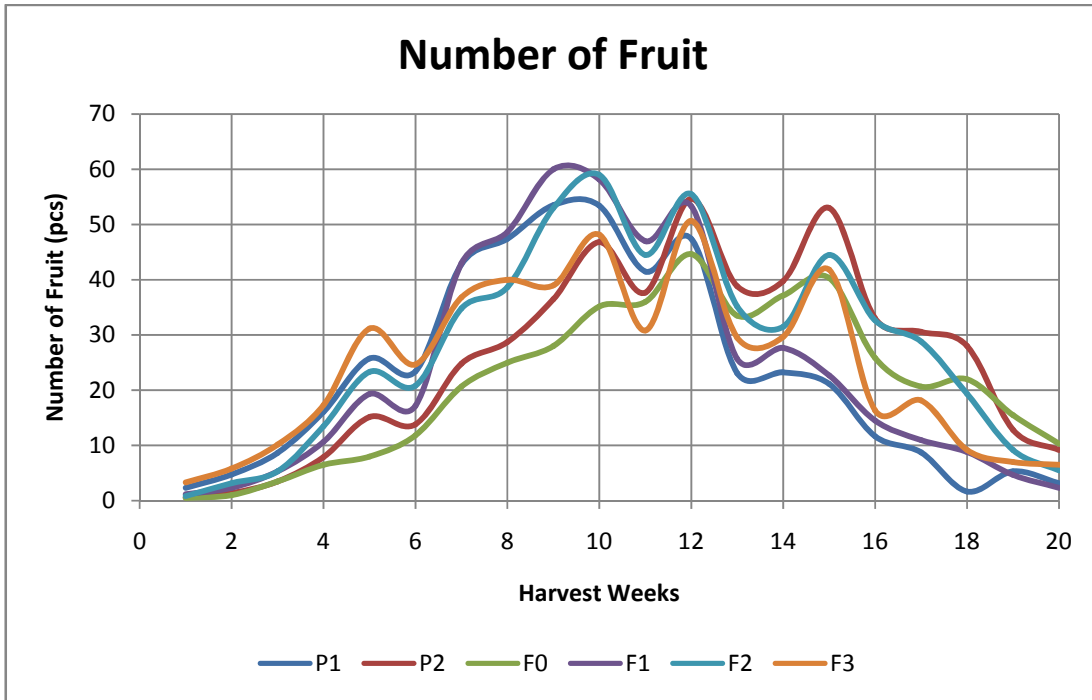

Graph 5. Number of Fruit On Various Treatment Of PGPR

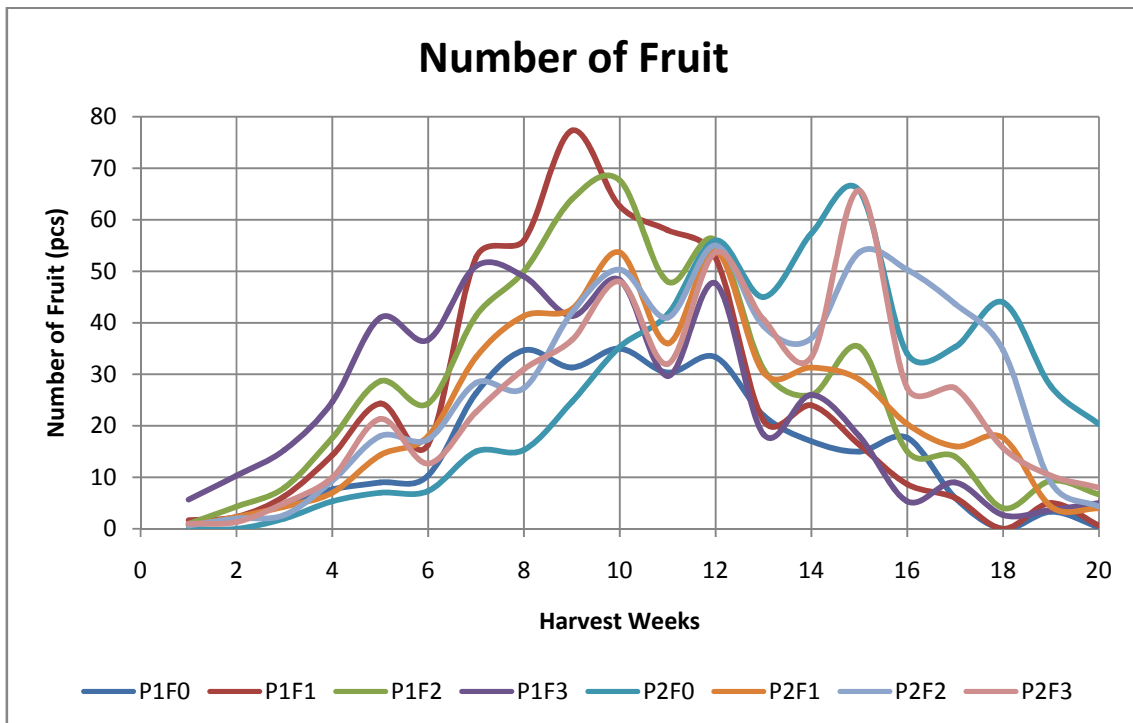

Graph 6. Number Of Fruit On Various Combinations Of PGPR Treatment

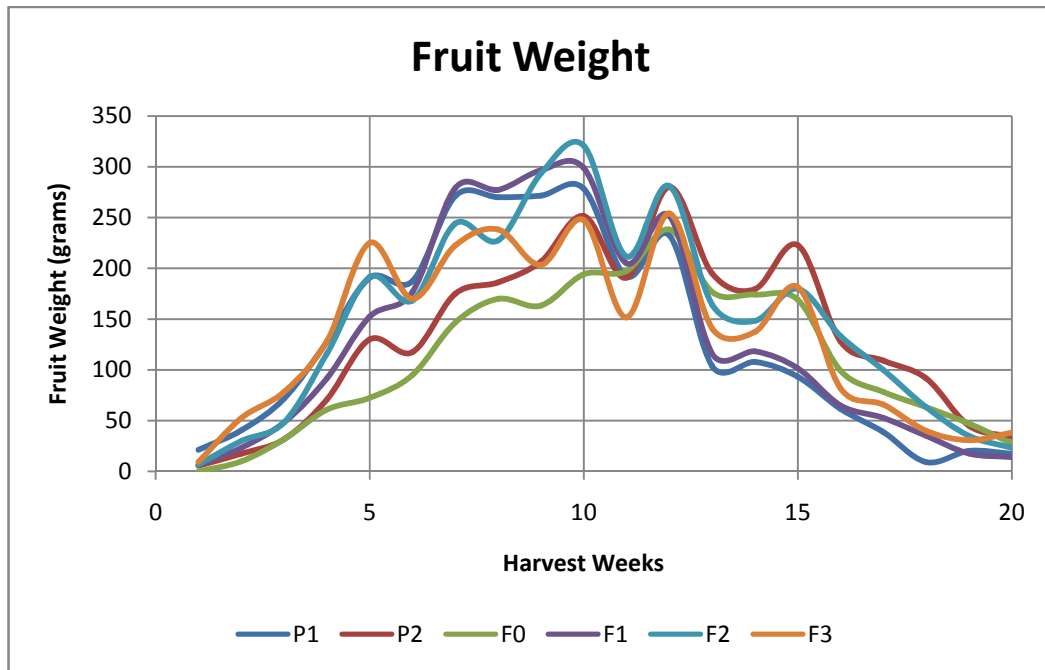

Graph 7. Weight of Fruit on Various Treatment of PGPR pgpr treatment

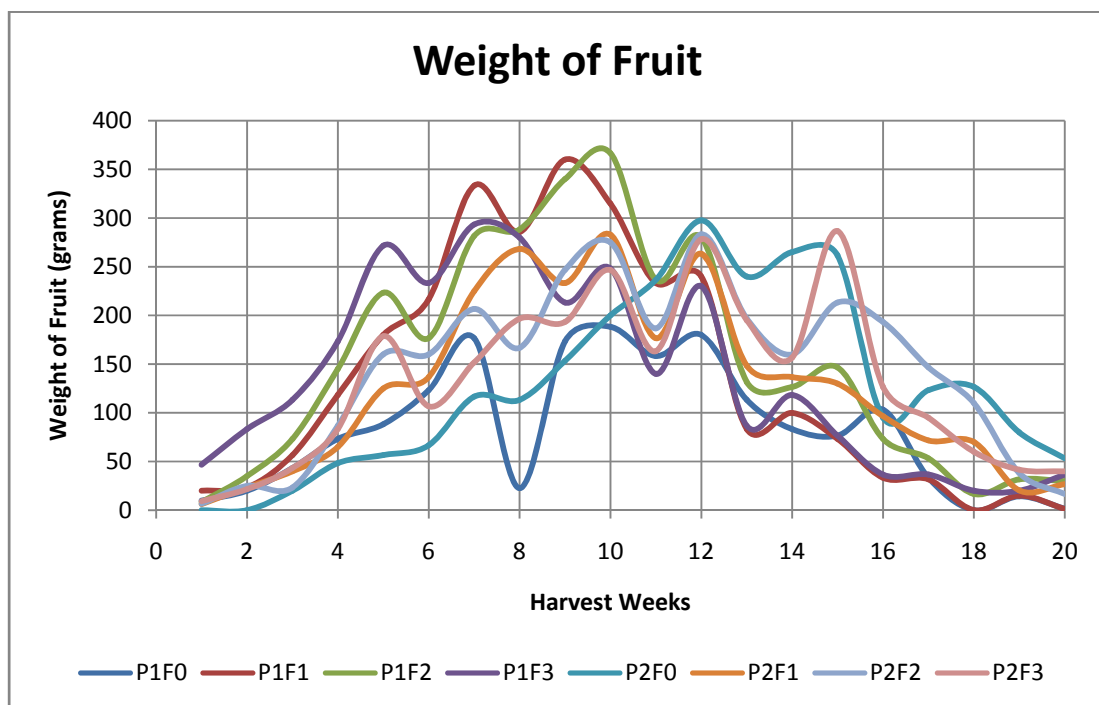

Graph 8. Weight of Fruit on Various Combinations of PGPR Treatment

CONCLUSION

Based on the above discussion of the description can be retrieved the following conclusions:

1. The application of PGPR is able to increase growth and chili yield crop.
2. There is an interaction between soaking seed the chilies with the frequency of watering PGPR towards growth and crop yield of chili.
3. The best combination of treatment is P1F2 (soaking seeds with PGPR and frequency of watering once every two weeks of PGPR)

REFERENCE

- Biswas, J.C., J.K. Ladha, F.B. Dazzo, Y.G. Yanni, and B.G. Rolfe.2000. Rhizobial Inoculation Influences Seedling Vigor and Yield of Rice. *Agron J.* 92:880-886
- Cahyono, B. 2003. *Cabai Rawit Teknik Budidaya dan Analisis Usaha Tani*. Kanisius. Yogyakarta
- Kamila, Q.A., T. Hadiastodon dan M. Martosudiro. Pengaruh Penggunaan PGPR (*Plant Growth Promoting Rhizobacteria*) Terhadap Intensitas TMV (*Tobacco Mosaic Virus*), Pertumbuhan dan Produksi Pada Tanaman Cabai Rawit (*Capsicum frutescens* L.). *Jurnal HPT Volume I Nomor 1 April 2013*: 47-56.
- Maunuksela, L. 2004. Molecular and Physiological Characterization of Rhizosphere Bacteria and Frankia in Forest Soils Devoid of Actinorhizal Plants. *Dissertationes Biocentri Wikki Universitatis Helsingiensis*. <http://ethesis.helsinki.fi/julkainst/mat/manuksela/molucela.pdf>. [19 Juli 2008]
- Rai, M.K. 2006. *Handbook of Microbial Biofertilizer*. Food Production Press. New York.
- Suriadikarta, D.A., A. Abbas., Sutono, D. Erfandi, E. Santoso., dan A. Kasno. 2011. Identifikasi Sifat Kimia Abu Vulkan, Tanah dan Air di Lokasi Dampak Letusan Gunung Merapi. Balai Penelitian Tanah. Bogor.
- Thakuria, D., N.C. Talukdar, C. Goswami, S. Hazarika, R.C. Boro and M.R. Khan. 2004. Characterization and Screening of Bacteria from Rhizosphere of Rice Grown in Acidic Soils of Assam. *Curren Sci.* 86: 978-985. http://www.bio.uu.nl/fytopath/pdf/files/Bookch.vanLoon_2003 [17 Maret 2010]
- Taufik, M. 2010. Pertumbuhan dan Produksi Tanaman Cabai Yang Diaplikasi Plant Growth Promoting Rhizobakteria. *J. Agrivigor* 10 (1): 99-107. September-Desember 2010.
- Wati, I. 2004. Efisiensi Pemupukan P-Alam yang Dikombinasikan dengan Pupuk Kandang Ayam untuk Tanaman Cabai Merah Pada Regosol di Kecamatan Srumbung Kabupaten Magelang. *Skripsi. Jurusan Ilmu Tanah. Fakultas Pertanian Universitas Pembangunan Nasional "Veteran" Yogyakarta*.

A STUDY OF IMPACT OF BRICK INDUSTRIES ON SOIL FERTILITY IN POTORONO BANGUNTAPAN BANTUL YOGYAKARTA

R. Agus Widodo and Susila Herlambang

Agrotechnology Departemen Faculty of Agriculture UPN "Veteran" Yogyakarta

Jl. Ringroad utara, Condongcatur Yogyakarta 55283 Phone/Fax. 0274-486737

* Corresponding author : r_aguswid@yahoo.com

ABSTRACT

Rapid growth of the city has been boosted demand for bricks, because it is one of the important building materials. Potorono village, Banguntapan district, Bantul regency, Yogyakarta is a center of brick industry arised to meet the demand from the surrounding area. Brick industry requires upper soil layer as raw material. This material is taken from the upper soil layer (top soil) of actually productive agricultural areas. As a result, this activity will cause problems of loss of top soil as planting medium that is rich in nutrients and humus. Mining of upper soil layer also resulted uneven soil surface and formed basins that will be flooded whenever precipitation occur. If this process continues, it is feared may lead to decreased fertility and productivity of land and will cause damage to the environment. This study was aimed to determine impact of soil mining for brick industry on soil fertility, especially its chemical properties. The research was conducted by survey and area descriptions situations. Soil sampling was done based on purposive method. The collected soil samples then were prepared for further analysis of chemical properties. Analysis was conducted for parameters of pH, organic-C, total-N, available-P, available-K and cation exchange capacity (CEC). The results showed that soil has slightly acid to neutral pH, very low to low organic matter and total-N content, very low to very high available-P content, low to very high available-K content and very low to moderate CEC. This indicates that organic matter, total nitrogen and CEC become limiting factors for soil fertility of post-soil mining for brick industry.

Keywords: *brick, topsoil, soil mining, fertility*

INTRODUCTION

Demand of building materials for housing continues to increase in line with population growth. One of the main material needed in housing construction is bricks. The brick industry uses clay soil as raw materials which generally taken from agricultural land. Many productive agriculture land has been converted into mining land for brick industrial materials. Soils mining activities for brick industry, both in paddy field and in dry land in Bantul has been critical. At least 650 hectares of wetland suffer damaged and disrupted irrigation facilities. Head of Bantul Agency of Agriculture, Edy

Suharyanto said that the damage primarily occurred in the Pleret, Banguntapan and Piyungan. As the three areas are located in lowland with enough water supply so that the fertility is better. If this activity is allowed to continue then the food security could be vulnerable because Bantul grain production is going down (Prihtiyani, 2010).

According to Suntoro (2006), soil which mined for making bricks and tiles is more suitable to fertile productive soils. Paddy soil excavation will destroy irrigation water (irrigation and drainage), will also be a process of losing the upper soil layer (top soil) that relatively more fertile, and left a layer of soil (sub-soil) that are less fertile, so the land then being unproductive. According to Singh (2001), soil sampling before and after the excavation showed that the fertility of the soil is down to 50%. Soil damage because of disruption of physical, chemical and biological characteristics is having influence on the decrease of crop production. Decline in rice production reached about 22% in semi-critical land, 32% on marginal lands, and an estimated 38% of land is very critical. As for the peanut decreased approximately 9%, 46%, 58% respectively on the semi-critical, critical and very critical land. Soil properties which correlated significantly to affect rice production is solum depth, and organic matter content (Sudirman and Vadari, 2000. *cit* Andriani, 2011). In addition, results of the study of Khan et. al. (2007) showed that the soil mining for making brick was significantly lower the pH of the soil, on the average of 0.4 units, but increase the average value of EC from 0.26 to 1.77 mS/cm and is associated with a function of soil depth. Average sand content of the soil increased 330%, while the content of silt and clay reduced respectively 49% and 40% according to the depths along the soil profile. The average loss of 63% organic matter, total and available N-P-K loss of 56% to 86% and S loss of 23% to 88% at any time after the combustion process.

Of the problems mentioned above, it is necessary to study the effect soil excavation on fertility and chemical properties of the soil. Study of soil fertility could be done by determining required soil analysis. According to Mutert (1995), the analysis can be limited by the parameters of the soil pH, N, P, and K as well as organic matter, while the analysis of another element considered as a supplement. This study was aimed to determine level of soil fertility on post mining activity of brick industry in Potorono village Banguntapan Bantul district of Yogyakarta province.

MATERIALS AND METHODS

The study was conducted in the village of Potorono, Banguntapan District, Bantul regency, from May to December 2011. This study was conducted by using field survey with reference of topographic map. Locations of soil sampling were determined purposively. Soil samples were taken from layers up to 30 cm depth. Then, the samples were analyzed in the Soil laboratory of Agrotechnology Department, Agriculture Faculty, UPN "Veteran" Yogyakarta. Analysis of soil chemical properties consisted of pH (pH meter), organic C (Walkley and Black), total N (Kjeldhal method), available P (Bray-1), available K (1 N NH₄OAc extracts), and cation exchange capacity (1 N NH₄OAc saturation). Soil analysis results obtained then were compared among soil sampling locations.

DISCUSSION

Soil which used for brick industry is top soil and usually fertile soil. This fact causes that post-excavated soil for brick industry becomes difficult for replanting. The remainder soil after excavation generally has lower fertility than native soil. This is due to ignorance of the local people, about the importance of restoring topsoil to the site of a former brick quarry land. Effort to restore soil functions as a land for agricultural production, has already begun in several locations of post mining land for the bricks production. However, it is experiencing a variety of problems due to soil infertility on mined land. In some locations of former brick mining land, crops have performed relatively tolerant to the low level of soil fertility due to mining activities. Several locations have been successfully planted with kolonjono grass, corn, soybeans, and rice. This takes a long time to achieve plant growth as expected. Results of chemical analysis of some soil properties of the post-mining for brick industry in the village Potorono bricks can be seen in Table 1.

Table 1. Results of chemical analysis of the soil sampled from several locations for post-mining land in the village of brick industry Potorono Banguntapan

No.	Village	pH	Level*)	C-org	Level	CEC	Level*)
				(%)		cmol(+).kg ⁻¹	
1	Mayungan	6.15	slightly acid	0.45	very low	3.8	very low
2	Mertosanan wetan	6.44	slightly acid	0.30	very low	5.9	low
3	Nglalen	6.72	neutral	0.30	very low	8.9	low
4	Mintoragan	6.56	neutral	0.35	very low	4.4	very low
5	Petet	6.45	slightly acid	0.50	very low	8.9	low
6	Botokan	5.7	slightly acid	0.57	Low	8.1	low
7	Salakan	5	Acid	0.52	very low	21.6	moderate
8	Mertosanan Kulon	4.6	Acid	0.62	Low	10.7	Low
9	Mertosanan Kidul	5.3	acid	0.85	Low	19.4	moderate
10	Balong Lor	5.9	slightly acid	0.11	very low	4.3	very low
11	Balong Kidul	5.9	slightly acid	0.42	very low	18.7	moderate
12	Genengan	5.8	slightly acid	0.36	very low	23.5	moderate

Source : Laboratory analysis (2011); *) according to PPT (1983)

Each plant requires a certain soil pH to be able to grow and develop properly. Beside its direct influence on crop, soil pH is also a factor that determines solubility and availability of nutrients contained in soil. Optimal nutrient availability in soil is at neutral pH of about 5.0 - 7.0. Results of analysis of soil pH in post-mining land in various locations demonstrate values 5.0 to 6.7 and considered as slightly acid to neutral (PPT, 1983) (Table 1). The diversity of soil acidity in Potorono village is caused by volcanic ash as parent material and organic matter content in the soil. However, this factor is not a serious constraint because it is easy to be overcome by adding lime.

Soil organic matter plays an important role in controlling soil fertility. Excavation of upper soil layer (top soil) will leave sub-layer of the soil. The excavation process usually reaches approximately 1 m from original soil surface. The content of organic matter in the soil generally decreased with increasing depth of soil profile. Soil sample analysis showed that organic matter content of the new soil surface layer has 0.11% - 0.85% and considered as very low to low according to PPT (1983) (Table 1). Soil scientists would expect to find different behaviour in different soils at different 'critical' concentrations of SOM, it seems widely believed that a major threshold is 2% soil organic carbon (SOC) (ca. 3.4% SOM), below which potentially serious decline in soil quality will occur (Loveland and Webb, 2003). The three of twelve soil samples have low level of SOC, while another have very low level. This is presumably due to the upper soil layer (top soil) is new also lose their source of organic material that usually comes from the remains of plants that grow on it. Mining land to brick industrial activity remains open pit and overgrown plants, because it is difficult for plant to grow on this place. At some locations, it has been backfilled with organic material in the form of organic waste that is considered as the first step in addressing the problem. Addition of organic matter from the outside and replanting with tolerant crop varieties may produce organic matter to restore soil fertility. Application of organic manure increased accumulation of organic C and N and formation of water-stable aggregates better than the application of chemical fertilizers. (Zhang and Fang, 2007)

The average sand content of the soil profiles increased by 330%, while the silt and clay contents decreased by 49% and 40%, respectively. The average losses arising from the burning of agricultural soils were amounted to 63% for organic matter, 56 to 86 % and 23 to 88 % for available and total N, P, K and S, respectively (Khan et al., 2007). The increment of sand content in the burnt soils was attributed to the addition of more sandy soils materials during brick production which may lead to the reduction of the strength and quality of bricks. The 3/4th loss of organic matter and nutrients in the burnt soils were due to the burning of the agricultural top soils. It is well known that soil organic matter is a reservoir for plant nutrients, enhances water holding capacity, protects soil structure against compaction and erosion, and thus determines soil productivity (Khan et al., 2007).

Soil nutrient availability is needed by plants. Nitrogen (N), phosphorus (P) and potassium (K) are essential nutrient needed by plants in large amounts (macro nutrients). Sufficient amount and balance of nutrients in a determinant factor for as well as the growth and development of crop production. The soil analysis results showed that soil total N content of the post-mining land for brick industry ranged between 0.03 - 0.29% and is included in very low to moderate level (PPT, 1983). Five of 12 soil samples have very low levels. The highest value of total N was found in Mintoragan 0.29%. The loss of topsoil is the main cause of low total N content in new top soil. Upper soil layer (top soil) both natural and native land cultivation is the most fertile part of the soil as it rich in nutrients. This layer is an ideal medium for plants and microorganisms to live in. The loss of organic matter and soil organisms used for brick industry cycles cause destruction of ecosystems and natural elements in the soil.

Phosphorus (P) is needed by plants, especially in the generative of flowering and fruiting phase. Phosphorus deficiencies will result in a decreased yield. The results showed that soil P content for the post-mining land brick industry is widely varied and ranges from 5.6 ppm to 103.7 ppm with very low to very high level (PPT, 1983). Of the

12 soil samples taken, 5 of them are of very high P content and 3 are very low. Land in Mayungan has provided the highest soil P content among other village locations, 103.7 ppm. P has character of slow available element (slow release element) means that the element is not easily soluble while the availability of low potassium include at various locations after mining (Figure 5.) For normal fertile agricultural soil, N, P and K values are 0.5- 1.5 %, 0.01-0.2 % and 0.02-0.2 %, respectively (Allen, 1989). pH of organic soil (normal fertile soil) has a range between 5.5 to 6.8. (Yadav, 2003)

Beside of N and P, K nutrients are also needed by plants. Potassium deficiency will cause plants to be easily collapsed and broken. The analysis showed that the content of available K in soil ranged between 0.19% - 1.53% and it included in low to very high level. In general, available K content of the soil in Potorono is included as high. This is due to the element is bound by soil sorption. Along with the rain water runoff, nutrients to flow into the possible site of a former quarry that implies a relatively high. Indicator of soil ability to retain nutrients is value of cation exchange capacity (CEC). Cation exchange capacity (CEC) is very important because it relates to the ability of soil to bind nutrients in cations form. Therefore it determines level of efficiency in soil fertilizing. Soil analysis results indicate that CEC of soil post-mining for brick industry ranged from 3.8 to 23.5 cmol (+).kg⁻¹ soil and it included in very low to moderate level (PPT, 1983). Cation exchange capacity of soil taken from Mayungan, Mintoragan and Balonglor have very low level (Table 1.) Cation exchange capacity of soil is strongly influenced by soil colloids especially organic matter and clay content. The low of cation exchange capacity in this land was caused clay and organic matter content that is very low. Soil samples from Salakan, Mertosanan Kidul, Balong Kidul, and Genengan have high CEC value, although still included in medium level. This is due to the clay content was relatively higher than soil in other locations.

Both fertilization and tillage improved chemical, biological and physical properties of soils the. Deep tillage significantly decreased soil bulk density and significantly

Table 2. Results of nutrient analysis of soil samples from several locations for post-mining land in the village of brick industry Potorono Banguntapan

No.	Village	N tot (%)	Level	P tsd (ppm)	Level	K tsd (me%)	Level
1	Mayungan	0.19	low	103.72	very high	1.21	very high
2	Mertosanan wetan	0.19	low	97.32	very high	1.53	very high
3	Nglalen	0.14	low	27.87	very high	2.38	very high
4	Mintoragan	0.24	medium	48.31	very high	1.34	very high
5	Petet	0.29	medium	23.78	very high	1.12	very high
6	Botokan	0.05	very low	9.03	very low	0.25	low
7	Salakan	0.05	very low	16.34	medium	0.63	high
8	Mertosanan Kulon	0.05	very low	33.11	high	0.50	medium
9	Mertosanan Kidul	0.07	very low	5.59	very low	0.37	medium
10	Balong Lor	0.01	very low	9.46	very low	0.19	low
11	Balong Kidul	0.04	very low	20.64	medium	0.36	medium
12	Genengan	0.03	very low	13.33	low	0.67	high

Source : Analisis of Laboratory

increased infiltration rate. Use of organic manure and chemical fertilization increased soil nutrients and microbial biomass. Application of organic manure significantly increased levels of organic C and N (Zhang dan Fang. 2007)

CONCLUSION

1. C-organic, total nitrogen and CEC were limiting factors for soil fertility in post-mining soil of brick industry in Potorono village.
2. Amelioration is necessary supplied, especially organic matter to improve soil CEC, as well as improve physical and chemical properties.

ACKNOWLEDGEMENT

We cordially thank The Institute for Research and Community Service, UPN "Veteran" Yogyakarta which was funded this research through Applicative Research scheme.

REFERENCES

- Andriani, E. 2011. Degradasi Lahan . Jurnal Tata guna lahan dan Lanskap <http://tatagunalahandanlandsekap.blogspot.com/>
- Direktorat Jenderal Pengelolaan Lahan dan Air. 2009. Pedoman Teknis Reklamasi Lahan. Departemen Pertanian. Jakarta.
- Hakim, N., M.Y. Nyakpa, A.M. Lubis, S.G. Nugroho, M.R. Saul, M.A. Diha, G.B. Hong, H.H. Bailey. 1988. Dasar-Dasar Ilmu Tanah. Penerbit Universitas Lampung. Lampung
- Hardjowigeno, S. 1992. Ilmu Tanah. P.T. Medyatama Sarana Perkasa. Jakarta
- Hidayat, R., M Indriastuti, F Syafrina, SD Arismawati, B. Sembodo.2009. Model Reklamasi Lahan Kritis Pada Area Bekas Penggalian Batu Bata. *Jurnal Bestari*, Vol 42
- Khan H. R., Rahman, A. J. M. Abdur Rouf, G. S. Sattar ,Y. Oki, T. Adachi. 2007. Assessment of degradation of agricultural soils arising from brick burning in selected soil profiles. *Int. J. Environ. Sci. Tech.*, 4 (4): 471-480, Autumn
- Loveland, P. and J Webb.2003. Is there a critical level of organic matter in the agricultural soils of temperate regions: a review. *Soil and Tillage Research*. Volume 70, Issue 1, March, Pages 1–18
- Mutert. 1995. Summary of Final Discussion. International Seminar on Appropriate Use of Fertilizer. Taiwan ROC.
- Prihtiyani, E. 2010. Industri batu bata mengkhawatirkan : Lahan di Pleret, Banguntapan, dan Piungan rusak. Kompas, Selasa 30 Maret 2010.
- Pusat Penelitian Tanah. 1983. Term of Reference. Survei Kapabilitas Tanah. Proyek Penelitian Pertanian Menunjang Transmigrasi (P3MT) No. 59a/1983

- Rahayu, S. 2011. Upaya rehabilitasi pada lahan sawah bekas penambangan bahan baku batu bata (Desa Sitiadi, Kecamatan Puring, Kabupaten Kebumen). [http://etd.ugm.ac.id/index.php?mod= penelitian_detail&sub= PenelitianDetail &act=view&typ=html&buku_id=37505&obyek_id=4](http://etd.ugm.ac.id/index.php?mod=penelitian_detail&sub=PenelitianDetail&act=view&typ=html&buku_id=37505&obyek_id=4) [4April 2011]
- Singh, N.P. 2001. Impact of Land Degradation (Chapter – III)
<http://dspace.vidyanidhi.org.in:8080/dspace/bitstream/2009/5650./4/DLU-2001-153-3.pdf>
- Suntoro W, A. 2006. Degradasi lahan & ancaman bagi pertanian. SOLO POS, Selasa pon, 7 Nopember 2006.
- Suntoro. W, 2006. Dampak Kegiatan Pembangunan terhadap Degradasi Lahan Pertanian. *Prospect*. Februari, Tahun 2, No.2
- Yadav., S. K. 2003. Remote Sensing Based Management of Degraded Soil Due to Brick Industry for Sustainable Development – A Case Study. *J. Hum. Ecol.*, 14(6): 451-455
- Zhang, M. K., L.-p. Fang. 2007. Effect of tillage, fertilizer and green manure cropping on soil quality at an abandoned brick making site. *Soil & Tillage Research* 88 93 : 87-93

THE POTENTIAL OF GROUNDWATER IN UNCONFINED AQUIFER AT JOGONALAN AREA KLATEN CENTRAL JAVA

Lanjar Sudarto

Agrotechnology Department

Faculty of Agriculture UPN "Veteran" Yogyakarta, Indonesia

e-mail : Lsudar05@Yahoo.com

ABSTRACT

The research aims to describe availability of ground water in the unconfined aquifer (shallow aquifer) for irrigation water requirements. Area of research is located at 7°30'-7°50' South Latitude and 110° 25' -110° 40' East Longitude. Agro-climatic conditions in the study area is C2 class (5-6 dry months and 2-4 wet months). The highest rainfall is at January (360.1 mm/month), annual rainfall is about 1,897mm/years. The area is potential for agricultural development for rice productions in Klaten, Central Java. Nevertheless there is problem of water deficit in the dry season during April to September. As an effort to resolve the water deficit problem, the farmers conduct to drilling shallow water wells (range of depth 20-30m). Usually, in the dry season groundwater pumping is exceed for irrigation water supplied. Pumping discharges is about 3 to 5 lt/sec. Each well could irrigate areas about 1.5 to 2.0 ha. Over-pumping of the groundwater might change the water balances of groundwater storages and water recharges. In the area will be a decrease of the groundwater levels. Decrease drawdown water levels would disrupt the community, because the groundwater also required by the community for drinking water.

Keywords : groundwater, unconfined aquifer, irrigation

INTRODUCTION

Water is a natural resource which is very important, because water becoming increasingly a rare. The presence of water should be maintained in order to fit the future availability and sufficiency. Water requirements will increase in accordance with the development of physical and social areas. Therefore, research related to the water resources should be done in an integrated and sustained manner. In the research area, it has been evidenced several activities of shallow groundwater pumping for irrigation to meet the water needs. Groundwater pumping is carried out both in the rainy season and the dry season. This was due to surface water is not sufficient for irrigation water in the both season.

Actually, the research area has been targeted for the development of irrigation wells pump in Klaten regency. The activity was concentrated in 2 districts, those are Jogonalan and Prambanan. In these both areas it was constructed 18 wells pumping by the provincial government of Central Java. Efforts to supply irrigation water

requirement, the farmers in this area do alternative with pumping unconfined groundwater on shallow wells in the paddy fields. With reason, if the water required for irrigation pumping can be pumping with the appropriate volume of water supply and the cost owned.

Unconfined groundwater wells used by farmers with constructed wells drilled in the shallow aquifer at range of depths about 10 m from surface. Unconfined groundwater in this area is pumping to supply of water requirement. Groundwater pumping for irrigation with large discharge will be decreasing water levels of groundwater. Decrease groundwater levels has caused water supply problems, especially during the dry season. The local peoples having water supply problems because dug well water is lost.

The research will describe unconfined groundwater availability in the area, before drawdown groundwater level problems in order, to prevent the loss of well water. The supply of groundwater for irrigation can be controlled according to the availability of groundwater potential. These results can be considered as water used in unconfined aquifer for irrigation. Unconfined groundwater pumping for irrigation exceeds the capacity availability. There is no problem with the availability of fresh water in shallow wells used by local people in the area.

MATERIAL AND METHODS

The equipment used to measure of the ground water levels is the electric probe (electric water level). It consists of a cable that given an appropriate depth scale. The tip of the electrode cable were touched when the contact surface of the water will cause electricity connected. The top of the rolls were assembled with light with batteries or ammeter / voltmeter. This equipment used to for measuring the depth of water levels.

Data of discharge pumping required for determine the volume of water flowed from the discharge pumping is done. Each section has aquifer characteristics and the characteristics of the different wells, will be determine the volume of water contained. Description of the thickness aquifer and characteristics of the aquifer lithology are to estimate the potential groundwater.

Estimation of potential groundwater based on the volume of water flowing from the shallow groundwater flow in the aquifer is horizontal. To calculate of discharges the shallow groundwater flow using the basic formula

$$Q = T \times I \times L$$

Description:

Q = discharge of groundwater

T = transmissivity

I = the slope hydraulics

L = sectional area of the aquifer

RESULTS AND DISCUSSION

The research area is at Jogonalan subdistrict, Klaten regency, Central Java. The geographic location is in the position of 7°30' -7°50' South Latitude and 110°25' - 110°40' East Longitude, with boundaries as follows :

- North is bordered to the territory of Manisrenggo
- East is bordered to the Gondang River, District Kebonarum
- West is bordered to Pandansimping River District Jogonalan
- South is bordered to a region of Wedi

A. Effective rainfall

The research area is a tropical climate with two seasons. Number of dry months (dry season) varies between 2-4 months, while the wet months (rainy season) between 5-6 months. According to data acquired from the rainfall station are the average rainfall approximately 1.897 mm / yr. The highest is 360.1 mm, at January.

Effective rainfall is the total rainfall that directly to supplywater requirements for crops (Partowijoto, 1999). These area with sloping topography moderate, irrigation water supply to the fields is generally done from the channel to the field in the upper plot of land and after getting enough water, then the water overflow into the lower reaches.

The water used from land runoff to the downstream embankment of digging at the plot on a certain elevation so that runoff occurs automatically when the desired pool of above has been achieved. At little discharge conditions of the upstream rice fields are still obtain sufficient water supply. For land of the lower reaches of the drainage water getting supply from the upper reaches. It is adjusted of types crops planted.

Effectiveness of rainfall will increase if the rotational interval is longer, but the rotation interval is limited by the number of days in the land where the plant before it reaches the wilting point (usually done every 10-12 days).

B. Evapotranspiration

Evapotranspiration is the process by which a liquid or solid is charged into vapor. Liquid moves from surface of the land, surface water, and crop into the air. Factors that influence the evapotranspiration is the water temperature, temperatures, humidity, winds speed, barometric pressure, sunlight and others are related to each other.

Potential evapotranspiration (Eto) -may be defined as the evapo-transpirations that would occur where there an adequate moisture supply at all time. There is the amount of water transpired in unit time by the plant as a whole covering the ground with a uniform elevation, no shortage of water supply, and are not attacked by pests and diseases. By another definition, Eto is defined as the volume of water used by the crop is affected by climatological factors, which consists of evaporation and transpiration. Both of these processes (evaporation and transpiration) affect each other so defined as evapotranspiration. Evaporation occurs at the condition of the land there is enough water to supply crop with optimum -defined is potential evaporation (Eto). Based on calculation, Eto in the study area ranged from 51.07 -up to 59.5 mm per 15 daily, in August at the second week.

C. Unconfined Aquifer

Aquifer lithology often called -as water storage layer, is the lithologic layers that have space between the grains with water can be stored and streamed on the condition of the field capacity. Terms of water storage layer, the composition of the material must have such a way that is accommodating and able to absorb rain water through a pore or

fracture. These aquifers have volume large and thick as underground water storage. Existing groundwater in the aquifer will flow horizontally because of differences with hydraulic conductivity. This is defined as the hydraulic gradient. The velocity of the groundwater flow is from a few centimeters to hundreds meters per day. So that the water contained in the layers held enough before reaching the discharge.

Based on the composition of litology, aquifers would be described as unconfined aquifer. Water storage layer is characterized by groundwater level (water table) is the upper boundary of a layer of impermeable. The water pressure is equal to atmospheric pressure. Configuration of the groundwater elevation contours and forms of the groundwater table and will be determined from the height of the water in the wells. The determination of storage of water is calculated based on the volume of water flow, distribution and direction of flow.

D. Groundwater level

Groundwater level is the groundwater level measurements in wells drilled in the area and calculated with the sea level (asl). Description of ground water level, in the northern location area is 178.00 (m, asl), based on the well data No. 119.; Gradually to the south area (based on measurements of wells No.85). Groundwater level elevation 130.88 (m, asl); Description groundwater water levels in these area can be viewed in Table 1.

Table 1. Elevation groundwater levels in the research area

No.	Pump location	Coordinates (X) (m)	Coordinates (Y) (m)	Elevation (m, asl)	Posisitins Water levels (m)	Elevations Water levels (m, asl)
1	Somopuro	448800	9143300	148,77	1,77	147,00
2	Dompyongan	448200	9146600	181,54	2,54	179,00
3	Rejoso	450600	9144300	140,76	1,76	139,00
4	Titang	449800	9143900	145,90	1,90	144,00
5	Muruh	447900	9144100	140,48	1,98	138,50
6	Prawatan	448900	9144600	178,48	3,98	174,50
7	Perawatan	449900	9144700	188,20	5,20	183,00
8	Joton	446100	9144500	201,28	10,78	190,50
9	Randusari	446200	9145600	185,09	7,09	178,00
10	Brajan	447500	9144800	166,55	4,55	162,00
11	Kemudo	446800	9142200	147,22	2,72	144,50
12	Geneng	447500	9143600	154,33	2,33	152,00
13	Muruh	446800	9142700	146,55	2,05	144,50
14	Kraguman	450500	9146900	176,60	3,10	173,50
15	Kraguman	447900	9146700	178,15	4,65	173,50
16	Dompyongan	447900	9146900	187,65	5,85	181,80
17	Dompyongan	448300	9145900	175,10	4,60	170,50
18	Joton	449100	9147100	185,10	4,00	181,10
19	Wonoboyo	448700	9145500	168,21	3,21	165,00
20	Somopuro	448800	9144900	162,81	4,06	158,70
21	Kraguman	451100	9147500	184,88	6,08	178,80
22	Gondongan	450500	9147400	162,99	5,99	157,00
23	Rejoso	449900	9144000	151,20	4,70	146,50

Based on the groundwater level will be described groundwater level contours with the conditions -aquifer assumption is homogeneous and isotropic; hence groundwater flow direction is perpendicular to the equipotentials. The aquifer thickness and locations distribution in the area would be calculated groundwater flow volumes. To simplify of the volume of ground water flow is dividing the area into a number of segments of groundwater flow. Results of groundwater flow in the area are as shown in Table 2.

The maximum discharge of pumping is observed from pumping test wells at the time. Water available at the pump well is illustrated from the groundwater level elevation. The data needed to determine the volume water discharge from the pumping is done. In areas that aquifer characteristics and wells different, it will show -different of discharge and groundwater levels. Aquifer thickness of the layers and lithology profiles are used to estimate the potential for groundwater flow.

Table 2. The calculations of groundwater flow in the study areas

No	Segmens of flow	Volume GW flows (m3/day)
1	I. The western flows	2,581.30
2	II. The middle flows	2,691.73
3	III. The east flows	3,245.40
	Of the study area	
	Volume of GW flows	8,426.43

To determine the groundwater potential is done by pumping discharge. If the average discharge pumping is done than the maximum allowable discharge ranged from 1.10 times. Based on pumping, it is necessary to discharge the magnitude of reduction, in order to avoid decreased water level. The consequence will result in the operation hours of pumping will increase the provision of irrigation water per unit area.

CONCLUSION

Evaptranspiration potential rate (Eto) is 51.07 to 59.5 mm per 15 daily, and the highest rate is in August. Based on the effective rainfall and irrigation water requirement, there are no irrigation water supply required from December to April. Irrigation water supply is required only from April to mid November. Water requirement is highest, in May-September and October, because of supply water for land preparation and tillage. The water requirement can be reduced by the effective rainfall.

REFERENCES

- Ankum, P., 1989. Irrigation Water Requirement: at field, tertiary and main system level. International Institute for Hydraulic and Environmental Engineering. Delft, The Neherlands.
- Dirjen Pengairan, 1986. Standar Perencanaan Irigasi (KP. 01-05). Direktorat Jenderal Pengairan, Departemen Pekerjaan Umum, CV. Galang Persada, Bandung.
- Doorenbos, J. and W.O. Pruitt., 1984. Crop Water Requirements. FAO. Irrigation and Drainage Paper no.24, Rome.

- Partowijoto, A., 1999. Peningkatan Efisiensi dan Efektifitas Dalam Pengelolaan Air Irigasi Oleh Masyarakat : Kendala Teknis dan Non Teknis. Prosiding Seminar Sehari Peningkatan Pendapatan dan Kesejahteraan Petani Melalui Pendekatan Partisipasi, IESC-RCA - FT UGM, Yogyakarta
- Sudarto, L.,2010. Ketersediaan Air Tanah Untuk Irigasi Di Daerah Jogonalan – Klaten. Laporan Penelitian. Fakultas Pertanian, Universitas Pembangunan Nasional “Veteran” Yogyakarta.
- Sudarto, L, 2000. Tinjauan Debit Maksimum Pemompaan Pada Pengembangan Irigasi Pompa di Daerah Klaten. Di dalam Prosiding Seminar Teknologi Pertanian Spesifik Lokasi Dalam Upaya Peningkatan Kesejahteraan Petani dan Pelestarian Lingkungan, Yogyakarta 2 Desember 1999. hlm 149-154.

DETERMINATION OF DEPTH GROUNDWATER LEVELS BASED ON GEOPHYSICAL WITH GEOELECTRIC METHOD AROUND THE PRAMBANAN TEMPLE REGION YOGYAKARTA PROVINCE

Agus Santoso¹, Sismanto², Ari Setiawan², Subagyo³

¹Geophysical engineering UPN "Veteran" Yogyakarta,

²FMIPA Gajahmada University

²FMIPA Gajahmada University

³Geology Engineering, Gajahmada University

email : geof_upn@yahoo.com

ABSTRACT.

Geoelectric is one geophysical method that aims to identify formations that are conducive in the earth, The purpose of this study is to describe geology configurations beneath the surface resistivity is lower in areas containing groundwater potential is estimated. At Schlumberger resistivity methods in electrical current injected into the earth through the current electrodes, then the potential difference that arises in measuring via two electrode potential. From these measurements for different electrode spacing will then be obtained resistivity variations in rates of each layer below the measuring point. The goal is to obtain information about the depth and thickness of rock layers vertically resistivity rates, in order to get a complete picture of the geology below the surface. The difference in resistivity will be evident in the depth determination of rock layers that have different types of resistivity.

Keywords: geoelectric, schlumberger, ohm-m, groundwater.

INTRODUCTION.

Geoelectric is a geophysical method that studies the nature of the flow of electricity in the earth and how to detect the earth's surface. In this case includes potential measurements, currents and electromagnetic fields that occur, either naturally or due to current injection into the earth. Therefore geoelectric method has many kinds, including the self-potential method, teluric current, magneto teluric, electro-magnetic, induced polarization and resistivity methods. In the resistivity method in the injected electric current into the earth electrode meialui flow, then the potential difference that arises in measuring via two electrode potential. From these measurements for different electrode spacing can then be reduced resistivity variations in rates of each layer below the measuring point..

A. Basic Theory

The basic principle of geoelectric resistivity method is Ohm's Law. Where the resistance is obtained by measuring the potential difference and current in a conductor is passed.

$$R = V/I \dots\dots\dots (1)$$

where R is the resistance (resistance) in units of ohms, V potential difference and I is the current passed Ampere. Because of the medium under the surface of the Earth is not homogeneous (similar), then there is a sense of resistance type (resistivity), which depends on the current and potential electrode installation or configuration factor (k), in addition to the read voltage (V) and currents are transmitted (I).

$$\text{Rho} = V/I \dots\dots\dots (2)$$

Where Rho is an Apparent resistivity value.

Implementation of the resistivity method is to send the current and potential measures, with current and potential electrode spacing were varied. Thus, the price obtained resistivity or for any distance electrode current and potential certain amount.

With the data plotting resistivity against electrode spacing flows, it is obtained the curve that describes the functional relationship between the current electrode spacing (space) and resistivity.

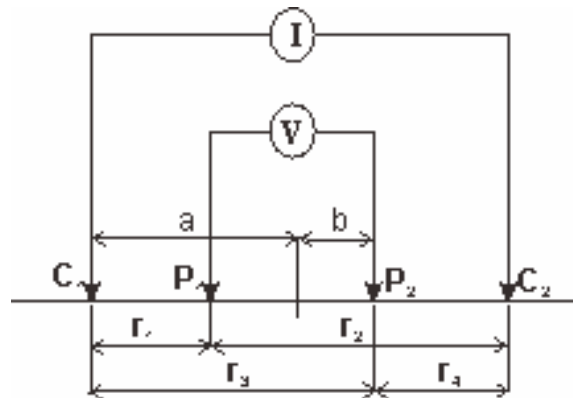

Fig. 1. Geoelectric Schlumberger arrangement

Shlumberger electrode array configurations factors can be found from the general equation k, by entering the value spasing :

$$C_1P_1 = (a-b) \quad ; \quad C_1P_2 = (a+b)$$

$$C_2P_1 = (a+b) \quad ; \quad C_2P_2 = (a-b)$$

$$k_s = 2\pi \left[\frac{1}{a-b} - \frac{1}{a+b} - \frac{1}{a+b} + \frac{1}{a-b} \right]^{-1}$$

$$k_s = 2\pi \left[2 \left(\frac{a+b-(a-b)}{a^2-b^2} \right) \right]^{-1}$$

$$k_s = \pi \frac{(a^2 - b^2)}{2b}$$

B. Geoelectric Equipment

The equipment used in this geoelectric

Investigation are :

1. ARES digital resistivity meter
2. Cable 4 rolls with a length of over 300 m
3. Two current electrodes and 2 (two) potential electrode
4. 12 volt batteries and some dry battery type
5. GPS (Global Positioning System)
6. Compass geology and geological hammer
7. The meter and multimeter as well as topographic maps scale 1: 5000.

C. Data Aquisition.

Geoelectric field measurements using the Schlumberger method, with the Vertical Electrical Sounding (VES). Working Principle: Two potential electrodes fixed distance while the two current electrodes changed

Current electrodes (C1 and C2) were placed on the outside and the potential electrodes (P1 and P2) placed next to. Each measurement point spacing (distance) of the electrode arrangement gradually enlarged the distance, the maximum distance of the electrode currents: 300 m.

Prices are measured in the field is apparent resistivity prices, which need to be analyzed by the method of curvilinear equation, using the standard curve.

In this investigation the data were recorded and measured in the field are:

Note: No Location, Location azimuth and Geography. measured: The range of current electrodes, Spanning electrode potential, current flow, and apparent resistivity (ohm-m). The tools used in this measurement readings digitally, which can determine the course of the injected current, so it can be seen when the current flow is interrupted.

D. General Geology.

1. Geomorphology.

In general, the measurement area is located in the plains of measurement generally located in the tourist area of Prambanan temple with lush vegetation and berelief pretty much flat. Topography of the area is caused by the eruption of Mount Merapi

..

2. Lithology (rock Composer)

Lithology or rock-forming regions are Breccia, sandstone and clay. volcanic breccia rocks are widespread throughout Sleman, with andesite fragments 5-50 cm, matrix of silica sand and cement, the water is generally difficult. Genesis of these rocks originated from the eruption of Mount Merapi volcanic products younger Pliocene age .. Some sandstone aquifer located on inserts or sandy breccia or fracture porosity in the breccia voklanik large enough to be aquifers. The thick inserts 2-30 cm.

E Data Processing

**Rock Resistivity Vs Depth Chart
Location-01 : Prambanan Temple (East)**

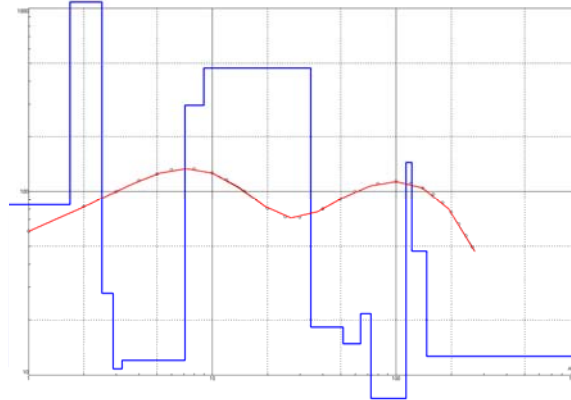

Prambanan – 01

No	Depth (m)	RESISTIVITY (Ohm-m)	ROCK COMPOSITION
1	0 – 1,6	85	Soil
2	1,6 – 2,5	989	Andesitic Breccia
3	2,5 – 3	28	Sandstone
4	3 – 4	11	Clay
5	4 – 7	12	Clay
6	7 – 9	297	Andesitic Breccia
7	9 – 34	471	Andesitic Breccia
8	34 – 51	19	Sandy clay
9	51 – 65	15	Sandy clay
10	65 – 75	22	Sandstone (Aquifer)
11	75 – 113	0,2	Clay
12	113 – 122	143	Sandy Breccia
13	122 – 147	46	Sandstone (Aquifer)
14	> 147	12	Clay

**Rock Resistivity Vs Depth Chart
Location-02 : Prambanan Temple (Centre)**

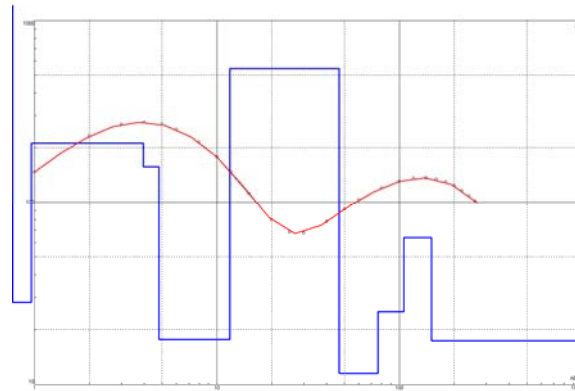

Prambanan – 02

No	Depth (m)	RESISTIVITY (Ohm-m)	ROCK COMPOSITION
1	0 – 0,9	28	Soil
2	0,9 – 4	212	Andesitic Breccia
3	4 – 5	157	Sandy Breccia
4	5 – 12	17	Sandi clay
5	12 – 47	547	Andesitic Breccia
6	47 – 76	12	Clay
7	76 – 106	25	Sandstone (Aquifer)
8	106 – 150	64	Coarse sand
9	> 150	17	Sandy Clay

Rock Resistivity Vs Depth Chart

Location-03 : Prambanan Temple (West)

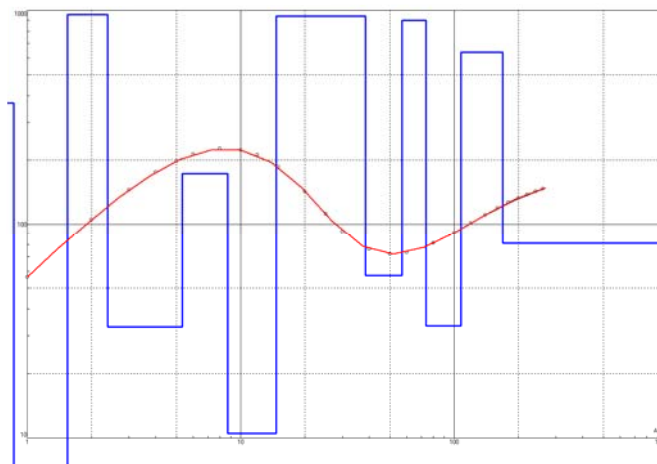

Prambanan – 03

No	Depth (m)	RESISTIVIT Y (Ohm-m)	ROCK COMPOSITION
1	0 – 0,8	368	Soil
2	0,8 – 1,5	3	Clay

3	1,5 – 2,3	956	Andesitic Breccia
4	2,3 – 5	33	Sandstone
5	5 – 9	172	Sandy Breccia
6	9 – 14	11	Clay
7	14 – 38	938	Andesitic Breccia
8	38 – 57	57	Coarse Sand
9	57 – 74	898	Andesitic Breccia

F. Interpretation

Based on the results of the final analysis sounding (Schlumberger method) were performed with a computer program, and also with the curve matching and supported local and regional geological data area of research, the final result is obtained: the depth of the resistivity correlates with the magnitude of the real ("True resistivity") of rock is divided into a number of rock units as follows:

1. Soil

Resistivitynya range from 28 to more than 386 Ohm meters, consisting of loose sand, clay, silt, gravel and gravel

2. Clay Unit

Resistivity less than 10 ohm - meters, consists of clay. Generally very Impermeable.

3. Unit of sandy clay or sand clay

Resistivity between 10-20 ohm - meter, sometimes dominant rock with a mixture of sand or clay marl or inserts both, which is somewhat permeable, generally watery but not so large debits.

4. Sandstone unit (Sandstone)

Resistivity 20-50 ohm-m, which generally is comprised sandstone sediment volcanic lava flow from the eruption. Aquifer is good, very permeable and contain enough water to discharge.

5. Coarse sand unit

Resistivity 50-100 ohm-meter, with a mixture of sand rock breccia with andesite fragments the size of 5-10 mm, matrix of sand, cement silica.

6. Sandy breccia unit

Resistivity 100-200 ohm-meters. Sometimes less compact with a size of 5-10 cm andesite fragments, matrix of sand, cement and silica.

7. Breccia Unit

Resistivity 200 - 1000 ohm-m. Fragments of andesitic volcanics 5 -50 cm, matrix of silica sand and cement

8. Lava Unit

Resistivity > 1000 ohm-m consists of Lava (1000-5000 ohm-m).
Correlation Between Geoelectric point (point 01, 02, 03).

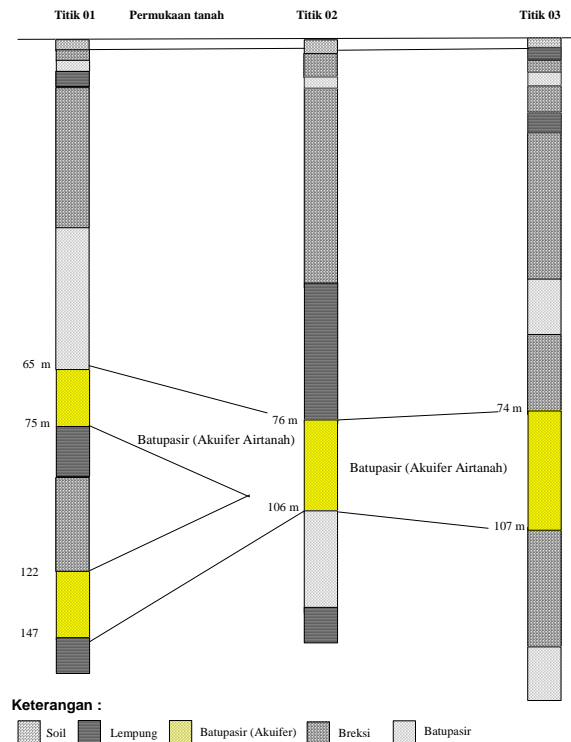

CONCLUSION

1. Soil resistivity from 1.5 to 101 Ohm m, loose sand, clay, gravel
 - Clay resistivity <10 ohm - m, clay. very Impermeable.
 - Sandy clay or sand clay: 10-20 ohm - m, -
 - Sandstones: 20-50 ohm-m, sandstone, good aquifer, discharge quite a lot.
 - Coarse sand 50-100 ohm-m, and Resisitivitas > 200 ohm-m is coarse sand.

2.Point 01: Aquifer groundwater at a depth of 65-75 mtr, 7 m thick aquifer. The second aquifer at a depth of 122-147 m, thickness of 10 meters.

Point 02: Aquifer groundwater at depths of 76-106 m, 25 m thick aquifer.

Point 03: Aquifer groundwater at depths of 74-107 m, 30 m thick aquifer.

3. Debit estimates by a wide rock aquifers is a gap in the sandstone aquifer and the breccia is 1-3 liters / sec.

REFERENCES

- Cas, R.A.F., dan Wright, J.V., 1987. *Volcanic Succession: Modern and Ancient*, Allen & Unwin, London, 534 h.
- Dobrin, M,B & Savit, CH 1988, "*Introduction to Geophysical Prospecting*", Mc Graw Hill Co, Fourth edition, New York, San Fransisco.

- Grant, F.S. & West, G.F., 1965, "*Interpretation Theory in Applied Geophysics*", McGraw Hill Co, New York, San Francisco, Toronto, London, Sydney.
- Hartono, G. dan Syafri, I., 2007. Peranan Merapi Untuk Mengidentifikasi Fosil Gunung Api Pada "F. Andesit Tua"
- Keller, G.V. and Frischkenect, F.C., 1970, "Electrical Methods in Geophysical Prospecting", pp 17 - 166, Pergamont Press, New York.
- Macdonald, A.G., 1972. *Volcanoes*. Prentice-Hall, Inc. Englewood Cliffs, New Jersey, 510 h.
- Rahardjo, W., Sukandarrumidi dan Rosidi, H. M. D., 1977. *Peta Geologi Lembar Jogjakarta, Jawa, skala 1 : 100.000*. Puslitbang Geologi, Bandung.
- Telford, W.M, Geldart, L.P, Sheriff, R.E & Keys, D.A, 1976, "*Applied Geophysics*" Cambridge University Press, New York, London Melbourne.
- Van Bemmelen, R.W., 1949. *The Geology of Indonesia*, Vol IA. Government Printing Office, The Hague, 732 h.

We wish to thank support and sponsors for their contribution in making this Conference possible.

1. Faculty of Agriculture UPN “Veteran” Yogyakarta
2. PT Sido Muncul , Semarang
3. SG Computer, Yogyakarta
4. Mrs. Mursupriyani
5. Mr. Ir. Eddy Martono R, MM
6. ARBAS AMDK, Sleman Yogyakarta

ISBN 978-979-18768-3-4



9 789791 876834