

NEW METHOD OF CRITERIA WEIGHTING FOR SUPPLIER SELECTION

by Ristono Agus

Submission date: 25-Aug-2020 10:00PM (UTC+0700)

Submission ID: 1373901992

File name: article_42.pdf (1.97M)

Word count: 10679

Character count: 42752

DOI 10.18551/rjoas.2019-03.42

NEW METHOD OF CRITERIA WEIGHTING FOR SUPPLIER SELECTION

Ristono Agus

UPN Veteran Yogyakarta, Indonesia

E-mail: agus.ristono@upnyk.ac.id

ABSTRACT

In the future, researchers focusing on supplier selection are likely to use a combination of multi-criteria decision-making (MCDM) methods. The analytical hierarchy process (AHP) is often used in such combinations. The function of the AHP method in MCDM is criteria weighting. When there are a relatively large number of participants involved in an evaluation judgment, it is difficult to obtain consistent opinions. In such cases, the AHP is a useful method to obtain consistent opinions over time by repeatedly conducting pairwise comparison matrices. This study proposes a new methodology to resolve such problems. In the proposed method, the decision maker assesses the level of contribution of each criterion to the selection of suppliers. Using the proposed method, comparing the contributions of these criteria to supplier selection will always produce a consistent value. The advantage of the proposed method is that decision makers do not have to assess the degree of importance of each individual criterion. So, if there are n criteria, the decision maker has to access as much as n times. The results of this study indicate that the proposed method consistently produces a solution, without the need for repeated human judgements and without consideration of the number of criteria.

KEY WORDS

Analytic hierarchy process, comparison matrix, criteria, consistency ratio, AHP weighting.

In the selection of suppliers, companies generally have various criteria to consider. Usually, if one criterion is considered more important than other criteria, then this criterion is given greater weight. Problems arise when a supplier has to be selected based on a number of criteria [1]. In the future, researchers in the supplier selection field are likely to use a combination of methods of MCDM [2, 3]. One MCDM method that is often used in such combinations is the analytic hierarchy process (AHP) [4, 5]. Therefore, the success of the combination method is determined by AHP weighting [6].

AHP weighting can be considered valid (i.e., to have produced a consistent solution) if the consistency ratio is less than 0.1 [7, 8]. The validity of AHP weighting is determined based on the consistency of the resulting pairwise comparison matrix [9]. In such cases, the ranking or weighting of criteria is based on the judgement of the decision maker [10]. The decision maker has to do (repeat) until the pairwise comparison matrix is consistent. Therefore, the role of human judgment of decision makers is very important in supplier selection using the AHP method.

As the number of criteria increases, human judgments become increasingly sensitive and may become inconsistent [7]. It may be difficult to obtain consistent results when the size of the matrix is relatively large [11] or when there are more than seven criteria [12]. According to the literature, the optimum number of criteria is seven or fewer [13]. Thus, most supplier selection studies use the hierarchical method when there are multiple criteria [14]. However, the latter cannot guarantee consistent results, mainly due to inconsistency in human judgment. To address the aforementioned issues, this study proposes a new method to aid human judgment and ensure consistent decision making. The basic idea underpinning the proposed method is that decision makers are not required to draw comparisons between criteria. As noted above, the higher the number of criteria, the greater the risk of confusion among decision makers.

MATERIALS AND METHODS OF RESEARCH

Much research has focused on overcoming inconsistencies of pairwise comparison matrices using the AHP method. The simplest and most widely performed method involves the use of hierarchical criteria (i.e., AHP criteria weighting), in which criteria are separated into different groups [15-17]. The weakness of the hierarchical method is the extended calculation time the absence of any guarantee of consistency if the number of major criteria or sub-criteria exceeds seven.

Besides the hierarchical method, researchers have described other methods to overcome inconsistencies of pairwise comparison matrices [18, 19]. The crisp value of each criterion is included in the pairwise comparison matrix using Eq (1). In Eq (1), if the L_p and L_q values are equal, then the element a_{ij} in the pairwise comparison matrix is 1. L_q and L_p represent the value of the importance of criteria q and p . If the value of L_p is greater than that of L_q , then the element a_{ij} in the pairwise comparison matrix is $L_p - L_q + 1$. If the value of L_p is smaller than that that of L_q , then the element a_{ij} in the pairwise comparison matrix is $1/(L_p - L_q + 1)$. Inconsistency often occurs because the interval of the comparison value between the criteria is very large. Using equation ($L_p - L_q + 1$), the pairwise comparison matrix will be consistent.

$$a_{ij} = \begin{cases} 1, & \text{if } L_p = L_q \\ L_p - L_q + 1, & \text{if } (L_p - L_q) > 0 \\ \frac{1}{L_p - L_q + 1}, & \text{if } (L_p - L_q) < 0 \end{cases} \quad (1)$$

Table 1 shows a comparison of the scales of Saaty [8] and Li et al. [19]. Replacing the crisp values (1, 3, 5, 7, and 9) with decimal numbers and the reverse comparison, in which $r_{ij}=1/ r_{ji}$ with $r_{ji}=1-r_{ij}$, is expected to minimize inconsistencies. Disadvantages of the modified scale of Li et al. [19] is not produces accurate results.

Table 1 – Importance scale of Saaty [8] and Li et al. [19]

Scale [8]	Scale [19]	Value	Definition
1	0.5	Equally important	Criterion i and criterion j are equally important
3	0.6	Moderately more important	Criterion i is moderately more important than criterion j
5	0.7	Strongly more important	Criterion i is much more important than than criterion j
7	0.8	Very strongly more important	Criterion i is very much more important than than criterion j
9	0.9	Extremely more important	Criterion i is extremely more important than criterion j
1/3; 1/5; 1/7; 1/9	0.1; 0.2; 0.3; 0.4	Reverse comparison	If criterion a_i is compared with criteria a_j and a judgment matrix r_{ij} is obtained, then the judgement matrix of a_j and a_i is as follows: <ul style="list-style-type: none"> • $r_{ji}=1/r_{ij}$ ([8]) • $r_{ji}=1 - r_{ij}$ ([19])

The consistency ratio in AHP is obtained first by calculating the eigenvalue maximum [20]. The consistency index is obtained by nine stages in Figure 1. Figure 1 shows the stages of the AHP. More details on the process can be found elsewhere [8, 21].

In Figure 1, a_{ij} denote the importance assigned to different criteria (i and j), n is the number of criteria, W_i indicates the relative weight of criterion i . CI is the consistency index, and CR is the consistency ratio. The CR is a probability measure that the matrix is filled randomly. Thus, the CR value is the ratio between the current matrix and question and answer matrix [22]. For example, a_{12} denotes the importance of criteria C_1 as compared with that of C_2 . This matrix aims to determine the relative importance levels of supplier selection criteria. Matrix N_{ij} contains normalized a_{ij} values. The data from this matrix is as an input into a relative weight matrix. The content of matrix W_i is the result of calculating the relative

weights of each criterion. In terms of the value W_i , the greater the value assigned to the weight of a criterion, the more this criterion is prioritized by the decision maker. The evaluation matrix E_{ij} and sum matrix V_i are the first two stages in obtaining the CI. To generate an evaluation matrix, E_{ij} , each element in matrix a_{ij} is divided by the weight of the criteria w_i . To obtain the sum matrix V_i , the elements of the evaluation matrix E_{ij} that are in the same row are summed. The consistency index can be obtained after calculating the eigen vector. The eigen vector is the weight of each element used for prioritizing elements at the lowest hierarchy level. After determining the consistency of the index, the results are compared using a random consistency index for each n criterion. To ensure the validity of decision making, the consistency ratio should be $\leq 10\%$ [22].

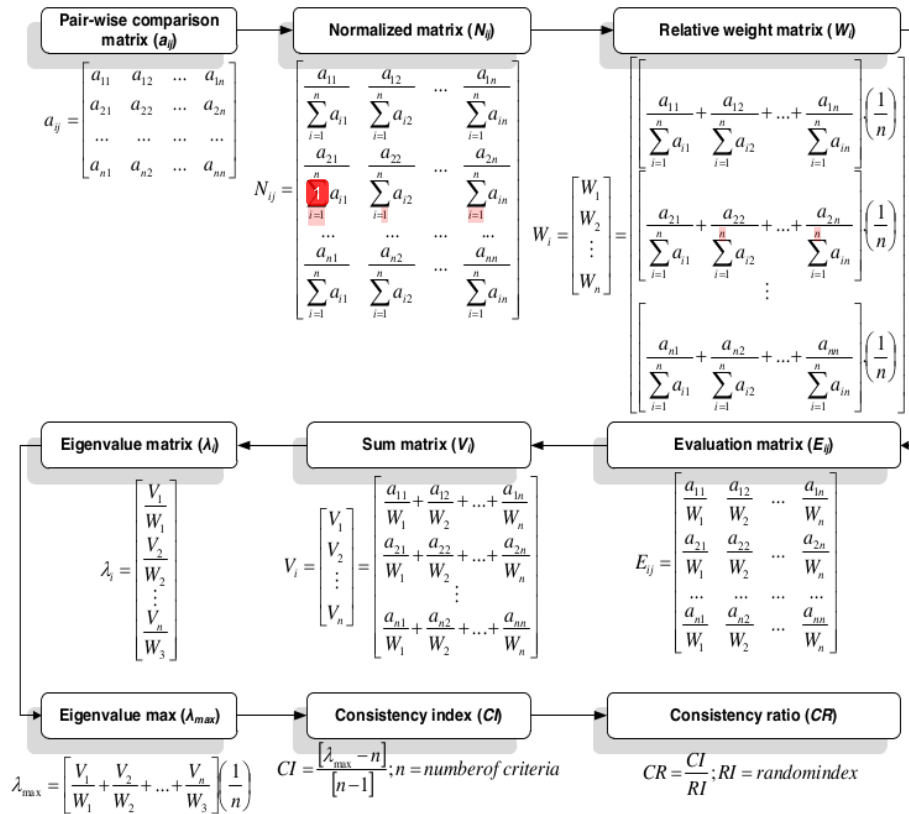

Figure 1 – The stages of the AHP

If a decision maker considers criterion C_2 to be highly important than criterion C_1 and criterion C_3 to be highly important than criterion C_2 then criterion C_3 to be highly important than criterion C_1 . If $C_2 > C_1$ and $C_3 > C_2$, then $C_3 > C_1$. Thus, $C_3 < C_1$ is not possible. As shown in Appendix 1, using only three criteria, AHP will always yield an inconsistent value if pair-wise comparison matrix is inconsistent in the comparison of supplier selection criteria. Essentially, the higher the number of criteria, the higher the inconsistency. This problem can be resolved by assigning importance value to the determination of criteria. If each criterion has a fixed value, then the value assigned to the supplier selection criteria will always be fixed and consistent. If these conditions are met, then the results will always be consistent, regardless of the number of criteria.

In the proposed method, decision makers are asked to assess the level of importance (contribution) of particular criteria to supplier selection. Based on the assessment of the decision maker, supplier selection is adjusted to the level of the contribution of each criterion.

Table 2 shows the contribution values and importance assigned to various criteria in supplier selection. Comparison of the criterion values of the decision maker results in a pairwise comparison matrix. The difference between the original AHP and the proposed method is illustrated in Figure 2. The stages of the generation of the pairwise comparison matrix using the proposed method are shown in Figure 3.

Table 2 – Values and importance assigned to various supplier selection criteria

Contribution level	Definition
1	Weakly or slightly important
2	Important
3	Moderately important
4	Very moderately important
5	Highly important
6	Very highly important
7	Very very highly important
8	Extremely important
9	Very extremely important

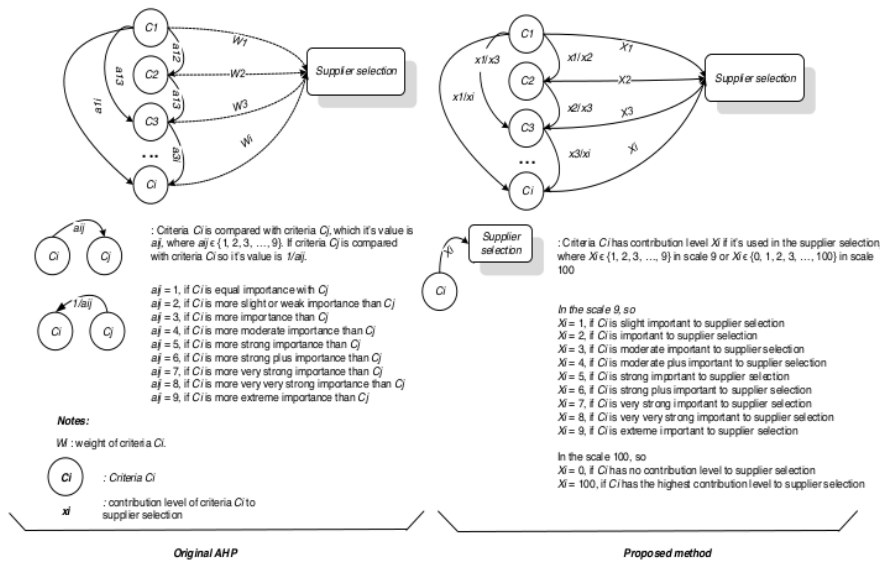

Figure 2 – Basic idea of the proposed method

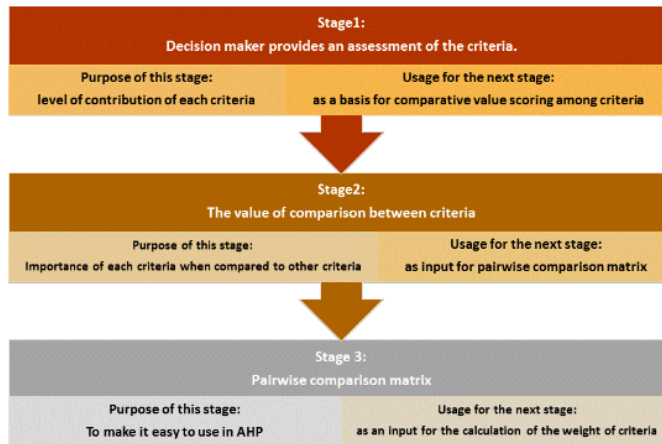

Figure 3 – Stages of the proposed method

The difference between the proposed model and the original AHP lies in the process of generating the pairwise comparison matrix. In the original AHP, decision makers are required to compare one criterion against another. The results of each comparison are then included in the pairwise comparison matrix. This matrix is not necessarily consistent. In the proposed model, the decision maker assigns the level of importance (contribution value) of each criterion in supplier selection. Based on these values, a matrix pairwise comparison is generated.

DISCUSSION OF RESULTS

The performance of the proposed method. We assumed that there were nine criteria ($C_1, C_2, C_3, \dots, C_9$), where the level of contribution was $x_1, x_2, x_3, \dots, x_9$ and $x_i \in \{1, 2, 3, \dots, 9\}$. Based on a comparison of the criteria, C_1 and C_2 were assigned a value of 1 and 2, respectively. Criteria C_2 and C_1 were assigned a value of 2. The values of the comparisons among the other criteria were obtained using the same calculation. Furthermore, we calculated the weight of each criterion and its consistency ratio. The results of the weight calculation and the consistency ratio, as well as the pairwise comparison matrix, are presented in Table 3.

Table 3 – Performance of the proposed method using successive levels

Criteria	C_1	C_2	C_3	C_4	C_5	C_6	C_7	C_8	C_9
C_1	1.00	0.50	0.33	0.25	0.20	0.17	0.14	0.13	0.11
C_2	2.00	1.00	0.67	0.50	0.40	0.33	0.29	0.25	0.22
C_3	3.00	1.50	1.00	0.75	0.60	0.50	0.43	0.38	0.33
C_4	4.00	2.00	1.33	1.00	0.80	0.67	0.57	0.50	0.44
C_5	5.00	2.50	1.67	1.25	1.00	0.83	0.71	0.63	0.56
C_6	6.00	3.00	2.00	1.50	1.20	1.00	0.86	0.75	0.67
C_7	7.00	3.50	2.33	1.75	1.40	1.17	1.00	0.88	0.78
C_8	8.00	4.00	2.67	2.00	1.60	1.33	1.14	1.00	0.89
C_9	9.00	3.50	2.33	1.75	1.80	1.50	1.29	1.13	1.00
Contr. level	1	2	3	4	5	6	7	8	9
Weight	0.023	0.045	0.068	0.090	0.113	0.136	0.158	0.181	0.186
CR	0.008 (consistent)								

If $x_1 < x_2 < x_3 < x_4 < x_5 < x_6 < x_7 < x_8 < x_9$, then $x_1 = 1, x_2 = 2, x_3 = 3, \dots$, and $x_9 = 9$. If criteria C_9 are compared with the other criterion, the consistency ratio will always result in a value greater than 1, as shown in Table 3 (row C_9). Thus, the pairwise comparison matrix of C_9 criteria with other criteria gives consistent results. As the decision maker assigned C_1 the highest value (i.e., weakly or slightly important), the paired comparison value of criteria C_1 versus that of other criteria will always be < 1 . Therefore, C_9 will have the greatest weight. Likewise, the reverse is true for criteria C_1 . Thus, if criteria C_1 is compared with the other criteria, it will always result in a value less than 1 and never more than 1, as shown in Table 3 in the second row (row C_1). Thus, the pairwise comparison matrix of criteria C_1 with other criteria gives consistent results. As the decision maker assigned C_1 the lowest value (i.e., lowest importance), the paired comparison value of criteria C_9 versus that of other criteria will always be > 1 . As a result, C_1 will have the lowest weight. In terms of the other criteria, their weights will be in accordance with the order of the contribution value. Thus, it is logical that the weight of each criterion is determined by its contribution to supplier selection. Therefore, if each criterion makes the same contribution to supplier selection, it will have the same weight. Although all the supplier selection criteria have same value, the weights of all the criteria have the same value, as depicted in Table 4.

The contribution level of a particular criterion can be further evaluated by assigning a value of 0 to 100 (integer number), where 0 indicates no contribution to supplier selection, and 100 indicates the highest contribution (importance) of a criterion to supplier selection. The advantage of using contribution levels between 0 and 100 is the broad scope it gives decision makers to input the value of contributions of various criteria to supplier selection. In addition, if we use only an integer value range between 1 and 9, and there are more than

nine criteria, then some criteria will have the same contribution level. However, if we use an integer value range between 0 and 100, this will minimize the chances of multiple criteria being assigned the same contribution value (level of importance).

Table 4 – Performance of the proposed method using same contribution value

Criteria	C ₁	C ₂	C ₃	C ₄	C ₅	C ₆	C ₇	C ₈	C ₉
	1	1	1	1	1	1	1	1	1
	2	2	2	2	2	2	2	2	2
	3	3	3	3	3	3	3	3	3
	4	4	4	4	4	4	4	4	4
Contribution level	5	5	5	5	5	5	5	5	5
	6	6	6	6	6	6	6	6	6
	7	7	7	7	7	7	7	7	7
	8	8	8	8	8	8	8	8	8
	9	9	9	9	9	9	9	9	9
Weight	0.111	0.111	0.111	0.111	0.111	0.111	0.111	0.111	0.111
CR	0.000 (consistent)								

Testing the proposed method using data from the literature. The proposed method was tested using previous data in which there were nine selection criteria [23, 24]. The pairwise comparison matrix in one study was inconsistent [23], whereas that in the other was consistent [24]. Tables 5 and 6 show the results of assessing the different contribution levels of decision makers for different criteria. As apparent in these tables, the proposed method yielded a consistent pairwise comparison matrix in the presence of more than nine criteria. Thus, the resulting supplier selection criteria will always be valid, regardless of the number of criteria. The proposed method was also capable of making inconsistent pairwise comparison matrices consistent and providing a definitive solution to supplier selection.

Table 5 – Example 1

n/n	[23]	Proposed method			
Criteria	Weight	Contribution level (1-9)	Weight	Contribution level (0-100)	Weight
C ₁	0.291	9	0.181	60	0.327
C ₂	0.229	8	0.161	25	0.136
C ₃	0.114	7	0.141	22	0.120
C ₄	0.114	7	0.141	20	0.109
C ₅	0.036	3	0.060	12	0.065
C ₆	0.037	3	0.060	8	0.044
C ₇	0.036	3	0.060	7	0.038
C ₈	0.068	5	0.100	15	0.082
C ₉	0.052	4	0.076	10	0.052
C ₁₀	0.023	1	0.020	5	0.027
CR	0.184 (inconsistent)	0.022 (consistent)		0.003 (consistent)	

Table 6 – Example 2

	[24]	Proposed method			
Criteria	Weight	Contribution level (1-9)	Weight	Contribution level (0-100)	Weight
C ₁	0.165	9	0.176	60	0.191
C ₂	0.135	8	0.156	45	0.144
C ₃	0.111	6	0.117	32	0.102
C ₄	0.092	4	0.078	28	0.089
C ₅	0.080	4	0.078	25	0.080
C ₆	0.078	4	0.078	24	0.077
C ₇	0.052	2	0.039	15	0.048
C ₈	0.059	2	0.039	18	0.057
C ₉	0.076	4	0.063	23	0.065
C ₁₀	0.104	6	0.117	30	0.096
C ₁₁	0.048	3	0.059	16	0.051
CR	0.008 (consistent)	0.012 (consistent)		0.003 (consistent)	

Comparison of the proposed method with that of Li et al. [19]. We compared the performance of the proposed method with that of Li et al. [19] using data from previous studies [23, [24]. In the pairwise comparison matrix of Hruska et al. [23], the method by Li et al. [19] does not accommodate numbers other than 1, 3, 5, 7, and 9. Thus, number 8 is placed between numbers 7 and 9, number 6 is placed between numbers 5 and 7, and number 4 is placed between numbers 3 and 5. Figure 4 show the results of the pairwise comparison conversion using the method of Hruska et al. [23] and that of Li et al. [9]. As shown in Figure 4, the pairwise comparison matrix based on the method of Li et al. [19] is inconsistent. Although the method used by Li et al. [19] can minimize inconsistencies, when there are more than seven criteria. This is one of the weaknesses of the method [19].

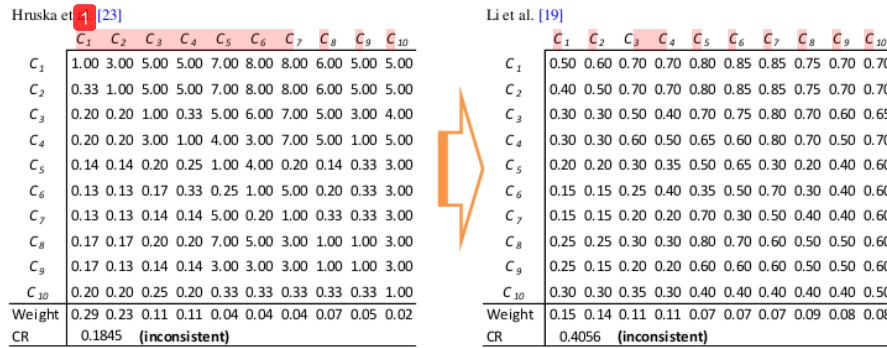

Figure 4 – Li et al. [19] for example 1

Example 2 provides additional evidence illustrating the disadvantages of the method of Li et al. [19]. Thus, the matrix data of by Polat et al. [24] must be rounded first, and then the matrix must be converted using the Li et al.'s method [19]. Figure 5 show the results of the pairwise comparison conversion using the method of Polat et al. [24] and that of Li et al. [9]. As can be seen in this figure, in a matrix that contains more than seven criteria, Li et al.'s method [19] produces an inconsistent solution. Table 7 provides a comparison of the results obtained using the method of Li et al. [19] with those obtained using the proposed method. Based on this table, it can be seen that the proposed method is better than that of Li et al. [19] because it always produces a consistent value. The proposed method is capable of giving a CI value close to zero and a value of zero if the matrix is perfectly consistent [25].

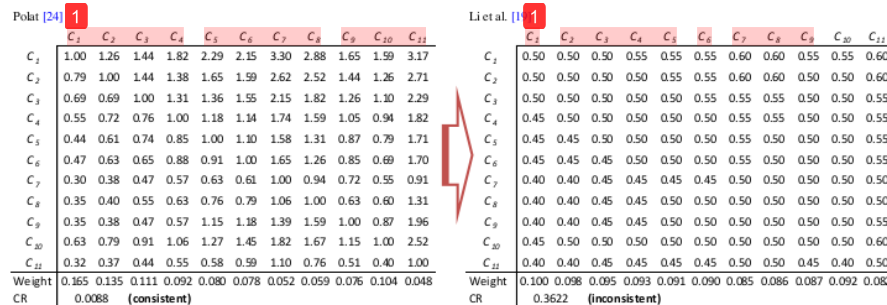

Figure 5 – Li et al. [19] for example 2

Comparison of the proposed method with that of Chandavarkar and Guddeti [18]. The performance of the proposed method was compared with that of Chandavarkar and Guddeti [18]. Chandavarkar and Guddeti [18] to construct a pairwise comparison matrix. In the pairwise comparison matrices of Hruska et al. [23] and Polat et al. [24], $L_p = L_q$. In equation (1), the value assigned to a_{ij} is infinity. Thus, in the method used by Chandavarkar

and Guddeti [18], the a_{ij} value (infinity) is replaced by zero. This is one of the weaknesses of their method [18]. A comparison of the results obtained using their method [18] and those generated using the proposed method is presented in Tables 8 and 9. Based on these tables, it can be seen that the proposed method is better than that of Chandavarkar and Guddeti [18] because it always produces a consistent value. The proposed method is capable of giving a CI value close to zero and a CI value of zero if the matrix is perfectly consistent [25].

Table 7 – Summary of the results obtained using Li et al. [19] and those obtained using the proposed method

Matrix data	Size	Consistency ratio (CR)		
		Original AHP	Li et al. [19]	Proposed method
Hruska et al. [23]	10 x 10	0.1845 (inconsistent)	0.4056 (inconsistent)	0.022 (consistent)
Polat [24]	11 x 11	0.0088 (consistent)	0.3622 (inconsistent)	0.012 (consistent)

Table 8 – Summary of the results obtained using the method Chandavarkar and Guddeti [18] and those obtained using the proposed method for example 1

n/n	[23]	Chandavarkar and Guddeti method [18]	Proposed method	
Criteria	Weight	Weight	Contribution level (1-9)	Weight
C_1	0.291	0.309	9	0.181
C_2	0.229	0.223	8	0.161
C_3	0.114	0.158	7	0.141
C_4	0.114	0.158	7	0.141
C_5	0.036	0.023	3	0.060
C_6	0.037	0.023	3	0.060
C_7	0.036	0.023	3	0.060
C_8	0.068	0.034	5	0.100
C_9	0.052	0.031	4	0.076
C_{10}	0.023	0.018	1	0.020
CR	0.184 (inconsistent)	0.066 (consistent)	0.022 (consistent)	

Table 9 – Summary of the results obtained using the Chandavarkar and Guddeti method [18] and those of the proposed method for example 2

	[24]	Chandavarkar and Guddeti method [18]	Proposed method	
Criteria	Weight	Weight	Contribution level (1-9)	Weight
C_1	0.165	0.382	9	0.181
C_2	0.135	0.289	8	0.161
C_3	0.111	0.151	7	0.141
C_4	0.092	0.039	7	0.141
C_5	0.080	0.039	3	0.060
C_6	0.078	0.039	3	0.060
C_7	0.052	0.007	3	0.060
C_8	0.059	0.007	5	0.100
C_9	0.076	0.005	4	0.076
C_{10}	0.104	0.013	1	0.020
C_{11}	0.048	0.028		
CR	0.008 (consistent)	0.299 (inconsistent)	0.022 (consistent)	

Test of the effect of criteria weight on supplier selection using the proposed method.
 We examined the effect of criteria weight on supplier selection using the proposed method as compared with that using the original AHP. The data used in the test are shown in Tables 10 and 11. These data are performance data from each supplier for each criterion. As shown in the tables, there are six suppliers (SC1, SC2, SC3, SC4, SC5, and SC6).

Table 10 – Supplier data for example 1

Supplier	C_1	C_2	C_3	C_4	C_5	C_6	C_7	C_8	C_9	C_{10}
SC1	8	5	3	1	8	7	8	3	5	3
SC2	10	6	5	2	7	10	5	1	8	1
SC3	10	6	3	3	5	8	6	4	5	5
SC4	9	7	4	2	4	11	2	3	7	0
SC5	12	8	4	2	6	9	4	0	8	2
SC6	10	6	8	4	5	6	3	2	7	1

Table 11 – Supplier data for example 2

Supplier	C_1	C_2	C_3	C_4	C_5	C_6	C_7	C_8	C_9	C_{10}	C_{11}
SC1	8	5	3	1	8	7	8	3	5	3	8
SC2	10	6	5	2	7	10	5	1	8	1	6
SC3	10	6	3	3	5	8	6	4	5	5	10
SC4	9	7	4	2	4	11	2	3	7	0	4
SC5	12	8	4	2	6	9	4	0	8	2	5
SC5	10	6	8	4	5	6	3	2	7	1	9

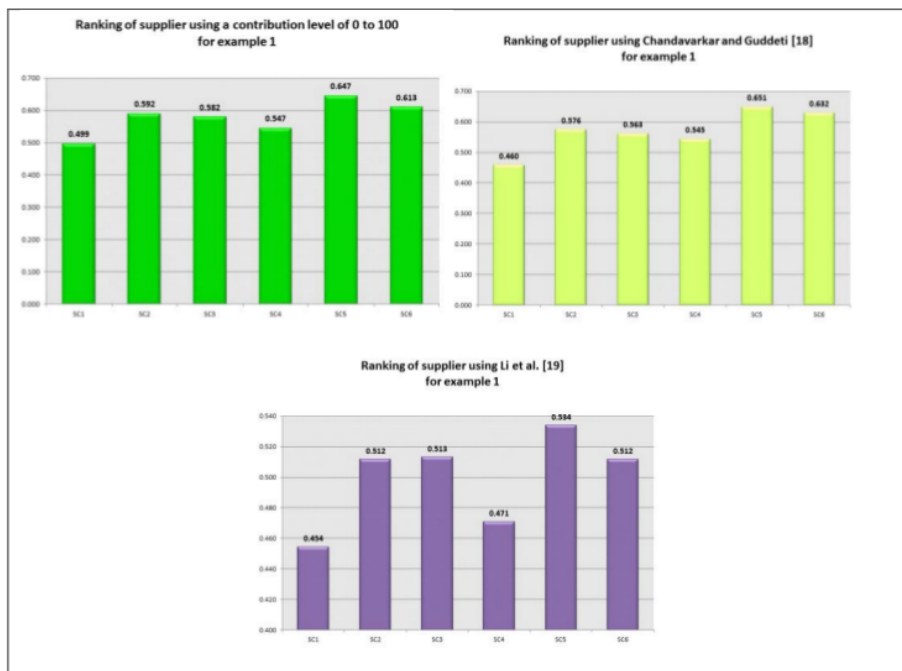

Figure 6 – Supplier selection solution (example 1)

Figure 6 is the result of the proposed method using supplier data in Table 10. Figures 7 is the result of the proposed method using supplier data in Table 11. The results of the sequence of suppliers are the same in Figure 6. Test supplier is SC 5, and the worst supplier is SC 1. It was inconsistent in the pairwise comparison matrices of Hruska et al. [23] but consistent when using the proposed method. Thus, the results obtained by Hruska et al. [23] and those obtained using the method of Li et al. [19] are invalid, although they yield the same solution as that obtained using the proposed method.

Using the pairwise comparison matrix of by Polat [24] gives the solution shown in Figure 7. Figure 7 shows that the solution of the proposed method is the same as that generated using the original AHP. The results obtained using the method of Chandavarkar and Guddeti [18] are invalid, although the method yields the same solution as those generated using the proposed method. Proposed method produce the same solution as that

obtained using a consistent pairwise comparison matrix. An inconsistent matrix results in a different supplier selection solution.

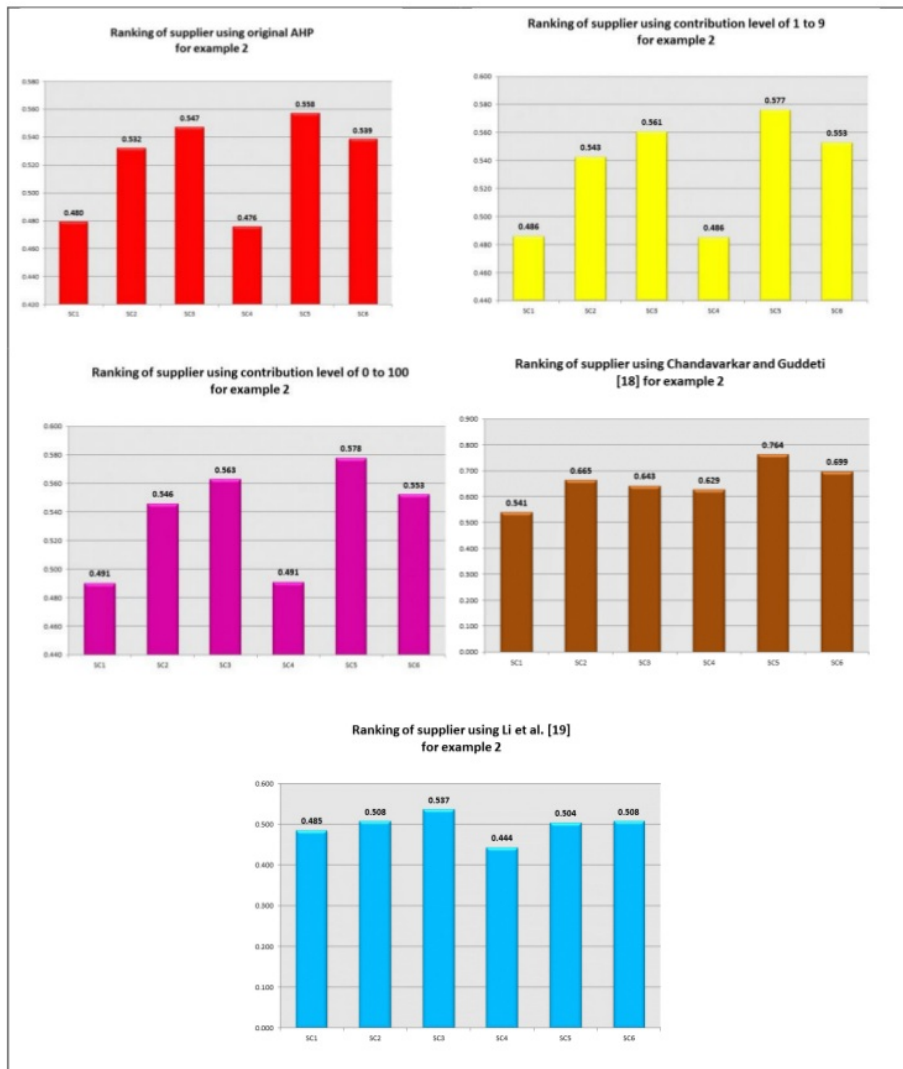

Figure 7 – Supplier selection solution (example 2)

CONCLUSION

The solution obtained using the proposed method is better than that achieved using the method of Li et al. [19] and that of Chandavarkar and Guddeti [18], as the proposed method is capable of generating a valid solution, regardless of the number of criteria and without having to revise the pairwise comparison matrix. The proposed method is also easier to use because decision makers have only to assign a contribution level to each criterion rather than drawing comparisons between criteria. Furthermore, the proposed method is simpler than the original AHP, as it does not require a consistency test. In addition, using the proposed method, the pairwise comparison matrix does not have to be complete.

This research was financially supported by the PDD Program of the Ristekdikti Republic of Indonesia.

Limitations of the study. The proposed method has not been tested using real data.
Conflict of interest. The authors declare that there are no conflicts of interest.

ACKNOWLEDGEMENTS

The authors thank the Ministry of Research, Technology and Higher Education of the Republic of Indonesia for its financial support.

REFERENCES

1. Rezaei, J., Nispeling, T., Sarkis, J., and Tavasszy, L., "A supplier selection life cycle approach integrating traditional and environmental criteria using the best worst method," *Journal of Cleaner Production*, Vol. 135, pp. 577–588, 2016.
2. Chai, J., Liu, J. N. K., and Ngai, E. W. T., "Application of decision-making techniques in supplier selection: A systematic review of literature," *Expert Systems with Applications*, Vol. 40, no. 10, pp. 3872–3885, 2013.
3. Banaeian, N., Mobli, H., Fahimnia, B., Nielsen, I. E., and Omid, M., "Green supplier selection using fuzzy group decision making methods: A case study from the agri-food industry," *Computers & Operations research*, Vol. 89, no. 1, pp. 337-347, 2017.
4. Govindan, K., Rajendran, S., Sarkis, J., and Murugesan, P., "Multi criteria decision making approaches for green supplier evaluation and selection: a literature review," *Journal of Cleaner Production*, Vol. 98, pp. 66 – 83, 2015.
5. Zimmer, K., Fröhling, M., and Schultmann, F., "Sustainable supplier management – a review of models supporting sustainable supplier selection, monitoring and development," *International Journal of Production Research*, Vol. 54, no. 5, pp. 1412-1442, 2017.
6. Rosyidi, C. N., Murtisari, R., and Jauhari, W. A., "A concurrent optimization model for suppliers selection, tolerance and component allocation with fuzzy quality loss," *Cogent Engineering*, Vol. 3, no. 1, pp. 1–10, 2016.
7. Saaty, T. L., "Decision-making with the AHP: Why is the principal eigenvector necessary," *European Journal of Operational Research*, Vol. 145, no. 1, pp. 85–91, 2003.
8. Saaty, T. L., "How to make a decision: The Analytic Hierarchy Process," *European Journal of Operational Research*, Vol. 48, no. 1, pp. 9–26, 1990.
9. Darabi, S. and Heydari, J., "An interval-valued hesitant fuzzy ranking method based on group decision analysis for green supplier selection," *IFAC-paper On Line*, Vol. 49, no. 2, pp. 12–17, 2016.
10. Tavana, M., Fallahpour, A., Di-Caprio, D. and Santos-Arteaga, F. J., "A hybrid intelligent fuzzy predictive model with simulation for supplier evaluation and selection," *Expert Systems With Applications*, Vol. 61, pp. 129–144, 2016.
11. Hamdan, S. and Cheaitou, A., "Supplier selection and order allocation with green criteria: An MCDM and multi-objective optimization approach", *Computers and Operation Research*, Vol. 81, pp. 282 – 304, 2017.
12. Saaty, T. L. and Kearns, K. P., "Analytical planning: The organization systems," Oxford: Pergamon press, pp. 34-36, 1985.
13. Saaty, T. L. and Ozdemir, M. S., "Why the magic number seven plus or minus two," *Mathematical and Computer Modelling*, Vol. 38, no. 3-4, pp. 233–44, 2003.
14. Luzon, B. and El-Sayegh, S. M., "Evaluating supplier selection criteria for oil and gas projects in the UAE using AHP and Delphi," *International Journal of Construction Management*, Vol. 140, no. 3, pp. 1686-1698, 2016.
15. Dweiri, F., Kumar, S., Khan, S. A., and Jain, V., "Designing an integrated AHP based decision support system for supplier selection in automotive industry," *Expert Systems With Applications*, Vol. 62, pp. 273–283, 2016.
16. Pandey, P., Shah, B. J., and Gajjar, H., "A fuzzy goal programming approach for selecting sustainable suppliers," *Benchmarking: An International Journal*, Vol. 24, no. 5, 2017.
17. Luthra, S., Govindan, K., Kannan, D., Mangla, S. K., and Garg, C. P., "An integrated

- framework for sustainable supplier selection and evaluation in supply chains," Journal of Cleaner Production, Vol. 140, no. 3, pp. 1686-1698, 2017.
18. Chandavarkar, B. R. and Guddeti, R. M. R., "Simplified and Improved Analytical Hierarchy Process Aid for Selecting Candidate Network in an Overlay Heterogeneous Networks," Wireless Personal Communications, Vol. 83, no. 4, pp. 2593–2606, 2015.
 19. Li, Z., Li, J., Liang, D., and Lee, T., "Building multilevel governance and partnerships: an evaluation approach," Journal of Entrepreneurship in Emerging Economies, Vol. 8, no. 2, pp. 263 – 278, 2016.
 20. Galankashi, M. R., Helmi, S. A., and Hashemzahi, P., "Supplier selection in automobile industry: A mixed balanced scorecard-fuzzy AHP approach," Alexandria Engineering Journal, Vol. 55, pp. 93 – 100, 2016.
 21. Saaty, T. L., "Rank from comparisons and from ratings in the analytic hierarchy/network processes," European Journal of Operational Research, Vol. 168, no. 2, pp. 557–570, 2006.
 22. Lin, Y. and Xiaohong, D., "The Computation and Application of random consistency index," 2nd International Conference on Information Science and Engineering (ICISE) IEEE, 4-6 Dec 2010, pp. 693 - 695, 2010.
 23. Hruška, R., Průša, P. and Babić, D., "The use of AHP method for selection of supplier," Transport, Vol. 29, no. 2, pp. 195 – 203, 2014.
 24. Polat, G., "Subcontractor selection using the integration of the AHP and PROMETHEE methods," Journal of Civil Engineering and Management, Vol. 22, no. 8, pp. 1042-1054, 2015.
 25. Franek, J. And Kresta, A., "Judgment scales and consistency measure in AHP," Procedia Economics and Finance, Vol. 12, pp. 164 – 173, 2014.

APPENDIX

Criteria C1 is compared with criteria C2	Criteria C2 is compared with criteria C3	Criteria C1 is compared with criteria C3	Consistency ratio (CR)	Conclusion
1	2	½	0.209	Inconsistent
	3	½	0.356	Inconsistent
	4	½	0.490	Inconsistent
	5	½	0.613	Inconsistent
	6	½	0.730	Inconsistent
	7	½	0.843	Inconsistent
	8	½	0.951	Inconsistent
	9	½	1.057	Inconsistent
2	1	½	0.209	Inconsistent
	2	½	0.481	Inconsistent
	3	½	0.700	Inconsistent
	4	½	0.890	Inconsistent
	5	½	1.063	Inconsistent
	6	½	1.224	Inconsistent
	7	½	1.378	Inconsistent
	8	½	1.526	Inconsistent
3	1	½	0.356	Inconsistent
	2	½	0.700	Inconsistent
	3	½	0.967	Inconsistent
	4	½	1.193	Inconsistent
	5	½	1.397	Inconsistent
	6	½	1.586	Inconsistent
	7	½	1.764	Inconsistent
	8	½	1.936	Inconsistent
4	1	½	2.103	Inconsistent
	2	½	0.906	Inconsistent
	3	½	1.450	Inconsistent
	4	½	1.841	Inconsistent
	5	½	2.163	Inconsistent
	6	½	2.448	Inconsistent
	7	½	2.711	Inconsistent
	8	½	2.958	Inconsistent
9	8	½	3.194	Inconsistent
	9	½	3.424	Inconsistent

5	1	½	0.608	Inconsistent
	2	½	1.063	Inconsistent
	3	½	1.400	Inconsistent
	4	½	1.680	Inconsistent
	5	½	1.926	Inconsistent
	6	½	2.152	Inconsistent
	7	½	2.364	Inconsistent
	8	½	2.567	Inconsistent
	9	½	2.762	Inconsistent
6	1	½	0.721	Inconsistent
	2	½	1.224	Inconsistent
	3	½	1.592	Inconsistent
	4	½	1.893	Inconsistent
	5	½	2.157	Inconsistent
	6	½	2.397	Inconsistent
	7	½	2.622	Inconsistent
	8	½	2.836	Inconsistent
	9	½	3.042	Inconsistent
7	1	½	0.829	Inconsistent
	2	½	1.378	Inconsistent
	3	½	1.774	Inconsistent
	4	½	2.096	Inconsistent
	5	½	2.375	Inconsistent
	6	½	2.629	Inconsistent
	7	½	2.865	Inconsistent
	8	½	3.089	Inconsistent
	9	½	3.304	Inconsistent
8	1	½	0.933	Inconsistent
	2	½	1.526	Inconsistent
	3	½	1.949	Inconsistent
	4	½	2.291	Inconsistent
	5	½	2.585	Inconsistent
	6	½	2.851	Inconsistent
	7	½	3.097	Inconsistent
	8	½	3.330	Inconsistent
	9	½	3.553	Inconsistent
9	1	½	1.033	Inconsistent
	2	½	1.670	Inconsistent
	3	½	2.120	Inconsistent
	4	½	2.480	Inconsistent
	5	½	2.789	Inconsistent
	6	½	3.066	Inconsistent
	7	½	3.322	Inconsistent
	8	½	3.563	Inconsistent
	9	½	3.793	Inconsistent
1	1	1/3	0.131	Inconsistent
	2	1/3	0.356	Inconsistent
	3	1/3	0.546	Inconsistent
	4	1/3	0.714	Inconsistent
	5	1/3	0.869	Inconsistent
	6	1/3	1.014	Inconsistent
	7	1/3	1.152	Inconsistent
	8	1/3	1.286	Inconsistent
	9	1/3	1.417	Inconsistent
2	1	1/3	0.356	Inconsistent
	2	1/3	0.700	Inconsistent
	3	1/3	0.967	Inconsistent
	4	1/3	1.195	Inconsistent
	5	1/3	1.400	Inconsistent
	6	1/3	1.592	Inconsistent
	7	1/3	1.774	Inconsistent
	8	1/3	1.949	Inconsistent
	9	1/3	2.120	Inconsistent
3	1	1/3	0.546	Inconsistent
	2	1/3	0.967	Inconsistent
	3	1/3	1.282	Inconsistent
	4	1/3	1.547	Inconsistent
	5	1/3	1.784	Inconsistent
	6	1/3	2.004	Inconsistent
	7	1/3	2.212	Inconsistent
	8	1/3	2.412	Inconsistent
	9	1/3	2.606	Inconsistent

RJOAS, 3(87), March 2019

4	1	1/3	0.711	Inconsistent
	2	1/3	1.193	Inconsistent
	3	1/3	1.547	Inconsistent
	4	1/3	1.841	Inconsistent
	5	1/3	2.102	Inconsistent
	6	1/3	2.342	Inconsistent
	7	1/3	2.568	Inconsistent
	8	1/3	2.786	Inconsistent
	9	1/3	2.996	Inconsistent
5	1	1/3	0.861	Inconsistent
	2	1/3	1.397	Inconsistent
	3	1/3	1.784	Inconsistent
	4	1/3	2.102	Inconsistent
	5	1/3	2.383	Inconsistent
	6	1/3	2.640	Inconsistent
	7	1/3	2.881	Inconsistent
	8	1/3	3.112	Inconsistent
	9	1/3	3.335	Inconsistent
6	1	1/3	0.999	Inconsistent
	2	1/3	1.586	Inconsistent
	3	1/3	2.004	Inconsistent
	4	1/3	2.344	Inconsistent
	5	1/3	2.642	Inconsistent
	6	1/3	2.913	Inconsistent
	7	1/3	3.167	Inconsistent
	8	1/3	3.409	Inconsistent
	9	1/3	3.643	Inconsistent
7	1	1/3	1.130	Inconsistent
	2	1/3	1.764	Inconsistent
	3	1/3	2.212	Inconsistent
	4	1/3	2.573	Inconsistent
	5	1/3	2.886	Inconsistent
	6	1/3	3.170	Inconsistent
	7	1/3	3.436	Inconsistent
	8	1/3	3.688	Inconsistent
	9	1/3	3.930	Inconsistent
8	1	1/3	1.254	Inconsistent
	2	1/3	1.936	Inconsistent
	3	1/3	2.412	Inconsistent
	4	1/3	2.792	Inconsistent
	5	1/3	3.120	Inconsistent
	6	1/3	3.417	Inconsistent
	7	1/3	3.692	Inconsistent
	8	1/3	3.953	Inconsistent
	9	1/3	4.203	Inconsistent
9	1	1/3	1.375	Inconsistent
	2	1/3	2.103	Inconsistent
	3	1/3	2.606	Inconsistent
	4	1/3	3.005	Inconsistent
	5	1/3	3.347	Inconsistent
	6	1/3	3.655	Inconsistent
	7	1/3	3.940	Inconsistent
	8	1/3	4.209	Inconsistent
	9	1/3	4.466	Inconsistent
1	1	1/4	0.211	Inconsistent
	2	1/4	0.487	Inconsistent
	3	1/4	0.711	Inconsistent
	4	1/4	0.906	Inconsistent
	5	1/4	1.084	Inconsistent
	6	1/4	1.250	Inconsistent
	7	1/4	1.408	Inconsistent
	8	1/4	1.561	Inconsistent
	9	1/4	1.709	Inconsistent
2	1	1/4	0.490	Inconsistent
	2	1/4	0.890	Inconsistent
	3	1/4	1.193	Inconsistent
	4	1/4	1.450	Inconsistent
	5	1/4	1.680	Inconsistent
	6	1/4	1.893	Inconsistent
	7	1/4	2.096	Inconsistent
	8	1/4	2.291	Inconsistent
	9	1/4	2.480	Inconsistent

RJOAS, 3(87), March 2019

3	1	¼	0.714	Inconsistent
	2	¼	1.195	Inconsistent
	3	¼	1.547	Inconsistent
	4	¼	1.841	Inconsistent
	5	¼	2.102	Inconsistent
	6	¼	2.344	Inconsistent
	7	¼	2.573	Inconsistent
	8	¼	2.792	Inconsistent
	9	¼	3.005	Inconsistent
4	1	¼	0.906	Inconsistent
	2	¼	1.450	Inconsistent
	3	¼	1.841	Inconsistent
	4	¼	2.163	Inconsistent
	5	¼	2.448	Inconsistent
	6	¼	2.711	Inconsistent
	7	¼	2.958	Inconsistent
	8	¼	3.194	Inconsistent
	9	¼	3.424	Inconsistent
5	1	¼	1.078	Inconsistent
	2	¼	1.677	Inconsistent
	3	¼	2.102	Inconsistent
	4	¼	2.448	Inconsistent
	5	¼	2.753	Inconsistent
	6	¼	3.032	Inconsistent
	7	¼	3.294	Inconsistent
	8	¼	3.544	Inconsistent
	9	¼	3.786	Inconsistent
6	1	¼	1.235	Inconsistent
	2	¼	1.886	Inconsistent
	3	¼	2.342	Inconsistent
	4	¼	2.711	Inconsistent
	5	¼	3.032	Inconsistent
	6	¼	3.325	Inconsistent
	7	¼	3.600	Inconsistent
	8	¼	3.861	Inconsistent
	9	¼	4.113	Inconsistent
7	1	¼	1.383	Inconsistent
	2	¼	2.083	Inconsistent
	3	¼	2.568	Inconsistent
	4	¼	2.958	Inconsistent
	5	¼	3.295	Inconsistent
	6	¼	3.601	Inconsistent
	7	¼	3.886	Inconsistent
	8	¼	4.158	Inconsistent
	9	¼	4.418	Inconsistent
8	1	¼	1.524	Inconsistent
	2	¼	2.272	Inconsistent
	3	¼	2.786	Inconsistent
	4	¼	3.194	Inconsistent
	5	¼	3.547	Inconsistent
	6	¼	3.864	Inconsistent
	7	¼	4.160	Inconsistent
	8	¼	4.439	Inconsistent
	9	¼	4.708	Inconsistent
9	1	¼	1.659	Inconsistent
	2	¼	2.455	Inconsistent
	3	¼	2.996	Inconsistent
	4	¼	3.424	Inconsistent
	5	¼	3.790	Inconsistent
	6	¼	4.119	Inconsistent
	7	¼	4.423	Inconsistent
	8	¼	4.711	Inconsistent
	9	¼	4.987	Inconsistent
1	1	1/5	0.289	Inconsistent
	2	1/5	0.608	Inconsistent
	3	1/5	0.861	Inconsistent
	4	1/5	1.078	Inconsistent
	5	1/5	1.274	Inconsistent
	6	1/5	1.457	Inconsistent
	7	1/5	1.631	Inconsistent
	8	1/5	1.798	Inconsistent
	9	1/5	1.960	Inconsistent

RJOAS, 3(87), March 2019

2	1	1/5	0.613	Inconsistent
	2	1/5	1.063	Inconsistent
	3	1/5	1.397	Inconsistent
	4	1/5	1.677	Inconsistent
	5	1/5	1.926	Inconsistent
	6	1/5	2.157	Inconsistent
	7	1/5	2.375	Inconsistent
	8	1/5	2.585	Inconsistent
	9	1/5	2.789	Inconsistent
3	1	1/5	0.869	Inconsistent
	2	1/5	1.400	Inconsistent
	3	1/5	1.784	Inconsistent
	4	1/5	2.102	Inconsistent
	5	1/5	2.383	Inconsistent
	6	1/5	2.642	Inconsistent
	7	1/5	2.886	Inconsistent
	8	1/5	3.120	Inconsistent
	9	1/5	3.347	Inconsistent
4	1	1/5	1.084	Inconsistent
	2	1/5	1.680	Inconsistent
	3	1/5	2.102	Inconsistent
	4	1/5	2.448	Inconsistent
	5	1/5	2.753	Inconsistent
	6	1/5	3.032	Inconsistent
	7	1/5	3.295	Inconsistent
	8	1/5	3.547	Inconsistent
	9	1/5	3.790	Inconsistent
5	1	1/5	1.274	Inconsistent
	2	1/5	1.926	Inconsistent
	3	1/5	2.383	Inconsistent
	4	1/5	2.753	Inconsistent
	5	1/5	3.077	Inconsistent
	6	1/5	3.373	Inconsistent
	7	1/5	3.650	Inconsistent
	8	1/5	3.915	Inconsistent
	9	1/5	4.170	Inconsistent
6	1	1/5	1.448	Inconsistent
	2	1/5	2.152	Inconsistent
	3	1/5	2.640	Inconsistent
	4	1/5	3.032	Inconsistent
	5	1/5	3.373	Inconsistent
	6	1/5	3.683	Inconsistent
	7	1/5	3.972	Inconsistent
	8	1/5	4.248	Inconsistent
	9	1/5	4.514	Inconsistent
7	1	1/5	1.610	Inconsistent
	2	1/5	2.364	Inconsistent
	3	1/5	2.881	Inconsistent
	4	1/5	3.294	Inconsistent
	5	1/5	3.650	Inconsistent
	6	1/5	3.973	Inconsistent
	7	1/5	4.273	Inconsistent
	8	1/5	4.559	Inconsistent
	9	1/5	4.833	Inconsistent
8	1	1/5	1.763	Inconsistent
	2	1/5	2.567	Inconsistent
	3	1/5	3.112	Inconsistent
	4	1/5	3.544	Inconsistent
	5	1/5	3.915	Inconsistent
	6	1/5	4.249	Inconsistent
	7	1/5	4.559	Inconsistent
	8	1/5	4.853	Inconsistent
	9	1/5	5.136	Inconsistent
9	1	1/5	1.910	Inconsistent
	2	1/5	2.762	Inconsistent
	3	1/5	3.335	Inconsistent
	4	1/5	3.786	Inconsistent
	5	1/5	4.170	Inconsistent
	6	1/5	4.516	Inconsistent
	7	1/5	4.835	Inconsistent
	8	1/5	5.137	Inconsistent
	9	1/5	5.426	Inconsistent

RJOAS, 3(87), March 2019

1	1	1/6	0.364	Inconsistent
	2	1/6	0.721	Inconsistent
	3	1/6	0.999	Inconsistent
	4	1/6	1.235	Inconsistent
	5	1/6	1.448	Inconsistent
	6	1/6	1.645	Inconsistent
	7	1/6	1.831	Inconsistent
	8	1/6	2.010	Inconsistent
	9	1/6	2.184	Inconsistent
2	1	1/6	0.730	Inconsistent
	2	1/6	1.224	Inconsistent
	3	1/6	1.586	Inconsistent
	4	1/6	1.886	Inconsistent
	5	1/6	2.152	Inconsistent
	6	1/6	2.397	Inconsistent
	7	1/6	2.629	Inconsistent
	8	1/6	2.851	Inconsistent
	9	1/6	3.066	Inconsistent
3	1	1/6	1.014	Inconsistent
	2	1/6	1.592	Inconsistent
	3	1/6	2.004	Inconsistent
	4	1/6	2.342	Inconsistent
	5	1/6	2.640	Inconsistent
	6	1/6	2.913	Inconsistent
	7	1/6	3.170	Inconsistent
	8	1/6	3.417	Inconsistent
	9	1/6	3.655	Inconsistent
4	1	1/6	1.250	Inconsistent
	2	1/6	1.893	Inconsistent
	3	1/6	2.344	Inconsistent
	4	1/6	2.711	Inconsistent
	5	1/6	3.032	Inconsistent
	6	1/6	3.325	Inconsistent
	7	1/6	3.601	Inconsistent
	8	1/6	3.864	Inconsistent
	9	1/6	4.119	Inconsistent
5	1	1/6	1.457	Inconsistent
	2	1/6	2.157	Inconsistent
	3	1/6	2.642	Inconsistent
	4	1/6	3.032	Inconsistent
	5	1/6	3.373	Inconsistent
	6	1/6	3.683	Inconsistent
	7	1/6	3.973	Inconsistent
	8	1/6	4.249	Inconsistent
	9	1/6	4.516	Inconsistent
6	1	1/6	1.645	Inconsistent
	2	1/6	2.397	Inconsistent
	3	1/6	2.913	Inconsistent
	4	1/6	3.325	Inconsistent
	5	1/6	3.683	Inconsistent
	6	1/6	4.006	Inconsistent
	7	1/6	4.309	Inconsistent
	8	1/6	4.596	Inconsistent
	9	1/6	4.873	Inconsistent
7	1	1/6	1.610	Inconsistent
	2	1/6	2.364	Inconsistent
	3	1/6	2.881	Inconsistent
	4	1/6	3.294	Inconsistent
	5	1/6	3.650	Inconsistent
	6	1/6	3.973	Inconsistent
	7	1/6	4.273	Inconsistent
	8	1/6	4.559	Inconsistent
	9	1/6	4.833	Inconsistent
8	1	1/6	1.983	Inconsistent
	2	1/6	2.836	Inconsistent
	3	1/6	3.409	Inconsistent
	4	1/6	3.861	Inconsistent
	5	1/6	4.248	Inconsistent
	6	1/6	4.596	Inconsistent
	7	1/6	4.919	Inconsistent
	8	1/6	5.224	Inconsistent
	9	1/6	5.517	Inconsistent

RJOAS, 3(87), March 2019

9	1	1/6	2.141	Inconsistent
	2	1/6	3.042	Inconsistent
	3	1/6	3.643	Inconsistent
	4	1/6	4.113	Inconsistent
	5	1/6	4.514	Inconsistent
	6	1/6	4.873	Inconsistent
	7	1/6	5.204	Inconsistent
	8	1/6	5.517	Inconsistent
	9	1/6	5.817	Inconsistent
1	1	1/7	0.436	Inconsistent
	2	1/7	0.829	Inconsistent
	3	1/7	1.130	Inconsistent
	4	1/7	1.383	Inconsistent
	5	1/7	1.610	Inconsistent
	6	1/7	1.819	Inconsistent
	7	1/7	2.017	Inconsistent
	8	1/7	2.206	Inconsistent
	9	1/7	2.389	Inconsistent
2	1	1/7	0.843	Inconsistent
	2	1/7	1.378	Inconsistent
	3	1/7	1.764	Inconsistent
	4	1/7	2.083	Inconsistent
	5	1/7	2.364	Inconsistent
	6	1/7	2.622	Inconsistent
	7	1/7	2.865	Inconsistent
	8	1/7	3.097	Inconsistent
	9	1/7	3.322	Inconsistent
3	1	1/7	1.152	Inconsistent
	2	1/7	1.774	Inconsistent
	3	1/7	2.212	Inconsistent
	4	1/7	2.568	Inconsistent
	5	1/7	2.881	Inconsistent
	6	1/7	3.167	Inconsistent
	7	1/7	3.436	Inconsistent
	8	1/7	3.692	Inconsistent
	9	1/7	3.940	Inconsistent
4	1	1/7	1.408	Inconsistent
	2	1/7	2.096	Inconsistent
	3	1/7	2.573	Inconsistent
	4	1/7	2.958	Inconsistent
	5	1/7	3.294	Inconsistent
	6	1/7	3.600	Inconsistent
	7	1/7	3.886	Inconsistent
	8	1/7	4.160	Inconsistent
	9	1/7	4.423	Inconsistent
5	1	1/7	1.631	Inconsistent
	2	1/7	2.375	Inconsistent
	3	1/7	2.886	Inconsistent
	4	1/7	3.295	Inconsistent
	5	1/7	3.650	Inconsistent
	6	1/7	3.972	Inconsistent
	7	1/7	4.273	Inconsistent
	8	1/7	4.559	Inconsistent
	9	1/7	4.835	Inconsistent
6	1	1/7	1.831	Inconsistent
	2	1/7	2.629	Inconsistent
	3	1/7	3.170	Inconsistent
	4	1/7	3.601	Inconsistent
	5	1/7	3.973	Inconsistent
	6	1/7	4.309	Inconsistent
	7	1/7	4.622	Inconsistent
	8	1/7	4.919	Inconsistent
	9	1/7	5.204	Inconsistent
7	1	1/7	2.017	Inconsistent
	2	1/7	2.865	Inconsistent
	3	1/7	3.436	Inconsistent
	4	1/7	3.886	Inconsistent
	5	1/7	4.273	Inconsistent
	6	1/7	4.622	Inconsistent
	7	1/7	4.945	Inconsistent
	8	1/7	5.251	Inconsistent
	9	1/7	5.546	Inconsistent

RJOAS, 3(87), March 2019

8	1	1/7	2.191	Inconsistent
	2	1/7	3.089	Inconsistent
	3	1/7	3.688	Inconsistent
	4	1/7	4.158	Inconsistent
	5	1/7	4.559	Inconsistent
	6	1/7	4.918	Inconsistent
	7	1/7	5.251	Inconsistent
	8	1/7	5.566	Inconsistent
	9	1/7	5.868	Inconsistent
9	1	1/7	2.357	Inconsistent
	2	1/7	3.304	Inconsistent
	3	1/7	3.930	Inconsistent
	4	1/7	4.418	Inconsistent
	5	1/7	4.833	Inconsistent
	6	1/7	5.204	Inconsistent
	7	1/7	5.546	Inconsistent
	8	1/7	5.868	Inconsistent
	9	1/7	6.177	Inconsistent
1	1	1/8	0.507	Inconsistent
	2	1/8	0.933	Inconsistent
	3	1/8	1.254	Inconsistent
	4	1/8	1.524	Inconsistent
	5	1/8	1.763	Inconsistent
	6	1/8	1.983	Inconsistent
	7	1/8	2.191	Inconsistent
	8	1/8	2.389	Inconsistent
	9	1/8	2.581	Inconsistent
2	1	1/8	0.951	Inconsistent
	2	1/8	1.526	Inconsistent
	3	1/8	1.936	Inconsistent
	4	1/8	2.272	Inconsistent
	5	1/8	2.567	Inconsistent
	6	1/8	2.836	Inconsistent
	7	1/8	3.089	Inconsistent
	8	1/8	3.330	Inconsistent
	9	1/8	3.563	Inconsistent
3	1	1/8	1.286	Inconsistent
	2	1/8	1.949	Inconsistent
	3	1/8	2.412	Inconsistent
	4	1/8	2.786	Inconsistent
	5	1/8	3.112	Inconsistent
	6	1/8	3.409	Inconsistent
	7	1/8	3.688	Inconsistent
	8	1/8	3.953	Inconsistent
	9	1/8	4.209	Inconsistent
4	1	1/8	1.561	Inconsistent
	2	1/8	2.291	Inconsistent
	3	1/8	2.792	Inconsistent
	4	1/8	3.194	Inconsistent
	5	1/8	3.544	Inconsistent
	6	1/8	3.861	Inconsistent
	7	1/8	4.158	Inconsistent
	8	1/8	4.439	Inconsistent
	9	1/8	4.711	Inconsistent
5	1	1/8	1.798	Inconsistent
	2	1/8	2.585	Inconsistent
	3	1/8	3.120	Inconsistent
	4	1/8	3.547	Inconsistent
	5	1/8	3.915	Inconsistent
	6	1/8	4.248	Inconsistent
	7	1/8	4.559	Inconsistent
	8	1/8	4.853	Inconsistent
	9	1/8	5.137	Inconsistent
6	1	1/8	2.010	Inconsistent
	2	1/8	2.851	Inconsistent
	3	1/8	3.417	Inconsistent
	4	1/8	3.864	Inconsistent
	5	1/8	4.249	Inconsistent
	6	1/8	4.596	Inconsistent
	7	1/8	4.918	Inconsistent
	8	1/8	5.224	Inconsistent
	9	1/8	5.517	Inconsistent

RJOAS, 3(87), March 2019

7	1	1/8	2.206	Inconsistent
	2	1/8	3.097	Inconsistent
	3	1/8	3.692	Inconsistent
	4	1/8	4.160	Inconsistent
	5	1/8	4.559	Inconsistent
	6	1/8	4.919	Inconsistent
	7	1/8	5.251	Inconsistent
	8	1/8	5.566	Inconsistent
	9	1/8	5.868	Inconsistent
8	1	1/8	2.389	Inconsistent
	2	1/8	3.330	Inconsistent
	3	1/8	3.953	Inconsistent
	4	1/8	4.439	Inconsistent
	5	1/8	4.853	Inconsistent
	6	1/8	5.224	Inconsistent
	7	1/8	5.566	Inconsistent
	8	1/8	5.889	Inconsistent
	9	1/8	6.199	Inconsistent
9	1	1/8	2.563	Inconsistent
	2	1/8	3.553	Inconsistent
	3	1/8	4.203	Inconsistent
	4	1/8	4.708	Inconsistent
	5	1/8	5.136	Inconsistent
	6	1/8	5.517	Inconsistent
	7	1/8	5.868	Inconsistent
	8	1/8	6.199	Inconsistent
	9	1/8	6.515	Inconsistent
1	1	1/9	0.576	Inconsistent
	2	1/9	1.033	Inconsistent
	3	1/9	1.375	Inconsistent
	4	1/9	1.659	Inconsistent
	5	1/9	1.910	Inconsistent
	6	1/9	2.141	Inconsistent
	7	1/9	2.357	Inconsistent
	8	1/9	2.563	Inconsistent
	9	1/9	2.762	Inconsistent
2	1	1/9	1.057	Inconsistent
	2	1/9	1.670	Inconsistent
	3	1/9	2.103	Inconsistent
	4	1/9	2.455	Inconsistent
	5	1/9	2.762	Inconsistent
	6	1/9	3.042	Inconsistent
	7	1/9	3.304	Inconsistent
	8	1/9	3.553	Inconsistent
	9	1/9	3.793	Inconsistent
3	1	1/9	1.417	Inconsistent
	2	1/9	2.120	Inconsistent
	3	1/9	2.606	Inconsistent
	4	1/9	2.996	Inconsistent
	5	1/9	3.335	Inconsistent
	6	1/9	3.643	Inconsistent
	7	1/9	3.930	Inconsistent
	8	1/9	4.203	Inconsistent
	9	1/9	4.466	Inconsistent
4	1	1/9	1.709	Inconsistent
	2	1/9	2.480	Inconsistent
	3	1/9	3.005	Inconsistent
	4	1/9	3.424	Inconsistent
	5	1/9	3.786	Inconsistent
	6	1/9	4.113	Inconsistent
	7	1/9	4.418	Inconsistent
	8	1/9	4.708	Inconsistent
	9	1/9	4.987	Inconsistent
5	1	1/9	1.960	Inconsistent
	2	1/9	2.789	Inconsistent
	3	1/9	3.347	Inconsistent
	4	1/9	3.790	Inconsistent
	5	1/9	4.170	Inconsistent
	6	1/9	4.514	Inconsistent
	7	1/9	4.833	Inconsistent
	8	1/9	5.136	Inconsistent
	9	1/9	5.426	Inconsistent

RJOAS, 3(87), March 2019

6	1	1/9	2.184	Inconsistent
	2	1/9	3.066	Inconsistent
	3	1/9	3.655	Inconsistent
	4	1/9	4.119	Inconsistent
	5	1/9	4.516	Inconsistent
	6	1/9	4.873	Inconsistent
	7	1/9	5.204	Inconsistent
	8	1/9	5.517	Inconsistent
	9	1/9	5.817	Inconsistent
7	1	1/9	2.389	Inconsistent
	2	1/9	3.322	Inconsistent
	3	1/9	3.940	Inconsistent
	4	1/9	4.423	Inconsistent
	5	1/9	4.835	Inconsistent
	6	1/9	5.204	Inconsistent
	7	1/9	5.546	Inconsistent
	8	1/9	5.868	Inconsistent
	9	1/9	6.177	Inconsistent
8	1	1/9	2.581	Inconsistent
	2	1/9	3.563	Inconsistent
	3	1/9	4.209	Inconsistent
	4	1/9	4.711	Inconsistent
	5	1/9	5.137	Inconsistent
	6	1/9	5.517	Inconsistent
	7	1/9	5.868	Inconsistent
	8	1/9	6.199	Inconsistent
	9	1/9	6.515	Inconsistent
9	1	1/9	2.762	Inconsistent
	2	1/9	3.793	Inconsistent
	3	1/9	4.466	Inconsistent
	4	1/9	4.987	Inconsistent
	5	1/9	5.426	Inconsistent
	6	1/9	5.817	Inconsistent
	7	1/9	6.177	Inconsistent
	8	1/9	6.515	Inconsistent
	9	1/9	6.838	Inconsistent

NEW METHOD OF CRITERIA WEIGHTING FOR SUPPLIER SELECTION

ORIGINALITY REPORT

2%

SIMILARITY INDEX

0%

INTERNET SOURCES

2%

PUBLICATIONS

%

STUDENT PAPERS

PRIMARY SOURCES

1

"Intelligent and Fuzzy Techniques: Smart and Innovative Solutions", Springer Science and Business Media LLC, 2021

Publication

2%

Exclude quotes On

Exclude matches < 2%

Exclude bibliography On