

LEMBAR
HASIL PENILAIAN SEJAWAT SEBIDANG ATAU PEER REVIEW
KARYA ILMIAH : JURNAL ILMIAH

Judul Karya Ilmiah (Artikel) : EFFECT OF HUMAN RESOURCE CAPABILITY AND TECHNOLOGY ON ORGANIZATIONAL PERFORMANCE: MODERATING ROLE OF ORGANIZATIONAL CULTURE

Penulis Jurnal Ilmiah : M. Farid Wajdi, Marlina Widiyanti, Desmintari, Purbudi Wahyuni

Identitas Jurnal Ilmiah :

- a. Nama Jurnal : Talent Development & Excellence
- b. Nomor/Volume : 12/1
- c. Edisi (bulan/tahun) : Juni, 2020
- d. Penerbit : JTDE
- e. Url dokumen : <http://eprints.upnyk.ac.id/id/eprint/24810>

Hasil Penilaian Peer Review :

Komponen Yang Dinilai	Nilai Maksimal Jurnal Ilmiah					Nilai Akhir Yang Diperoleh
	Internasional Bereputasi <input checked="" type="checkbox"/>	Internasional <input type="checkbox"/>	Nasional Terakreditasi <input type="checkbox"/>	Nasional Tidak Terakreditasi <input type="checkbox"/>	Nasional Terindeks DOAJ <input type="checkbox"/>	
a. Kelengkapan unsur isi Jurnal (10%)	3					2,7
b. Ruang lingkup dan kedalaman pembahasan (30%)	9					8,8
c. Kecukupan dan kemutakhiran data/informasi dan metodologi (30%)	9					8,6
d. Kelengkapan unsur dan kualitas penerbit (30%)	9					8,8
Total = (100%)	30					28,9
Kontribusi Pengusul 13,33%						3,85
Komentar Peer Review	<p>1. Tentang kelengkapan unsur isi Jurnal <i>unsur isi jurnal cukup lengkap yaitu terdapat introduction, literatur review, method, result, dll.</i></p> <p>2. Tentang ruang lingkup dan kedalaman pembahasan <i>pembahasan cukup mendalam yaitu mengenai bagaimana pengaruh kemampuan sumber daya manusia & teknologi pada kinerja organisasi</i></p> <p>3. Tentang kecukupan dan kemutakhiran data/informasi dan metodologi <i>data/informasi & metodologi cukup mutakhir yaitu menggunakan perdebatan kuantitatif</i></p> <p>4. Tentang Kelengkapan unsur dan kualitas penerbit <i>Penerbit sangat berkualitas yaitu terindeks Scopus & scimagojr Q4</i></p>					

Yogyakarta, 1 Maret 2021

Reviewer 2

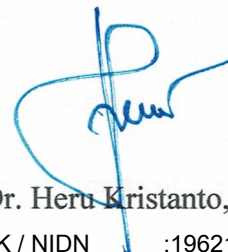

(Dr. Heru Kristanto, HC, M.Si)

NIK / NIDN : 19621219 198803 1 001
 Unit Kerja : FEB UPN "Veteran" Yogyakarta
 Jabatan / Pangkat : Lektor Kepala / Pembina

**LEMBAR
HASIL PENILAIAN SEJAWAT SEBIDANG ATAU PEER REVIEW
KARYA ILMIAH : JURNAL ILMIAH**

Judul Karya Ilmiah (Artikel) : EFFECT OF HUMAN RESOURCE CAPABILITY AND TECHNOLOGY ON ORGANIZATIONAL PERFORMANCE: MODERATING ROLE OF ORGANIZATIONAL CULTURE

Penulis Jurnal Ilmiah : M. Farid Wajdi, Marlina Widiyanti, Desmintari, Purbudi Wahyuni

Identitas Jurnal Ilmiah :

- a. Nama Jurnal : Talent Development & Excellence
- b. Nomor/Volume : 12/1
- c. Edisi (bulan/tahun) : Juni, 2020
- d. Penerbit : JTDE
- e. Url dokumen : <http://eprints.upnyk.ac.id/id/eprint/24810>

Hasil Penilaian Peer Review :

Komponen Yang Dinilai	Nilai Maksimal Jurnal Ilmiah					Nilai Akhir Yang Diperoleh
	Internasional Bereputasi <input checked="" type="checkbox"/>	Internasional <input type="checkbox"/>	Nasional Terakreditasi <input type="checkbox"/>	Nasional Tidak Terakreditasi <input type="checkbox"/>	Nasional Terindeks DOAJ <input type="checkbox"/>	
a. Kelengkapan unsur isi Jurnal (10%)	3					2,7
b. Ruang lingkup dan kedalaman pembahasan (30%)	9					8,8
c. Kecukupan dan kemutakhiran data/informasi dan metodologi (30%)	9					8,6
d. Kelengkapan unsur dan kualitas penerbit (30%)	9					8,7
Total = (100%)	30					28,8
Kontribusi Pengusul 13,3%						3,83
Komentar Peer Review	1. Tentang kelengkapan unsur isi Jurnal <i>cukup, lengkap, terdapat abstrak, introduction, literature review, metodologi, findings dll.</i> 2. Tentang ruang lingkup dan kedalaman pembahasan <i>cukup, dalam, yaitu kemampuan sumber daya manusia dan teknologi pada tenaga organisasi dengan budaya organisasi yang ada</i> 3. Tentang kecukupan dan kemutakhiran data/informasi dan metodologi <i>ada dan metodologi cukup, menyajikan penelitian kualitatif</i> 4. Tentang Kelengkapan unsur dan kualitas penerbit..... <i>secukupnya sesuai dg</i>					

Yogyakarta, 1 Maret 2021

Reviewer 1,



(Dr. Winarno, MM)

NIK / NIDN : 19650716 199203 1 001
 Unit Kerja : FEB UPN "Veteran" Yogyakarta
 Jabatan / Pangkat : Lektor Kepala / Pembina

Effect of Human Resource Capability and Technology on Organizational performance: Moderating role of Organizational Culture

M. Farid Wajdi ^{1*}, Marlina Widiyanti ², Desmintari ³, Purbudi Wahyuni ⁴

¹Faculty of Economics and Business, Universitas Muhammadiyah Surakarta, Indonesia.

²Faculty of Economics, Universitas Sriwijaya, Indonesia.

³Faculty of Economics and Business, Universitas Pembangunan Nasional Veteran Jakarta, Indonesia.

⁴Faculty of Economics and Business, Universitas Pembangunan Nasional Veteran Yogyakarta, Indonesia.

*Coressponding Email: farid.wajdi@ums.ac.id

Abstract

The present study examined the role of technology, human resource capabilities on the organizational performance of small business enterprises (SMEs) in Indonesia. In addition, the role of organizational culture in causal aspect was also investigated as the moderating role of organizational culture among the relationship of human resource capabilities and technology on organizational performance. A total of 244 valid responses have been taken by the distribution of self-administrative questionnaires among the respondents of the study. One of the probability sampling, simple random sampling has employed to get the response. With regards to the proposed hypotheses all the direct hypotheses have significant and positive impact on the organizational behaviour. The findings of the study revealed that the human resource capabilities, technology significantly and positively influence the organizational performance. Nevertheless, the moderating effects of organizational culture among the relationship of human resource capabilities, innovation on organizational performance have been reported not supported. Generally, these results supported the view that the human resource capabilities like training and development, skills, innovation with the help of adoption of latest technology can enhance the organizational performance. In addition, increase the competitiveness of the organization. Finally, the theoretical, methodological and practical implications as well as limitations and suggestions for future research are provided in this study.

Keywords: Organizational Performance, Technology, Human Resource Capabilities, Organizational Culture.

Introduction

In the context of growing global competition, enhancing customer demand and varying corporate settings, business organizations are required to improve their performance constantly. To deal with this environment, innovation with regard to the market offerings, operations, quality and output is helpful for business organizations (Fernando, Jabbour, & Wah, 2019). Additionally, it is recommended that in the contemporary dynamic environment, tangible resources are not as much significant for entities as organizational performance and competitiveness is important. Currently, collective resources with regard to the information technology and human are regarded highly valuable resources of the business. Information technology (IT) is considered as a key element that restructure all aspects of the business with

new scales in the contemporary age of digital technology (Haseeb, Hussain, Kot, Androniceanu, & Jermstittiparsert, 2019). However, IT and HR are regarded as the elements that results in the attainment of competitive advantage in the dynamic, complex and globalised business settings (Garg, 2014; Monday, 2015). With the transformation of society from industrial to information, technological advancement has removed the geographical barriers of and world has become a globalized village. Businesses are availing opportunities with regard to the cost, quality, time and delivery with the help of information and communication advancement. Particularly, developments in the context of technologies results in the development of business layouts that ultimately leads to the access of new markets where they sell their products, enhance productivity of the operations, customer satisfaction and ensuring their loyalty (Boons, Montalvo, Quist, & Wagner, 2013). Moreover, it is tool and technique for businesses that enhance business access of the useful information (Dao, Langella, & Carbo, 2011). IT is defined as a technology with general purpose instead of a conservative capital investment (Wirtenberg, Lipsky, Abrams, Conway, & Slepian, 2007). In the last two decades, IT witnesses rapid and significant developments. Hence, with the increasing application of IT, it is essential to study the impact of these technologies with relation to the performance of organization. In addition, Human Resource Development (HRD) has become a key element of the business organization in the context of restructuring infrastructure, advancing business operations, increasing information, innovativeness or other organizational perspectives. In the complex business settings, the returns curtailing from investments in HR are regarded by researches practically as well as theoretically (Chitrao, 2015). The notion is highly applicable in the current settings where emphasis is paid to the innovative and information-oriented organizations. Accordingly, HR have a central role in the better performance of organization. In the literature, many attempts have been initiated to evaluate the intervening constructs with regard to the association however, this research adopts a more synthesized model to address the dimensions of the relation that are not incorporated (Lee, Phan, & Chan, 2005). With the beginning of organizational HR, HRM practices are initiated with the purpose of recruiting, expansion, and motivation of the human resources for the achievement of higher organizational performance. Furthermore, Barney (1991b) came up with the opinion that HRM practices are significant element for the organizational performance that is why these practices must be regarded as a key element of the organizational planning. There are numerous theories in the literature that support this opinion that human resources must be regarded as the crucial and significant resource for any business. In particular, the theories of resource-based (RBV) and knowledge-based (KBV) incorporated this opinion and regarded human resources equally important for the organizational performance similar to the other traditional resources. A variety of HRM practices have been adopted by business executives for attaining higher business outcomes that consisting of recruitment, performance evaluation, staff development, and reward management (Snell, 2011). Study of these practices provides many perspectives for the strategic management researchers that ultimately leads to the developments in the business economics, organizational competitiveness and the working conditions of employees (Ulrich, Younger, Brockbank, & Ulrich, 2012). Human resources management (HRM) has crucial role with regard to the management for business in achieving higher performance and competitiveness. In the contemporary corporate settings, business necessities are changing in

response to the developed IT and globalization. Accordingly, some questions arise that whether HRM enables firms to obtain information and creation of knowledge and what relation prevails between HRM and organizational performance. In the last decade, there are many studies conducted by researchers which examine the association of HRM practices and performance of an organization (Brockbank, Ulrich, Younger, & Ulrich, 2012; Wright, Gardner, & Moynihan, 2003). Studies concluded that appropriate application of these practices enhance performance of organization. Numerous empirical researches concluded a causal association among HRM practices and outcomes of a business but intermediate association between the variables remained as a “black box”. Rest of the studies on the topic examined the association of HRM practices and organizational performance. However, HRM practices and employee performance was evaluated separately. Another gap is the feedback of employees that has not been considered so far in the research. With the absence of the employee feedback, it can never be determined that HRM practices are helpful for workers or these practices are only enhancing workload, stress level and responsibilities of employees that results in the negative work life (Lopez-Cabrales, Pérez-Luño, & Cabrera, 2009). Moreover, researchers in the past paid their focus only on the measure criteria of the performance and on the enhancement of the monetary outcomes (Carmeli & Tishler, 2004). On the other hand, this study has highlighted the limitations of previous studies and demonstrating a number of advantages for the evaluation of variability of outcomes regarding HRM that include motivation, responsibility, less turnover, training and level of absenteeism (Boselie, Paauwe, & Jansen, 2001). Lastly, conclusions drawn on the relation of HRM practices and organizational performance are inadequate because of the unnecessary dependence upon only respondent and self-reporting (Arthur & Boyles, 2007) that restrict the analysis and limit the researchers to study the organisation in broader context. In addition, the common causal association among these practices form a significant phenomenon for researchers and managers. In the literature, researchers concluded regarding the the practical validation of HRM restriction and comprehensive description of their contribution to the creation of information and their mutual association particularly with relation to the waste application of IT. By all, evaluation is essential that HRM competences and technology play significant role in the higher performance of organization. Hence, this research untended to examine the association of HRM capabilities, technology and performance with the moderating influence of of organizational culture.

Literature Review

Organizational Performance

In prior studies, organizational performance is considered as dependent variable frequently (Carmeli & Tishler, 2004; Zack, McKeen, & Singh, 2009). In particular, business strategy context incorporates performance of organization for the estimation and further understanding of the phenomenon. Accordingly, Combs, Crook, and Shook (2005) diverted their consideration towards Organizational performance with the view of critical perspective. For the purpose, researchers paid more focus for the the examination of the elements and processes that have impact on the performance of the business in positive or negative manners (Jing & Avery, 2008). Nevertheless, there is lack of a comprehensive definition in the literature of organizational strategy that may be equally applicable for all organizations in all circumstances

(Hakimah, Nugraha, Fitri, Manihuruk, & Hasibuan, 2019). In response to this, a further debate prevails in the relevant literature regarding organizational performance and its operations. Similarly, Antony and Bhattacharyya (2010) explained performance as the success achieved by a business in relation to value creation for customers and delivering that value to the internal as well as external customers. Moreover, researchers have opinion that organizations must consider internal factors of organization as well in the contemporary dynamic world of competition (Parast & Adams, 2012). In the literature, measurement of organizational performance is widely discussed. In accordance with the issue, there are two groups of scholars with two different opinions. One group of researchers have the opinion that financial indicators should be used for the measurement of performance. In the prior studies, this approach for the performance measurement is widely applied (Jusoh, Ibrahim, & Zainuddin, 2008). More specifically, it can be concluded that commonly scholars are measuring performance on the basis of stats and numeric (Demirbag, Tatoglu, Tekinkus, & Zaim, 2006). However, this method of measurement remained under continuous debate in the research (Jusoh et al., 2008). Extensive review of the literature suggests that there is a high level of diversity exists in the measuring indicators of organizational performance appropriately (Combs et al., 2005). Therefore, it is considered that organizational performance measurement in appropriate manners is not a simple task. Furthermore, researchers must be careful and comprehensive and must have appropriate justification at the time of selecting indicators that adequately represent the required data for the performance measurement. More specifically, researchers have broadly classified measuring indicators into financial and non-financial indicators with regard to the situation that what measuring indicators best indicate the performance in the context of specific market and economy (Carmeli & Tishler, 2004; Combs et al., 2005). By keeping in view, the above opinions from the previous studies, critical nature of non-financial indicators of performance measurement can be understood. Hence, this study considers non-financial indicators for the measurement of organizational performance.

Human resource capabilities and Organizational Performances

According to the RBV, capabilities, competences, skills or strategic resources are the key drivers for the long-term competitiveness (Mabey, Salaman, & Storey, 1998) as these attributes are valuable, unique and not easy to substitute (Barney, 1991a). Capabilities consisting upon the ability to integrate and recombine useful assets. Key attributes of capabilities are appropriateness, situation relevancy and non-permanency (Bhatt, 2000). Accordingly, Moeller (2009) described capability as the ability of business of applying and managing resources, both tangible and intangible, for undertaking a specific task or for the performance enhancement. Some of the significant attributes of capabilities are that these are based on knowledge, specific to a particular organization, complex in nature, commonly are not available in the market and are developed inside a business (Maritan, 2001). In the same way, Bhatnagar and Sharma (2005) concluded that competence of a business to acquire, encourage, retain and apply human resources with the help of HR strategies and practices results in the HR capabilities. Moreover, HR capabilities depends upon the allocation, carrying and sharing information among the human resources of an organization (Saa-Perez & Garcia-Falcon, 2002). For the higher competitiveness of a business, researchers suggest that HR practices must be perform well as

compare to their competitors (Chang & Huang, 2010). For the accomplishment of this goal, a combination of appropriated established HR practices may lead to the sustained competitiveness. In the literature, researchers recommended various HR common practices include Bhatnagar (2007) evaluated aspects of employee's recruitment, performance assessment, reward management, task design, grievance handling, information flow, behaviour assessment and employee's participation have impact on the performance of organization. Besides, Khandekar and Sharma (2006) have opinion that most widely used HR practices are use of internal career rankings, appropriate training and education methods, performance-based appraisal and payments, job safety, employee opinion and wider job description. Additionally, Vlachos (2008) highlighted seven HR practices that are including job security, recruiting, self-organized groups, highly paid rewards in result of higher organizational performance, comprehensive training, equality among workers and communication of knowledge. In addition, various classes of HR practices are formed into more common HR perspectives. Illustratively, Wright and Kehoe (2008) classified HR practices into planning, staffing, compensation, growth, assessment and communication. Similarly, Schuler, Jackson, Jackofsky, and Slocum Jr (1996) incorporated five extents that are planning, staffing, assessing, compensating and developing. Richard and Johnson (2001) stated that institutional frameworks consider organisations as the bodies that require acceptance of their activities in an environment that is socially established. Main stakeholders at the firm level, first line managers and second line managers, opt the superior HRM practices (Tsui, 1987). Expectations of stakeholders regulate the HRM practices increasingly that include hiring and selection, training and development, performance evaluation, reward management and relationship with the workers. These HRM practices are incorporated as dimensions of HR practices in the context of this study. Existence of these activities indicate the HR professional information level and capabilities of resource distribution. Since 1980s, HR related studies linked with OP had drawn mix conclusions. Many of them concluded neutral association between the HR planning and organizational performance (Mahadeo, Soobaroyen, & Hanuman, 2012). However, some of the studies found significant association among the variables under consideration. Appropriate allocation of resources positively influence the profitability of a business (Hakimah et al., 2019). However, human resources commonly influence OP positively and significantly (Maditinos, Chatzoudes, Tsairidis, & Theriou, 2011; Rosenbusch, Brinckmann, & Müller, 2013). In addition, competitive human resource has a significant association with the profitability of a business (Patel, Messersmith, & Lepak, 2013), and HR as intellectual resource positively and significantly influence financial outcomes of a business (Komnenic & Pokrajcic, 2012). Furthermore, efficacy of human resource is regarded as the efficacy of an organization by attracting HR talent that ultimately enhance motivation level. Also, human resource competitiveness combined with the unique cultural qualities lead to an organization toward organizational competitiveness. By all, human resources are significant for the better performance of an organization (Enkel, Rosenø, & Mezger, 2012).

H1: Human resource practices and organizational performance are significantly associated with each other.

Technology and Organizational Performance

Application of Information Technology (IT) for the improvement of productivity is a key factor for the new entrants in the market. Unique features of technology that include cost, flexibility and efficacy (speed and accuracy) encourage consumers for consistent and appropriate technological use for individual as well as business purposes. IT implication outcomes regarding productivity have widely discussed by the researchers in the literature with respect to the adoption and application (Nugraha & Hakimah, 2019). Though, maximum studies on the topic have evaluated purpose behind its implementation (Teo, Wei, & Benbasat, 2003) and application behaviour in actual (Thatcher, Foster, & Zhu, 2006; Venkatesh & Bala, 2008). Hence, the hypothesis remained under wide consideration of the researchers that application of technology results in the improved organizational performance particularly in the context of SMEs. So, it can be regarded as the core research gap that motivate scholars to integrate technology adoption-diffusion behaviour with the performance of organization for the examination of IT impact on the performance of SME (Zafar, Kousar, & Sabir, 2019). Theories related to innovation adoption describe the situation of adoption and diffusion with the incorporation of intention (Fishbein, 1981; Venkatesh, Thong, & Xu, 2012). There are critical opinions prevails of the researchers regarding existing theories that intention is the predictor of adopter's inner feeling of dogmas that often fail to adequately explain real behaviour in the state of incomplete volitional control. Moreover, intention is not appropriate predictor of decision if there is a time gap between intention and behaviour in actual. Accordingly, a research study regarding technology adoption has examined the contribution of behavioural expectation for the purpose of avoiding the incapacities of cognitive element that is behavioural intention. According to the new perspective, behavioural expectation is not regarded as cognitive element and it addresses the significance of numerous internal as well as external elements (Kousar, Zafar, Sabir, & Sajjad, 2019; Venkatesh & Bala, 2008). Hence, examination of behavioural expectation and its role towards the IT application in the context of an organisation was not studied appropriately. Jain and Khurana (2016) stated that technology is a knowledge, application and formation of system, machinery, tools, methods and approaches accepted and applied by an organization for resolving prevailed challenges or conducting a definite procedure. Technology has a key contribution in competitive market by increasing competitiveness by applying cost effectiveness or differentiation approaches (Nugraha & Hakimah, 2019). Moreover, it enhances abilities of HR regarding to explore, manage and enhance resources that will improve efficiency and productivity (Simon & Shallone, 2013). Likewise, Masnita, Yakub, Nugraha, and Riorini (2019) concluded that technology support a business start innovation processes, product innovation and acclimatize to new market segments that will enhance market size and share. This expanded market participation and size will result in the economies of scale and learning effects that ultimately decrease production expenses. With regard to the production industry, technological innovation is regarded as of key importance for the expansion of resource efficiency and environmental protection (Hollen, Van Den Bosch, & Volberda, 2013).

H2: Technology and organizational performance has a significant association with each other.

Moderating Role of Organizational Culture

Denison (1984) indicated that prominent association prevails between organization culture and decision-making. Moreover, he concluded culture as short-term predictor of performance. Gordon and DiTomaso (1992) also recommended that culture predict organizational performance in short run. Denison (1984) developed his research on the basis of trait approach where he discussed participation, reliability, flexibility and long run targets. These integrated traits produce efficiency because measures for the organizational performance depends upon the variety of subjective measures of performance that consisting of product development, market participation, growth in sales, cash flow and productivity (Fitri, Nugraha, Hakimah, & Manihuruk, 2019). Further, Lee and Yu (2004) concluded in their research that culture influence organizational performance significantly by applying “organizational culture profile (OCP)” applied by the Chatman and Jehn (1994). The OCP consisting of 54 “value statements” likewise risk facing, careful nature, competitive ability, job security, independence, equality, team-based and some others measures that are associated with the performance. However, Lee and Yu (2004) have the opinion that in comparison of the services and manufacturing businesses, association among organizational culture and organizational performance higher in the context of production businesses. On the other hand, during the examination of performance consequences of corporate culture in the context of Singapore, Lee and Yu (2004) concluded that there is a positive association among innovation and cultural strength with regard to the insurance sector. Shahzad, Luqman, Khan, and Shabbir (2012) have the opinion that there is a deep association among organizational performance and management practices that include contribution, independence and creativity. Moreover, Shahzad et al. (2012) extended this argument by indicating that firms having sustained HRM practices perform better as compare to other competitive firms. In accordance with the issue, Fitri et al. (2019) describe that most of the findings are circumstantial related to the association of culture on the organizational performance. However, researchers are paying increasing attention to the evaluation of the association among variables. The cause behind the enhancing admiration of organizational culture the theory that it increases organizational performance financially (Fitri et al., 2000). In prior studies, researchers concluded that organizational culture is a critical factor for organizations with respect to performance but there are limited studies available in the literature that examine the association among these variables. Additionally, organizational culture is found to be significant influential directly or indirectly for organizational performance. This research is an attempt to fill the gap prevailed in literature by studying the moderating impact of organizational culture. By this, this research will contribute to the literature in the way that how organizational culture influence the relation of HR practices, technology and the organizational performance.

H3: Organizational Culture significantly moderate the relationship between human resource capabilities and organizational performance.

H4: Organizational Culture significantly moderate the relationship between technology and organizational performance.

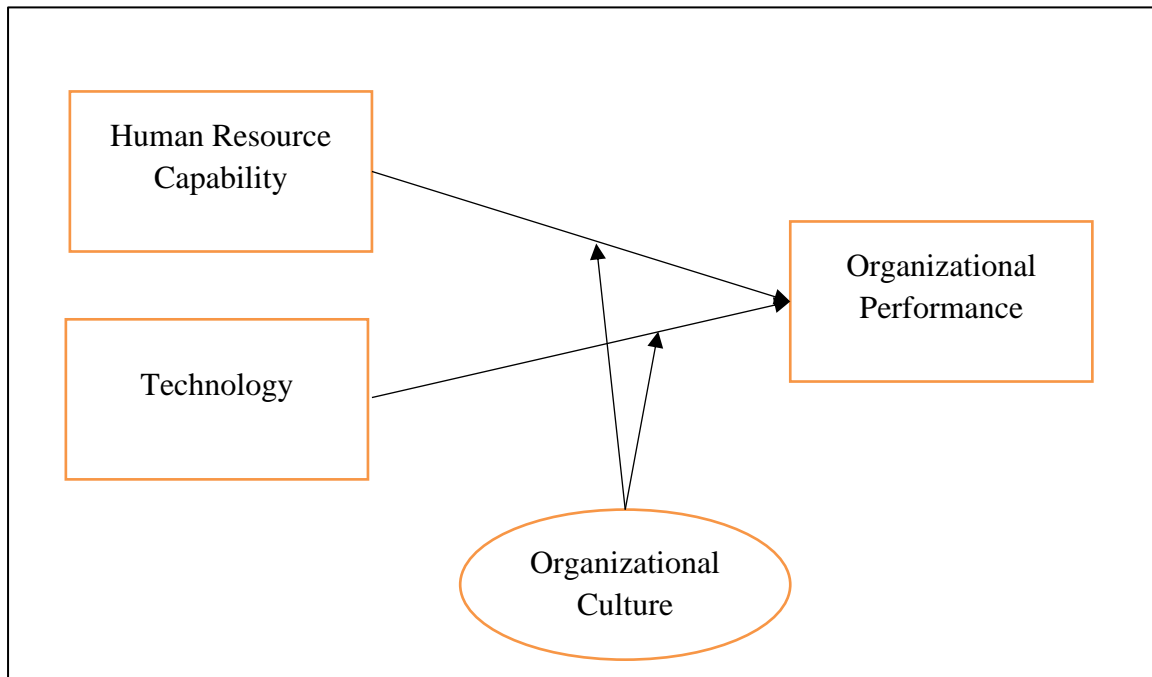

Figure 1. Research Model

Methodology

According to Ary, Jacobs, Irvine, and Walker (2018), population is defined as “all the members of any well-defined class of people, events or objects”. In this study, the targeted population is taken from SMEs of the automotive and metal sector industries in West Java Indonesia. A mono quantitative approach was used to investigate the antecedents of organizational performance. As per the recommendation of Lei and Lomax (2005), for the data analysis the simple size of 100 is appropriate and the sample range 250 to 500 for using SEM analysis. The total number of 370 self-administrative questionnaires have been distributed and 244 valid responses have taken from the respondents. One of the probability sampling technique systematic random sampling has been employed in the present study. The items of the constructs are adopted from the previous literature. Moreover, the items or questions were measured on a seven point Likert scale “ranging from 1 (strongly agree) to 7 (strongly disagree)”. Pre testing as well as post testing have been conducted for the assurance of validity and reliability.

Results

Measurement Model

The outer model (measurement model) and inner model (structural model) are two steps for the assessment of PLS-SEM (Hair, Ringle, & Sarstedt, 2011). In the first step of measurement model assessment, the reliability and validity of the constructs should be measured (Hair Jr, Sarstedt, Hopkins, & Kuppelwieser, 2014). The focal activities have been stressed in the assessment of the measurement model are “indicator reliability, internal consistency reliability, convergent validity and discriminant validity” (Hair et al., 2011; Hair Jr et al., 2014). Furthermore, indicator reliability also known as indicator loadings become acceptable at the

threshold of 0.4 and above (Hair et al., 2011). In addition, the measurement of internal consistency reliability is verified with composite reliability and it should be higher than 0.7 as acceptable value (Hair Jr et al., 2014). Additionally, in the phase of the measurement of the measurement assessment of PLS-SEM, the convergent validity and discriminant validity should be measured (Hair et al., 2011; Hair Jr et al., 2014). Convergent validity is “the evidence of showing that interested measure is related to the rest of the shared measures in the constructs” (Petter & McLean, 2009). Meanwhile, Hair et al. (2011) recommended that the average variance extracted (AVE) for the measurement of the convergent validity and the threshold value should be greater than 0.50. Lastly, the discriminant validity examines “how each item relates to each construct and how strongly is the measured construct relate to the construct it intends to reflect” (Hair et al., 2011; Joe F Hair Jr et al., 2014). According to Hair et al., “discriminant validity is said to be achieved once the square roots of AVE are greater than the inter-factor correlations between constructs, which are under the diagonal cells”. Therefore, the measurement of the heterotrait-monotrait (HTMT) and the heterotrait-monotrait (HTMT) ratio discriminant validity criteria suggested by Henseler et al. (2015) that all the values are below than 0.90.

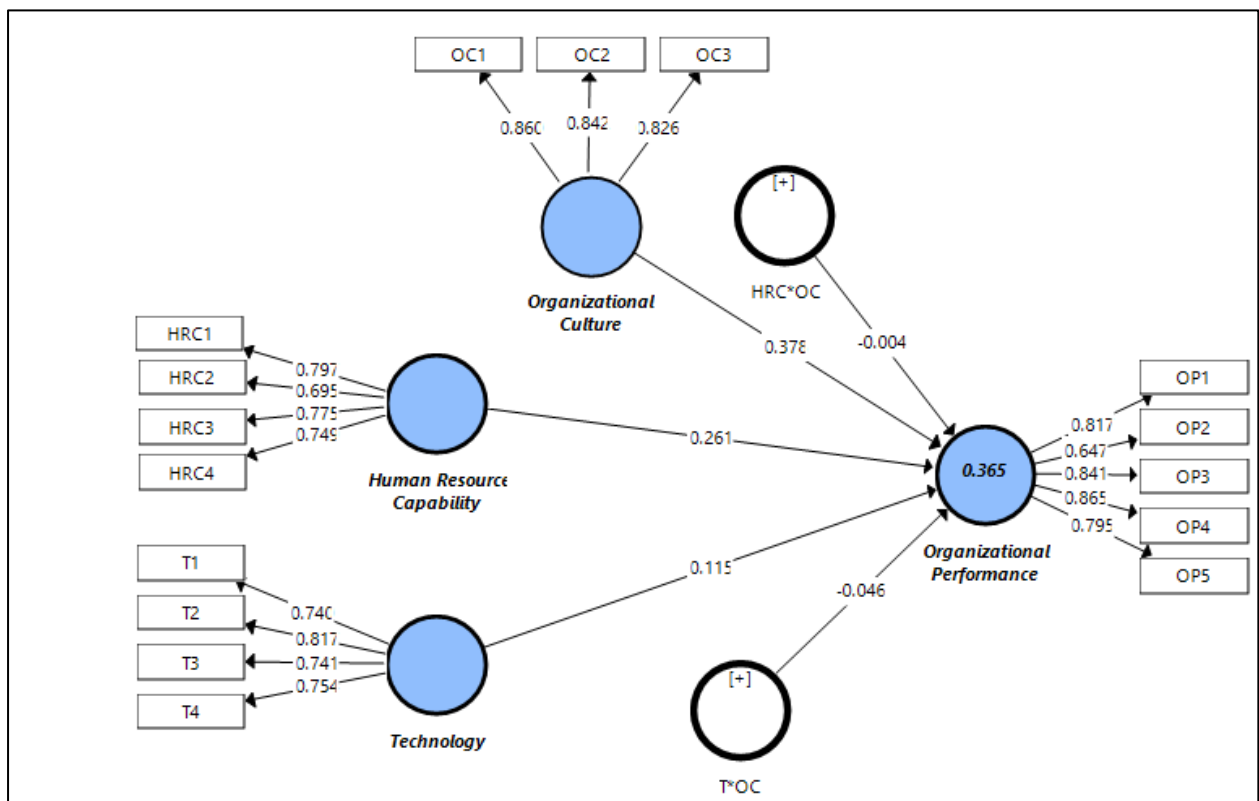

Figure 2. Outer Model (Measurement Model)

Table 1. *Constructs' Validity & Reliability*

	Cronbach's Alpha	rho_A	CR	AVE
Human Resource Capability	0.749	0.762	0.841	0.570
Organizational Culture	0.800	0.816	0.880	0.710
Organizational Performance	0.853	0.853	0.896	0.635
Technology	0.762	0.763	0.848	0.583

Table 2. *Discriminant Validity (Heterotrait-Monotrait Ratio HTMT)*

	HRC	ME1	ME2	OC	OP	Tech.
Human Resource Capability						
Organizational Culture	0.491	0.069	0.115			
Organizational Performance	0.559	0.158	0.048	0.618		
Technology	0.495	0.050	0.033	0.586	0.466	

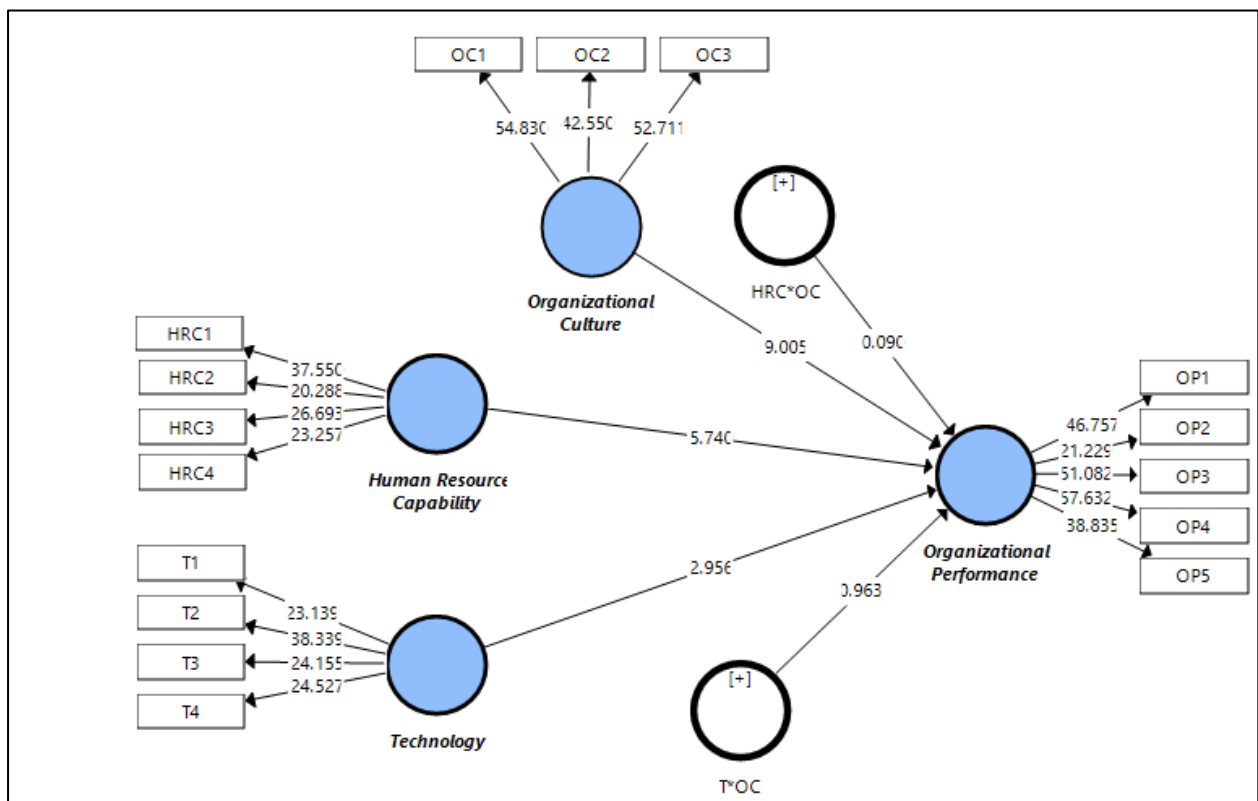

Figure 3. *Inner Model (Structural Model)*

Table 3. *Structural Model Assessment (Direct Results)*

	(β)	(STDEV)	T Statistics	P Values
HRS >> OP	0.261	0.046	5.632	0.000
Tech >> OP	0.115	0.039	2.974	0.000

Table 4. *Structural Model Assessment (Moderation)*

	(β)	(STDEV)	T Statistics	P Values	Decision
HRS*OC -> OP	-0.004	0.045	0.092	0.927	Not Supported
Tech*AF -> OP	-0.046	0.048	0.961	0.336	Not Supported

Structural Model

Once the measurement model was assessed and the conceptual model is reliable and valid. Then the assessment of structural model has been done in the conceptual framework of the existing study. Basically, the assessment of the structural model in PLS-SEM is the establishment of the variance (R^2) (Hair et al., 2011; Hair Jr, Hult, Ringle, & Sarstedt, 2016; Hair Jr et al., 2014). Thus, the bootstrapping technique was used to obtain significance of path coefficient among the exogenous and endogenous variables.

Findings

The first hypothesis anticipated ($\beta=0.241, p<0.05$) that human resource capability has positive and significant impact on organizational performance. The findings of the existing result are consistent with the findings of the prior studies (Karami, 2004). Various human resource capabilities like skill set, innovation, effectiveness, commitment and training are considered motivational factors that leads towards the organizational performance. Additionally, these cannot easily be copied and upgrade the competitiveness within the organization. In addition, the second hypothesis projected ($\beta=0.115, p<0.05$) that technology significantly and positively influence on organizational performance. Several past studies are in line with the findings of the current study (Dennis & Dowsell, 2013; Khan, Masrek, & Nadzar, 2015). Once the technology is limited within the organization then the significant results or findings regarding organizational performance are not taken. With the adoption of technology can increase the competitiveness of the organizational performance. According to Denison (1984), the organizational culture is not considered a strong predictor towards organizational performance. The organizational culture is a short term predictor of organizational performance. Therefore, the Table 4 shows that the organizational culture did not moderates among the relationship of human resource capability, innovation and organizational performance. Additionally, the study conducted by Denison and Mishra (1995) reported that once the human resource capabilities

among the organizations are strong then the impact of organizational culture will be limited. Around the globe the organizations are working to adopt new and latest technologies and implement these technologies within the organization and train their human resource. In addition, these investment i.e. increase in the human resource capabilities and new technology adoption can directly effect on the organizational performance. These can increase the competitiveness of the organization performance.

Limitations and Future Recommendations

Despite the findings of the present research contributes equally theoretically and practically, there are some limitations and future recommendations for the future researchers. In, the existing research the self-administrative questionnaires had been distributed and it is mono quantitative research. So, the future research should be conducted in qualitative as well as mixed mode. The large sample size should be taken in the future researches. The researchers in the developing countries in general and south Asian countries in particular should the existing conceptual framework to conduct research. Various variables like leadership and its types should be investigated on second order in the next researches. Longitudinal research must be conducted rather than cross sectional study. Various other sectors like small medium enterprises (SMEs), large scale enterprises (LMEs), banking sectors, private organizations and several public organizations. Once the sampling frame will not be available then non-probability techniques like convenience sampling and judgmental sampling techniques will be employed.

Conclusion

The aim objective of the contemporary study is to examine the influence of human resource capability and technology on the organizational performance of the industries of Indonesia. Moreover, the present study also planned to investigate the moderating role of organizational culture among the relationship of human resource capability and technology and organizational performance. This study adopted quantities research technique with cross sectional approach to investigate the proposed relationship among the constructs. For the examination of proposed relationship, the data was collected f by using self-administrative questioners. The study found that human resource capability and technology significantly and positively influence the organizational performance in Indonesia. In addition, human resource capability and technology are the strong predictors of organizational performance. Moreover, findings indicated that availability of organizational culture does not significantly moderate the relationship of human resource capability and technology with the organizational performances of SMEs Indonesian. The organizations all over the world whether the private or public should focus on the human resource capabilities like invest to increase the skill set, bring innovation in daily methods, adequate training and development programs can bring significant change within the organization that leads and increase the organizational performance. Likewise, the adoption of new technology timely can also bring a constructive change in the organizations and have huge positive impact on the organizational performance of SMEs in Indonesia.

References

- [1]. Antony, J. P., & Bhattacharyya, S. (2010). Measuring organizational performance and organizational excellence of SMEs–Part 2: an empirical study on SMEs in India. *Measuring Business Excellence*, 14(3), 42.
- [2]. Arthur, J. B., & Boyles, T. (2007). Validating the human resource system structure: A levels-based strategic HRM approach. *Human resource management review*, 17(1), 77-92.
- [3]. Ary, D., Jacobs, L. C., Irvine, C. K. S., & Walker, D. (2018). Introduction to research in education. Cengage Learning.
- [4]. Barney, J. (1991a). Firm resources and sustained competitive advantage. *Journal of management*, 17(1), 99-120.
- [5]. Barney, J. (1991b). Special theory forum the resource-based model of the firm: origins, implications, and prospects. *Journal of Management*, 17(1), 97-98.
- [6]. Bhatnagar, J. (2007). Predictors of organizational commitment in India: strategic HR roles, organizational learning capability and psychological empowerment. *The International Journal of Human Resource Management*, 18(10), 1782-1811.
- [7]. Bhatnagar, J., & Sharma, A. (2005). The Indian perspective of strategic HR roles and organizational learning capability. *The International Journal of Human Resource Management*, 16(9), 1711-1739.
- [8]. Bhatt, G. D. (2000). Organizing knowledge in the knowledge development cycle. *Journal of Knowledge Management*, 4(1), 15-26.
- [9]. Boons, F., Montalvo, C., Quist, J., & Wagner, M. (2013). Sustainable innovation, business models and economic performance: an overview. *Journal of cleaner production*, 45, 1-8.
- [10]. Boselie, P., Paauwe, J., & Jansen, P. (2001). Human resource management and performance: lessons from the Netherlands. *International Journal of Human Resource Management*, 12(7), 1107-1125.
- [11]. Brockbank, W., Ulrich, D., Younger, J., & Ulrich, M. (2012). Recent study shows impact of HR competencies on business performance. *Employment Relations Today*, 1(39), 1-7.
- [12]. Carmeli, A., & Tishler, A. (2004). The relationships between intangible organizational elements and organizational performance. *Strategic management journal*, 25(13), 1257-1278.
- [13]. Chang, W.-J. A., & Huang, T. C. (2010). The impact of human resource capabilities on internal customer satisfaction and organisational effectiveness. *Total Quality Management*, 21(6), 633-648.
- [14]. Chatman, J. A., & Jehn, K. A. (1994). Assessing the relationship between industry characteristics and organizational culture: how different can you be? *Academy of management Journal*, 37(3), 522-553.
- [15]. Chitrao, P. V. (2015). Strategic HR for sustainable business in technology driven 21st C. *Indian Journal of Science and Technology*, 8, 69.
- [16]. Combs, J. G., Crook, T. R., & Shook, C. L. (2005). The dimensionality of organizational performance and its implications for strategic management research. *Research methodology in strategy and management*, 2(5), 259-286.
- [17]. Dao, V., Langella, I., & Carbo, J. (2011). From green to sustainability: Information Technology and an integrated sustainability framework. *The Journal of Strategic Information Systems*, 20(1), 63-79.
- [18]. Demirbag, M., Tatoglu, E., Tekinkus, M., & Zaim, S. (2006). An analysis of the relationship between TQM implementation and organizational performance: evidence from Turkish SMEs. *Journal of Manufacturing Technology Management*, 17(6), 829-847.
- [19]. Denison, D. R. (1984). Bringing corporate culture to the bottom line. *Organizational dynamics*, 13(2), 5-22.
- [20]. Denison, D. R., & Mishra, A. K. (1995). Toward a theory of organizational culture and effectiveness. *Organization science*, 6(2), 204-223.
- [21]. Dennis, C. L., & Dowswell, T. (2013). Psychosocial and psychological interventions for preventing postpartum depression. *Cochrane database of systematic reviews*, (2).
- [22]. Enkel, E., Rosenø, A., & Mezger, F. (2012). *Dynamic capabilities for new business creation: A cross-industry study*. Paper presented at the ISPIM Conference Proceedings.

- [23]. Fernando, Y., Jabbour, C. J. C., & Wah, W.-X. (2019). Pursuing green growth in technology firms through the connections between environmental innovation and sustainable business performance: does service capability matter? *Resources, conservation and recycling*, 141, 8-20.
- [24]. Fishbein, M. (1981). Icek Ajzen (1975), Belief, Attitude, Intention, and Behavior: An Introduction to Theory and Research. *Reading, MA: Addison-Wesley*.
- [25]. Fitri, H., Nugraha, A. T., Hakimah, Y., & Manihuruk, C. (2019). Strategic Management of Organizational Knowledge and Competency Through Intellectual Capital. *Polish Journal of Management Studies*, 19(2), 132-141.
- [26]. Garg, B. (2014). Human resource-driving force of sustainable business practices. *International Journal of Innovative Research & Development*, Forthcoming.
- [27]. Gordon, G. G., & DiTomaso, N. (1992). Predicting corporate performance from organizational culture. *Journal of management studies*, 29(6), 783-798.
- [28]. Hair, J. F., Ringle, C. M., & Sarstedt, M. (2011). PLS-SEM: Indeed a silver bullet. *Journal of Marketing theory and Practice*, 19(2), 139-152.
- [29]. Hair Jr, J. F., Hult, G. T. M., Ringle, C., & Sarstedt, M. (2016). *A primer on partial least squares structural equation modeling (PLS-SEM)*: Sage publications.
- [30]. Hair Jr, J. F., Sarstedt, M., Hopkins, L., & Kuppelwieser, V. G. (2014). Partial least squares structural equation modeling (PLS-SEM). *European Business Review*, 26(2), 106-121.
- [31]. Hakimah, Y., Nugraha, A. T., Fitri, H., Manihuruk, C., & Hasibuan, M. (2019). Role Budget Participation and Budget Slack on Supply Chain Operational Performance: Evidence from Indonesian Textile Industry. *International Journal of Supply Chain Management*, 8(3), 10-22.
- [32]. Haseeb, M., Hussain, H. I., Kot, S., Androniceanu, A., & Jermisittiparsert, K. (2019). Role of social and technological challenges in achieving a sustainable competitive advantage and sustainable business performance. *Sustainability*, 11(14), 3811.
- [33]. Hollen, R. M., Van Den Bosch, F. A., & Volberda, H. W. (2013). The role of management innovation in enabling technological process innovation: An inter-organizational perspective. *European Management Review*, 10(1), 35-50.
- [34]. Jain, D. M., & Khurana, R. (2016). A framework to study vendors' contribution in a client vendor relationship in information technology service outsourcing in India. *Benchmarking: an international journal*.
- [35]. Jing, F. F., & Avery, G. C. (2008). Missing links in understanding the relationship between leadership and organizational performance. *International Business & Economics Research Journal (IBER)*, 7(5).
- [36]. Jusoh, R., Ibrahim, D. N., & Zainuddin, Y. (2008). The performance consequence of multiple performance measures usage. *International Journal of Productivity and Performance Management*, 57(2), 119+-136.
- [37]. Karami, E. H. E. A. (2004). The Effectiveness of Selected Human Resources Management Practices on Organisational Performance and Objectives (A Case Study of the Libyan Iron and Steel Company): UK.
- [38]. Khan, A., Masrek, M. N., & Nadzar, F. M. (2015). Analysis of competencies, job satisfaction and organizational commitment as indicators of job performance: A conceptual framework. *Education for Information*, 31(3), 125-141.
- [39]. Khandekar, A., & Sharma, A. (2006). Organizational learning and performance: Understanding Indian scenario in present global context. *Education+ Training*, 48(8-9), 682-692.
- [40]. Komnencic, B., & Pokrajcic, D. (2012). Intellectual capital and corporate performance of MNCs in Serbia. *Journal of Intellectual Capital*, 13(1), 106-119.
- [41]. Kousar, S., Zafar, M., Sabir, S. A., & Sajjad, A. (2019). A Step toward Realization of Vision 2030; Reduction in Child Mortality: New Evidence from South Asian Countries. *Journal of Independent Studies & Research: Management & Social Sciences & Economics*, 17(1).
- [42]. Lee, S. K. J., & Yu, K. (2004). Corporate culture and organizational performance. *Journal of Managerial Psychology*, 19(4), 340-359.
- [43]. Lee, S. H., Phan, P. H., & Chan, E. (2005). The impact of HR configuration on firm performance in Singapore: a resource-based explanation. *The International Journal of Human Resource Management*, 16(9), 1740-1758.

- [44]. Lopez-Cabrales, A., Pérez-Luño, A., & Cabrera, R. V. (2009). Knowledge as a mediator between HRM practices and innovative activity. *Human Resource Management: Published in Cooperation with the School of Business Administration, The University of Michigan and in alliance with the Society of Human Resources Management*, 48(4), 485-503.
- [45]. Mabey, C., Salaman, G., & Storey, J. (1998). *Human resource management: A strategic introduction*: Blackwell Publishing.
- [46]. Maditinos, D., Chatzoudes, D., Tsairidis, C., & Theriou, G. (2011). The impact of intellectual capital on firms' market value and financial performance. *Journal of Intellectual Capital*, 12(1), 132-151.
- [47]. Mahadeo, J. D., Soobaroyen, T., & Hanuman, V. O. (2012). Board composition and financial performance: Uncovering the effects of diversity in an emerging economy. *Journal of business ethics*, 105(3), 375-388.
- [48]. Maritan, C. A. (2001). Capital investment as investing in organizational capabilities: An empirically grounded process model. *Academy of management Journal*, 44(3), 513-531.
- [49]. Masnita, Y., Yakub, A., Nugraha, A. T., & Riorini, S. V. (2019). Influence of Government Support, Technology Support and Islamic Banking awareness on Islamic Banking Choice in Indonesia with Moderating Role of Religiosity. *International Journal of Innovation, Creativity and Change*, 6(8), 46-66.
- [50]. Moeller, K. (2009). Intangible and financial performance: causes and effects. *Journal of Intellectual Capital*, 10(2), 224-245.
- [51]. Monday, J. U. (2015). Local content policy, human capital development and sustainable business performance in the Nigerian oil and gas industry. *J. Mgmt. & Sustainability*, 5, 75.
- [52]. Nugraha, A. T., & Hakimah, Y. (2019). Role of Relational Capabilities on the Supply Chain Performance of Indonesian Textile Sector with Moderating Effect of Technology Adoption. *International Journal of Supply Chain Management*, 8(5), 509-522.
- [53]. Parast, M. M., & Adams, S. G. (2012). Corporate social responsibility, benchmarking, and organizational performance in the petroleum industry: A quality management perspective. *International Journal of Production Economics*, 139(2), 447-458.
- [54]. Patel, P. C., Messersmith, J. G., & Lepak, D. P. (2013). Walking the tightrope: An assessment of the relationship between high-performance work systems and organizational ambidexterity. *Academy of management Journal*, 56(5), 1420-1442.
- [55]. Petter, S., & McLean, E. R. (2009). A meta-analytic assessment of the DeLone and McLean IS success model: An examination of IS success at the individual level. *Information & Management*, 46(3), 159-166.
- [56]. Richard, O. C., & Johnson, N. B. (2001). Strategic human resource management effectiveness and firm performance. *International Journal of Human Resource Management*, 12(2), 299-310.
- [57]. Rosenbusch, N., Brinckmann, J., & Müller, V. (2013). Does acquiring venture capital pay off for the funded firms? A meta-analysis on the relationship between venture capital investment and funded firm financial performance. *Journal of business venturing*, 28(3), 335-353.
- [58]. Saa-Perez, P. D., & Garcia-Falcon, J. M. (2002). A resource-based view of human resource management and organizational capabilities development. *International Journal of Human Resource Management*, 13(1), 123-140.
- [59]. Schuler, R. S., Jackson, S. E., Jackofsky, E., & Slocum Jr, J. W. (1996). Managing human resources in Mexico: A cultural understanding. *Business Horizons*, 39(3), 55-61.
- [60]. Shahzad, F., Luqman, R. A., Khan, A. R., & Shabbir, L. (2012). Impact of organizational culture on organizational performance: An overview. *Interdisciplinary Journal of Contemporary Research in Business*, 3(9), 975-985.
- [61]. Simon, M., & Shallone, C. K. (2013). Effects of firm size and market structures in technological innovation: a review of literature. *Journal of Sustainable Development Studies*, 2(2).
- [62]. Snell, A. (2011). Developing talent intelligence to boost business performance. *Strategic HR Review*, 10(2), 12-17.
- [63]. Teo, H.-H., Wei, K. K., & Benbasat, I. (2003). Predicting intention to adopt interorganizational linkages: An institutional perspective. *MIS quarterly*, 19-49.

- [64]. Thatcher, S. M., Foster, W., & Zhu, L. (2006). B2B e-commerce adoption decisions in Taiwan: The interaction of cultural and other institutional factors. *Electronic commerce research and applications*, 5(2), 92-104.
- [65]. Tsui, A. S. (1987). Defining the activities and effectiveness of the human resource department: A multiple constituency approach. *Human Resource Management*, 26(1), 35-69.
- [66]. Ulrich, D., Younger, J., Brockbank, W., & Ulrich, M. (2012). HR talent and the new HR competencies. *Strategic HR Review*, 11(4), 217-222.
- [67]. Venkatesh, V., & Bala, H. (2008). Technology acceptance model 3 and a research agenda on interventions. *Decision Sciences*, 39(2), 273-315.
- [68]. Venkatesh, V., Thong, J. Y., & Xu, X. (2012). Consumer acceptance and use of information technology: extending the unified theory of acceptance and use of technology. *MIS quarterly*, 157-178.
- [69]. Vlachos, I. (2008). The effect of human resource practices on organizational performance: evidence from Greece. *The International Journal of Human Resource Management*, 19(1), 74-97.
- [70]. Wirtenberg, J., Lipsky, D., Abrams, L., Conway, M., & Slepian, J. (2007). The future of organization development: Enabling sustainable business performance through people. *Organization Development Journal*, 25(2), P11.
- [71]. Wright, P. M., Gardner, T. M., & Moynihan, L. M. (2003). The impact of HR practices on the performance of business units. *Human resource management journal*, 13(3), 21-36.
- [72]. Wright, P. M., & Kehoe, R. R. (2008). Human resource practices and organizational commitment: A deeper examination. *Asia Pacific Journal of Human Resources*, 46(1), 6-20.
- [73]. Zack, M., McKeen, J., & Singh, S. (2009). Knowledge management and organizational performance: an exploratory analysis. *Journal of Knowledge Management*, 13(6), 392-409.
- [74]. Zafar, M., Kousar, S., & Sabir, S. A. (2019). Impact of Globalization on Green Growth: A Case of OECD Countries. *Journal of Indian Studies*, 5(2), 231-244.

urce_Capability_and_Technology_on_Organizational_performan.

ORIGINALITY REPORT

0%

SIMILARITY INDEX

0%

INTERNET SOURCES

0%

PUBLICATIONS

%

STUDENT PAPERS

PRIMARY SOURCES

Exclude quotes On

Exclude bibliography On

Exclude matches < 2%