

# Tuning of PID Controller Using Open Loop On Off Method and Closed Loop Dynamic Simulation in a 10 L Mixing Tank

*by Yulius Deddy Hermawan*

---

**Submission date:** 08-Jun-2021 02:52PM (UTC+0700)

**Submission ID:** 1602718333

**File name:** hermawanCES101-104-2018.pdf (1.12M)

**Word count:** 4282

**Character count:** 21347

## **Tuning of PID Controller Using Open Loop On Off Method and Closed Loop Dynamic Simulation in a 10 L Mixing Tank**

**Yulius Deddy Hermawan and Mitha Puspitasari**

Department of Chemical Engineering, Faculty of Industrial Engineering  
Universitas Pembangunan Nasional "Veteran" Yogyakarta  
Jl. SWK 104 (Lingkar Utara) Condongcatur Yogyakarta 55283 Indonesia

Copyright © 2018 Yulius Deddy Hermawan and Mitha Puspitasari. This article is distributed under the Creative Commons Attribution License, which permits unrestricted use, distribution, and reproduction in any medium, provided the original work is properly cited.

### **Abstract**

The open loop on off experiment for tuning of Proportional Integral Derivative (PID) controller in a 10 L mixing tank has been successfully done in laboratory. A 10 L tank was designed for mixing of salt solution (as a stream-1) and water (as a stream-2). An electric stirrer was used to achieve uniform characteristic in tank. The tank system was designed overflow to keep its volume constant. The two configurations of composition control in a mixing tank have been proposed; they are Configuration-1 and Configuration-2. Stream-1 and stream-2 were chosen as manipulated variables for Configuration-1 and Configuration-2, respectively. In the open loop on-off experiment, the valve of each manipulated variable was suddenly fully open (on position) for several seconds and then fully closed (off position) for several seconds. The on off response of salt concentration in tank to on off input change in manipulated variable has been investigated. The resulted on off curves were then used to determine the PID parameters. This experiment gave the controller gain  $K_c$  [ $\text{m}^2/(\text{g}\cdot\text{sec})$ ] for Configuration-1 and Configuration-2 are 68790 and  $-61146$ , respectively. The integral and derivative time constants for both configurations are the same, i.e.  $\tau_i = 80$  seconds,  $\tau_D = 19$  seconds. In order to evaluate the resulted tuning parameters, closed loop dynamic simulation using computer was also done. The mathematical model of composition control in a mixing tank was numerically solved and rigorously examined in Scilab environment. The closed loop dynamic simulation revealed that PID controller acted very well and its responses were faster than those in P and PI controllers.

**Keywords:** Closed loop, mixing tank, on off, open loop, PID, tuning

## 1 Introduction

The mixing processes are often met in industries such as blending, dilution, and reaction processes. Composition uniformity in the tank is a success key for mixing or chemical reaction processes. However, the composition in the tank is not at static value but it is dynamic due to the input disturbance changes to the process. Therefore, the composition control must be implemented to maintain its composition constant at its desired value [14].

Tuning of Proportional Integral Derivative (PID) control parameters such as proportional gain ( $K_c$ ), integral time constant ( $\tau_I$ ), and derivative time constant ( $\tau_D$ ) is an important activity that should be done before running the plant automatically. Since the PID control parameters seriously affect the stability of the plant, they should be tuned properly [4]. Therefore, study on controller tuning, dynamic simulation and control are very important to be done.

Some researches on controller tuning, process dynamic and control have been done previously. Shamsuzzohaa et al [5] have studied on-line PI controller tuning using closed-loop setpoint response. Dharan et al [8] has proposed the optimization techniques for tuning of PID controller in a Multi-Input-Multi-Output (MIMO) process. Hermawan [13] implemented the Process Reaction Curve (PRC) for tuning of temperature controller parameters in a 10 L stirred tank heater. Hermawan and Haryono [14] also implemented the PRC for tuning of composition controller parameters in a 10 L mixing tank. Recently, Dalen and Ruscio [2] proposed a semi-heuristic PRC for tuning of PID.

Hermawan et al [12] utilized Routh-Hurwitz (RH) stability criteria to predict PI parameters in flow control system with pump's voltage as a manipulated variable. Hermawan et al [15] have also used RH stability criteria to predict P parameter of level control in a pure capacitive tank. Rao et al [3] have proposed design of PID controller for pure integrator system with time delay. Recently, Álvaro et al. [6] utilized Xcos software to simulate the level control in the interacting tank system.

This work was aimed to propose two composition control configurations in a 10 L mixing tank, and to use the open loop on off method for tuning of composition control parameters (PID control parameters). The open loop on off method for tuning of PID control parameters was done experimentally in laboratory instead of the relay feedback testing (RFT). The resulted PID control parameters of the proposed configurations were then examined through dynamic simulation. In order to achieve our goals, this work was done in 2 parts, i.e. open loop experiment in laboratory for tuning of PID control parameters and closed loop simulation using computer programming to examine the resulted PID control parameters and to explore the dynamic

behavior of the proposed composition control configurations. The developed mathematical model was solved numerically with easiest way of explicit euler. The scilab software was used to carry out the closed loop dynamic simulation [7].

## 2 Material and Method

**Figure 1** shows the experimental apparatus setup. Tank No. 1 in **Figure 1** is the main tank that represents a 10 L mixing tank. The mixing tank has 2 input streams (Stream-1 and Stream-2) and 1 output stream (Stream-3). Stream-1 is a salt solution with its volumetric flowrate  $f_1(t)$  [ml/second] and salt concentration  $c_1(t)$  [g/ml] and Stream-2 is water with its volumetric flowrate  $f_2(t)$  [ml/second]. The volumetric flowrates of Stream-1 and Stream-2 can be adjusted by valve No. 7b and 7a, respectively. Stream-3 has volumetric flowrate  $f_3(t)$  [ml/second] and salt concentration  $c_3(t)$  [g/ml]. The salt concentration is measured by means of conductivity-meter. In order to keep the liquid volume in tank constant, the mixing tank is designed overflow. A stirrer is employed to achieve uniform concentration in tank. In normal condition, Stream-1 and Stream-2 come from tanks No. 2a and 3, respectively. If we want to give a concentration disturbance of Stream-1, the tank No. 2b is utilized. The input concentration disturbance can be made by revolving the gate of three-way-valve No. 9, so that Stream-1 comes from the tank No. 2b which is specifically prepared for making concentration disturbance.

The material balance of the mixing tank can be written as follows:

$$\frac{dc_3(t)}{dt} = (f_1(t)c_1(t) - f_1(t)c_3(t) - f_2(t)c_3(t))/V \quad (1)$$

In this work, the 2 composition control configurations are proposed, i.e. Configuration-1 and Configuration-2 as shown in **Figure 2**. Stream-1 and Stream-2 are chosen as manipulated variables (MVs) to control salt concentration in tank ( $c_3$ ) constant at its set point for Configuration-1 and Configuration-2, respectively. The open loop on off experiment for tuning of PID parameters is done for either configurations by changing the opening valve of Stream-1 (No. 7b in **Figure 1**) or Stream-2 (No. 7a in **Figure 1**) to fully open (on position) or fully closed (off position) for several seconds. The output concentration ( $c_3$ ) response to an on off change in input volumetric rate is then investigated. The resulted on off response is then used to determine ultimate period ( $T_u$ ), relay's height ( $h$ ), and maximum amplitude of controlled variable ( $a$ ). Ultimate gain ( $K_u$ ) can be calculated as follows:

$$K_u = \frac{4h}{a\pi} \quad (2)$$

PID parameters are then tuned using Ziegler-Nichols model as shown in **Table 1** [10].

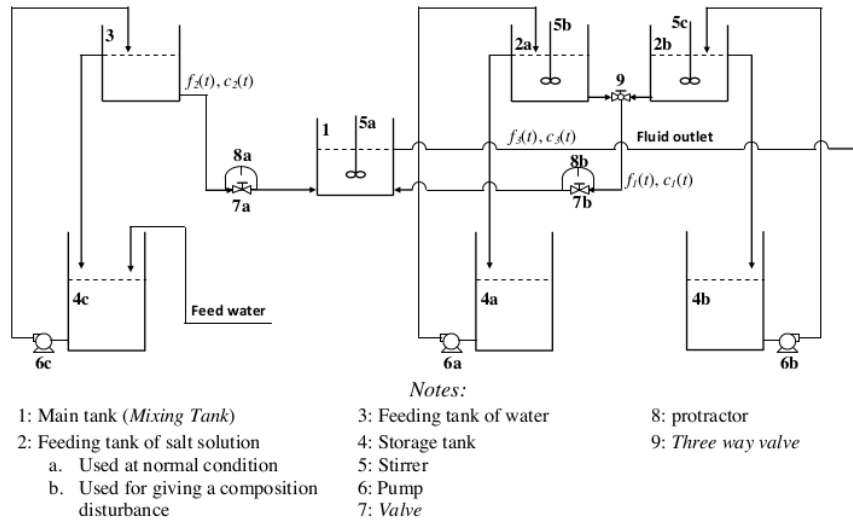

Figure 1. The experimental apparatus setup.

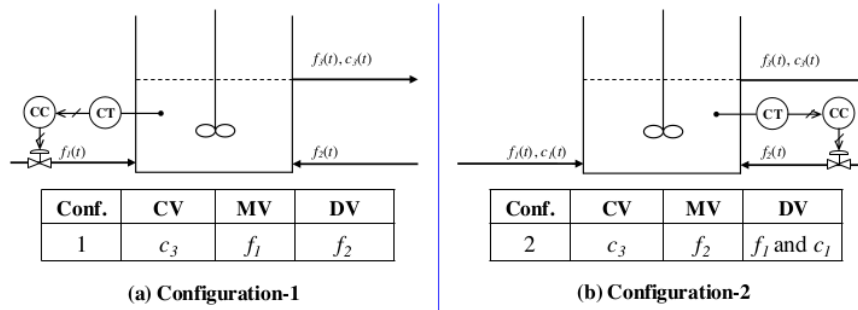

Figure 2. Composition control configurations.

Table 1. Ziegler-Nichols model for tuning of PID control parameters

Controller	$K_c$	$\tau$	$\tau_D$
P	$\frac{Ku}{2}$	-	-
PI	$\frac{2Ku}{5}$	$\frac{4Tu}{5}$	-
PID	$\frac{3Ku}{5}$	$\frac{Tu}{2}$	$\frac{3Tu}{25}$

The resulted PID control parameters are then evaluated through closed loop dynamic simulation using computer programming. The equations of manipulated variables for both configurations are as follows:

Configuration-1:

$$f_1(t) = \bar{f}_1 + K_c e(t) + \frac{K_c}{\tau_I} \int e(t) dt + K_c \tau_D \frac{de(t)}{dt} \quad (3)$$

Configuration-2:

$$f_2(t) = \bar{f}_2 + K_c e(t) + \frac{K_c}{\tau_I} \int e(t) dt + K_c \tau_D \frac{de(t)}{dt} \quad (4)$$

Error ( $e$ ) can defined as follow:

$$e(t) = \bar{c}_3 - c_3(t) \quad (5)$$

Dynamic performance of the composition control system will be formulated from the complete closed loop response, from time  $t = 0$  until steady state has been reached. Integral of the absolute value of the error (IAE) for composition controller would be used for the formulation of the composition dynamic performance. The equation of IAE is then calculated as bellows [9]:

$$IAE = \int_0^{\infty} e(t) dt \quad (6)$$

The mathematic equation system is solved numerically with the easiest way, i.e. Explicit Euler. The free software Scilab [7] is utilized to carry out the closed loop dynamic simulation. The closed loop responses of composition control in a 10 L mixing tank will then be explored in this work.

### 3 Result and Discussion

Steady state parameters of mixing tank system are shown in **Table 2**. According to those steady state parameters, the process time constant is found to be 61.7 seconds (1.03 minutes). The system is therefore considered quiet sensitive to the input disturbance changes.

**Table 2.** Steady state parameters

No	Variable	Value
1	Input salt solution flowrate; $f_1$ [ml/second]	96.3
2	Input water flowrate; $f_2$ [ml/second]	75.7
3	Output salt solution flowrate; $f_3$ [ml/second]	172.0
4	Input salt concentration; $c_1$ [gr/ml]	0.0050
5	Output salt concentration; $c_3$ [gr/ml]	0.0028
6	Salt solution volumen in tank; $V$ [ml]	10613

The open loop on off responses resulted from laboratory investigation are shown in **Figure 3**. The ultimate gains ( $K_u$ ) for Configuration-1 and Configuration-2 are found to be 114650 and 101911, respectively. Ultimate periods ( $T_u$ ) for both configu-

rations are the same, it is 160 seconds. The resulted  $K_u$  and  $T_u$  are then used to calculate PID control parameters as shown in **Table 3**.

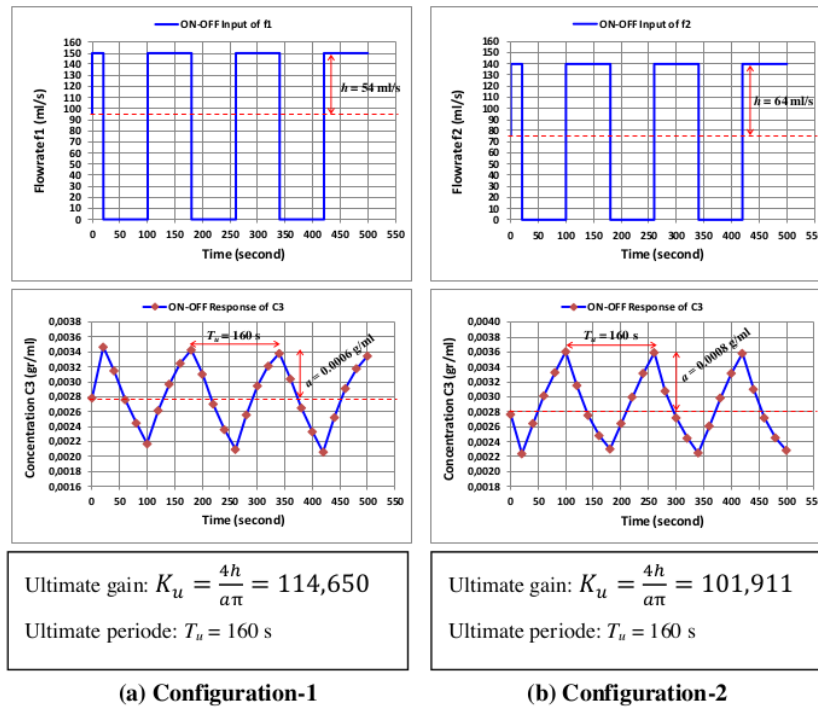

**Figure 3.** Open loop on-off responses: (a) Configuration-1, (b) Configuration-2

**Table 3.** Tuning results of PID controller parameters

Type of Feedback Control	Proportional Gain $K_c$ [ml <sup>2</sup> /(g.second)]		Integral Time Constant $\tau$ [second]		Derivative Time Constant $\tau_D$ [second]				
	$K_c$	Conf-1	Conf-2	$\tau$	Conf-1	Conf-2	$\tau_D$	Conf-1	Conf-2
P	$\frac{K_u}{2}$	57325	-50955	-	-	-	-	-	-
PI	$\frac{2 K_u}{5}$	45860	-40764	$\frac{4 T_u}{5}$	128	128	-	-	-
PID	$\frac{3 K_u}{5}$	68790	-61146	$\frac{T_u}{2}$	80	80	$\frac{3 T_u}{2.5}$	19	19

In Configuration-1 and Configuration-2, salt concentration in tank ( $c_3$ ) is kept constant at its *set point*,  $c_3^{SP}=0.0028$  g/ml, by manipulating the input salt solution flowrate ( $f_1$ ) and the input water flowrate ( $f_2$ ), respectively. Controller acting of Configuration-1 is *reverse acting*, where if the controlled variable of  $c_3$  *increases* from its set point, the controller attempts to return  $c_3$  to its set point by *decreasing* the manipulated variable of  $f_1$ . Therefore, controller gain ( $K_c$ ) value of

Configuration-1 is *positive*. And vice versa, controller acting of Configuration-2 is *direct acting*, where if controlled variable of  $c_3$  increases, the controller attempts to return  $c_3$  to its set point by *increasing* the manipulated variable of  $f_2$ . Controller gain ( $K_c$ ) value of Configuration-2 with *direct acting* is thus *negative* [1], [11].

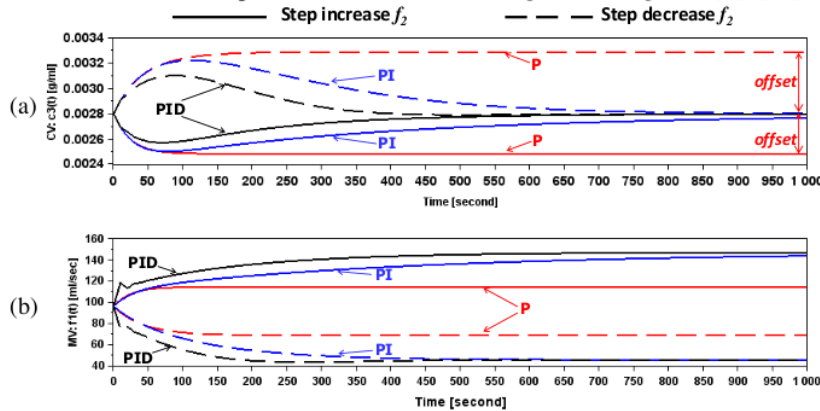

**Figure 4.** Closed loop responses of Configuration-1 to step input changes in  $f_2(t)$  with  $\Delta f_2 = \pm 40$  ml/sec: (a)  $CV=c_3(t)$ , (b)  $MV=f_1(t)$ .

**Table 4.** Closed loop performances of Configuration-1 to step input changes  $f_2$

Type of Feedback Control	Step increase $f_2$ with $\Delta f_2 = +40$ ml/s	Step decrease $f_2$ with $\Delta f_2 = -40$ ml/s	IAE	Offset [gr/ml]
P	0.6230	-0.0003	0.9542	0.0005
PI	0.1407	0.0000	0.1421	0.0000
<b>PID</b>	<b>0.0592</b>	<b>0.0000</b>	<b>0.0621</b>	<b>0.0000</b>

The closed loop dynamic simulation is done to examine the robustness of the resulted PID control parameters in **Table 3**. The closed loop responses of Configuration-1 to step input changes in the input water flowrate ( $f_2$ ) are illustrated in **Figure 4**. While the closed loop performances of Configuration-1 are listed in **Table 4**. The disturbances are made by following both functions of step increase and step decrease. For step increase of  $f_2$ , flowrate of  $f_2$  is increased immediately by an amount of +40 ml/s. The solid line in **Figure 4** represents the closed loop responses to a step increase change in  $f_2$ . The salt concentration in tank ( $c_3$ ) decreases with increasing of the input water flowrate ( $f_2$ ); the controller then attempts to return  $c_3$  to its set point by increasing the manipulated variable of  $f_1$ . As can be seen in **Figure 4**, P-Control produces an offset of  $-0.0003$  g/ml. Combination of proportional and integral control modes leads to eliminate an offset [4], [14]. PI and PID-Controls are able to return  $c_3$  to its set point. Closed loop response of PID-Control is fastest compared with P and PI-Controls; concentration  $c_3$  can be returned to its set point at time about 900 seconds.



The dashed line in **Figure 4** represents the closed loop responses to a step decrease change in  $f_2$ . The concentration  $c_3$  increases first, and then drops to its set point. P Control still results an offset of 0.0005 g/ml. The closed loop response of PID-Control is the fastest one compared with P and PI-Controls; the set point of  $c_3$  can be obtained at time about 800 seconds.

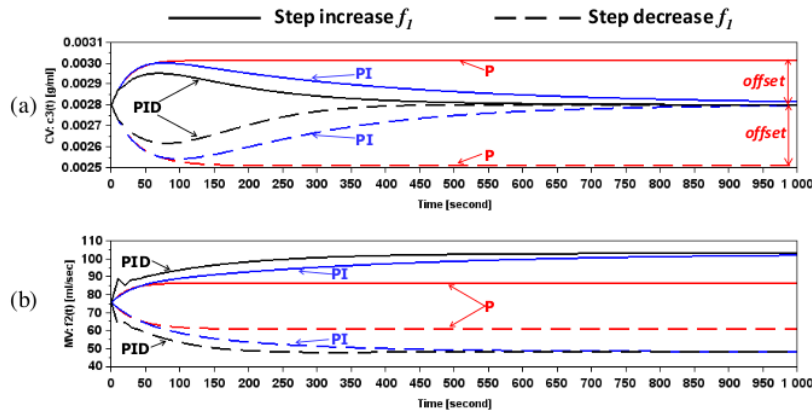

**Figure 5.** Closed loop responses of Configuration-2 to step input changes in  $f_1(t)$  with  $\Delta f_1 = \pm 35$  ml/sec: (a)  $CV = c_3(t)$ , (b)  $MV = f_2(t)$ .

**Table 5.** Closed loop performances of Configuration-2 to step input changes  $f_1$

Type of Feedback Control	Step increase $f_1$ with $\Delta f_1 = +35$ ml/s		Step decrease $f_1$ with $\Delta f_1 = -35$ ml/s	
	IAE	Offset [gr/ml]	IAE	Offset [gr/ml]
P	0.4231	0.0002	0.5725	-0.0003
PI	0.0860	0.0000	0.0863	0.0000
<b>PID</b>	<b>0.0360</b>	<b>0.0000</b>	<b>0.0364</b>	<b>0.0000</b>

**Figure 5** shows the closed loop responses of Configuration-2 to step input changes in the input salt solution flowrate ( $f_1$ ). Whereas the closed loop performances of Configuration-2 to step input changes  $f_1$  are listed in **Table 5**. The disturbances are made by following both functions of step increase and step decrease of the input salt solution flowrate ( $f_1$ ). For step increase of  $f_1$ , flowrate of  $f_1$  is increased immediately by an amount of +35 ml/s. The solid line in **Figure 5** represents the closed loop responses of Configuration-2 to a step increase change in  $f_1$ . The salt concentration in tank ( $c_3$ ) increases with increasing of the input salt solution flowrate ( $f_1$ ); then, the controller attempts to back  $c_3$  to its set point by increasing the manipulated variable of the input water flowrate ( $f_2$ ). Again, as shown in **Figure 5**, P-Control results an offset of 0.0002 g/ml. But, PI and PID-Controls can return the concentration of  $c_3$  to its set point of 0.0028 g/ml. PID-Control gives the fastest responses compared with P and PI-Controls; the concentration of  $c_3$  can be returned to its set point at time about 800 seconds.

The dashed line in **Figure 5** represents the closed loop responses of Configuration-2 to a step decrease change in the input disturbance of  $f_1$ . The concentration  $c_3$  decreases with decreasing of flowrate  $f_1$ . P-Control still produces an offset of  $-0.0003$  g/ml. Both PI and PID-Controls are able to eliminate an offset, i.e. concentration  $c_3$  can be kept constant at its set point of  $0.0028$  g/ml. Again, PID-Control produces the fastest response compared with P and PI-Controls; the controlled variable of  $c_3$  can be returned to its set point at time about 500 seconds.

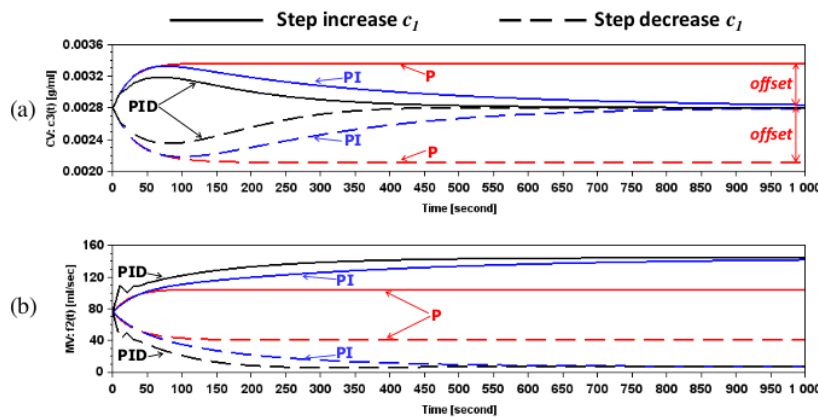

**Figure 6.** Closed loop responses of Configuration-2 to step input changes in  $c_1(t)$  with  $\Delta c_1 = \pm 0.002$  ml/sec: (a)  $CV=c_3(t)$ , (b)  $MV=f_2(t)$ .

**Table 6.** Closed loop performances of Configuration-2 to step input changes  $c_1$

Type of Feedback Control	Step increase $c_1$ with $\Delta c_1 = +0.002$ g/ml	Step decrease $c_1$ with $\Delta c_1 = -0.002$ g/ml		
	IAE	Offset [gr/ml]	IAE	Offset [gr/ml]
P	1.1111	0.0006	1.3572	-0.0007
PI	0.2151	0.0000	0.2160	0.0000
<b>PID</b>	<b>0.0900</b>	<b>0.0000</b>	<b>0.0914</b>	<b>0.0000</b>

The closed loop responses of Configuration-2 to step input changes in the input salt concentration ( $c_1$ ) are shown in **Figure 6**. While the closed loop performances of Configuration-2 to step input changes in  $c_1$  are listed in **Table 6**. The disturbances are made by following both functions of step increase and step decrease of the input salt concentration ( $c_1$ ). For step increase of  $c_1$ , concentration of  $c_1$  is increased immediately by an amount of  $+0.002$  g/ml. The solid line in **Figure 6** represents the closed loop responses of Configuration-2 to a step increase change in  $c_1$ . The salt concentration in tank ( $c_3$ ) increases with increasing of the input salt concentration ( $c_1$ ); then, the controller attempts to back  $c_3$  to its set point by increasing the manipulated variable of the input water flowrate ( $f_2$ ). Again and again, as shown in **Figure 6**, P-Control results an offset of  $0.0006$  g/ml. But, PI and PID-Controls have no offset. PID-Control produces the fastest responses compared with P and PI-Controls; the concentration of  $c_3$  can be returned to its set point at time about 900 seconds.

The dashed line in **Figure 6** represents the closed loop responses of Configuration-2 to a step decrease change in the input disturbance of  $c_1$ . The concentration  $c_3$  decreases with decreasing of concentration of  $c_1$ . P-Control still results an offset of  $-0.0007$  g/ml. Both PI and PID-Controls are able to eliminate an offset. Again and again, PID-Control produces the fastest response compared with P and PI-Controls; the controlled variable of  $c_3$  can be returned to its set point at time about 700 seconds.

In general, closed loop responses of PID-Control are the same qualitative dynamic characteristics as those resulting from PI-Control. By increasing the value of proportional gain ( $K_c$ ) and/or decreasing the value of integral time constant ( $\tau_i$ ), the speed of closed loop response increases significantly. However increasing  $K_c$  and/or decreasing  $\tau_i$ , the response become more oscillatory and may lead to instability. This problem could be overcome by introducing the derivative mode that conveys a stabilizing effect to the system. Thus, the derivative control action not only gives faster response but also results more robust response [4], [14].

#### 4 Conclusion

The two composition control configurations in a 10 L mixing tank have been proposed. The open loop on off method for tuning of composition control parameters for both configurations has been successfully done in laboratory. The open loop experiment gave controller gains  $68790$  [ $\text{ml}^2/(\text{g}\cdot\text{sec})$ ] and  $-61146$  [ $\text{ml}^2/(\text{g}\cdot\text{sec})$ ] for Configuration-1 and Configuration-2, respectively. The integral time constant ( $\tau_i$ ) and the derivative time constant ( $\tau_D$ ) were the same, they were 80 seconds and 19 seconds, respectively. Based on our closed loop simulation results, the resulted PID parameters of the two configurations were able to produce stable responses to step input changes in water volumetric flowrate, salt solution volumetric flowrate, and salt concentration. This study reveals that by tuning of PID control parameters properly, the control system is able to give stable responses to the input disturbance changes. This study also reveals that PID control gives fastest responses compared with P and PI controls.

**Acknowledgements.** The financial support from Institute for Research and Community Development of Universitas Pembangunan Nasional "Veteran" Yogyakarta for this research is gratefully acknowledged. We appreciate the technical support on the use of free software SCILAB. We also thank C.F. Prihantono, S.M. Akbar, M. Arief, and A.N. Azizsol for helping us during our research in laboratory.

#### References

- [1] C.A. Smith and A.B. Corripio, *Principles and Practice of Automatic Process Control*, 2<sup>nd</sup> ed., John Wiley & Sons, Inc., USA, 1997.

- [2] C. Dalen and D. Di Ruscio, A Semi-Heuristic Process-Reaction Curve PID Controller Tuning Method, *Modeling, Identification and Control: A Norwegian Research Bulletin*, **39** (2018), no. 1, 37 – 43.  
<https://doi.org/10.4173/mic.2018.1.4>
- [3] C.V.N. Rao, A.S. Rao and R.P. Sree, Design of PID Controllers for Pure Integrator Systems with Time Delay, *International Journal of Applied Science and Engineering*, **9** (2011), no. 4, 241 – 260.  
[http://www.cyut.edu.tw/~ijase/2011N9\(4\)/2\\_021012.pdf](http://www.cyut.edu.tw/~ijase/2011N9(4)/2_021012.pdf)
- [4] G. Stephanopoulos, *Chemical Process Control: An Introduction to Theory and Practice*, PTR. Prentice-Hall, Inc., A Simon and Shuster Company, New Jersey, 1984.
- [5] M. Shamsuzzohaa, S. Skogestada, I.J. Halvorsen, On-Line PI Controller Tuning Using Closed-Loop Setpoint Response, *Proceedings of the 9<sup>th</sup> International Symposium on Dynamics and Control of Process Systems (DYCOPS 2010)*, Leuven, Belgium, 2010 Mayuresh Kothare, Moses Tade, Alain Vande Wouwer, Ilse Smets (Eds.), 497 - 502;  
<https://brage.bibsys.no/xmlui/bitstream/handle/11250/2466121/SINTEF%2BS18231.pdf?sequence=2&isAllowed=y>
- [6] R.J. Álvaro, A.M. María and F.B. David, Level Control in A System of Tanks in Interacting Mode Using Xcos Software, *Contemporary Engineering Science*, **11** (2018), no. 2, 63 - 70.  
<https://doi.org/10.12988/ces.2018.712206>
- [7] Scilab software available at [www.scilab.org](http://www.scilab.org)
- [8] S.T. Dharan, K. Kavyarasan and V. Bagyaveereswaran, Tuning of PID controller using optimization techniques for a MIMO process, *IOP Conf. Series: Materials Science and Engineering*, **263** (2017), 052019.  
<https://doi.org/10.1088/1757-899x/263/5/052019>
- [9] T.E. Marlin, *Designing Processes and Control Systems for Dynamic Performance*, 2<sup>nd</sup> ed., McGraw-Hill, USA, 1995.
- [10] W.L. Luyben, *Process Modeling, Simulation and Control for Chemical Engineers*, 2<sup>nd</sup> ed., Chemical Engineering Series, Mc-Graw-hill International Editions, New York USA, 1996.
- [11] W.L. Luyben, *Plantwide Dynamic Simulators in Chemical Processing and Control*, Marcel Dekker, Inc., USA, 2002.

- [12] Y.D. Hermawan, Design of Flow Control System with A Kickback Flow as A Manipulated Variable, *EKSERGI, Journal of Chemical Engineering of UPN "Veteran" Yogyakarta*, **14** (2017), no. 2, 23 - 28.  
<http://jurnal.upnyk.ac.id/index.php/eksergi/article/view/2089>
- [13] Y.D. Hermawan, Implementation of Process Reaction Curve for Tuning of Temperature Control Parameters in A 10 L Stirred Tank Heater, *Journal of Materials Science and Engineering A 1*, (2011), 572-577.  
<http://www.davidpublisher.org/Public/uploads/Contribute/55fa0fe6b0f06.pdf>
- [14] Y.D. Hermawan and G. Haryono, Dynamic Simulation and Composition Control in A 10 L Mixing Tank, *Jurnal Reaktor*, **14** (2012), no. 2, 95 – 100.  
<https://doi.org/10.14710/reaktor.14.2.95-100>
- [15] Y.D. Hermawan, R. Reningtyas, S.D. Kholisoh and T.M. Setyoningrum, Design of Level Control in A 10 L Pure Capacitive Tank: Stability Analysis and Dynamic Simulation, *International Journal of Science and Engineering (IJSE)*, **10** (2016), no. 1, 10 – 16.  
<http://www.ejournal.undip.ac.id/index.php/ijse/article/view/8538/pdf>

**Received: October 26, 2018; Published: November 30, 2018**

# Tuning of PID Controller Using Open Loop On Off Method and Closed Loop Dynamic Simulation in a 10 L Mixing Tank

---

## ORIGINALITY REPORT

---

2%

SIMILARITY INDEX

%

INTERNET SOURCES

%

PUBLICATIONS

2%

STUDENT PAPERS

---

## PRIMARY SOURCES

---

1

Submitted to UPN Veteran Yogyakarta

Student Paper

2%

---

Exclude quotes  On

Exclude matches  < 2%

Exclude bibliography  On