

Vol 14, No 2 (2017)

Eksergi Volume 14 No 2 2017

DOI: <https://doi.org/10.31315/e.v14i2>

Table of Contents

Pengaruh Variasi Komposisi Pada Campuran Limbah Cair Aren dan Kotoran Sapi Terhadap Produksi Biogas Ramdiana Ramdiana	12-17
Pengaruh Penambahan Vermiculite Termodifikasi Cu²⁺ sebagai Media Imobilisasi Bakteri Anaerob pada Produksi Biogas terhadap Parameter Kinetika Gregorius Prima Indra Budianto, Wisnu Arfian Anditya Sudjarwo	18-22
Design of Flow Control System with A Kickback Flow as A Manipulated Variable Yulius Deddy Hermawan	23-28
Pemanfaatan Asap Cair Food Grade yang Dimurnikan dengan Arang Aktif sebagai Pengawet Ikan Nila Siti Salamah, Siti Jamilatun	29-34
Dewatering Batubara Jorong, Kalimantan Selatan Dengan Menggunakan Minyak Goreng Bekas Dan Minyak Tanah Danang Jaya	35-39
Pengembangan Pemanfaatan Pengolahan Air Dalam Upaya Pemenuhan Kebutuhan Air di Dusun Temuireng, Desa Girisuko, Panggang, Gunungkidul Bambang Sugiarto	40-52
Pra-Rancangan Instalasi Pengolahan Air Limbah (Ipal) Industri Batik (Studi Kasus Batik Sembung, Sembungan Rt.31/Rw.14, Gulurejo, Lendah, Kulonprogo) Sri Hastutiningrum, Purnawan Purnawan	52-61
Perbaikan Mutu Bodi Keramik Lempung Pundong Dengan Penambahan Pecahan Kaca Lampu Neon Bekas Abdullah Kuntaarsa	62-71

OPEN JOURNAL SYSTEMS

USER

Username Password Remember me

JOURNAL CONTENT

Search

#plugins.block.navigation.searchS

All

Browse

- ▶ By Issue
- ▶ By Author
- ▶ By Title
- ▶ Other Journals

CURRENT ISSUE

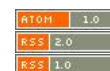

Eksergi p-ISSN 1410-394X, e-ISSN 2460-8203, is published by Chemical Engineering Department, Faculty of Industrial Technology, Universitas Pembangunan Nasional "Veteran" Yogyakarta.

Contact Prodi Teknik Kimia UPN "Veteran" Yogyakarta Jl. SWK 104 (Lingkar Utara) Condong catur Sleman Yogyakarta



Eksergi by <http://jurnal.upnyk.ac.id/index.php/eksergi/index/> is licensed under a Creative Commons Attribution-NonCommercial-ShareAlike 4.0 International License.

8,764

Lihat Statistik Jurnal Kami

Editorial Team

Editor in Chief

Dr. Muhamad Maulana Azimatun Nur, ST., MT, Indonesia

Managing Editor

Sri Wahyu Murni, Chemical Engineering UPN "Veteran" Yogyakarta
Renung Reningtyas, Chemical Engineering, Faculty of Industrial Technology, UPN "Veteran" Yogyakarta
Wibiana Wulan Nandari, Chemical Engineering UPN "Veteran" Yogyakarta, Indonesia

Editorial Board

Ir. Mahreni Mahreni, MT., PhD., Universitas Pembangunan Nasional "Veteran" Yogyakarta, Indonesia
Dr. Avido Yuliestyan, Universitas Pembangunan Nasional Veteran Yogyakarta, Indonesia
Harso Pawignyo, Teknik Kimia, UPN "Veteran" Yogyakarta, Indonesia
Dr. Yulius Deddy Hermawan, ST., MT, Chemical Engineering, Faculty of Industrial Technology, UPN "Veteran" Yogyakarta
Dr. Adi Ilcham, ST., MT, Chemical Engineering, Faculty of Industrial Technology, UPN "Veteran" Yogyakarta

Member of Editor

Prof. Dr. Ir. Arief Widjaja, M.Eng, Chemical Engineering, Faculty of Industrial Technology, ITS, Surabaya
Dr. Ir. IGS Budiawan, M.T., Chemical Engineering UPN "Veteran" Yogyakarta
Ir. Akhmad Zainal Abidin, MSc, PhD, Chemical Engineering, Faculty of Industrial Technology, ITB, Bandung
Dr. Budiyo ., Chemical Engineering, Faculty of Engineering, Diponegoro University, Semarang
Dr. Yalun Arifin, Chemical Engineering, Curtin University Sarawak, Malaysia, Malaysia
Dr. Muhamad Sahlan, Chemical Engineering, Universitas Indonesia
Dr. Ir. Ratnawati, MT ., Chemical Engineering, Faculty of Engineering, Diponegoro University, Semarang
Dr. Stefanus Muryanto, M.EngSc., Ph.D, Chemical Engineering, Universitas 17 Agustus 1945 Semarang

OPEN JOURNAL SYSTEMS

USER

Username

Password

Remember me

Login

JOURNAL CONTENT

Search

##plugins.block.navigation.searchS

All ▾

Search

Browse

▶ By Issue

▶ By Author

▶ By Title

▶ Other Journals

Eksergi p-ISSN 1410-394X, e-ISSN 2460-8203, is published by Chemical Engineering Department, Faculty of Industrial Technology, Universitas Pembangunan Nasional "Veteran" Yogyakarta.

Contact Prodi Teknik Kimia UPN "Veteran" Yogyakarta Jl. SWK 104 (Lingkar Utara) Condong catur Sleman Yogyakarta



Eksergi by <http://jurnal.upnyk.ac.id/index.php/eksergi/index/> is licensed under a Creative Commons Attribution-NonCommercial-ShareAlike 4.0 International License.

Perancangan Sistem Pengendalian Laju Alir Cairan dengan Aliran *Kickback* sebagai Variabel Termanipulasi

Design of Flow Control System with A Kickback Flow as A Manipulated Variable

Yulius Deddy Hermawan^{a*}

^aDepartment of Chemical Engineering, Faculty of Industrial Engineering, UPN "Veteran" Yogyakarta,
Jl. SWK 104 (Lingkar Utara) Condongcatur, Yogyakarta, 55283, Indonesia

Artikel histori :

Diterima Oktober 2017
Diterima dalam revisi Oktober 2017
Diterima November 2017
Online Desember 2017

ABSTRAK: Percobaan loop terbuka dinamika aliran air di dalam pipa telah dilaksanakan di laboratorium. Pompa digunakan untuk mengalirkan air di dalam pipa. Sebagian cairan keluar pompa dikembalikan ke hisapan pompa (*kickback*) dan diatur untuk menjaga laju alir cairan yang menuju ke proses lanjut. Percobaan laboratorium loop terbuka telah menghasilkan parameter tunak, yaitu laju alir *discard* pompa $\bar{f}_o=16,6$ [L/min], laju alir *kickback* $\bar{f}_k=5,8$ [L/min], dan laju alir ke proses lanjut $\bar{f}=10,8$ [L/min]. Selanjutnya, parameter tunak hasil dari percobaan laboratorium digunakan sebagai kondisi awal pada simulasi loop tertutup dengan pemrograman komputer. Studi ini telah mengusulkan konfigurasi pengendalian laju aliran dengan memanipulasi laju alir *kickback*. *Proportional Integral* (PI) diusulkan untuk mengendalikan laju aliran dan kriteria kestabilan Routh-Hurwitz (RH) dipilih untuk memperkirakan kisaran parameter *gain* pengendali (K_c) yang memberikan respons stabil. Model loop tertutup diselesaikan secara analitik dengan metode *Laplace* untuk masalah *servo* dan *regulatory*. Perubahan *set point* dan gangguan aliran dibuat berdasarkan fungsi tahap. *Software* scilab digunakan untuk melakukan simulasi loop tertutup. Berdasarkan kriteria kestabilan RH, *gain* pengendali harus negatif agar memberikan respons yang stabil. Simulasi loop tertutup menunjukkan bahwa dengan menggunakan parameter *gain* pengendali $K_c=-0,5$ dan konstanta waktu integral $\tau_i=0,3$ [min], respons cepat dan stabil dengan Integral Absolute Error (IAE) mendekati nol (0,0022) dapat tercapai.

Kata Kunci: pengendalian *flow*; *kickback*; PI; Routh-Hurwitz; stabil.

ABSTRACT: The open loop experiment of water flow dynamic in pipe has been done in laboratory. Pump was used to flow water in pipe. Part of liquid from discard of pump was recycled back to the suction of pump (*kickback*) and adjusted to control the liquid flow to the next process. The open loop laboratory experiment produced the steady state parameters; they were discard flowrate $\bar{f}_o=16.6$ [L/min], *kickback* flowrate $\bar{f}_k=5.8$ [L/min], and liquid flowrate to the next process $\bar{f}=10.8$ [L/min]. These steady state parameters were then used as the initial value for closed loop simulation with computer programming. This study has proposed the liquid flow control configuration by manipulating the *kickback* flow. *Proportional Integral* (PI) was proposed to control the flow and Routh-Hurwitz (RH) stability criterion was chosen to predict the range of the controller gain (K_c) that gives stable response. The closed loop model was solved analytically with Laplace method for both *servo* and *regulatory* problems. The set point change of flow and disturbance were made based on step function. The scilab software was used to do closed loop simulation. Based on RH stability criterion, the controller gain should be negative in order to give stable response. The closed loop simulation showed that by using controller gain $K_c=-0.5$ and integral time constant $\tau_i=0.3$ [min], stable and fast response with Integral Absolute Error (IAE) near to zero (0,0022) could be achieved.

Keywords: flow control; *kickback*; PI; Routh-Hurwitz; stable.

1. Introduction

System of liquid pumping in pipe is widely used in chemical process industries. Liquid flowrate is one of important parameters that must be controlled at its desired value, for examples, feed flowrate to reactor, mixing tank,

and other process equipments. In addition, the pumping flowrate must be controlled in order to prevent the propagation of mass and thermal disturbances to the next process. Therefore, the research in field of fluid flow dynamic and control is very important to be done.

Some researches in field of process dynamic and control, tuning controllers, and stability analysis have been done in both of laboratory experiments and dynamic simulation with computer. Composition dynamic in a mixing tank has been studied by Hermawan, Y.D. et al (2012), where that is clearly the composition in the tank depends on its feed flowrate. Then, Hermawan, Y.D. and Haryono, G. (2012) continued their research through closed loop simulation of composition control in a mixing tank; at that time, composition controller's parameters were tuned based on the process reaction curves resulted from the open loop experiment in laboratory. In 2016, Hermawan, Y.D. et al have proposed the liquid level control configuration in a pure capacitive tank, where the liquid level was maintained by manipulating its pump voltage, and Routh-Hurwitz (RH) stability criterion was used to predict the range of controller gain that give stable response. Recently, in 2017, Hermawan, Y.D. et al have proposed the liquid flow control configuration with pump voltage as a manipulated variable. In this work, the liquid flow control configuration with a kickback flow as a manipulated variable would be proposed and studied.

Goals of this research are to study the open loop fluid flow dynamic in pipe by using a pump with a kickback flow experimentally in laboratory, to propose the liquid flow control configuration with a kickback flow as a manipulated variable, and to do closed loop dynamic simulation by using computer. The steady state parameters would be determined from the open loop experiment in laboratory. Proportional Integral (PI) feedback control would be proposed to control the liquid flowrate. The closed loop model would be solved analytically with Laplace Transform. RH stability criterion would be used to predict the range of controller gain that gives stable response. The closed loop response of liquid flowrate to a step change in its set point and disturbance load of pump discard will also be explored in scilab software environment.

2. Material and Method

Figure 1 shows the open loop experimental apparatus setup. As can be seen in Figure 1, liquid from the tank No. 1 was pumped by a pump No. 2 and part of liquid from the discard of pump was recycled back to the suction of pump.

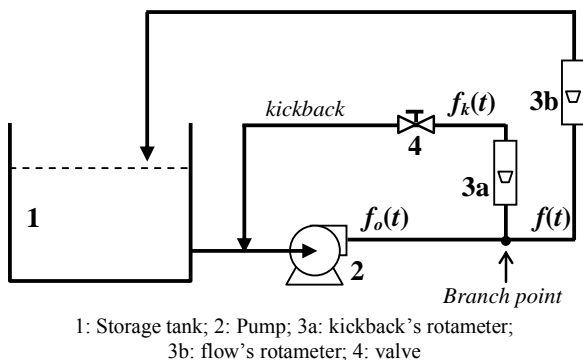

Figure 1. Open loop experimental apparatus setup.

The recycled stream to the suction of pump is known as a kickback stream. The kickback flowrate, $f_k(t)$ [L/min], can be adjusted with valve No. 4 and its volumetric rate can be determined by rotameter No 3a. While liquid flow to the next process was recycled back to the tank No. 1, and its volumetric rate, $f(t)$ [L/min], can be determined by rotameter No. 3b.

2.1. Research Procedure

This research was done through some procedures as follows:

2.1.1. Open loop experiment in laboratory

The open loop experiment in laboratory was done to determine the steady-state parameters as follows: the discard volumetric rates of pump \bar{f}_o , volumetric rate of kickback stream \bar{f}_k , and volumetric rate of stream to the next process \bar{f} . First of all, the valve No. 4 in Figure 1 was fully closed (0%-open) and the pump was then switched on; this means that the steady state discard pump flowrate is equal to the steady state flowrate to next process ($\bar{f}_o = \bar{f}$). At 0%-open of valve No. 4 in Figure 1, the discard water was stored in 1000 ml measured-glass during 3 seconds; the discard water flowrate could therefore be calculated as follows:

$$f_o = \frac{\text{measured water volume (ml)}}{3 \text{ seconds}} = \bar{f}_o \frac{\text{ml}}{\text{second}} \quad (1)$$

This first experiment was repeated 15 times, and the discard flowrate was the average value of 15 measuring experiments.

The second open loop experiment was to open the valve No. 4 in Figure 1 with 50%-open condition; the steady state water flowrate to next process (\bar{f}) was then measured with the same method as first experiment. The steady state kickback flowrate \bar{f}_k can therefore be calculated as follows:

$$\bar{f}_k = \bar{f}_o - \bar{f} \quad (2)$$

2.1.2. Stability analysis by using RH criterion

RH stability criterion was used to predict the range of controller gain in order to achieve the stable responses. PI control would be implemented to maintained liquid flowrate of f constant at its set point of f^{SP} . The proposed flow control configuration is shown in Figure 2.

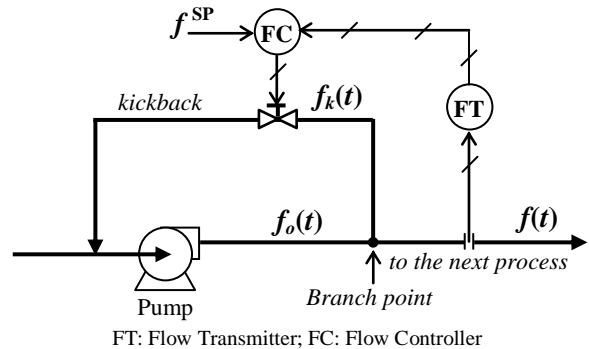

Figure 2. Proposed flow control configuration.

2.1.3. Closed loop simulation by means of computer

The closed loop simulation by means of computer was done to explore the dynamic responses to changes in its set point and the discard volumetric rate of pump. The steady state parameters resulted from the open loop experiment were then used as the initial value for closed loop simulation. The set point and pump discard changes were made based on step function with amount of 1 unit. The closed loop model was solved analytically with Laplace Transform, and the scilab software was chosen to execute rigorous dynamic simulation.

2.2. Open Loop Model

Mass balance in the branch point is written as follow:

$$f_o(t) = f_k(t) + f(t) \quad (3)$$

Rearrange equation (3), we get:

$$f(t) = f_o(t) - f_k(t) \quad (4)$$

Mass balance at initial condition:

$$\bar{f} = \bar{f}_o - \bar{f}_k \quad (5)$$

Subtraction of equation (4) and (5) results open loop model in deviation term as follows:

$$F(t) = F_o(t) - F_k(t) \quad (6)$$

where:

$$F(t) = f_o(t) - \bar{f}_o \quad (7)$$

$$F_o(t) = f_o(t) - \bar{f}_o \quad (8)$$

$$F_k(t) = f_k(t) - \bar{f}_k \quad (9)$$

Equations (7), (8), and (9) are in deviation term. Laplace transform of equation (6) in deviation term is:

$$F(s) = F_o(s) - F_k(s) \quad (10)$$

The open loop block diagram of system of fluid flow with a kickback flow is shown in Figure 3.

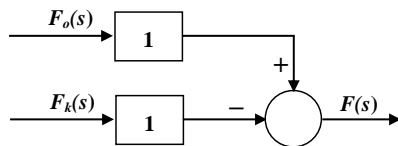

Figure 3. The open loop block diagram of system of fluid flow with a kickback flow

2.3. Closed loop model

The transfer function of PI feedback control is:

$$G_c(s) = \frac{F_k(s)}{E(s)} = \frac{K_c(\tau_I s + 1)}{\tau_I s} \quad (11)$$

(Smith, C.A., & Corripio, A.B., 1997)

For simplify, we assume that the transfer function of both measurement element and final control element are equal to 1. The closed loop block diagram for controlling the liquid flowrate with a kickback flowrate as a manipulated variable is therefore shown in Figure 4.

Based on the closed loop block diagram in Figure 4, system of closed loop equations can be written as follows:

$$F_k(s) = E(s)G_c(s) \quad (12)$$

Substitution of equation (12) to (10) results:

$$F(s) = F_o(s) - E(s)G_c(s) \quad (13)$$

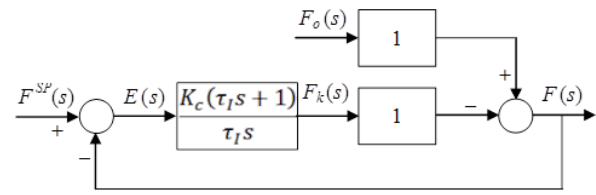

Figure 4. The closed loop block diagram of flow control.

Error $E(s)$ is defined as follows:

$$E(s) = F^{SP}(s) - F(s) \quad (14)$$

Substitution of equation (14) to (13) gives:

$$F(s) = F_o(s) - F^{SP}(s)G_c(s) + F(s)G_c(s) \quad (15)$$

Rearrange of equation (15):

$$F(s) = \frac{1}{(1-G_c(s))} F_o(s) - \frac{G_c(s)}{(1-G_c(s))} F^{SP}(s) \quad (16)$$

Equation (16) is an equation of closed loop response for system of flow control with a kickback flow as a manipulated variable.

Substitution of equation (11) to (16) gives:

$$F(s) = \frac{\tau_I s}{(1-K_c)\tau_I s - K_c} F_o(s) - \frac{K_c(\tau_I s + 1)}{(1-K_c)\tau_I s - K_c} F^{SP}(s) \quad (17)$$

Numerator and denominator of equation (17) are multiplied by $(-1/K_c)$ in order to get standard equation of first order lead-lag model:

$$F(s) = \frac{\left(\frac{\tau_I}{-K_c}\right)s}{\left(\frac{1-K_c}{-K_c}\right)\tau_I s + 1} F_o(s) + \frac{(\tau_I s + 1)}{\left(\frac{1-K_c}{-K_c}\right)\tau_I s + 1} F^{SP}(s) \quad (18)$$

Equation of servo problem (change in set point and no disturbance) can be written as follows:

$$F_o(s) = 0 \quad (19)$$

$$F(s) = \frac{(\tau_I s + 1)}{\left(\frac{1-K_c}{-K_c}\right)\tau_I s + 1} F^{SP}(s) \quad (20)$$

Equation of regulatory problem (change in disturbance and no set point change) can be written as follows:

$$F^{SP}(s) = 0 \quad (21)$$

$$F(s) = \frac{\left(\frac{\tau_I}{-K_c}\right)s}{\left(\frac{1-K_c}{-K_c}\right)\tau_I s + 1} F_o(s) \quad (22)$$

2.4. RH stability criterion

Routh-Hurwitz stability criterion was chosen to analyze the stability of the closed loop responses (Stephanopoulos, G., 1984). The stability of the closed loop response is really affected by its controller gain K_c and its integral time constant τ_I . From equations (18), (20), and (22), the characteristic equation can be written as follows:

$$\left(\frac{1-K_c}{-K_c}\right)\tau_I s + 1 = 0 \quad (23)$$

The Routh array for stability analysis of closed loop response is given as follows:

$$\text{row 1} \begin{bmatrix} \left(\frac{1-K_c}{-K_c}\right)\tau_I & 0 \\ 2 & 0 \end{bmatrix} \quad (24)$$

The flow control system will give stable response if all members in the 1st column of Routh array are positive. The members in the 1st column of Routh-Array are: $\left(\frac{1-K_c}{-K_c}\right)\tau_I$ and 1. As shown in Routh-array equation (24), the value of

1st member of 1st column, i.e. $\left(\frac{1-K_c}{-K_c}\right)\tau_I$, depends on the controller gain and integral time constant. Integral time constant is sure positive. In order to allow $\left(\frac{1-K_c}{-K_c}\right)\tau_I$ be positive, the controller gain must be negative, i.e. $K_c < 0$, as a result that the flow control system will give a stable response. This negative value of K_c is valid for feedback controller with direct acting (Smith, C.A., & Corripio, A.B., 1997).

2.5. Closed loop responses

Laplace invert of equations (20) gives closed loop responses to a step input changes in set point. Closed loop response to a step change in set point for servo problem is typically lead-lag response as follows:

$$f(t) = \bar{f} + \Delta f^{SP} \left\{ 1 + \left[\frac{-K_c}{(1-K_c)} - 1 \right] e^{-t / \left(\frac{(1-K_c)\tau_I}{-K_c} \right)} \right\} \quad (25)$$

Laplace invert of equations (22) gives closed loop responses to a step input changes in disturbance. Closed loop response to a disturbance change in pump discard flowrate for regulatory problem is typically first-order response as follows:

$$f(t) = \bar{f} + \Delta f_o \left(\frac{1}{1-K_c} \right) \left\{ e^{(K_c t) / [(1-K_c)\tau_I]} \right\} \quad (26)$$

Dynamic performance of the flow control system will be formulated from the complete closed loop response, from time $t = 0$ until steady state has been reached. Integral of the absolute value of the error (IAE) for flow controller would be used for the formulation of the flow dynamic performance. The IAE can be calculated as bellows:

$$IAE = \int_0^\infty e(t) dt \quad (27)$$

(Marlin, T.E., 1995)

where $e(t)$ is the deviation (error) of the flow response from its desired set point (f^{SP}), and written as follows:

$$e(t) = f^{SP} - f(t) \quad (28)$$

The desired flow set point (f^{SP}) is the flow at the initial condition:

$$f^{SP} = f(0) = \bar{f} \quad (29)$$

2.6. Tuning of flow control controller

The closed loop dynamic simulation in this work would directly use PI parameters that be recommended by Luyben, W.L (2002). Since the dynamics of flow measurement are fast, and the time constant for moving control valves are small, therefore the controller can be tuned with a small integral time constant (τ_I) and modest controller gain (K_c). This work used a value of $K_c = -0.5$ and a value of $\tau_I = 0.3$ minutes. Those PI parameters are often used for flow controllers (Luyben, W.L., 2002).

3. Result and Discussion

3.1. The open loop experiment results

The open loop experiment in laboratory gave the steady state parameters as shown in Table 1. The steady state parameters would then be used as the initial value on the closed loop dynamic simulation.

Table 1. Steady state parameters.

No	Variable	value
1	Kickback flowrate \bar{f}_k , [L/min]	5.8
2	Flowrate to the next process \bar{f} , [L/min]	10.8
3	Discard flowrate of pump \bar{f}_o , [L/min]	16.6

3.2 Dynamic simulation of flow control system

Closed loop dynamic simulations are done for both servo and regulatory problems. The set point and disturbance changes were made based on the step function. Controller gain, integral time constant, and IAE results for both servo and regulatory problems are listed in Table 2.

Table 2. PI parameters and IAE results.

Controller gain K_c	Integral time constant τ_I [min]	Integral Absolute Error (IAE)	
		Step increase	Step decrease
-0.5	0.3	0.0022	0.0022

3.2.1 Servo problem

Closed loop responses to a change in set point f^{SP} are illustrated in Figure 5. Changes in set point were made by following both functions of step increase and step decrease at time equal to 5 minutes (Figure 5.a).

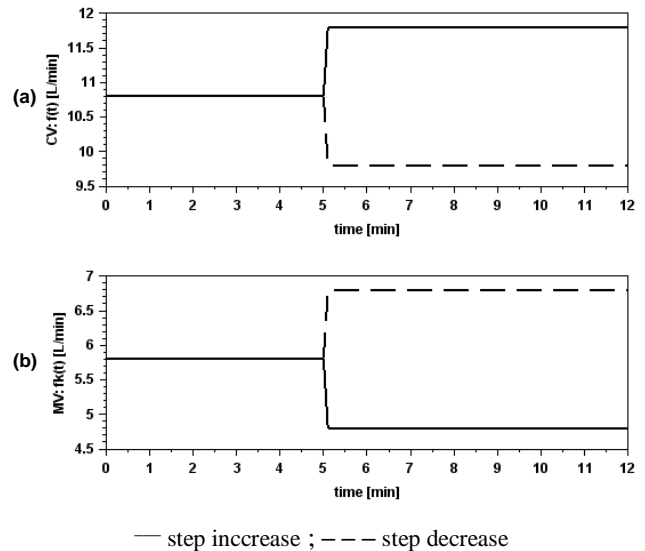

Figure 5. The closed loop responses to a change in set point of flow ($K_c = -0.5$; $\tau_I = 0.3$ minutes).

For step increase change in set point, the controlled variable (CV) of f is increased by an amount of 1 L/minute (Figure 5.a). The solid line in Figure 5 represents the closed loop responses to a step increase change in set point. The flowrate increases spontaneously from 10.8 to 11.8 L/min at time equals to 5 minutes (Figure 5.a). In order to satisfy the

material balance, the manipulated variable (MV) of f_k decreases immediately from 5.8 to 4.8 L/min (Figure 5.b). As can be seen in Figure 5, closed loop responses of the PI controller with controller gain $K_c = -0.5$ and integral time constant $\tau_I = 0.3$ minutes gives a fast and stable response to a step increase change in set point.

For step decrease change in set point, the controlled variable (CV) of f is decreased by an amount of 1 L/minute (Figure 5.a). The dashed line in Figure 5 represents the closed loop responses to a step decrease change in set point. The flowrate decreases spontaneously from 10.8 to 9.8 L/min at time equals to 5 minutes (Figure 5.a). The manipulated variable (MV) of f_k increases immediately from 5.8 to 6.8 L/min (Figure 5.b). Again as shown in Figure 5, the closed loop responses of the PI controller with controller gain $K_c = -0.5$ and integral time constant $\tau_I = 0.3$ minutes gives a fast and stable response to a step decrease change in set point.

3.2.2 Regulatory problem

Figure 6 shows the closed loop responses to a disturbance changes in discard flowrate of pump f_o . This disturbance may be happened in specialty case of electricity, such as change in pump voltage causes change in discard flowrate. Disturbance changes in discard flowrate of pump were made by following both functions of step increase and step decrease at time equal to 5 minutes (Figure 6.a).

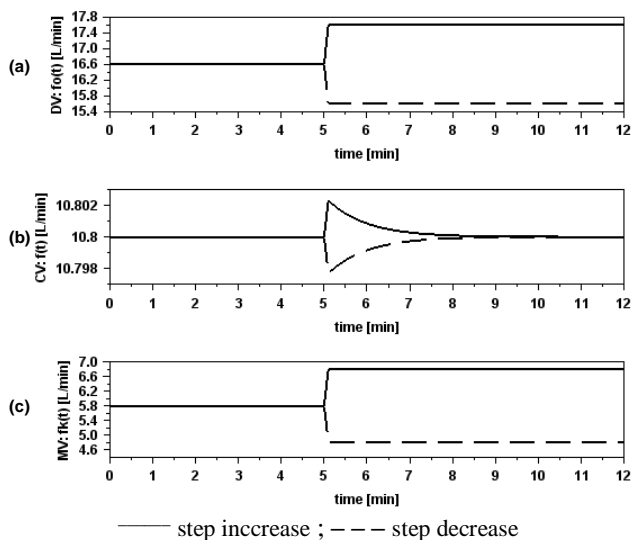

Figure 6. The closed loop responses to a change in disturbance of discard flowrate of pump ($K_c = -0.5$; $\tau_I = 0.3$ minutes).

For step increase change in discard flowrate of pump, the disturbance variable (DV) of f_o is increased by an amount of 1 L/minute (Figure 6.a). The closed loop responses to a step increase change in discard flowrate of pump are represented by the solid line in Figure 6. As can be seen in Figure 6, first the controlled variable (CV) increases immediately and its value can then be back to its set point at

time about 9 minutes (Figure 6.b). This is understandable that the manipulated variable (MV) of kickback flowrate increases immediately from 5.8 to 6.8 L/min (Figure 6.c).

For step decrease change in discard flowrate of pump, the disturbance variable (DV) of f_o is decreased by an amount of 1 L/minute (Figure 6.a). The dashed line in Figure 6 represents the closed loop responses to a step decrease change in discard flowrate of pump. As can be seen in Figure 6, first the controlled variable (CV) decreases immediately and its value can then be returned to its set point at time about 9 minutes (Figure 6.b) because the manipulated variable (MV) of kickback flowrate decreases immediately from 5.8 to 4.8 L/min (Figure 6.c).

4. Conclusion

This research has studied fluid dynamic with a kickback flow. A flow control configuration with a kickback flow as a manipulated variable has been proposed. The closed loop dynamic responses have been explored through dynamic simulation in scilab software environment. The proposed flow control system with controller gain $K_c = -0.5$ and integral time constant $\tau_I = 0.3$ minute gave fast and stable responses for both servo and regulatory problems.

Acknowledgments

I appreciate the technical support on the use of free software SCILAB. I gratefully acknowledge Satrio Nugroho and Vika Rahmalia of Chemical Engineering student of UPN "Veteran" Yogyakarta for helping me during my research in laboratory.

References

- Hermawan, Y.D., Haryono, G., Agustin, M., & Abiad, H., 2012, Dinamika Komposisi pada Sistem Tangki Pencampur 10 L, *Prosiding Seminar Nasional Teknik Kimia "Kejuangan"*, Jurusan Teknik Kimia UPNVY, 6 Maret 2012, ISSN: 1693-4393, hlm. C15-1-C15-6. <http://jurnal.upnyk.ac.id/index.php/kejuangan/article/view/519>
- Hermawan, Y.D. & Haryono, G., 2012, Dynamic Simulation and Composition Control in A 10 L Mixing Tank, *Jurnal Reaktor*, Jurnal Terakreditasi SK No. 66b/DIKTI/Kep/2011, Jurusan Teknik Kimia UNDIP, ISSN 0852-0798, Vol.14 No 2, Oktober: 95-100. DOI: 10.14710/reaktor.14.2.95-100. <http://ejournal.undip.ac.id/index.php/reaktor/article/view/4802/4352>
- Hermawan, Y.D., Reningtyas, R., Kholisoh, S.D. & Setyoningrum, T.M., 2016, Design of Level Control in A 10 L Pure Capacitive Tank: Stability Analysis and Dynamic Simulation, *International Journal of Science and Engineering (IJSE)*, Vol.10 No. 1, Januari: 10-16, DOI: 10.12777/ijse.10.1.10-16. <http://www.ejournal.undip.ac.id/index.php/ijse/article/view/8538/pdf>

- Hermawan, Y.D., Krisnawan, D.A. & Kinanti, N.L.D.W., 2017, Perancangan Sistem Pengendalian Laju Alir Cairan dengan Voltase Pompa sebagai Variabel Termanipulasi, *Seminar Nasional Teknik Kimia (SNTK) UNNES*, hlm. 92-99.
<http://seminar.unnes.ac.id/event-semnastekkim/page/publikasi>,
<https://drive.google.com/file/d/0B8DhN-qAN4qsd3RKMUNvdmtfR2M/view>
- Luyben, W.L., 2002, *Plantwide Dynamic Simulators in Chemical Processing and Control*, Marcel Dekker, Inc., USA.
- Marlin, T.E., 1995, *Designing Processes and Control Systems for Dynamic Performance*, 2nd ed., McGraw-Hill, USA.
- Smith, C.A., & Corripio, A.B., 1997, *Principles and Practice of Automatic Process Control*, 2nd ed., John Wiley & Sons, Inc., USA.
- Stephanopoulos, G., 1984, *Chemical Process Control: An Introduction to Theory and Practice*, PTR. Prentice-Hall, Inc., A Simon and Shuster Company, New Jersey.