

# *Integrated simulation system of CO<sub>2</sub> gas injection application for enhanced oil recovery in the oil field*

**Dedy Kristanto, Yulius Deddy  
Hermawan, Hariyadi & Yusmardhany  
Yusuf**

**Journal of Petroleum Exploration and  
Production Technology**

ISSN 2190-0558  
Volume 10  
Number 8

J Petrol Explor Prod Technol (2020)  
10:3917-3923  
DOI 10.1007/s13202-020-00955-9

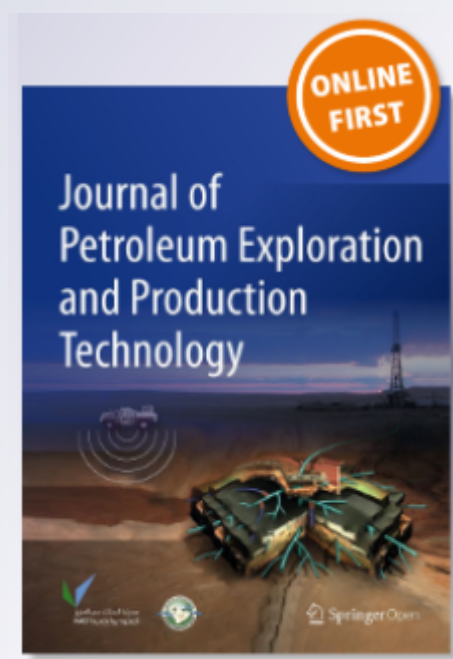

**Your article is published under the Creative Commons Attribution license which allows users to read, copy, distribute and make derivative works, as long as the author of the original work is cited. You may self-archive this article on your own website, an institutional repository or funder's repository and make it publicly available immediately.**



# Integrated simulation system of CO<sub>2</sub> gas injection application for enhanced oil recovery in the oil field

Dedy Kristanto<sup>1</sup> · Yulius Deddy Hermawan<sup>2</sup> · Hariyadi<sup>1</sup> · Yusmardhany Yusuf<sup>2</sup>

Received: 13 May 2020 / Accepted: 6 July 2020 / Published online: 16 July 2020  
© The Author(s) 2020

## Abstract

CO<sub>2</sub> gas injection is one of the recommended enhanced oil recovery (EOR) methods by injecting CO<sub>2</sub> through reservoir pores after the residual saturation is reached, since CO<sub>2</sub> dissolves easily in oil phase as confirmed by many other researchers in pertaining field studies. An integrated system is urgently required for assessing CO<sub>2</sub>-EOR study, covering multi-disciplinary aspects as follows: geology, geophysics, reservoir, production, process and economic. Hence, those systems must be reliable in suggesting final decision for feasibility of CO<sub>2</sub>-EOR operation program, applicable either for pilot scale or for full scale. This paper is proposing an integrated system evaluation, which has the following features: (1) estimate fraction of dissolved CO<sub>2</sub>, (2) estimate viscosity reduction, (3) estimate future oil productivity index resulted, (4) forecast incremental oil production, (5) estimate surface facilities equipment design, (6) evaluate economical aspects and (7) generate final decision for feasibility of CO<sub>2</sub>-EOR operation program. Finally, as the main objective of this program, those systems will present a picture of essential reason why we need to promote or reject CO<sub>2</sub>-EOR plan program, and also some recommendations will be presented in case the CO<sub>2</sub>-EOR plan does not perform as expected.

**Keywords** CO<sub>2</sub> gas injection · Enhanced oil recovery (EOR) · Integrated system

## Introduction

Indonesia approximately has 998 million BOE (Barrel Oil Equivalent) of national energy demand, relying on crude oil as the main energy source (MEMRRI 2017). Furthermore, 90% of national oil production comes from depleted oil fields. If we persist in this situation without doing any exploration and discoveries, 3.6 billion of proven Indonesia's oil reserve will completely drained within the next 11 years (SKK Migas 2016).

Pertamina as an Indonesia's national oil and gas company has about 110 Tscf of natural gas sources, associated with large amount of CO<sub>2</sub> content (Suarsana 2010). CO<sub>2</sub> could reduce heating value and contribute to global warming this situation can lead to detrimental issues in economic and environmental aspect, but from another perspective we can turn these issues into new opportunity to enhance oil production by employing CO<sub>2</sub>-EOR. To raise that program, it is necessary to initiate a conceptual feasibility study of CO<sub>2</sub>-EOR, engaging essential aspect, such as thermodynamic equilibrium of CO<sub>2</sub> dissolved in oil phase, oil recovery gain due to dissolved CO<sub>2</sub>, CO<sub>2</sub> transport and CO<sub>2</sub> natural gas purification facilities.

Some previous research has been greatly conducted by some researchers including feasibility study (LPPM UPN 2011; Muslim 2013; Chae and Lee 2015; Lee 2015; Abdurrahman et al. 2017), technical research (Suarsana 2010; Rostami et al. 2017) and laboratory experiments (Abdassah et al. 2000). From those studies, we can derive some essential factors of CO<sub>2</sub>-EOR fruitfulness, such as decreased oil viscosity (Abdassah et al. 2010; Rostami et al. 2017; Miller and Jones 1981), oil expansion (Emera and Sarma 2006), oil extraction and evaporation (Abdassah 2010; Leach and

✉ Dedy Kristanto  
dedykris.upn@gmail.com

✉ Yulius Deddy Hermawan  
ydhermawan@upnyk.ac.id

<sup>1</sup> Department of Petroleum Engineering, Faculty of Mineral Technology, Universitas Pembangunan Nasional "Veteran" Yogyakarta, Jl. Padjajaran 104 (Lingkar Utara) Condongcatur, Yogyakarta 55283, Indonesia

<sup>2</sup> Department of Chemical Engineering, Faculty of Industrial Engineering, Universitas Pembangunan Nasional "Veteran" Yogyakarta, Jl. Padjajaran 104 (Lingkar Utara) Condongcatur, Yogyakarta 55283, Indonesia

Yellig 1981; Yellig 1982) and solution gas drive (Holm and Josendal 1974; Sohrabi and Emadi 2012).

This paper is tackling an integrated system of some essential aspects in CO<sub>2</sub>-EOR process, encompassing many aspects as follows: geophysics, geological, reservoir and production (GGRP) data properties, the maximum CO<sub>2</sub> dissolved at certain pressure and injection rates to increase oil recovery, purification facilities and economics, which can be relied upon as an application to provide simple, precise and fast screening for CO<sub>2</sub>-EOR.

## Research methodology

The methodology derived from essential aspects in CO<sub>2</sub>-EOR as mentioned earlier, begins with GGRP data properties followed by rate and injection pressure of CO<sub>2</sub> design. These data will govern oil viscosity potential which affects oil recovery gain and surface facilities design. Consequently, these two outputs will govern economic evaluation used for final decision. All of these methods are presented in Fig. 1.

### Geology, geophysics, reservoir, and production data (GGRP data)

As initial requisite data, geology, geophysics, reservoir and production detail data are as follows:

- Geology and geophysics data
  - Map area, topography and geology
  - Geophysical survey, contour map and isopach map (formation thickness, porosity, permeability)

### b. Reservoir data

- Rock properties (porosity, permeability, saturation, etc.)
- Fluid properties (specific gravity, viscosity, oil formation volume factor, etc.)

### c. Production data

Flowing well pressure (Pwf), production rate, inflow performance relationship (IPR), tubing performance relationship (TPR), bottom-hole temperature (BHT)

### Oil recovery due to oil viscosity potential

To compute oil recovery gain, we use five governing equations which are solved sequentially, and detail explanations are presented below:

- CO<sub>2</sub> mass equilibrium is modeled under steady-state condition, determined by CO<sub>2</sub> injection rate.

$$y_{\text{CO}_2} \Big|_t = y_{\text{CO}_2} \Big|_{t=0} - \frac{B_o \rho_o s_o \epsilon}{Q_{\text{inj}} t} \left( x_{\text{CO}_2} \Big|_t - x \Big|_{t=0} \right) \quad (1)$$

- CO<sub>2</sub> mass equilibrium considered by thermodynamic aspects, where the fugacity of each phase is a function of Peng–Robinson's (EOS) equation of state (EOS). By engaging EOS, this simulation can compute CO<sub>2</sub> injection scenario whether in liquid or in gas phase. In cases of injected CO<sub>2</sub> in undersaturated liquid phase, fugacity is  $\approx 1$ .

$$x_{\text{CO}_2}^{\text{oil}} \phi_{\text{CO}_2}^{\text{oil}}(P, T) = y_{\text{CO}_2}^{\text{gas}} \phi_{\text{CO}_2}^{\text{gas}}(P, T) \quad (2)$$

**Fig. 1** Flowchart of CO<sub>2</sub>-EOR study

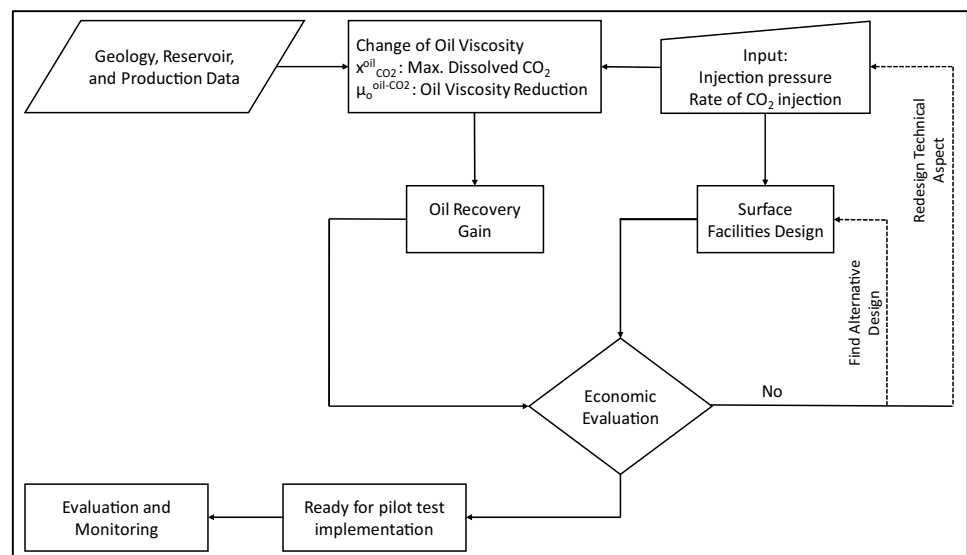

3. As the amount of dissolved CO<sub>2</sub> has increased, chemical structure of oil will be changed, this process could lower oil viscosity, and the change of viscosity is described by the proposed correlation of Barclay and Mishra (2016):

$$\mu_{\text{oil}-\text{CO}_2} = \mu_{\text{oil}}(1 + 0.01113T - 1.78210)x_{\text{CO}_2}^{\text{oil}} \quad (3)$$

4. Since oil viscosity has reduced, mobility ratio also reduced, meaning oil production will increase as oil will move easier in the pore space. The oil production and oil viscosity relation is described by Vogel inflow performance relationship (IPR) equation:

$$Q_o = J(\bar{p}_r - p_{\text{wf}}) + \frac{Jp_b}{1.8} \left( 1 - 0.2 \left( \frac{p_{\text{wf}}}{p_b} \right) + 0.8 \left( \frac{p_{\text{wf}}}{p_b} \right)^2 \right) \quad (4)$$

where

$$J = 0.00708 \text{ kh} \left( \mu_o B_o \left( \ln \left( \frac{r_e}{r_w} \right) - 0.5 \right) \right)^{-1} \quad (5)$$

5. Percent of the amount of oil produced is described by the equation below:

$$\text{RF} = \frac{s_{\text{oi}} - s_o}{s_o} \quad (6)$$

where oil recovery gain is derived from the mass balance equation in an unsteady state, with oil saturation ( $s_o$ ) is dependent variable, and time ( $t$ ) is independent variable.

$$s_o = s_{\text{oi}} - \frac{Qt}{\epsilon V_R B_o} \quad (7)$$

There is two alternatives design of CO<sub>2</sub> purification facilities, as follows: distillation and absorption method. Distillation column is computed by three main equations: mass balance, phase balance and heat balance. These three equations are solved using a numerical program or a process simulation program, whereas in the absorption method, CO<sub>2</sub> separation mechanism begins with: natural gas entering through the bottom of the absorption column, while absorbent liquid enters through the top of the tower, and the gas and liquid will contact each other, where the absorbent liquid will absorb the CO<sub>2</sub>, and liquid absorbent is mainly comprised of alkylamines, such as diethanolamine (DEA), monoethanolamine (MEA) and methyl-diethanolamine (MDEA) (Miller et al. 1978; Gary et al.

1984; Kohl and Richard 1997; LPPM 2011). Estimation of absorber tower is calculated based on two concepts, that is concept of phase equilibrium between gas and liquid, analogously as Eq. (2) and also the concept of mass transfer between gas and liquid.

## Results and discussion

The integration of CO<sub>2</sub> gas injection simulation was started from building flowchart as shown in Fig. 1, begun with GGRP data and operating pressure, these data will generate estimation of oil recovery gain and surface facilities design, this information could be our guidance to evaluate whether this project is feasible or not, data from GGRP give essential information such as reservoir size and fluid properties, these data are delivered into three following equations, as follows: equation of mass balance under steady-state condition, CO<sub>2</sub> phase equilibrium by Peng–Robinson equation of state and change of oil viscosity.

We are attempting to simulate a CO<sub>2</sub> flood by injecting CO<sub>2</sub> mixture in gas phase into reservoir with total targeted drainage volume as much as 0.5 MMCF, total injected gas is 31 MMSCFD flowing through many injection well, and injection pressure was varying from 600 up to 2400 psig. The reservoir and injection data are presented in Tables 1 and 2.

The simulation starts from computing the effects of CO<sub>2</sub> concentration in oil phase as a function of the rate of CO<sub>2</sub> injection. As a result, as presented in Fig. 2, we can see the intersection point between the CO<sub>2</sub>-oil absorption line due to the CO<sub>2</sub> injection process (Eq. 1) and the inter-phase equilibrium line computed from EOS (Eq. 2). The point of intersection is the optimum CO<sub>2</sub>-oil equilibrium point.

As a result, 0.027 CO<sub>2</sub> fraction in crude oil phase was obtained at 600 psig of CO<sub>2</sub> injection pressure and 1800 days cumulative, dissolved CO<sub>2</sub> will reduce oil viscosity with respect to cumulative days injection, followed by the alteration of well IPR, and then, the oil recovery gain will be estimated as shown in Fig. 3 through Fig. 5 and Table 4, respectively.

**Table 2** Injection fluid properties data

$Q_{\text{inj}}$ (MMSCFD)	Pressure (psig)	Temperature (°F)	% mole CO <sub>2</sub>
100	600	180	0.85

**Table 1** Reservoir properties data

Vol. reservoir drainage target (cuft)	Pwf (psig)	$\phi$	$s_o$	°API	$\mu_o$ (Cp)	$B_o$ (RB/STB)	BHT (°F)	Oil prod. (BOPD)
500.000	200	0.11	0.20	33.80	2.45	1.2	180	300

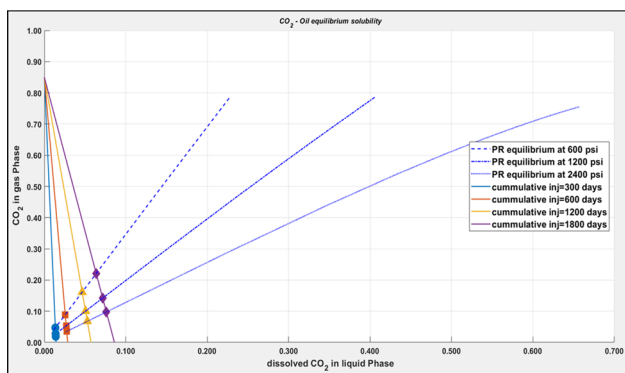

**Fig. 2** Graph of the CO<sub>2</sub> equilibrium in the gas-oil phase. Note: filled circle=cumulative injection day 300, filled square=cumulative injection day 600, filled triangle=cumulative injection day 1200, filled diamond=cumulative injection day 1800, straight line=phase equilibrium at P=600 psig, straight with dotted line=phase equilibrium at P=1200 psig, dotted line=phase equilibrium at P=2400 psig

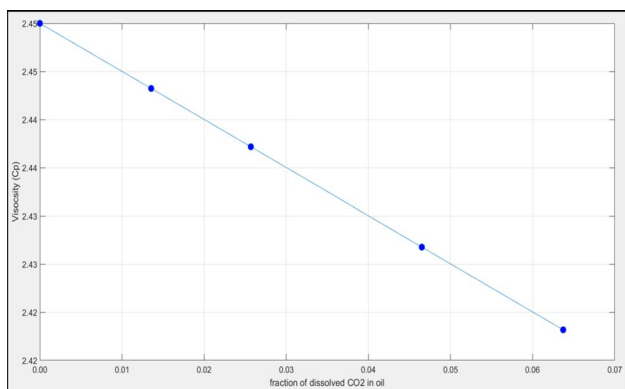

**Fig. 3** Effect of oil viscosity due to fraction of dissolved CO<sub>2</sub> and cumulative day of injection

In Fig. 3, we can see that as higher cumulative days of injection we got higher CO<sub>2</sub>, this happened due to the accumulation of CO<sub>2</sub> in the oil phase, for example at a pressure of 600 psig and the cumulative 300 days, we obtained an equilibrium of CO<sub>2</sub> fraction in oil (xCO<sub>2</sub>) as much as 0.01 until the cumulative 1800 days. Similarly, in other simulations we computed higher pressure and we got higher value of xCO<sub>2</sub>.

Then, the simulation is continued by entering parameters in the target field, and the target field parameter data can be seen in Tables 1 and 2. The simulation of the changes in oil viscosity due to CO<sub>2</sub> levels in oil is presented in Fig. 3; it shows that the greater the CO<sub>2</sub> content dissolved in oil will lower viscosity, and the longer duration of imbibition also affects the oil viscosity as shown in Fig. 4.

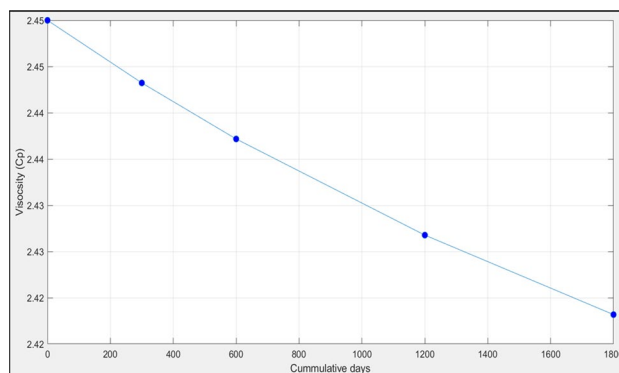

**Fig. 4** Effect of oil viscosity vs cumulative days of injection

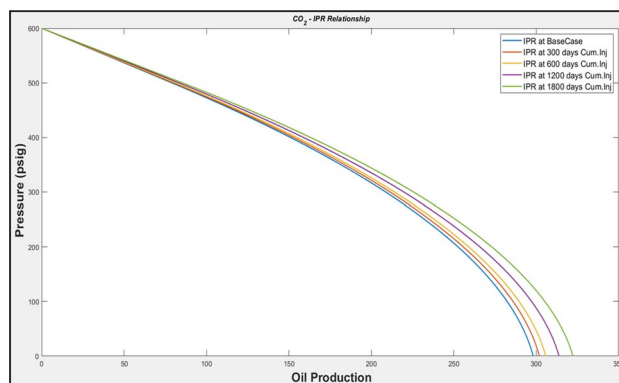

**Fig. 5** Graph of future inflow performance relationship (IPR)

**Table 3** Comparison of daily oil production within conventional method and CO<sub>2</sub> flood method

No	Daily oil prod (BOPD)		Cumulative days of injection	Gain (%)
	Without CO <sub>2</sub> flood	CO <sub>2</sub> flood method		
1	252	252	0	0.0
2	252	256	300	1.5
3	252	260	600	3.1
4	252	266	1200	6.7
5	252	273	1800	8.0

**Simulation of inflow performance relationship improvement and cumulative oil production due to CO<sub>2</sub> fraction in oil**

In this sub-section, we computed inflow performance relationship values at various viscosity values due to accumulation of dissolved CO<sub>2</sub> during injection process. In Fig. 5, it can be seen that the injection pressure at

600 psig gives an increase of IPR in every cumulative day of injection, which affects cumulative oil production (Eqs. 6 and 7). From Fig. 5 and Table 3, it shows that in the cumulative 300 days, CO<sub>2</sub> injection method takes the lead in cumulative oil production compared to conventional method.

### Estimated cost of CO<sub>2</sub> purification facilities

In this section we will discuss estimation cost of CO<sub>2</sub> purification, with baseline 31 MMSCFD of gas feed. By computing in commercial process simulation software we got results as presented in Table 4, we can see that the cost of equipment for the cryogenic distillation method is about \$ 9.5 million, with 86% purity of CO<sub>2</sub> gas product.

CO<sub>2</sub> purification facilities are available in two options: cryogenic distillation facilities and contactor amine facilities. Cryogenic distillation is recovering CO<sub>2</sub> by separating mixture based on boiling point differences, as shown in Fig. 6. Cryogenic distillation facilities consist of two compressors, two columns distillation and tank. Gas compressor is inflating gas pressure, gas flowing into demethanizer

contactor separating gas from light hydrocarbon mixture (mainly methane), top product is send to DHU and bottom product is flowing into CO<sub>2</sub>-column, top product (mainly CO<sub>2</sub>) is flowing into injection compressor, and bottom product or condensate product is sent to liquid tank. Contactor amine facilities are to recover CO<sub>2</sub> by absorbing CO<sub>2</sub> through DEA/MDEA, as shown in Fig. 7. Amine facilities have three main units for processing: compressor, DEA contactor, DEA recovery column. The compressor is used to increase the pressure, then the gas is flowing into DEA contactor to dehydrated hydrocarbon gas, the bottom product of DEA contactor is flow into DEA recovery column to clean up DEA, and thus, it can be recycled into DEA contactor. Total investment for facilities is available in three options: \$19.5 M for MDEA contactor, \$19 M for DEA contactor and \$9.5 M for cryogenic distillation as described in Table 4, whereas the process flow diagram (PFD) of purification facility can be seen in Figs. 6 and 7, respectively.

**Table 4** Simulation results of CO<sub>2</sub> gas purification by various methods

Feed rate (MMSCFD/day)	% mol CO <sub>2</sub> feed	Sweet gas (m <sup>3</sup> /day)	% CO <sub>2</sub> sweet gas	Rate of CO <sub>2</sub> product	% mol of CO <sub>2</sub> at CO <sub>2</sub> product	Investment cost (million USD)
Contactor MDEA						
31	29	19	5	12	68	19.5
Contactor DEA						
31	29	19	5	12	67	19
Cryogenic distillation						
31	29	20	3.5	20	86	9.5

**Fig. 6** PFD of cryogenic distillation facilities

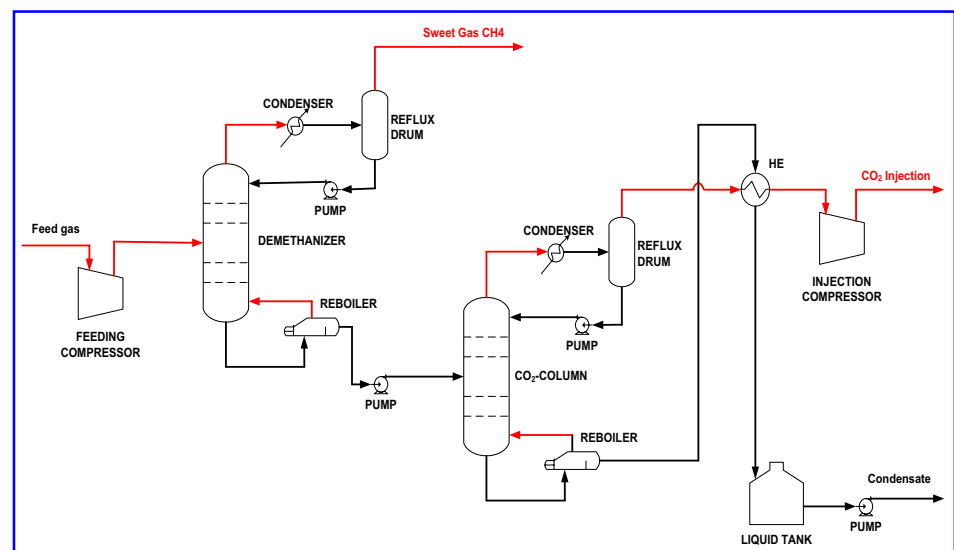

**Fig. 7** PFD of contactor amine facilities

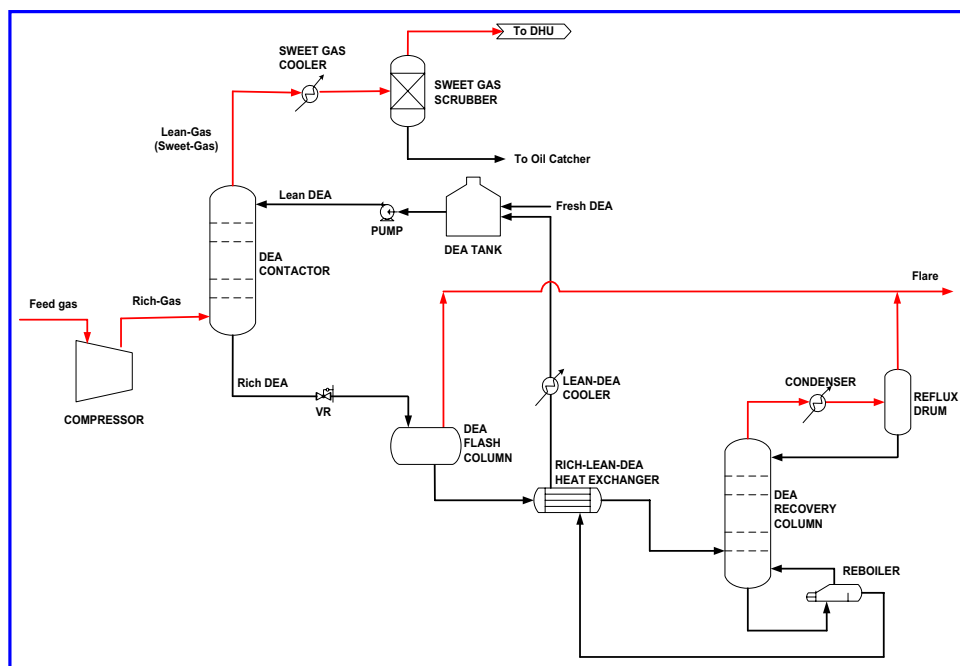

## Conclusion

Based on the results of the analysis and discussion above, it can be concluded as follows:

1. Evaluation of CO<sub>2</sub>-EOR feasibility can be obtained from integration of the following aspects:
  - a. GGRP data properties, maximum CO<sub>2</sub> dissolved and CO<sub>2</sub> injection rates can estimate oil recovery gain.
  - b. The needs of CO<sub>2</sub> supply and oil recovery gain will affect design of surface facilities.
  - c. Oil recovery gain and the need of surface facilities are used for economic consideration.
2. The integration of GGRP aspects is able to provide an overview of the feasibility evaluation of CO<sub>2</sub>-EOR, quickly, simply and integrated.
3. The simulation study conducted is very useful as a guide before starting the CO<sub>2</sub>-EOR study in more detail using reservoir models and EOS pressure volume temperature (PVT) regression analysis for CO<sub>2</sub>-hydrocarbons.

**Open Access** This article is licensed under a Creative Commons Attribution 4.0 International License, which permits use, sharing, adaptation, distribution and reproduction in any medium or format, as long as you give appropriate credit to the original author(s) and the source, provide a link to the Creative Commons licence, and indicate if changes were made. The images or other third party material in this article are included in the article's Creative Commons licence, unless indicated otherwise in a credit line to the material. If material is not included in the article's Creative Commons licence and your intended use is not permitted by statutory regulation or exceeds the permitted use, you will

need to obtain permission directly from the copyright holder. To view a copy of this licence, visit <http://creativecommons.org/licenses/by/4.0/>.

## References

- Abdassah D, Siregar S, Kristanto D (2000) The potential of carbon dioxide gas injection application in improving oil recovery. In: International oil and gas conference and exhibition in China. Society of Petroleum Engineers
- Abdurrahman M et al (2017) EOR in Indonesia: past, present, and future. *Int J Oil Gas Coal Technol* 16(3):250–270
- Barclay TH, Mishra S (2016) New correlations for CO<sub>2</sub>-oil solubility and viscosity reduction for light oils. *J Petrol Explor Prod Tech* 6(4):815–823
- Buckley SE, Leverett MC (1942) Mechanism of fluid displacement in sands. *Trans AIME* 146(01):107–116
- Chae K-S, Lee JW (2015) Risk analysis and simulation for geologic storage of CO<sub>2</sub>. In: Proceedings of the World congress on advances in civil, environmental, and materials research, Incheon, Korea
- Emera MK, Sarma HK (2006) A genetic algorithm-based model to predict co-oil physical properties for dead and live oil. In: Canadian international petroleum conference. Petroleum Society of Canada
- Gary JH, Handwerk GE, Kaiser M (1984) Refinery products. *Petroleum refining: technology and economics*, 2nd edn. Marcel Dekker Inc, New York, pp 5–15
- Holm LW, Josendal VA (1974) Mechanisms of oil displacement by carbon dioxide. *J Petrol Technol* 26(12):1–427
- Kohl AL, Richard N (1997) Gas purification. Gulf Professional Publishing, pp 87–132
- Leach MP, Yellig WF (1981) Compositional model studies-CO<sub>2</sub> oil-displacement mechanisms. *Soc Petrol Eng J* 21(01):89–97



- Lee YL et al (2015) Overview of CO<sub>2</sub>-EOR operation plan in Meruap field. In: Proceedings of the World congress on advances in civil, environmental, and materials research, Incheon, Korea
- LPPM UPN “Veteran” Yogyakarta (2011) Feasibility study of CO<sub>2</sub> flooding. Lapangan Jatibarang, Pertamina EP Region Jawa, Yogyakarta
- Miller JS, Jones RA (1981) A laboratory study to determine physical characteristics of heavy oil after CO<sub>2</sub> saturation. SPE/DOE Enhanced Oil Recovery Symposium, Society of Petroleum Engineers
- Miller LN, Macriss RA, Zawacki TS (1978) Process for acid gas removal from gaseous mixtures. No. US 4080424
- Ministry of Energy and Mineral Resources of Republic of Indonesia (MEMRRI) (2017) Handbook of energy and economic statistics of Indonesia 2017. Pusdatin ESDM, Jakarta
- Muslim A et al (2013) Opportunities and challenges of CO<sub>2</sub> flooding implementation in Indonesia. In: SPE Asia Pacific oil and gas conference and exhibition
- Rostami A et al (2017) Modeling of CO<sub>2</sub> solubility in crude oil during carbon dioxide enhanced oil recovery using gene expression programming. Fuel 210:768–782
- Satuan Kerja Khusus Pelaksana Kegiatan Usaha Hulu Minyak dan Gas Bumi (SKK Migas) (2016), Laporan Tahunan 2016, Jakarta, Indonesia
- Sohrabi M, Emadi A (2012), Novel insights into the pore-scale mechanisms of enhanced oil recovery by CO<sub>2</sub> injection. In: SPE Europe/EAGE annual conference. Society of Petroleum Engineers
- Suarsana IP (2010) Producing high CO<sub>2</sub> gas content reservoirs in Pertamina Indonesia using multi stage cryogenic process. In: SPE Asia Pacific oil and gas conference and exhibition. Society of Petroleum Engineers
- Yellig WF (1982) Carbon dioxide displacement of a West Texas reservoir oil. Soc Petrol Eng J 22(06):805–815

**Publisher's Note** Springer Nature remains neutral with regard to jurisdictional claims in published maps and institutional affiliations.